

Sun StorEdge™ A3500/A3500FC Hardware Configuration Guide



THE NETWORK IS THE COMPUTER™

Sun Microsystems, Inc.
901 San Antonio Road
Palo Alto, CA 94303-4900 USA
650 960-1300 Fax 650 969-9131

Part No. 805-4981-13
December 1999, Revision A

Send comments about this document to: docfeedback@sun.com

Copyright 1999 Sun Microsystems, Inc., 901 San Antonio Road • Palo Alto, CA 94303-4900 USA. All rights reserved.

This product or document is protected by copyright and distributed under licenses restricting its use, copying, distribution, and decompilation. No part of this product or document may be reproduced in any form by any means without prior written authorization of Sun and its licensors, if any. Third-party software, including font technology, is copyrighted and licensed from Sun suppliers.

Parts of the product may be derived from Berkeley BSD systems, licensed from the University of California. UNIX is a registered trademark in the U.S. and other countries, exclusively licensed through X/Open Company, Ltd. For Netscape Communicator™, the following notice applies: Copyright 1995 Netscape Communications Corporation. All rights reserved.

Sun, Sun Microsystems, the Sun logo, AnswerBook, docs.sun.com, Solaris, StorEdge, Ultra, Ultra Enterprise, and RSM are trademarks, registered trademarks, or service marks of Sun Microsystems, Inc. in the U.S. and other countries. All SPARC trademarks are used under license and are trademarks or registered trademarks of SPARC International, Inc. in the U.S. and other countries. Products bearing SPARC trademarks are based upon an architecture developed by Sun Microsystems, Inc.

The OPEN LOOK and Sun™ Graphical User Interface was developed by Sun Microsystems, Inc. for its users and licensees. Sun acknowledges the pioneering efforts of Xerox in researching and developing the concept of visual or graphical user interfaces for the computer industry. Sun holds a non-exclusive license from Xerox to the Xerox Graphical User Interface, which license also covers Sun's licensees who implement OPEN LOOK GUIs and otherwise comply with Sun's written license agreements.

RESTRICTED RIGHTS: Use, duplication, or disclosure by the U.S. Government is subject to restrictions of FAR 52.227-14(g)(2)(6/87) and FAR 52.227-19(6/87), or DFAR 252.227-7015(b)(6/95) and DFAR 227.7202-3(a).

DOCUMENTATION IS PROVIDED "AS IS" AND ALL EXPRESS OR IMPLIED CONDITIONS, REPRESENTATIONS AND WARRANTIES, INCLUDING ANY IMPLIED WARRANTY OF MERCHANTABILITY, FITNESS FOR A PARTICULAR PURPOSE OR NON-INFRINGEMENT, ARE DISCLAIMED, EXCEPT TO THE EXTENT THAT SUCH DISCLAIMERS ARE HELD TO BE LEGALLY INVALID.

Copyright 1999 Sun Microsystems, Inc., 901 San Antonio Road • Palo Alto, CA 94303-4900 Etats-Unis. Tous droits réservés.

Ce produit ou document est protégé par un copyright et distribué avec des licences qui en restreignent l'utilisation, la copie, la distribution, et la décompilation. Aucune partie de ce produit ou document ne peut être reproduite sous aucune forme, par quelque moyen que ce soit, sans l'autorisation préalable et écrite de Sun et de ses bailleurs de licence, s'il y en a. Le logiciel détenu par des tiers, et qui comprend la technologie relative aux polices de caractères, est protégé par un copyright et licencié par des fournisseurs de Sun.

Des parties de ce produit pourront être dérivées des systèmes Berkeley BSD licenciés par l'Université de Californie. UNIX est une marque déposée aux Etats-Unis et dans d'autres pays et licenciée exclusivement par X/Open Company, Ltd. La notice suivante est applicable à Netscape Communicator™ : Copyright 1995 Netscape Communications Corporation. All rights reserved.

Sun, Sun Microsystems, the Sun logo, AnswerBook2, docs.sun.com, Solaris, StorEdge, Ultra, Ultra Enterprise, et RSM sont des marques de fabrique ou des marques déposées, ou marques de service, de Sun Microsystems, Inc. aux Etats-Unis et dans d'autres pays. Toutes les marques SPARC sont utilisées sous licence et sont des marques de fabrique ou des marques déposées de SPARC International, Inc. aux Etats-Unis et dans d'autres pays. Les produits portant les marques SPARC sont basés sur une architecture développée par Sun Microsystems, Inc.

L'interface d'utilisation graphique OPEN LOOK et Sun™ a été développée par Sun Microsystems, Inc. pour ses utilisateurs et licenciés. Sun reconnaît les efforts de pionniers de Xerox pour la recherche et le développement du concept des interfaces d'utilisation visuelle ou graphique pour l'industrie de l'informatique. Sun détient une licence non exclusive de Xerox sur l'interface d'utilisation graphique Xerox, cette licence couvrant également les licenciés de Sun qui mettent en place l'interface d'utilisation graphique OPEN LOOK et qui en outre se conforment aux licences écrites de Sun.

CETTE PUBLICATION EST FOURNIE "EN L'ETAT" ET AUCUNE GARANTIE, EXPRESSE OU IMPLICITE, N'EST ACCORDEE, Y COMPRIS DES GARANTIES CONCERNANT LA VALEUR MARCHANDE, L'APTITUDE DE LA PUBLICATION A REPOUDRE A UNE UTILISATION PARTICULIERE, OU LE FAIT QU'ELLE NE SOIT PAS CONTREFAISANTE DE PRODUIT DE TIERS. CE DENI DE GARANTIE NE S'APPLIQUERAIT PAS, DANS LA MESURE OU IL SERAIT TENU JURIDIQUEMENT NUL ET NON AVENU.



Contents

Preface vii

1. SCSI Host Connections 1-1

- 1.1 Configuration Guidelines 1-2
- 1.2 Supported SCSI Host Configurations 1-3
 - 1.2.1 Single Host Connected to One Controller Module 1-3
 - 1.2.2 Two Controller Modules Daisy-Chained to One Host 1-4
 - 1.2.3 Independent Controller Module Connected to Two Hosts 1-5
 - 1.2.4 Multi-Host 1-6
- 1.3 Ultra 2 Host System Power Connection Requirement 1-7

2. FC-AL Host Connections 2-1

- 2.1 Configuration Guidelines 2-2
- 2.2 Supported FC-AL Host Configurations 2-3
 - 2.2.1 Single Host Connected to One Controller Module 2-4
 - 2.2.2 Independent Controller Module Connected to Two Hosts 2-5
 - 2.2.3 Single Host Connected to One Controller Module Using Hubs 2-6
 - 2.2.4 Single Host Connected to Two Controller Modules Using Hubs 2-7

- 2.2.5 Single Host Connected to Four Controller Modules in a Loop Using Hubs 2-9
- 2.2.6 Multi-Host 2-11
- 2.3 Setting the Loop ID 2-13

3. Sun StorEdge A3500/A3500FC Configurations 3-1

- 3.1 StorEdge D1000 Disk Array Settings 3-2
 - 3.1.1 1x2 Configuration 3-3
 - 3.1.1.1 Option Switch 3-3
 - 3.1.1.2 Module ID Switch 3-4
 - 3.1.1.3 SCSI Jumper Cables and Terminators 3-4
 - 3.1.2 1x5 Configuration 3-5
 - 3.1.2.1 Option Switch 3-5
 - 3.1.2.2 Module ID Switch 3-6
 - 3.1.2.3 SCSI Jumper Cables and Terminators 3-6
 - 3.1.3 2x7 Configuration 3-7
 - 3.1.3.1 Option Switch 3-7
 - 3.1.3.2 Module ID Switch 3-8
 - 3.1.3.3 SCSI Jumper Cables and Terminators 3-8
 - 3.1.4 3x15 Configuration 3-9
 - 3.1.4.1 Option Switch 3-9
 - 3.1.4.2 Module ID Switch 3-9
 - 3.1.4.3 SCSI Jumper Cables and Terminators 3-10
- 3.2 1x2 Cables and Connections 3-11
 - 3.2.1 Driveside SCSI Connections 3-11
 - 3.2.2 Power Connections 3-13
- 3.3 1x5 Cables and Connections 3-14
 - 3.3.1 Driveside SCSI Connections 3-14
 - 3.3.2 Power Connections 3-16

3.4	2x7 Cables and Connections	3-17
3.4.1	SCSI Cable Lengths	3-17
3.4.2	Power Connections	3-19
3.5	3x15 Cables and Connections	3-20
3.5.1	SCSI Cable Lengths	3-20
3.5.2	Connections Between Power Sequencers	3-25
3.5.3	Connections to AC Power Sources	3-25
3.5.4	Power Connections for Expansion Cabinets	3-26
A.	Sun StorEdge A3500 and A3500FC Specifications	A-1
A.1	Initial Cold Start Surge Current Specifications	A-1

Preface

The *Sun StorEdge A3500/A3500FC Hardware Configuration Guide* provides configuration instructions for the Sun StorEdge™ A3500/A3500FC systems. These instructions are designed for an experienced system administrator.

How This Book Is Organized

Chapter 1 describes configurations for one or two small computer system interface (SCSI) StorEdge A3500 controller modules connected to one or more hosts. It also contains information about connecting power to a Sun Ultra™ host system.

Chapter 2 describes configurations for one or two Fibre Channel-Arbitrated Loop (FC-AL) StorEdge A3500FC controller modules connected to one or more hosts.

Chapter 3 explains how to set up the configurations supported by Sun. It also includes information about StorEdge D1000 disk array settings and cables and connections for each configuration.

Appendix A contains specifications for the StorEdge A3500/A3500FC systems.

Using UNIX Commands

This document does not contain information on basic UNIX® commands and procedures such as shutting down the system, booting the system, and configuring devices.

See one or more of the following for this information:

- *Solaris Handbook for Sun Peripherals*
- AnswerBook™ online documentation for the Solaris™ software environment
- Other software documentation that you received with your system

Typographic Conventions

TABLE P-1 Typographic Conventions

Typeface or Symbol	Meaning	Examples
AaBbCc123	The names of commands, files, and directories; on-screen computer output.	Edit your <code>.login</code> file. Use <code>ls -a</code> to list all files. % You have mail.
AaBbCc123	What you type, when contrasted with on-screen computer output.	% su Password:
<i>AaBbCc123</i>	Book titles, new words or terms, words to be emphasized. Command-line variable; replace with a real name or value.	Read Chapter 6 in the <i>User's Guide</i> . These are called <i>class</i> options. You <i>must</i> be <i>root</i> to do this. To delete a file, type <code>rm filename</code> .

Shell Prompts

TABLE P-2 Shell Prompts

Shell	Prompt
C shell	<i>machine_name</i> %
C shell superuser	<i>machine_name</i> #
Bourne shell and Korn shell	\$
Bourne shell and Korn shell superuser	#

Related Documentation

TABLE P-3 Related Documentation

Title	Part Number
<i>Sun StorEdge A3500/A3500FC Controller Module Guide</i>	805-4980
<i>Sun StorEdge A3500/A3500FC Task Map</i>	805-4982
<i>Sun StorEdge Expansion Cabinet Installation and Service Manual</i>	805-3067
<i>Sun StorEdge RAID Manager Controller Replacement Guide</i>	805-7854
<i>Sun StorEdge A3500FC Controller Upgrade Guide</i>	806-0479
<i>Sun StorEdge RAID Manager 6.22 Release Notes</i>	805-7758
<i>Sun StorEdge RAID Manager 6.22 Installation and Support Guide for Solaris</i>	805-7756
<i>Sun StorEdge RAID Manager 6.22 User's Guide</i>	806-0478
<i>Sun StorEdge RAID Manager 6.1.1 Update 2 Release Notes</i>	805-3656
<i>Sun StorEdge RAID Manager 6.1.1 Installation and Support Guide for Solaris</i>	805-4058
<i>Sun StorEdge RAID Manager 6.1.1 User's Guide</i>	805-4057
<i>Sun StorEdge RAID Manager 6.2.21 Release Notes for Microsoft Windows NT</i>	805-6890
<i>Sun StorEdge RAID Manager 6.2 Installation and Support Guide for Microsoft Windows NT</i>	805-6888
<i>Sun StorEdge RAID Manager 6.2 User's Guide</i>	805-6887

Sun Documentation on the Web

The `docs.sun.comsm` web site enables you to access Sun technical documentation on the Web. You can browse the `docs.sun.com` archive or search for a specific book title or subject at:

`http://docs.sun.com`

Sun Welcomes Your Comments

We are interested in improving our documentation and welcome your comments and suggestions. You can email your comments to us at:

`docfeedback@sun.com`

Please include the part number of your document in the subject line of your email.

SCSI Host Connections

This chapter describes configurations for one or two small computer system interface (SCSI) Sun StorEdge A3500 controller modules connected to one or more hosts. It also contains information about connecting power to a Sun Ultra™ host system.

The topics covered in this chapter are:

- Configuration Guidelines—page 1-2
- Supported SCSI Host Configurations—page 1-3
 - Single Host Connected to One Controller Module—page 1-3
 - Two Controller Modules Daisy-Chained to One Host—page 1-4
 - Independent Controller Module Connected to Two Hosts—page 1-5
 - Multi-Host—page 1-6
- Ultra 2 Host System Power Connection Requirement—page 1-7

Note – The RAID Manager 6.22 software does not support Ultra 2 host systems.

1.1 Configuration Guidelines

Use the following guidelines to install and cable or reconfigure your StorEdge A3500 system.

- The part number for the 12 meter SCSI host cable is 530-1886-xx.
- Do not exceed a SCSI bus length of 25 meters (82 feet).
- Make sure that the last StorEdge A3500 controller module in any daisy chain has a total of two terminators—one in each SCSI OUT port.
- If you are adding a controller module to an already existing configuration, halt all activity on the SCSI bus before removing any SCSI cables.
- Once you finish cabling the devices and powering on, reboot the system by typing `boot -r` at the `ok` prompt before beginning any SCSI bus activity.
- Perform a system check to make sure that SCSI connections are secure. Look for fault LEDs on the hardware or error messages in the RAID Manager GUI.

Note – Refer to your server and rack documentation for instructions on grounding the StorEdge A3500 expansion cabinet.

1.2 Supported SCSI Host Configurations

The illustrations in this section show the SCSI cable connections for the configurations that are supported by Sun.

- Single Host Connected to One Controller Module
- Two Controller Modules Daisy-Chained to One Host
- Independent Controller Module Connected to Two Hosts
- Multi-Host

1.2.1 Single Host Connected to One Controller Module

FIGURE 1-1 shows one host connected with SCSI cables to one StorEdge A3500 controller module.

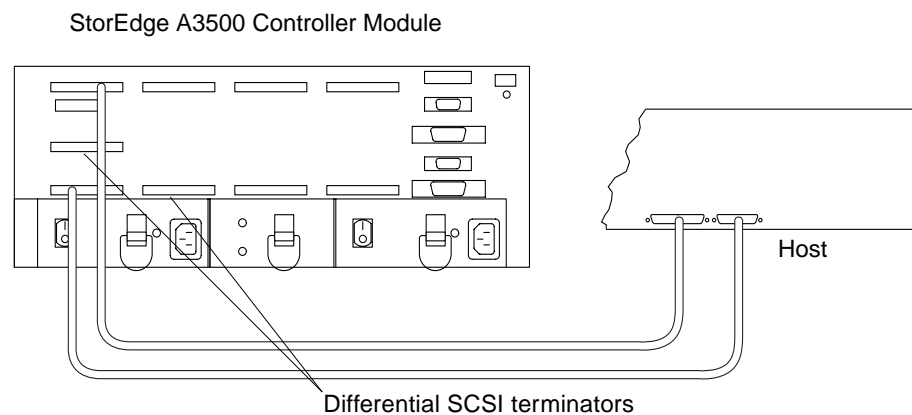

FIGURE 1-1 One Host Connected to One Controller Module

1.2.2 Two Controller Modules Daisy-Chained to One Host

FIGURE 1-2 shows two StorEdge A3500 controller modules daisy-chained with SCSI cables to one host. You can daisy-chain controller modules in the same or separate cabinets.

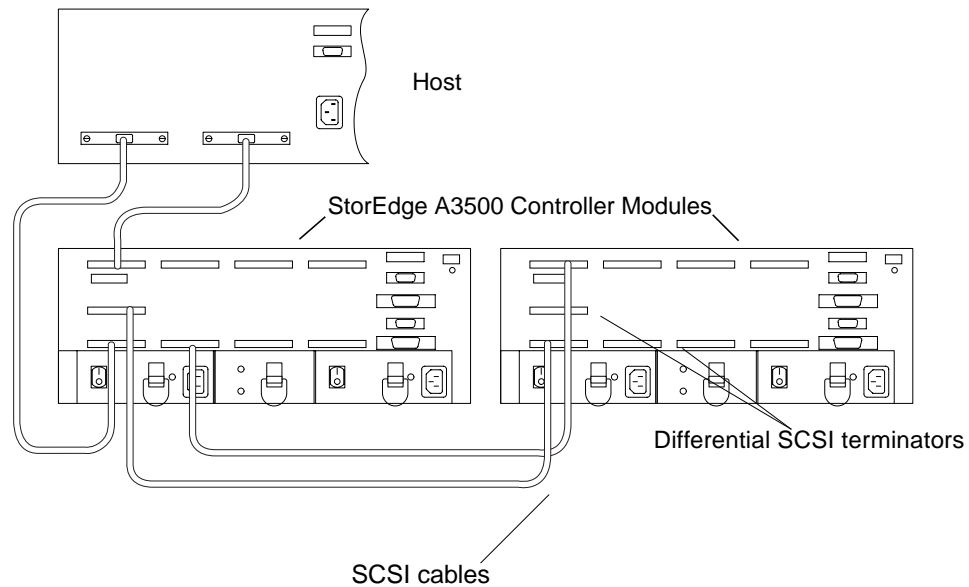

FIGURE 1-2 Two Controller Modules Daisy-Chained to One Host

Note – The SCSI cables between the two controller modules are crossed to prevent the SCSI IDs for the controllers from conflicting.

1.2.3 Independent Controller Module Connected to Two Hosts

FIGURE 1-3 shows one StorEdge A3500 controller module connected with SCSI cables to two hosts.

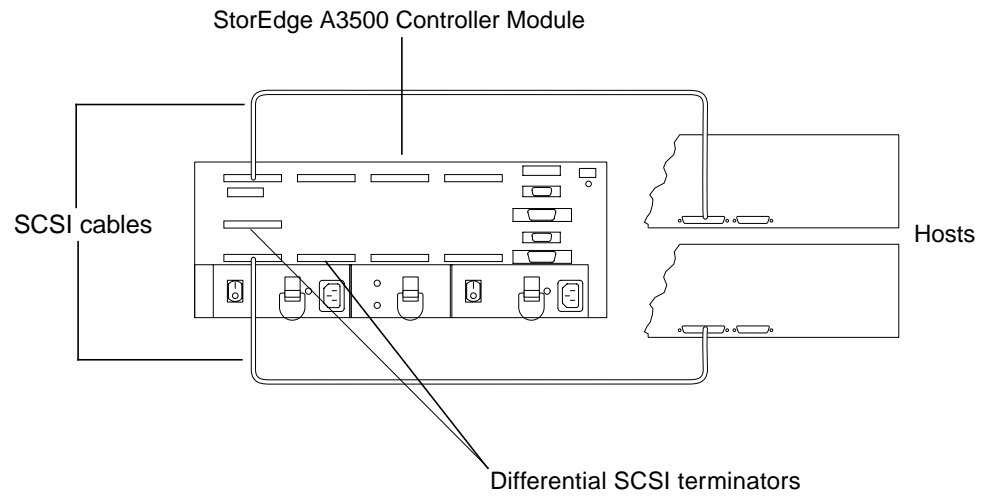

FIGURE 1-3 Independent Controller Module Connected to Two Hosts

1.2.4 Multi-Host

FIGURE 1-4 shows a two-node multi-host configuration: one StorEdge A3500 controller module connected with SCSI cables to two hosts.

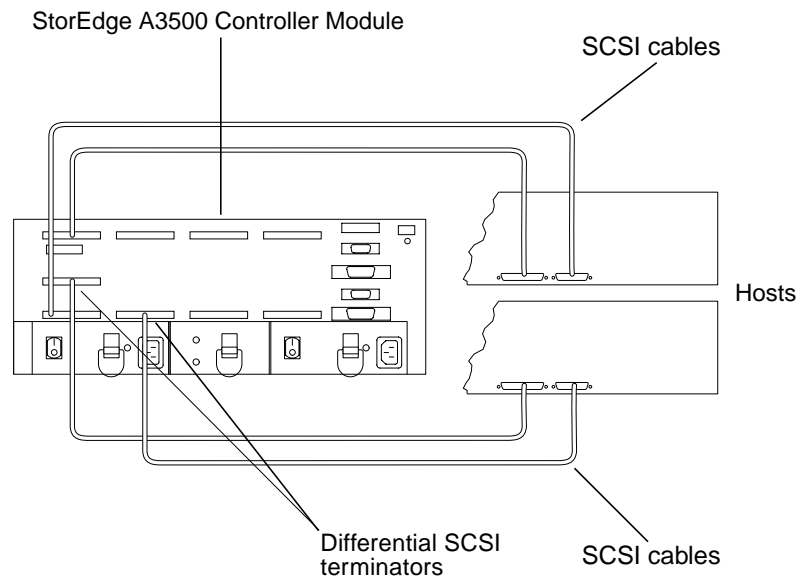

FIGURE 1-4 Two-Node Multi-Host Configuration

Note – The configuration shown in FIGURE 1-4 requires cluster software for management.

For more information regarding the two-node multi-host configuration, such as instructions for setting host SCSI IDs, refer to the Sun™ Cluster documentation that is shipped with the host system.

For information about StorEdge A3500/A3500FC support for multi-host configurations, refer to “Frequently Asked Questions” (FAQ) in the *Sun StorEdge RAID Manager 6.1.1 Release Notes* (805-3656-xx) and in the *Sun StorEdge RAID Manager 6.2.2 Release Notes* (805-7758-xx) and to the *Sun StorEdge RAID Manager User’s Guide*.

1.3 Ultra 2 Host System Power Connection Requirement

You can connect a controller module to an Ultra 2 host system; however, you must connect the power cord of the Ultra 2 host to one of the AC power sequencers in the expansion cabinet that contains the controller module.

Note – The RAID Manager 6.22 software does not support Ultra 2 host systems.

You need to order one of the following power cords depending on the type of power sequencer in the expansion cabinet (FIGURE 1-5):

- Ultra Enterprise™ expansion cabinet and StorEdge expansion cabinet—part number 530-2197
- 1422 mm/56-inch Data Center expansion cabinet—part number 180-1189 (United States) or 180-1190 NEMA (European)



Caution – Failure to connect the power cord correctly as described here may cause excessive ground current that could damage the system.

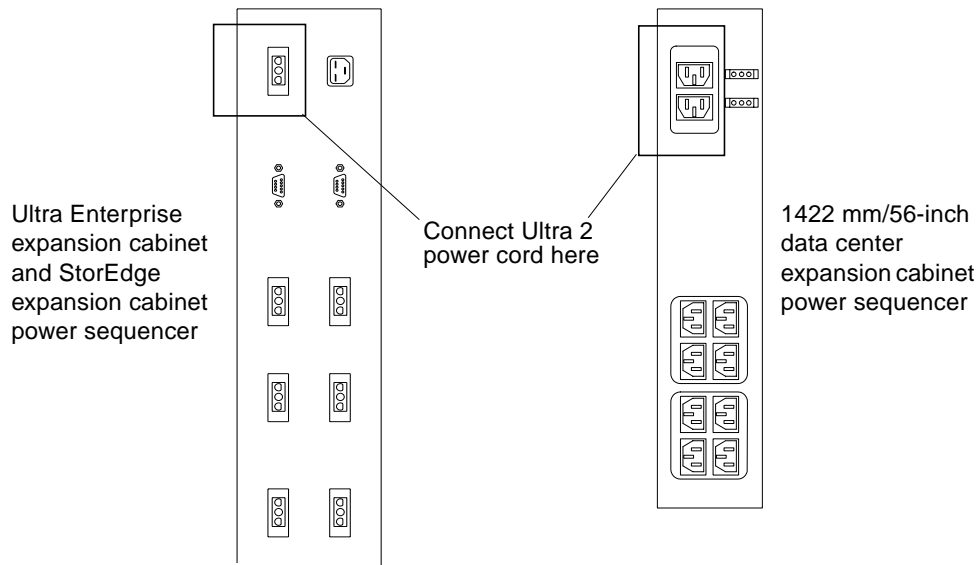

FIGURE 1-5 AC Power Sequencers—Ultra 2 Power Connector

To connect the power cord:

- 1. Gain access to the AC power sequencers.**
See the documentation that came with the expansion cabinet.
- 2. Route the power cable from the Ultra 2 host under the expansion cabinet frame on the same side as the power sequencer.**
- 3. Connect the power cord from the Ultra 2 host into the top power connector of either power sequencer (FIGURE 1-5).**

The power connectors are located on the other side of the power sequencer from the main switch.

- 4. Reassemble the expansion cabinet.**
See the documentation that you received with the expansion cabinet.

FC-AL Host Connections

This chapter describes configurations for one or two Fibre Channel-Arbitrated Loop (FC-AL) Sun StorEdge A3500FC controller modules connected to one or more hosts.

The following topics are covered in this chapter:

- Configuration Guidelines—page 2-2
- Supported FC-AL Host Configurations—page 2-3
 - Single Host Connected to One Controller Module—page 2-4
 - Independent Controller Module Connected to Two Hosts—page 2-5
 - Single Host Connected to One Controller Module Using Hubs—page 2-6
 - Single Host Connected to Two Controller Modules Using Hubs—page 2-7
 - Single Host Connected to Four Controller Modules in a Loop Using Hubs—page 2-9
 - Multi-Host—page 2-11
- Setting the Loop ID—page 2-13

2.1 Configuration Guidelines

Use the following guidelines to install and cable or reconfigure your StorEdge A3500FC system.



Caution – The onboard SOC+ on the I/O board is not qualified yet to work with the StorEdge A3500FC controller module.



Caution – At this time, only single port connection is qualified on the dual-ported host bus adapter card.

- The part number for the 15 meter FC-AL host cable is 595-3379-xx; the Marketing part number is X978A.
- Do not exceed a fiber-optic cable length of 500 meters (1640.5 feet).
- Install 16-bit, differential terminators to both HOST IN connectors on the back of the controller module (FIGURE 2-1).

Differential SCSI terminators—HOST IN

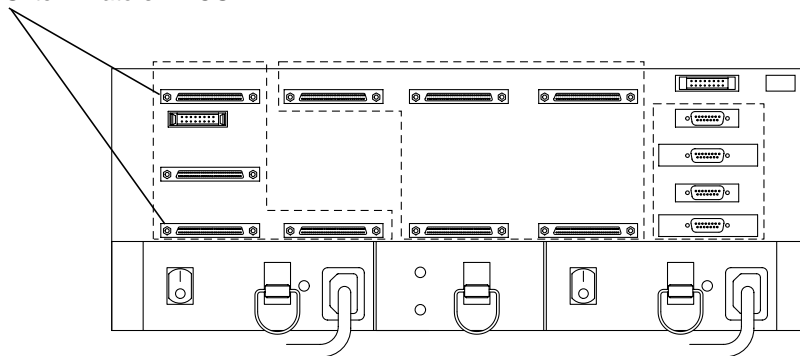

FIGURE 2-1 Differential SCSI Terminators on Rear of Controller Module

- Once you finish cabling the devices and powering on, reboot the system by typing `boot -r` at the `ok` prompt before beginning any SCSI bus activity.
- Perform a system check to make sure that SCSI and fiber-optic cable connections are secure. Check for fault LEDs on the hardware or error messages in the RAID Manager GUI.

Note – Refer to your server and rack documentation for instructions on grounding the StorEdge A3500FC expansion cabinet.

2.2 Supported FC-AL Host Configurations

The illustrations in this section show the FC-AL cable connections for the following configurations:

- Single Host Connected to One Controller Module
- Independent Controller Module Connected to Two Hosts
- Single Host Connected to One Controller Module Using Hubs
- Single Host Connected to Two Controller Modules Using Hubs
- Single Host Connected to Four Controller Modules in a Loop Using Hubs
- Multi-Host

2.2.1 Single Host Connected to One Controller Module

FIGURE 2-2 shows one host directly connected through fiber-optic cables to one StorEdge A3500FC controller module.

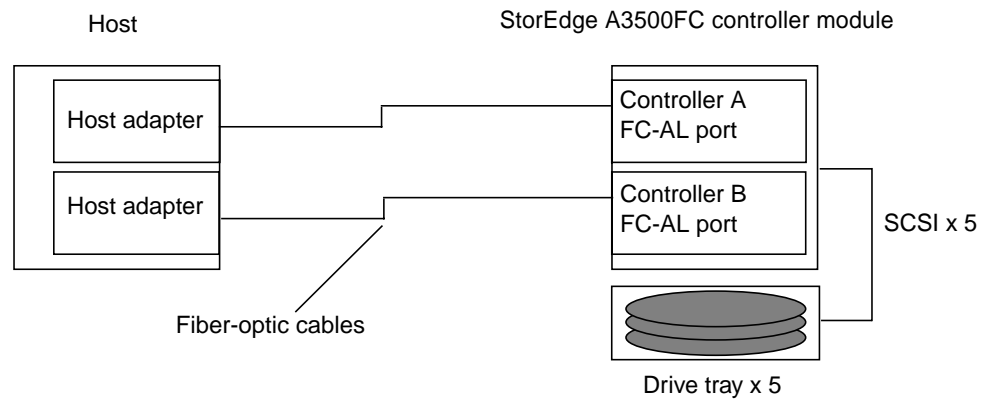

FIGURE 2-2 One Host Connected to One Controller Module

2.2.2 Independent Controller Module Connected to Two Hosts

FIGURE 2-3 shows one StorEdge A3500FC controller module connected through fibre-optic cables to two hosts. Refer to the *Sun StorEdge RAID Manager Installation and Support Guide* for instructions on setting up independent controller configurations in the RAID Manager software.

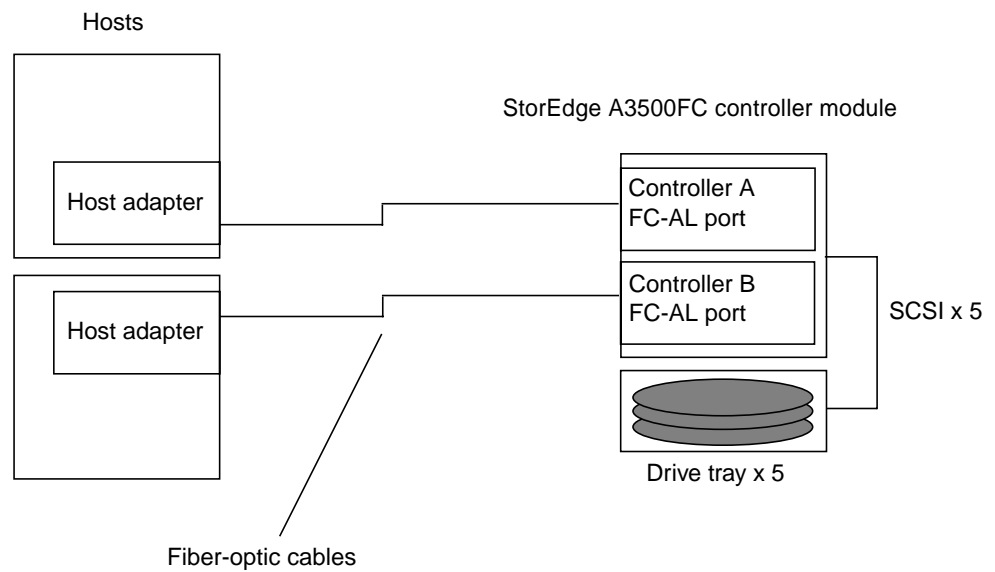

FIGURE 2-3 Independent Controller Module Connected to Two Hosts

2.2.3 Single Host Connected to One Controller Module Using Hubs

FIGURE 2-4 shows one host connected through fiber-optic cables to one StorEdge A3500FC controller module using hubs.

Note – No other type of fibre channel device should share the same loop or hub connected to the A3500FC controller module.

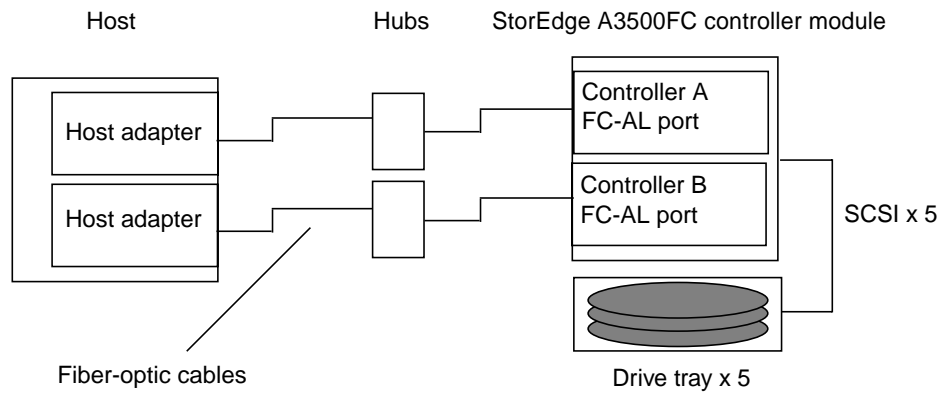

FIGURE 2-4 Single Host Connected to One Controller Module Using Hubs

2.2.4 Single Host Connected to Two Controller Modules Using Hubs

FIGURE 2-5 shows one host connected through fiber-optic cables to two StorEdge A3500FC controller modules using hubs. You can connect controller modules in the same or separate cabinets.

Note – No other type of fibre channel device should share the same loop or hub connected to the A3500FC controller module.

Each controller that is connected to a hub must have a unique loop ID. Whenever you add a second controller to a hub, make sure that the loop ID of the controller being connected is different from the loop ID of any other controller currently connected to the same hub.

Refer to Section 2.3 “Setting the Loop ID” on page 2-13 for instructions on setting the loop ID of a controller.



Caution – Ensure that the controller module IDs are set so that each hub is connected to A and B controller canisters.

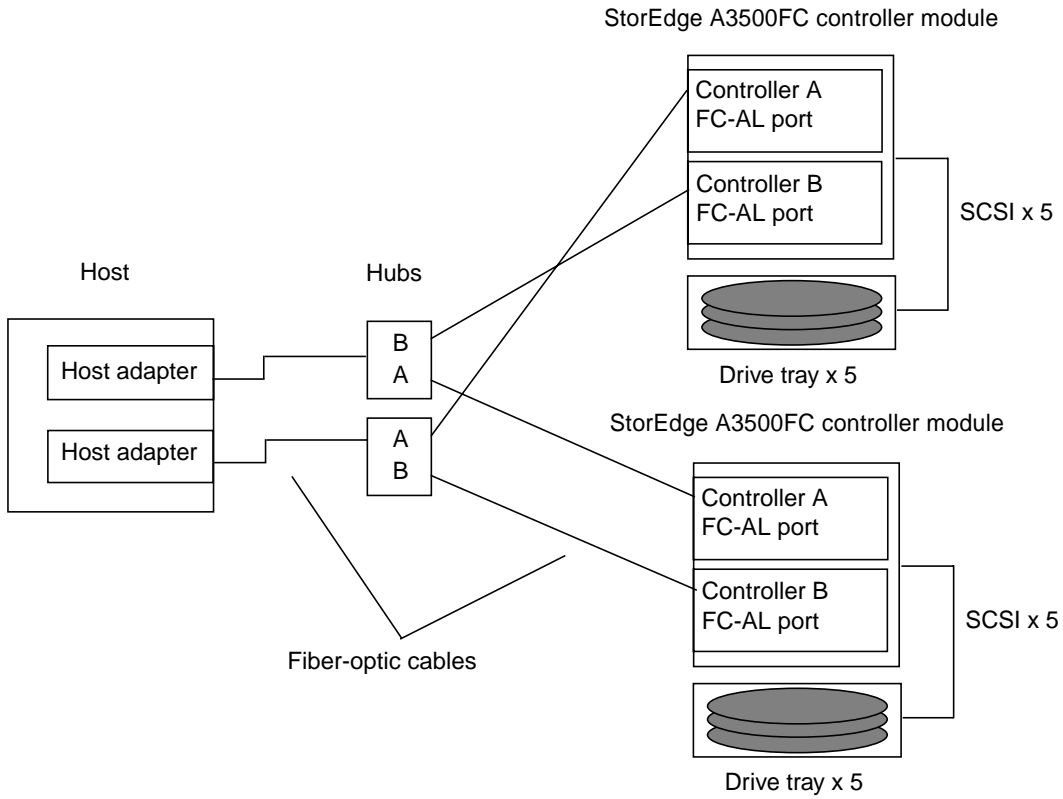

FIGURE 2-5 Single Host Connected to Two Controller Modules Using Hubs

2.2.5 Single Host Connected to Four Controller Modules in a Loop Using Hubs

FIGURE 2-6 shows an example of one host connected through fiber-optic cables to four StorEdge A3500FC controller modules in a loop using hubs.

Note – No other type of fibre channel device should share the same loop or hub connected to the A3500FC controller module.

Each controller that is connected to a hub must have a unique loop ID. Whenever you add a second controller to a hub, make sure that the loop ID of the controller being connected is different from the loop ID of any other controller currently connected to the same hub.

Refer to Section 2.3 “Setting the Loop ID” on page 2-13 for instructions on setting the loop ID of a controller.



Caution – Ensure that the controller module IDs are set so that each hub is connected to A and B controller canisters.

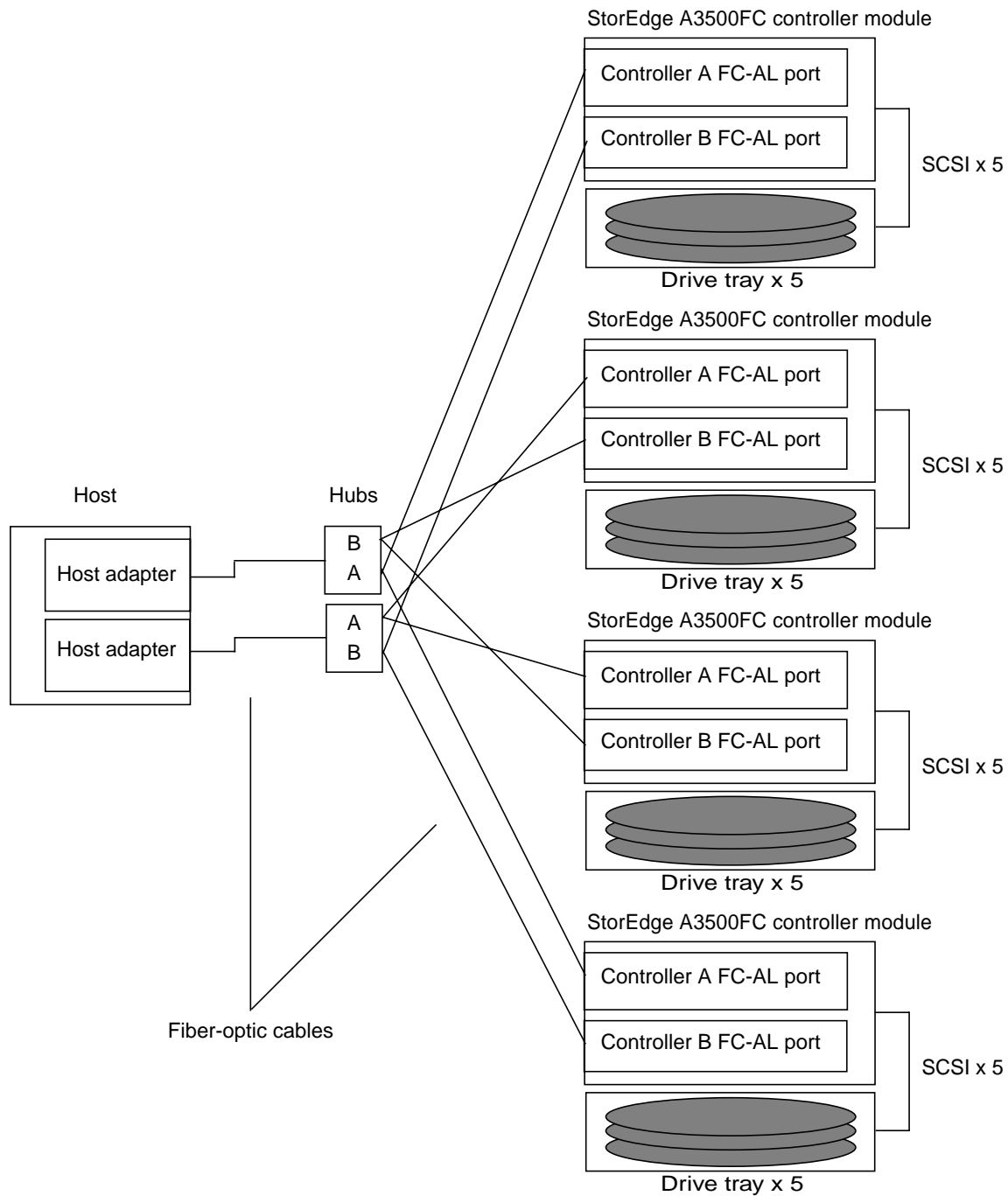

FIGURE 2-6 Single Host Connected to Four Controller Modules in a Loop Using Hubs

2.2.6 Multi-Host

FIGURE 2-7 shows an example of a multi-host configuration: two hosts connected through fiber-optic cables to two StorEdge A3500FC controller modules using hubs.

Note – No other type of fibre channel device should share the same loop or hub connected to the A3500FC controller module.

Each controller that is connected to a hub must have a unique loop ID. Whenever you add a second controller to a hub, make sure that the loop ID of the controller being connected is different from the loop ID of any other controller currently connected to the same hub.

Refer to Section 2.3 “Setting the Loop ID” on page 2-13 for instructions on setting the loop ID of a controller.



Caution – Ensure that the controller module IDs are set so that each hub is connected to A and B controller canisters.

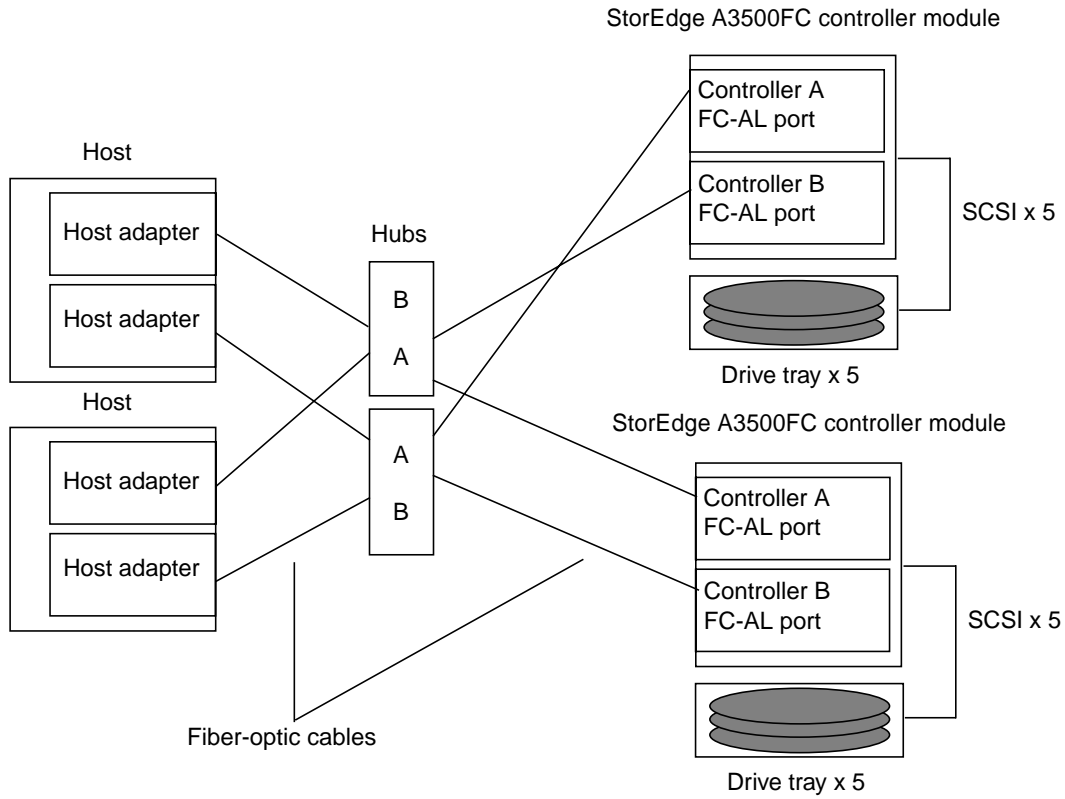

FIGURE 2-7 Two Hosts Connected to Two Controller Modules Using Hubs

2.3 Setting the Loop ID

This section explains how to set the loop ID of a controller that is connected to a hub.

Tools and equipment needed:

- Needlenose pliers
- Jumpers (supplied with the StorEdge A3500/A3500FC unit)
- Antistatic wrist strap

Every device attached to a SCSI or FC-AL bus must have a unique controller module ID number in order to communicate. The factory default ID settings for controller A and B are ID 5 and ID 4, respectively.

Note – Do not configure more than four controller modules on the same loop.

- 1. Locate the 16 pins on the rear of the FC-AL controller module (FIGURE 2-8).**

The eight pins on the right determine the host ID for controller 1(A); the pins on the left determine the ID for controller 2(B).
- 2. Wearing the antistatic wrist strap, install jumpers on the pins as shown in FIGURE 2-8.**

If necessary, use the needlenose pliers to remove the jumpers.

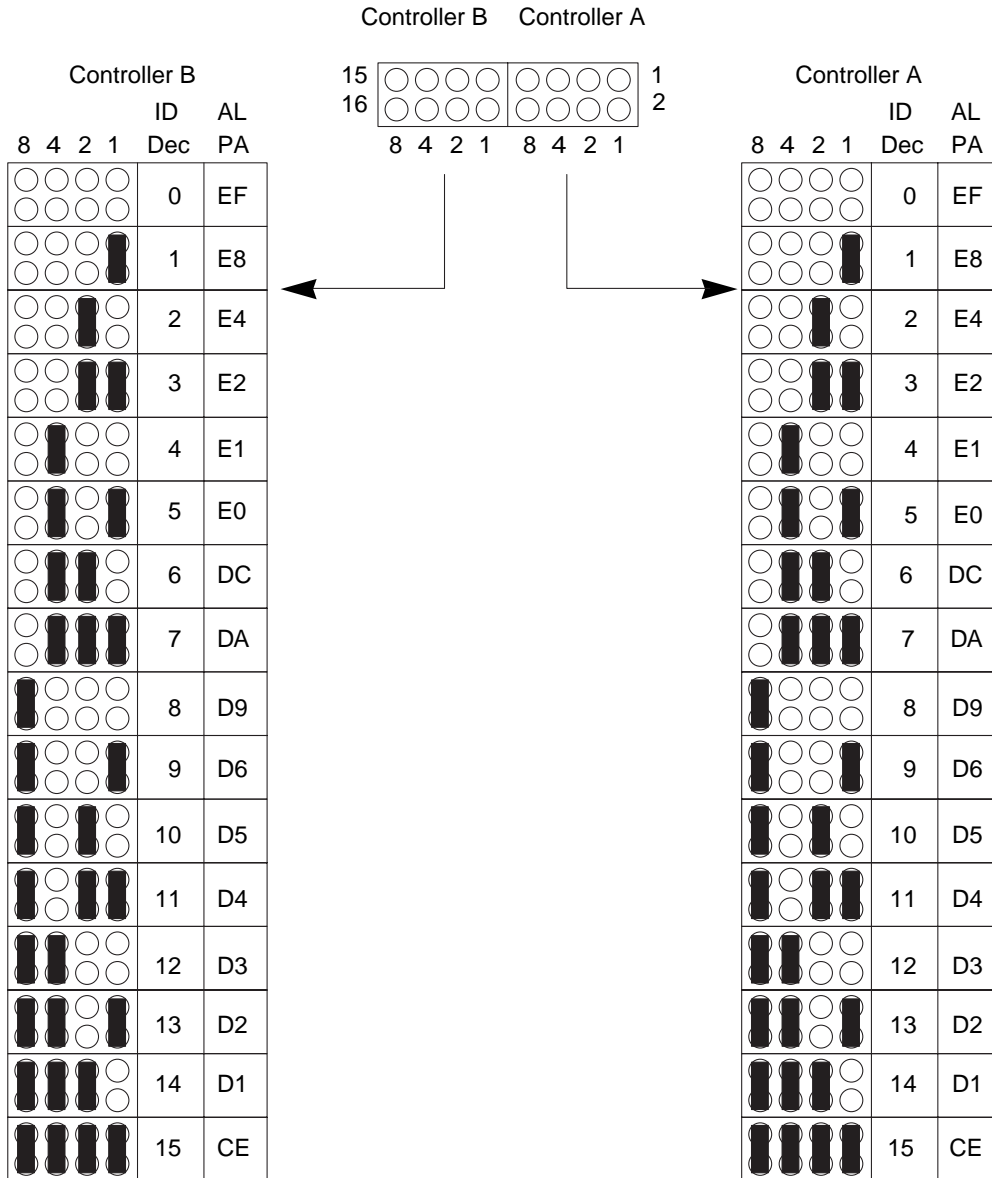

FIGURE 2-8 Controller Module FC-AL ID Settings

Sun StorEdge A3500/A3500FC Configurations

This chapter explains how to set up the following configurations:

- 1x2—One controller module with two StorEdge D1000 disk arrays
- 1x5—One controller module with five StorEdge D1000 disk arrays
- 2x7—Two controller modules with seven StorEdge D1000 disk arrays
- 3x15—Three controller modules with fifteen StorEdge D1000 disk arrays

The topics covered in this chapter are:

- StorEdge D1000 Disk Array Settings—page 3-2
 - 1x2 Configuration—page 3-3
 - 1x5 Configuration—page 3-5
 - 2x7 Configuration—page 3-7
 - 3x15 Configuration—page 3-9
- 1x2 Cables and Connections—page 3-11
 - Driveside SCSI Connections—page 3-11
 - Power Connections—page 3-13
- 1x5 Cables and Connections—page 3-14
 - Driveside SCSI Connections—page 3-14
 - Power Connections—page 3-16
- 2x7 Cables and Connections—page 3-17
 - SCSI Cable Lengths—page 3-18
 - Power Connections—page 3-19
- 3x15 Cables and Connections—page 3-20
 - SCSI Cable Lengths—page 3-23
 - Connections Between Power Sequencers—page 3-25
 - Connections to AC Power Sources—page 3-25
 - Power Connections for Expansion Cabinets—page 3-26

3.1 StorEdge D1000 Disk Array Settings

This section describes how to set attributes for the StorEdge D1000 disk arrays (FIGURE 3-1) in the following configurations:

- 1x2—One controller module with two StorEdge D1000 disk arrays
- 1x5—One controller module with five StorEdge D1000 disk arrays
- 2x7—Two controller modules with seven StorEdge D1000 disk arrays
- 3x15—Three controller modules with fifteen StorEdge D1000 disk arrays

For the D1000 disk arrays, you must set the following attributes:

- Option switch
- Module ID
- SCSI jumper cables and terminators

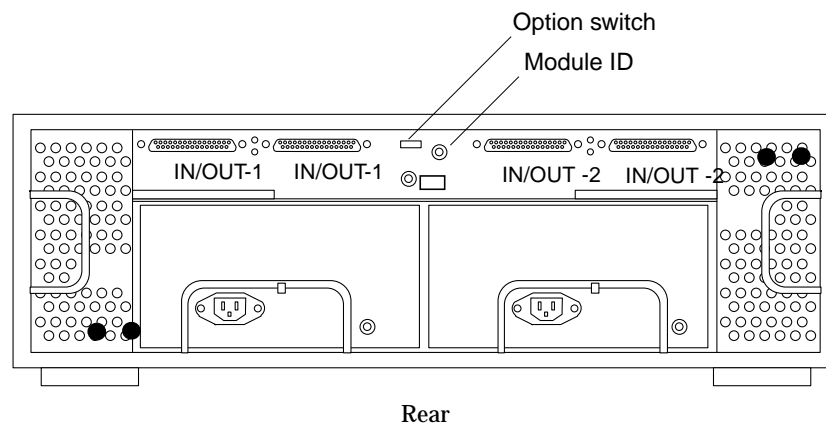

FIGURE 3-1 StorEdge D1000 Disk Array

3.1.1 1x2 Configuration

The 1x2 configuration includes one controller module with two StorEdge D1000 disk arrays.

Note – The 1x2 configuration is not qualified on the A3500FC controller module.

3.1.1.1 Option Switch

Both disk arrays have split buses. Their option switches should be set as shown in FIGURE 3-2.

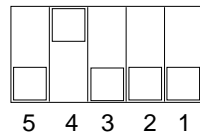

FIGURE 3-2 1x2 Option Switch Settings for StorEdge D1000 Disk Array

This setting will cause the disk drives in the StorEdge D1000 disk arrays to be numbered as shown in FIGURE 3-3 and FIGURE 3-4.

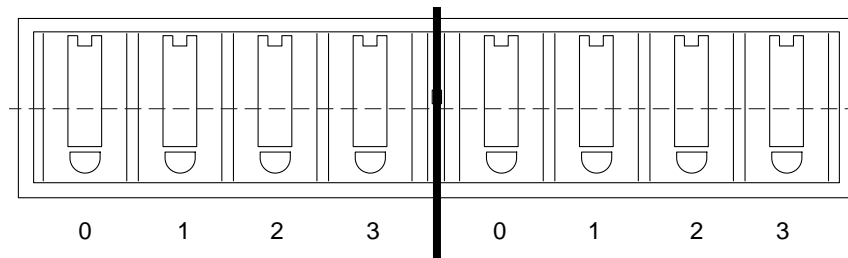

FIGURE 3-3 8-Drive StorEdge D1000 SCSI ID (Split Bus)

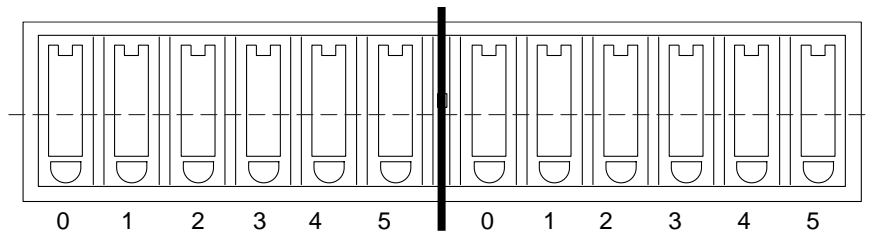

FIGURE 3-4 12-Drive StorEdge D1000 SCSI Disk ID (Split Bus)

3.1.1.2 Module ID Switch

Ensure that the module IDs for the StorEdge D1000 disk arrays are set according to TABLE 3-1.

TABLE 3-1 1x2 Module ID Switch Settings

Disk array number	Module ID setting
2 (Top)	2
1 (Bottom)	1

Note – Since the top and bottom disk arrays are split between one controller module, the Module IDs will overlap. This may result in error messages while the host system is booting. The ASC/ASCQ codes for this error is 98/01, and the Sense Key is 6. These error messages are information only and will not impact system performance.

3.1.1.3 SCSI Jumper Cables and Terminators

The StorEdge D1000 disk arrays should have differential SCSI terminators on the inside IN/OUT-1 and IN/OUT-2 SCSI connectors. This configuration is shown in FIGURE 3-11.

3.1.2 1x5 Configuration

The 1x5 configuration includes one controller module with five StorEdge D1000 disk arrays.

3.1.2.1 Option Switch

All StorEdge D1000 disk arrays in this configuration should have their option switches set as shown in FIGURE 3-5.

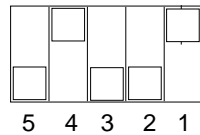

FIGURE 3-5 1x5 Option Switch Settings for StorEdge D1000 Disk Array

This will cause the disk drives in the StorEdge D1000 disk arrays to be numbered as shown in FIGURE 3-6 and FIGURE 3-7.

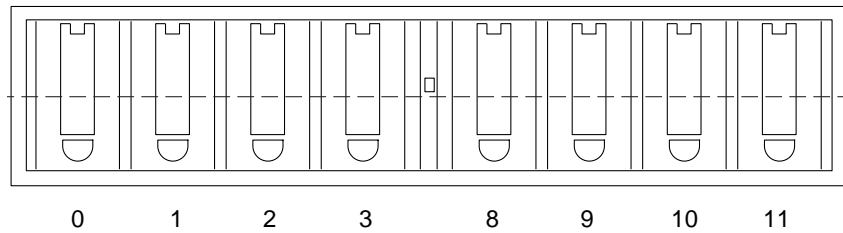

FIGURE 3-6 8-Drive StorEdge D1000 SCSI ID (Single Bus)

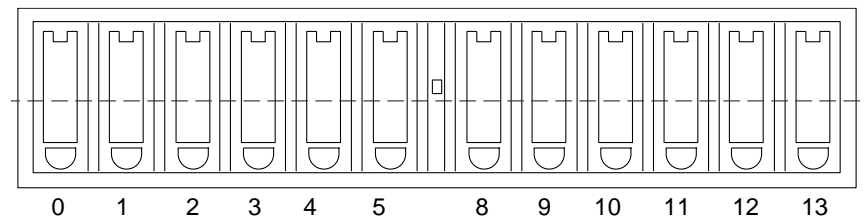

FIGURE 3-7 12-Drive StorEdge D1000 SCSI ID (Single Bus)

3.1.2.2 Module ID Switch

Ensure that the module IDs for the StorEdge D1000 disk arrays are set according to TABLE 3-2.

TABLE 3-2 1x5 Module ID Switch Settings

Disk Array Number	Module ID Setting
5 (Top)	5
4	4
3	3
2	2
1 (Bottom)	1

3.1.2.3 SCSI Jumper Cables and Terminators

All Sun StorEdge D1000 disk arrays in this configuration should have SCSI jumper cables between the middle SCSI connectors (IN/OUT-1 and IN/OUT-2) and a differential SCSI terminator in the far right SCSI connector (IN/OUT-2). This configuration is shown in FIGURE 3-15.

3.1.3 2x7 Configuration

The 2x7 configuration includes two controller modules with seven StorEdge D1000 disk arrays.

3.1.3.1 Option Switch

In FIGURE 3-17, the disk drives in each of the *top* four disk arrays are on a single bus and should be set as described in Section 3.1.2.1 “Option Switch” on page 3-5. The *bottom* three disk arrays have split buses. Their option switches should be set as shown in FIGURE 3-8.

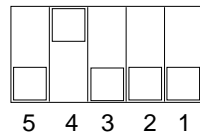

FIGURE 3-8 2x7 Option Switch Settings for StorEdge D1000 Disk Array

This will cause the disk drives in the StorEdge D1000 disk arrays to be numbered as shown in FIGURE 3-9 and FIGURE 3-10.

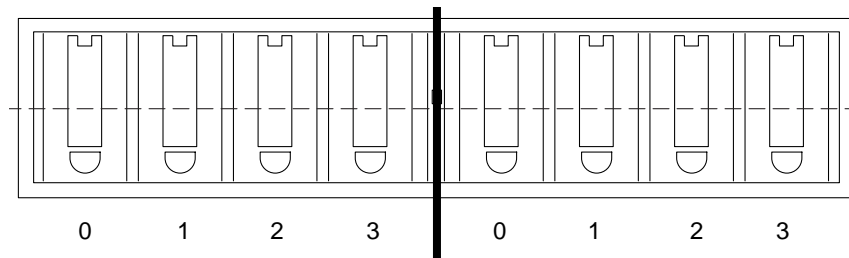

FIGURE 3-9 8-Drive StorEdge D1000 SCSI ID (Split Bus)

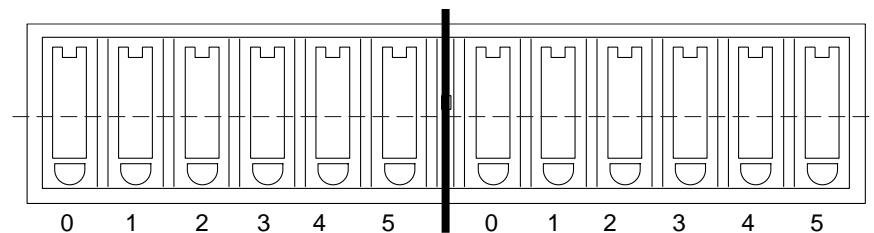

FIGURE 3-10 12-Drive StorEdge D1000 SCSI Disk ID (Split Bus)

3.1.3.2 Module ID Switch

Ensure that the module IDs for the StorEdge D1000 disk arrays are set according to TABLE 3-3.

TABLE 3-3 2x7 Module ID Switch Settings

Disk Array Number	Module ID Setting
7 (Top)	5
6	4
5	5
4	4
3	3
2	2
1 (Bottom)	1

In this configuration (from the front of the expansion cabinet), the following occurs:

- Controller module A controls the right side of disk arrays 1 through 3 and all of disk arrays 4 and 5.
- Controller module B controls the left side of disk arrays 1 through 3 and all of disk arrays 6 and 7.

This configuration is shown in FIGURE 3-17.

3.1.3.3 SCSI Jumper Cables and Terminators

The *top* four StorEdge D1000 disk arrays should have SCSI jumper cables between the middle SCSI connectors (IN/OUT-1 and IN/OUT-2) and a differential SCSI terminator in the far right SCSI connector (IN/OUT-2).

The *bottom* three StorEdge D1000 disk arrays should have differential SCSI terminators on the inside IN/OUT-1 and IN/OUT-2 SCSI connectors. This configuration is shown in FIGURE 3-17.

3.1.4 3x15 Configuration

The 3x15 configuration includes three controller modules with a total of fifteen StorEdge D1000 disk arrays combined in a 2x7 cabinet or a 1x8 cabinet.

3.1.4.1 Option Switch

All disk arrays are on a single bus and should be set as described in Section 3.1.2.1 “Option Switch” on page 3-5.

3.1.4.2 Module ID Switch

Ensure that the module IDs for the StorEdge D1000 disk arrays are set according to TABLE 3-4 and TABLE 3-5.

TABLE 3-4 3x15 Module ID Switch Settings in the 2x7 Cabinet

Disk Array Number	Module ID Setting
7 (Top)	5
6	4
5	3
4	2
3	1
2	1
1 (Bottom)	2

TABLE 3-5 3x15 Module ID Switch Settings in the 1x8 Cabinet

Disk Array Number	Module ID Setting
8 (Top)	5
7	4
6	3
5	2
4	1
3	5
2	4
1 (Bottom)	3

In this configuration (from the front of the expansion cabinet), the following occurs:

- Controller module A controls disk arrays 1 and 2 in the 2x7 cabinet and disk arrays 1 through 3 in the 1x8 cabinet (FIGURE 3-19).
- Controller module B controls disk arrays 3 through 7 in the 2x7 cabinet (FIGURE 3-20).
- Controller module C controls disk arrays 4 through 8 in the 1x8 cabinet (FIGURE 3-21).

3.1.4.3 SCSI Jumper Cables and Terminators

All StorEdge D1000 disk arrays in this configuration should have SCSI jumper cables between the middle SCSI connectors (IN/OUT-1 and IN/OUT-2) and a differential SCSI terminator in the far right SCSI connector (IN/OUT-2).

3.2 1x2 Cables and Connections

This section contains information about SCSI and power connections for one StorEdge A3500 with two StorEdge D1000 disk arrays.

Note – The 1x2 configuration is not qualified on the A3500FC controller module.

In the 1x2 configuration, the controller module can be either on top of or below the two disk arrays. Both configurations are described in this section.

Tip – Do not place the controller module at the bottom of the rack because the controller board diagnostic LEDs will not be visible.

3.2.1 Driveside SCSI Connections

The following table shows the length of each SCSI cable connected to the drive connections on the controller module.

TABLE 3-6 Controller Module A (1x2) Cables

SCSI Port Number	Cable Length	Part Number
1	0.8m/2.6 ft	530-1884
2	0.8m/2.6 ft	530-1884
3	0.8m/2.6 ft	530-1884
4	0.8m/2.6 ft	530-1884
5	Differential SCSI terminator	150-1890

The inboard IN/OUT connectors on each disk array are terminated with a differential SCSI terminator, part number 150-1890.

FIGURE 3-11 and FIGURE 3-12 show the SCSI connections between the StorEdge A3500 controller module and the two StorEdge D1000 disk arrays.

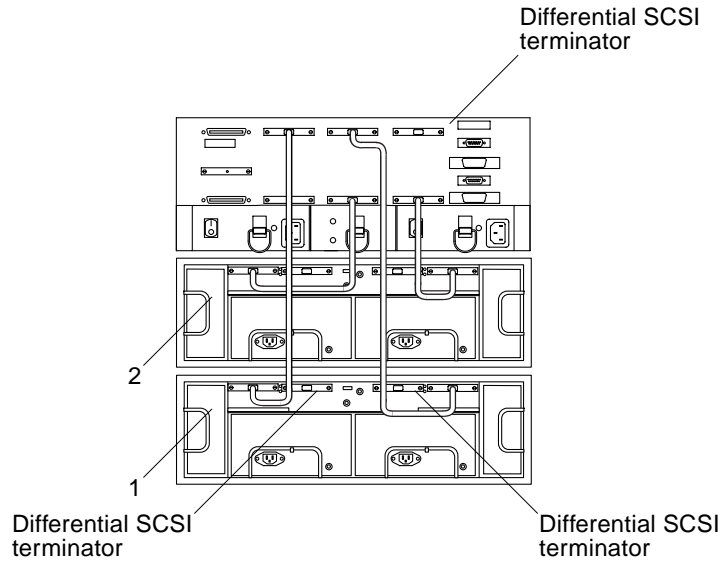

FIGURE 3-11 One StorEdge A3500 Controller Module and Two StorEdge D1000 Disk Arrays (SCSI)

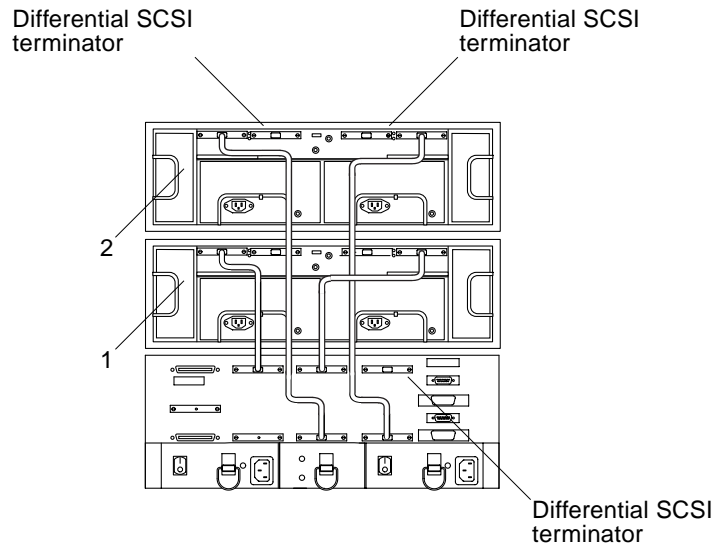

FIGURE 3-12 Two StorEdge D1000 Disk Arrays and One StorEdge A3500 Controller Module (SCSI)

3.2.2 Power Connections

Because the controller module must receive power *after* the disk arrays, connect the disk arrays to the first stage of the power sequencer and the controller module to the second. Two examples are shown in FIGURE 3-13 and FIGURE 3-14.

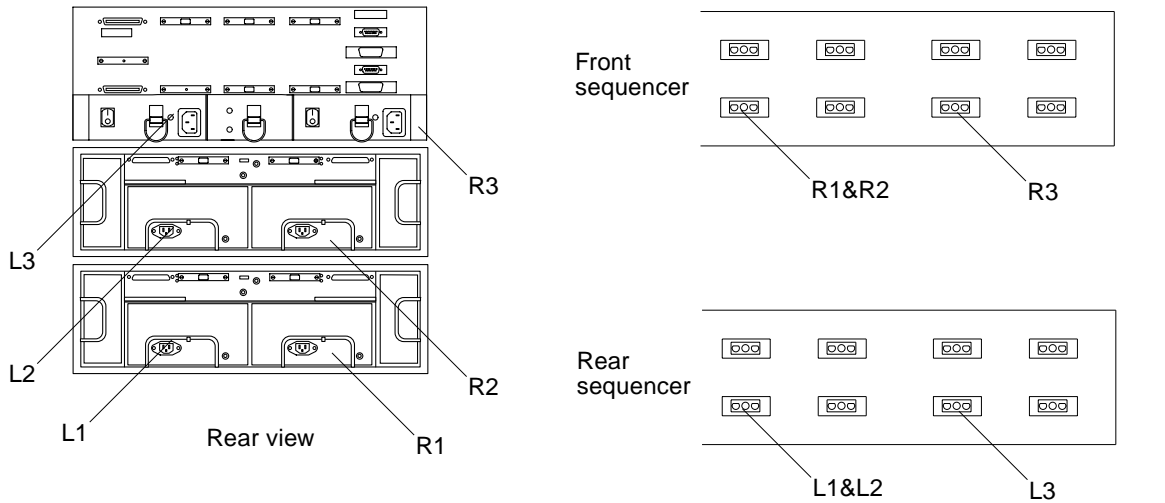

FIGURE 3-13 One StorEdge A3500 Controller Module and Two StorEdge D1000 Disk Arrays (Power)

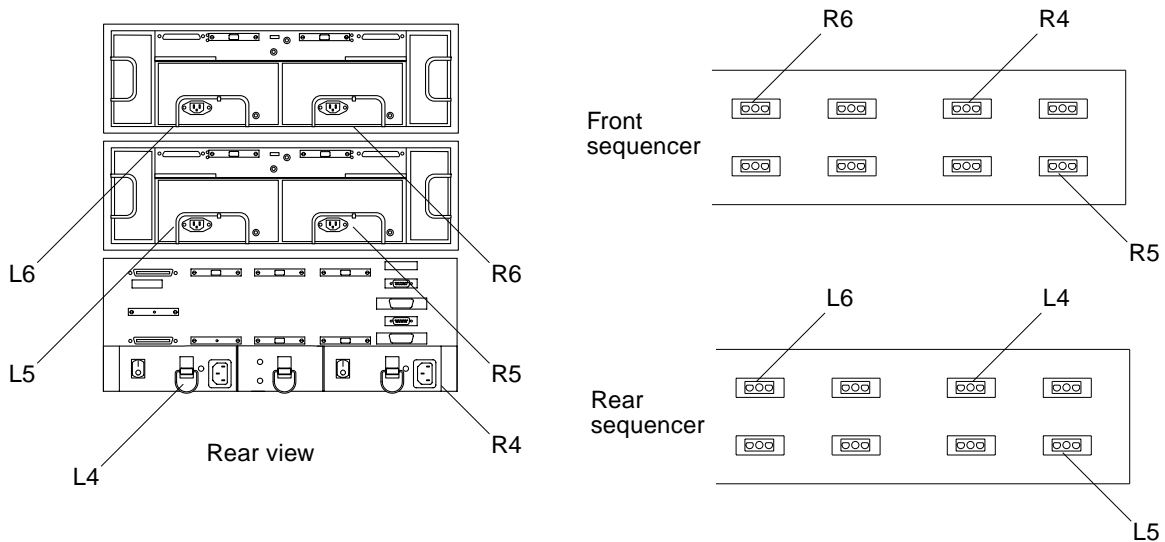

FIGURE 3-14 Two StorEdge D1000 Disk Arrays and One StorEdge A3500 Controller Module (Power)

3.3 1x5 Cables and Connections

This section contains information about SCSI, FC-AL, and power connections for one StorEdge A3500, or one StorEdge A3500FC controller module, with five StorEdge D1000 disk arrays.

3.3.1 Driveside SCSI Connections

The following table shows the lengths of each SCSI cable connected to the drive connections on the controller module.

TABLE 3-7 Controller Module A (1x5) Cables

SCSI Port Number	Cable Length	Part Number
1	2.0m/6.5 ft	530-1885
2	2.0m/6.5 ft	530-1885
3	2.0m/6.5 ft	530-1885
4	2.0m/6.5 ft	530-1885
5	2.0m/6.5 ft	530-1885

The inboard IN/OUT connectors on each of the disk arrays are connected using a 0.2m/0.65 ft SCSI jumper cable, part number 530-1883.

The outboard IN/OUT-2 connector on each disk array is terminated with a differential SCSI terminator, part number 150-1890.

FIGURE 3-15 shows the SCSI connections between the A3500 controller module and the five D1000 disk arrays.

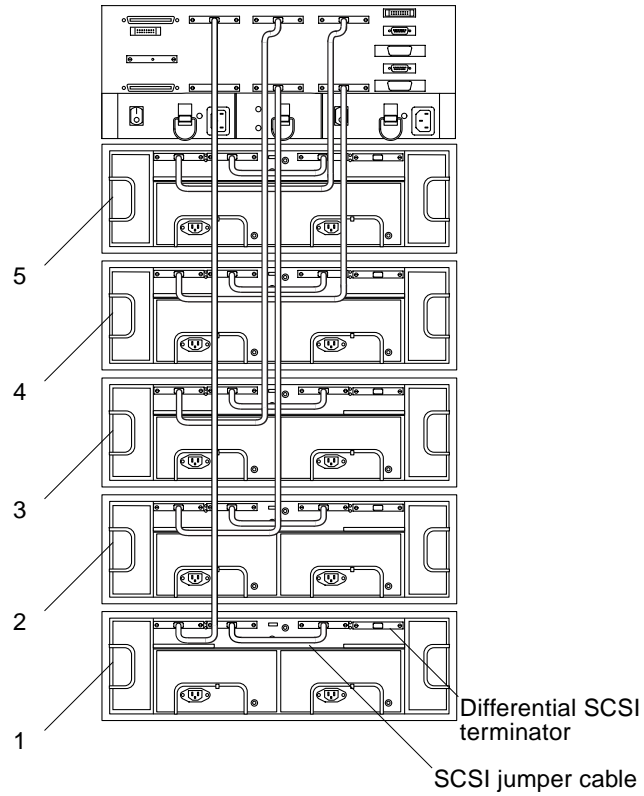

FIGURE 3-15 One StorEdge A3500 Controller Module and Five StorEdge D1000 Disk Arrays (SCSI)

3.3.2 Power Connections

FIGURE 3-16 shows the power connections for 1x5 configurations.

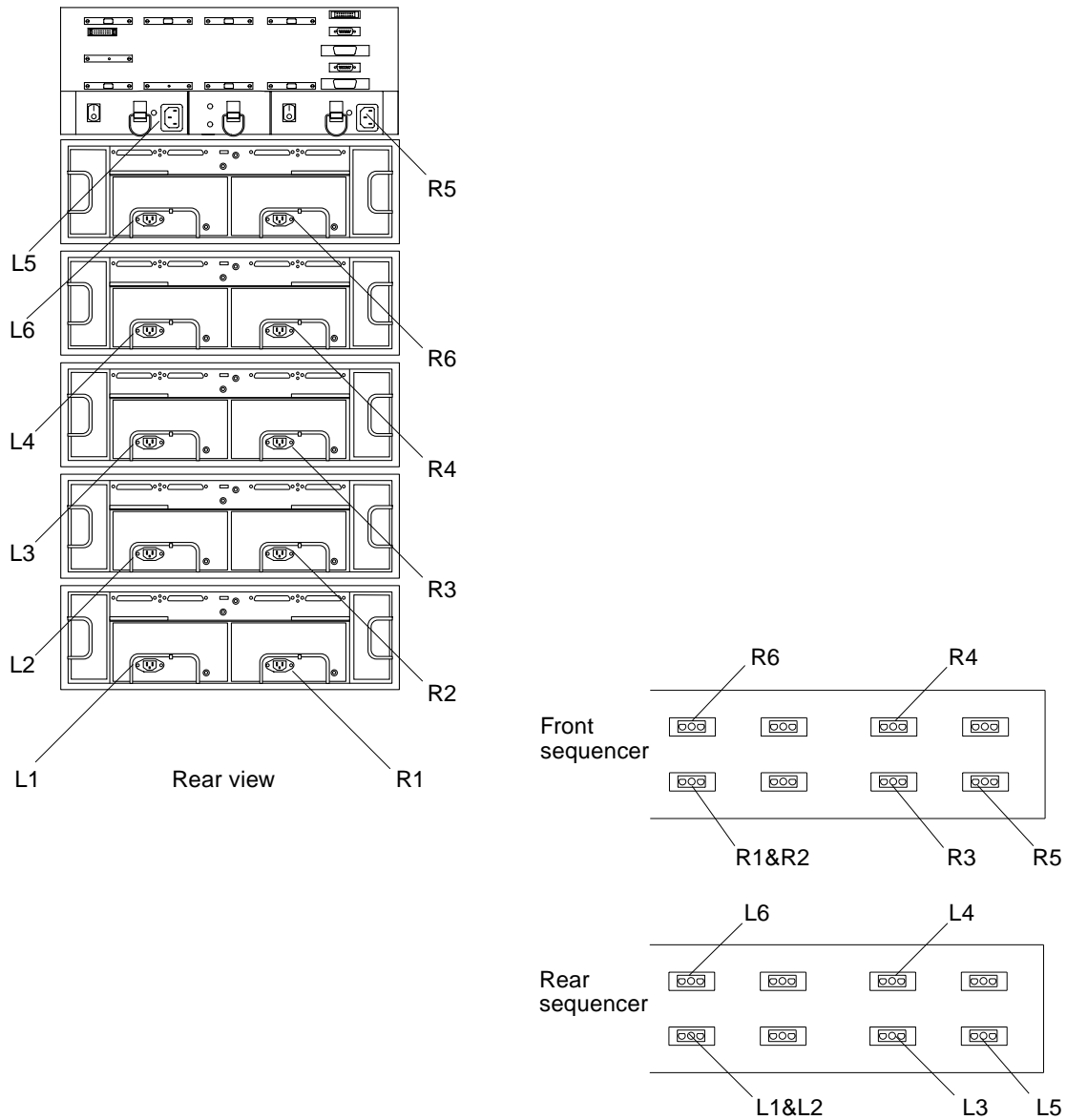

FIGURE 3-16 One StorEdge A3500 or A3500FC Controller Module and Five StorEdge D1000 Disk Arrays (Power)

3.4 2x7 Cables and Connections

This section contains information about SCSI, FC-AL, and power connections for two StorEdge A3500 controller modules, or two StorEdge A3500FC controller modules, with seven StorEdge D1000 disk arrays.

3.4.1 SCSI Cable Lengths

The following tables show the lengths of each SCSI cable connected to the drive connections on the respective controller modules.

TABLE 3-8 Controller Module A (2x7) Cables

SCSI Port Number	Cable Length	Part Number
1	0.8m/2.6 ft	530-1884
2	0.8m/2.6 ft	530-1884
3	0.8m/2.6 ft	530-1884
4	2.0m/6.5 ft	530-1885
5	2.0m/6.5 ft	530-1885

TABLE 3-9 Controller Module B (2x7)

SCSI Port Number	Cable Length	Part Number
1	2.0m/6.5 ft	530-1885
2	0.8m/2.6 ft	530-1884
3	0.8m/2.6 ft	530-1884
4	2.0m/6.5 ft	530-1885
5	2.0m/6.5 ft	530-1885

The inboard IN/OUT connectors on each of the top four disk arrays are connected using a 0.2m/0.65 ft SCSI jumper cable, part number 530-1883.

The inboard IN/OUT connectors on the bottom three disk arrays are terminated with differential SCSI terminators, part number 150-1890.

FIGURE 3-17 shows the SCSI connections between the two StorEdge A3500 controller modules and the seven StorEdge D1000 disk arrays.

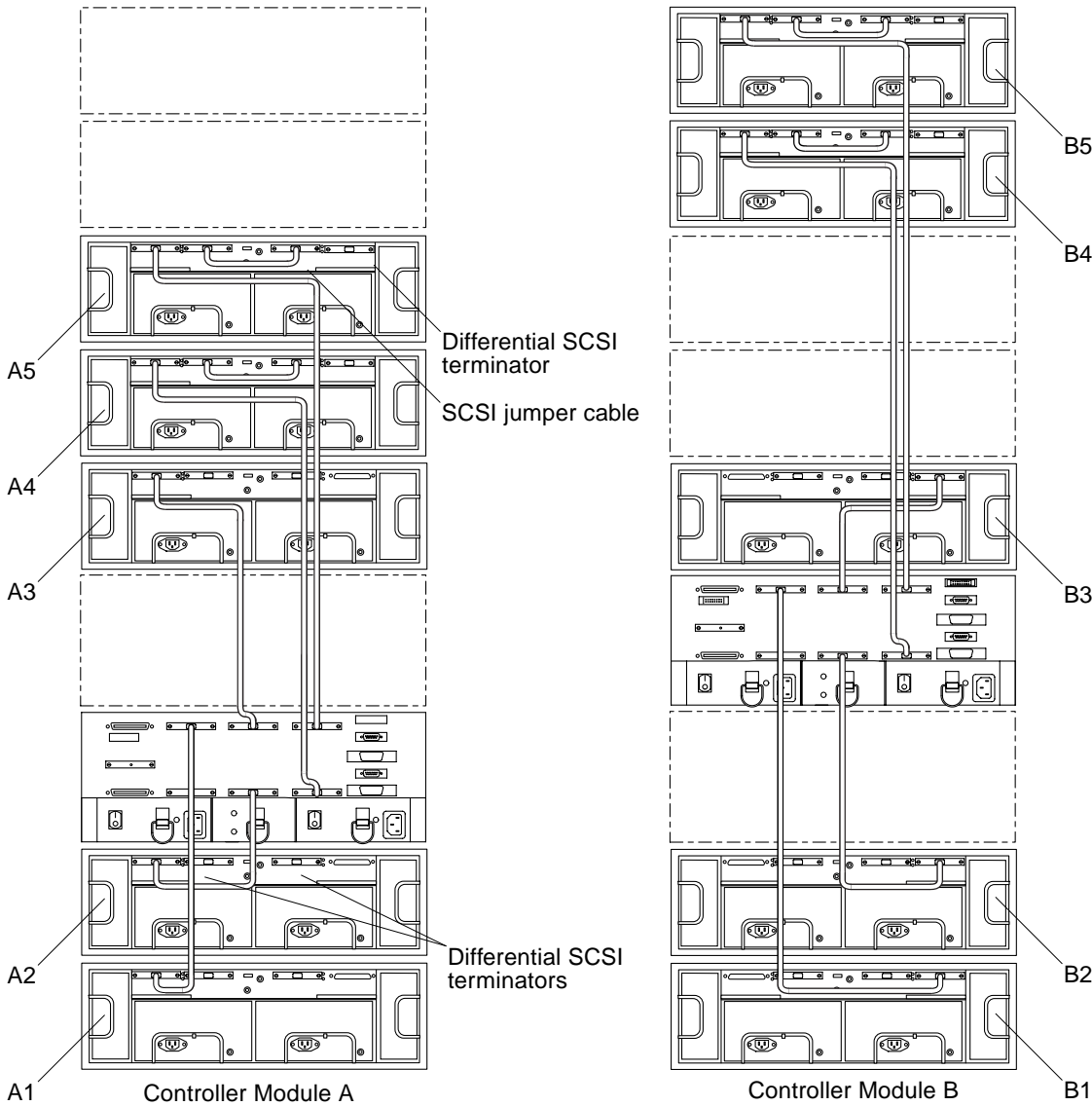

FIGURE 3-17 Two StorEdge A3500 Controller Modules and Seven StorEdge D1000 Disk Arrays (SCSI)

3.4.2 Power Connections

FIGURE 3-16 shows the power connections for 2x7 configurations.

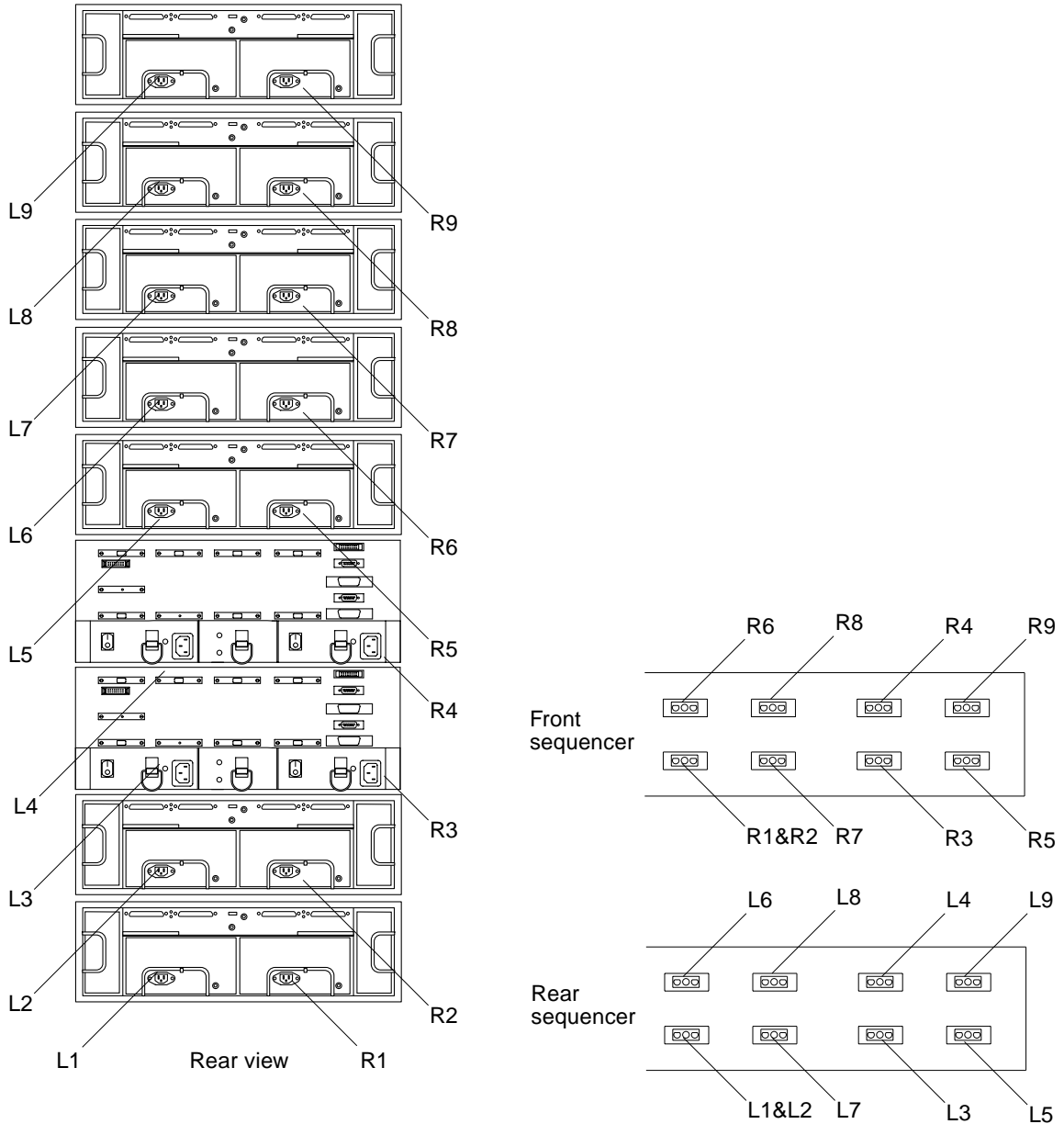

FIGURE 3-18 Two StorEdge A3500 or A3500FC Controller Modules and Seven StorEdge D1000 Disk Arrays (Power)

3.5 3x15 Cables and Connections

This section contains information about SCSI, FC-AL, and power connections for three StorEdge A3500 controller modules, or three StorEdge A3500FC controller modules, with fifteen StorEdge D1000 disk arrays in either the 2x7 StorEdge expansion cabinet or the 1x8 StorEdge expansion cabinet.



Caution – The components in the expansion cabinets are configured as a single unit. Make sure that the serial numbers on each expansion cabinet match.

3.5.1 SCSI Cable Lengths

The following tables show the lengths of each SCSI cable connected to the drive connections on the respective controller modules.

TABLE 3-10 Controller Module A (3x15 Configuration) Cables

SCSI Port Number	Cable Length	Part Number
1	0.8m/2.6 ft	530-1884
2	0.8m/2.6 ft	530-1884
3	4.0m/13.1 ft	530-2352
4	4.0m/13.1 ft	530-2352
5	4.0m/13.1 ft	530-2352

TABLE 3-11 Controller Module B (3x15 Configuration) Cables

SCSI Port Number	Cable Length	Part Number
1	0.8m/2.6 ft	530-1884
2	0.8m/2.6 ft	530-1884
3	2.0m/6.5 ft	530-1885
4	2.0m/6.5 ft	530-1885
5	2.0m/6.5 ft	530-1885

TABLE 3-12 Controller Module C (3x15 Configuration) Cables

SCSI Port Number	Cable Length	Part Number
1	0.8m/2.6 ft	530-1884
2	0.8m/2.6 ft	530-1884
3	2.0m/6.5 ft	530-1885
4	2.0m/6.5 ft	530-1885
5	2.0m/6.5 ft	530-1885

The inboard IN/OUT connectors on each of the disk arrays are connected using a 0.2m/0.65 ft SCSI jumper cable, part number 530-1883.

The outboard IN/OUT-2 connector on each disk array is terminated with a differential SCSI terminator, part number 150-1890.

FIGURE 3-19 shows the SCSI connections for controller module A.

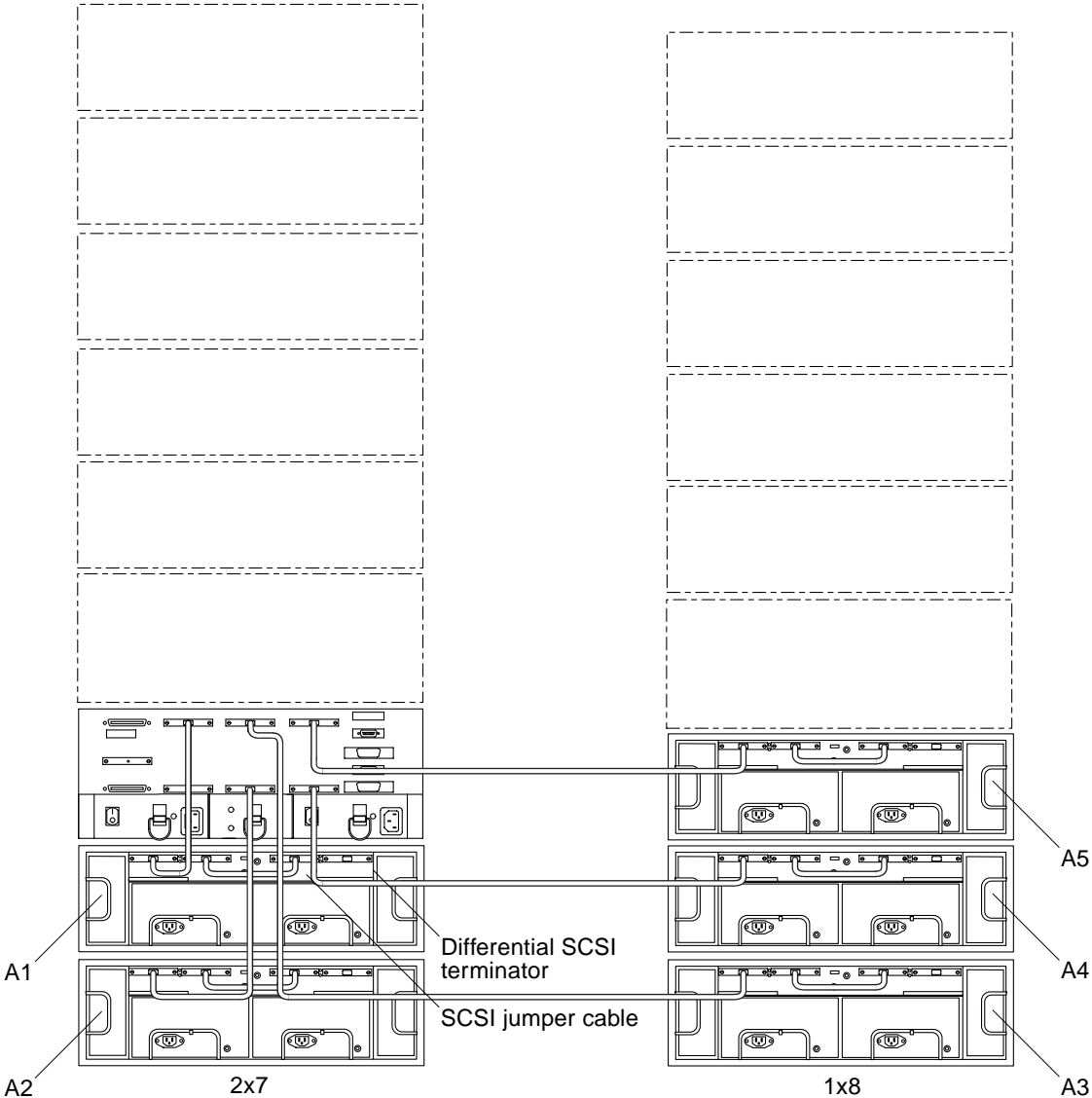

FIGURE 3-19 Controller Module A—3x15 Configuration

FIGURE 3-20 shows the SCSI connections for controller module B.

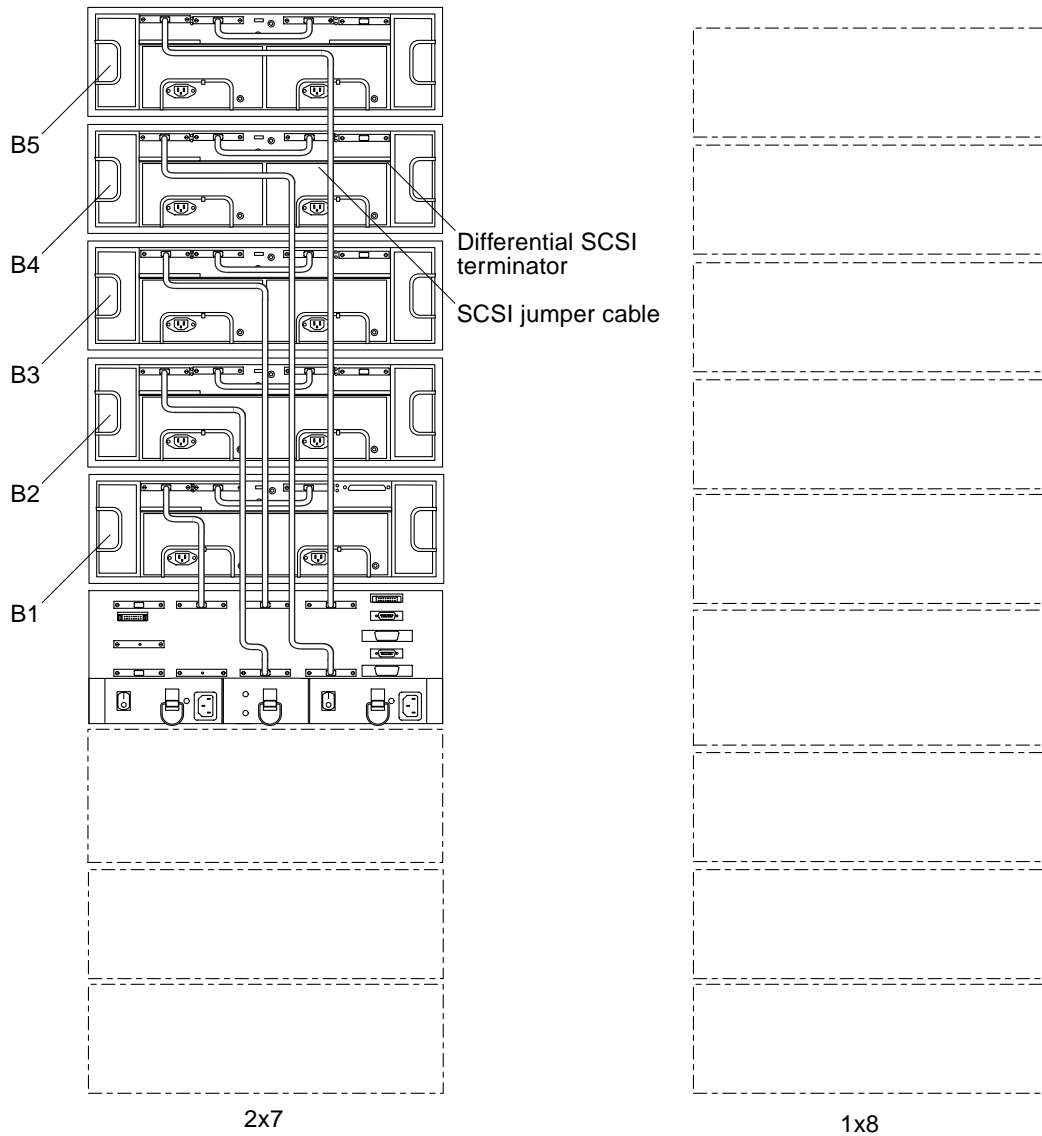

FIGURE 3-20 Controller Module B—3x15 Configuration

FIGURE 3-21 shows the SCSI connections for controller module C.

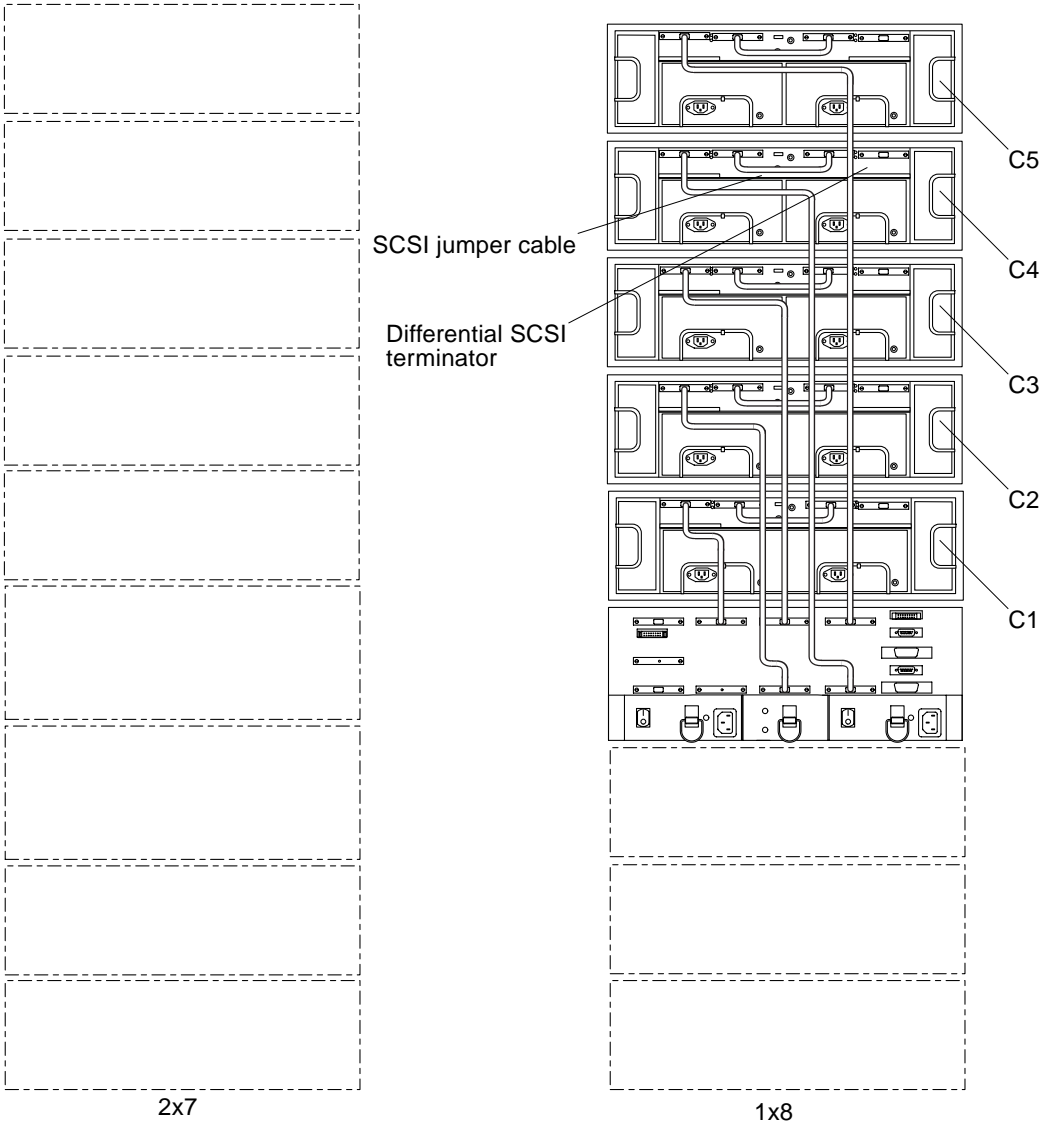

FIGURE 3-21 Controller Module C—3x15 Configuration

3.5.2 Connections Between Power Sequencers

The front and rear power sequencers in the 2x7 expansion cabinet and the 1x8 expansion cabinet must be interconnected. Make sure an interconnect cable (part number 530-2325) is connected between the OUT on the front sequencer in the 2x7 expansion cabinet and the IN on the front sequencer in the 1x8 expansion cabinet (FIGURE 3-22). Make sure that the rear sequencers are likewise connected.

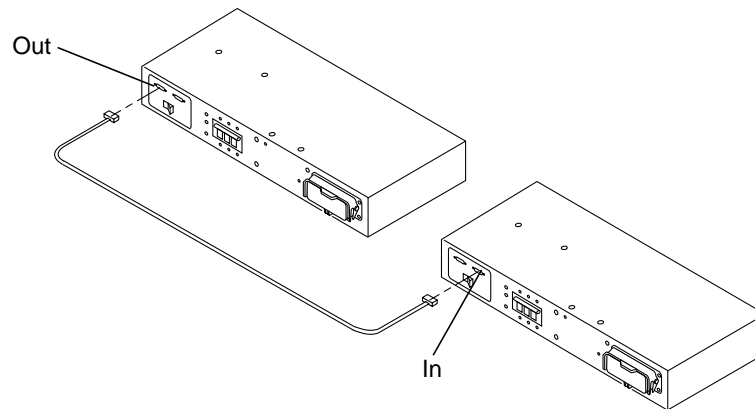

FIGURE 3-22 Connecting the Power Sequencers

3.5.3 Connections to AC Power Sources

Each of the AC power cords connected to the expansion cabinets should be on independent circuit breakers.

To ensure proper redundancy, if independent circuit breaker boxes or AC power sources are used, make sure that power cords from the same expansion cabinet are connected to different circuit breaker boxes or AC power sources.



Caution – Ensure that the second rack will not lose power before the first rack loses power. Data loss is likely to occur if this happens. Do *not* configure the 3x15 expansion cabinets as shown in FIGURE 3-23 and FIGURE 3-24. Consult with an electrician if you do not understand the schematics in these figures.

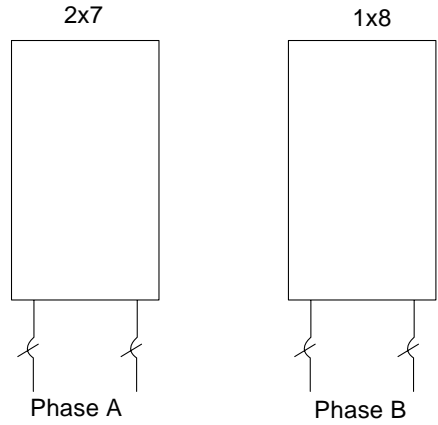

FIGURE 3-23 Power Connections to Avoid (Different Phases)

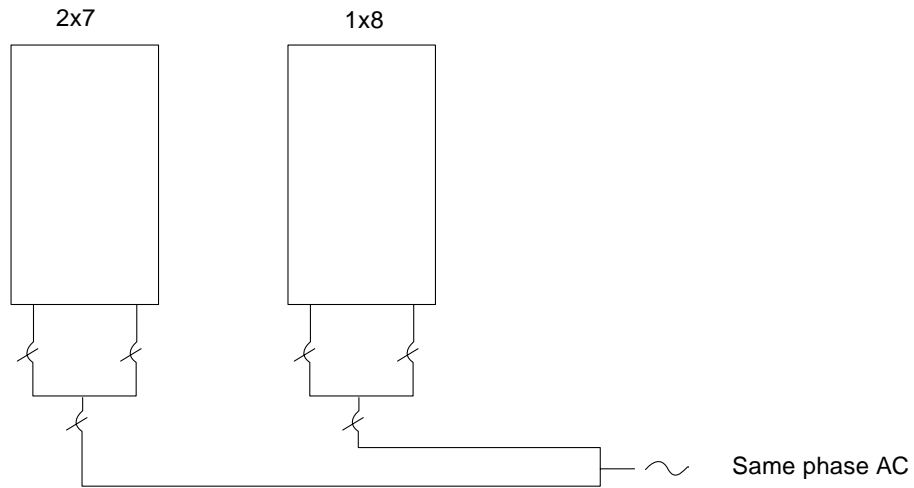

FIGURE 3-24 Power Connections to Avoid (Same Phase)

3.5.4 Power Connections for Expansion Cabinets

The power connections for the 2x7 expansion cabinet are the same as those in the standard 2x7 expansion cabinet (FIGURE 3-18).

The power connections for the 1x8 expansion cabinet are shown in FIGURE 3-25.

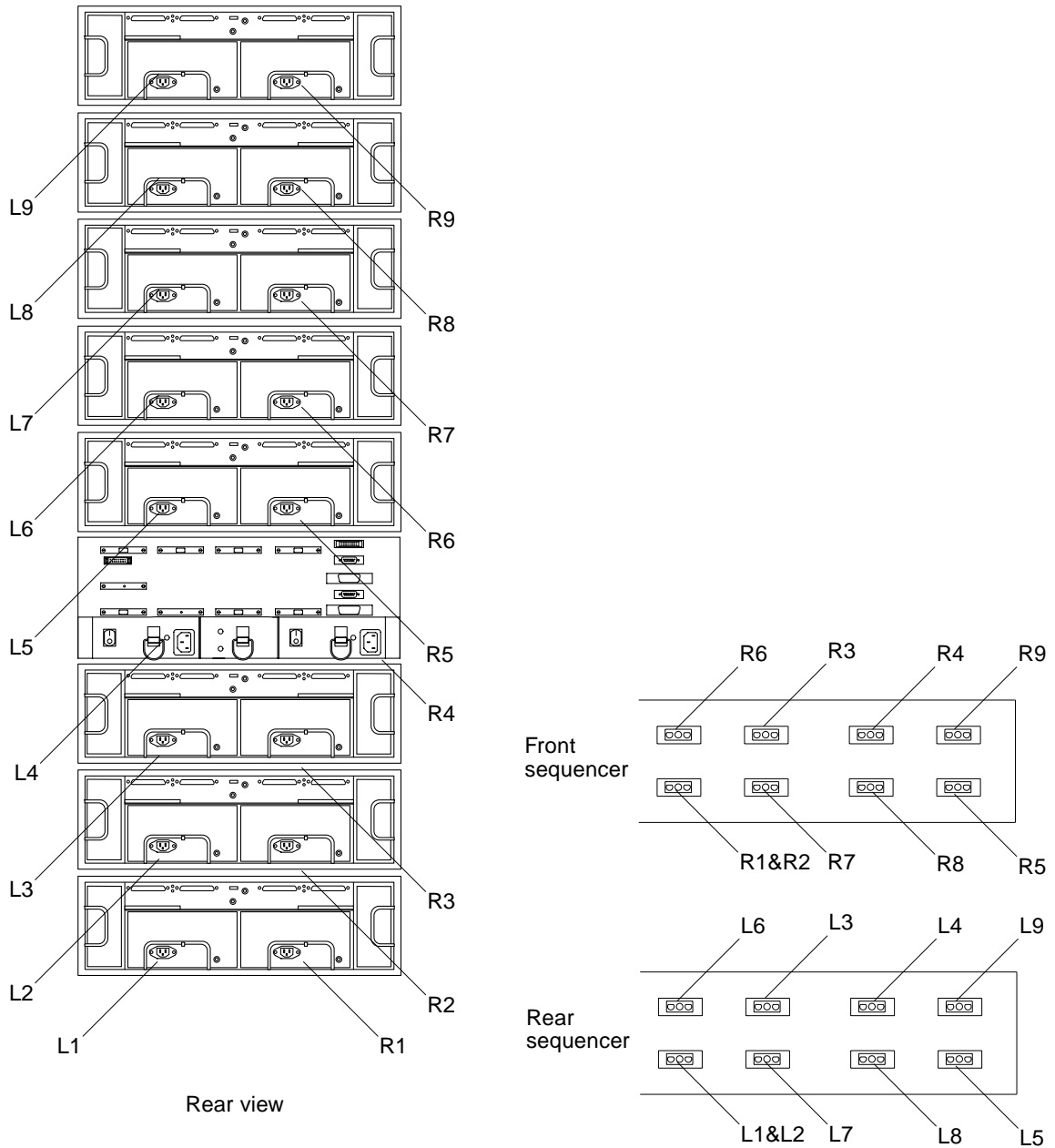

FIGURE 3-25 One StorEdge A3500 or A3500FC Controller Module and Eight StorEdge D1000 Disk Arrays (Power)

Sun StorEdge A3500 and A3500FC Specifications

A.1 Initial Cold Start Surge Current Specifications

The following tables provide the initial cold start surge specifications for the StorEdge A3500 and A3500FC systems.

TABLE A-1 Device Surge Current Specifications

Device	Specification for Each Power Supply
StorEdge A3x00 controller module	25A rms or 35A peak for one line cycle
RSM™ disk array	15A rms or 21A peak for one line cycle
StorEdge D1000 disk array	11A rms or 22A peak for one line cycle

TABLE A-2 Cabinet Surge Current Specifications

Device	Specification for Each Power Cord
StorEdge A3000 (StorEdge A3000 controller module with RSM disk arrays in 1422mm/56-in. cabinet):	
1x5 configuration	120A rms or 169A peak for one line cycle
StorEdge A3500 (StorEdge A3000 controller with StorEdge D1000 disk arrays in 1828mm/72-in. cabinet):	
1x5 configuration	44A rms or 88A peak for one line cycle
2x7 configuration	72A rms or 114A peak for one line cycle
1x8 configuration	55A rms or 110A peak for one line cycle