

Sun StorEdge™ RAID Manager 6.22 Installation and Support Guide for Solaris™



THE NETWORK IS THE COMPUTER™

Sun Microsystems, Inc.
901 San Antonio Road
Palo Alto, CA 94303-4900 USA
650 960-1300 Fax 650 969-9131

Part No. 805-7756-10
September 1999, Revision A

Send comments about this document to: docfeedback@sun.com

Copyright 1999 Sun Microsystems, Inc., 901 San Antonio Road • Palo Alto, CA 94303 USA. All rights reserved.
Portions copyright 1999 LSI Logic, Inc. All rights reserved.

This product or document is protected by copyright and distributed under licenses restricting its use, copying, distribution, and decompilation. No part of this product or document may be reproduced in any form by any means without prior written authorization of Sun and its licensors, if any. Third-party software, including font technology, is copyrighted and licensed from Sun suppliers.

Parts of the product may be derived from Berkeley BSD systems, licensed from the University of California. UNIX is a registered trademark in the U.S. and other countries, exclusively licensed through X/Open Company, Ltd. For Netscape Communicator™, the following notice applies: Copyright 1995 Netscape Communications Corporation. All rights reserved.

Sun, Sun Microsystems, the Sun logo, AnswerBook, docs.sun.com, OpenWindows, Solaris, Sun Enterprise Volume Manager, and StorEdge are trademarks, registered trademarks, or service marks of Sun Microsystems, Inc. in the U.S. and other countries. All SPARC trademarks are used under license and are trademarks or registered trademarks of SPARC International, Inc. in the U.S. and other countries. Products bearing SPARC trademarks are based upon an architecture developed by Sun Microsystems, Inc. The OPEN LOOK and Sun™ Graphical User Interface was developed by Sun Microsystems, Inc. for its users and licensees. Sun acknowledges the pioneering efforts of Xerox in researching and developing the concept of visual or graphical user interfaces for the computer industry. Sun holds a non-exclusive license from Xerox to the Xerox Graphical User Interface, which license also covers Sun's licensees who implement OPEN LOOK GUIs and otherwise comply with Sun's written license agreements.

RESTRICTED RIGHTS: Use, duplication, or disclosure by the U.S. Government is subject to restrictions of FAR 52.227-14(g)(2)(6/87) and FAR 52.227-19(6/87), or DFAR 252.227-7015(b)(6/95) and DFAR 227.7202-3(a).

DOCUMENTATION IS PROVIDED "AS IS" AND ALL EXPRESS OR IMPLIED CONDITIONS, REPRESENTATIONS AND WARRANTIES, INCLUDING ANY IMPLIED WARRANTY OF MERCHANTABILITY, FITNESS FOR A PARTICULAR PURPOSE OR NON-INFRINGEMENT, ARE DISCLAIMED, EXCEPT TO THE EXTENT THAT SUCH DISCLAIMERS ARE HELD TO BE LEGALLY INVALID.

Copyright 1999 Sun Microsystems, Inc., 901 San Antonio Road • Palo Alto, CA 94303 Etats-Unis. Tous droits réservés.
Des portions de ce produit sont protégées par un copyright (1999) de LSI Logic, Inc. Tous droits réservés.

Ce produit ou document est protégé par un copyright et distribué avec des licences qui en restreignent l'utilisation, la copie, la distribution, et la décompilation. Aucune partie de ce produit ou document ne peut être reproduite sous aucune forme, par quelque moyen que ce soit, sans l'autorisation préalable et écrite de Sun et de ses bailleurs de licence, s'il y en a. Le logiciel détenu par des tiers, et qui comprend la technologie relative aux polices de caractères, est protégé par un copyright et licencié par des fournisseurs de Sun.

Des parties de ce produit pourront être dérivées des systèmes Berkeley BSD licenciés par l'Université de Californie. UNIX est une marque déposée aux Etats-Unis et dans d'autres pays et licenciée exclusivement par X/Open Company, Ltd. La notice suivante est applicable à Netscape Communicator™ : Copyright 1995 Netscape Communications Corporation. All rights reserved.

Sun, Sun Microsystems, le logo Sun, AnswerBook, docs.sun.com, OpenWindows, Solaris, Sun Enterprise Volume Manager, et StorEdge sont des marques de fabrique ou des marques déposées, ou marques de service, de Sun Microsystems, Inc. aux Etats-Unis et dans d'autres pays. Toutes les marques SPARC sont utilisées sous licence et sont des marques de fabrique ou des marques déposées de SPARC International, Inc. aux Etats-Unis et dans d'autres pays. Les produits portant les marques SPARC sont basés sur une architecture développée par Sun Microsystems, Inc. L'interface d'utilisation graphique OPEN LOOK et Sun™ a été développée par Sun Microsystems, Inc. pour ses utilisateurs et licenciés. Sun reconnaît les efforts de pionniers de Xerox pour la recherche et le développement du concept des interfaces d'utilisation visuelle ou graphique pour l'industrie de l'informatique. Sun détient une licence non exclusive de Xerox sur l'interface d'utilisation graphique Xerox, cette licence couvrant également les licenciés de Sun qui mettent en place l'interface d'utilisation graphique OPEN LOOK et qui en outre se conforment aux licences écrites de Sun.

CETTE PUBLICATION EST FOURNIE "EN L'ETAT" ET AUCUNE GARANTIE, EXPRESSE OU IMPLICITE, N'EST ACCORDEE, Y COMPRIS DES GARANTIES CONCERNANT LA VALEUR MARCHANDE, L'APTITUDE DE LA PUBLICATION A REPOUDRE A UNE UTILISATION PARTICULIERE, OU LE FAIT QU'ELLE NE SOIT PAS CONTREFAISANTE DE PRODUIT DE TIERS. CE DENI DE GARANTIE NE S'APPLIQUERAIT PAS, DANS LA MESURE OU IL SERAIT TENU JURIDIQUEMENT NUL ET NON AVENU.



Contents

1. Introduction	1
About This Guide	2
About This Software	3
What's New	3
Other Features	4
About the Installation Procedure	5
Understanding the Restrictions	6
Hardware and Software Requirements	9
Hardware Configuration	9
Operating Environment	10
Host Adapters, Hubs, and Switches	11
Checking the Hardware	11
Configuring the Solaris Environment to Support Sun StorEdge RAID Manager	12
Patches Required to Support the Solaris Operating Environment	12
The <code>rpmparams</code> File	13
Setting Up Other Scriptable Notification Options	14
SNMP Notification	14

2. Installing the Software on a Standard Configuration	15
Selecting the Appropriate Installation Procedure	16
Upgrading to Sun StorEdge RAID Manager 6.22	17
Requirements	17
▼ To Upgrade to RAID Manager 6.22	18
Installing the Sun StorEdge RAID Manager Software	20
▼ To Mount the CD-ROM	20
Sun StorEdge RAID Manager Installation Options	21
swmtool	21
pkgadd	21
▼ To Install RAID Manager Using swmtool	22
▼ To Install RAID Manager Using pkgadd	25
▼ To Verify the Installation	30
Removing an Earlier Version of Sun StorEdge RAID Manager	32
Deinstalling RAID Manager	33
3. Initial Startup	35
Setting the Logical Unit Limit	36
Setting the LUN Limit in the rmparams File	36
Setting the Controller's Fibre Channel Loop ID	38
Starting the Software	40
Setting Up Independent Controllers	42
Assigning Names to the Modules	43
Verifying and Upgrading Controller Firmware	44
Determining the Controller Firmware Version	44
Upgrading the Controller Firmware Version	45
Running Recovery Guru/Health Check	48
Completing the Installation	51

Determining the Current Configuration	52
Determining If Any Changes Are Necessary	58
Configuring RAID Modules	63
Configuring Logical Units on the RAID Module	63
Adding Logical Units to the Operating Environment	64
What's Next?	64
4. Customizing the Installation	65
Changing the <code>rmparms</code> File	66
▼ To Edit the <code>rmparms</code> File	67
Setting Up Scriptable Notification Options	70
Editing Example	70
Setting Up SNMP Notification	72
▼ To Set Up the NMS	72
▼ To Enable SNMP	73
Disabling SNMP	74
SNMP Trap Message Description	75
5. Operating Environment Support	77
Naming Conventions	78
Module Names	78
Controller and LUN Names	78
Creating and Deleting Logical Units	79
Number of LUNs	79
Creating LUNs	79
Deleting LUNs	80
The Background Monitor	81
Stopping the <code>arraymon</code> Process	81
Starting the <code>arraymon</code> Process	82

Using Sun StorEdge™ Volume Manager	82
Redundant Controller Support (RDAC)	83
Disabling RDAC	85
Command-Line Interface	86
man Pages	86
Adding New RAID Modules to the Configuration	87
Deinstalling RAID Manager	88

6. Troubleshooting 89

Resolving Problems	90
Locating Solutions	90
Category	91
Component Search	91
Application Search	94
Software Search	96
Configuration Application	97
Firmware Upgrade	99
General	100
Recovery Guru/Health Check	103
Replacing Controllers	107
Problems Bringing the New Controller Online	108
Problem Summary	108
Incompatible Firmware Detected	109
Problem Summary	109
Upgrading Firmware from 2.05.00 Through 2.05.03 to 3.X for a Replaced Controller In Slot A	113

A. Specifications	115
Hardware Specifications	116
Host-RAID Module Configurations	116
Host Systems	117
Host Adapters	117
SCSI Host Adapters	117
Fibre Channel Host Adapters	118
Boot Device Host Adapters	118
Fibre Channel Hubs	118
Fibre Channel Fabric Switches	118
Required Patches	119
▼ To Install Required Patches	119
Controller Firmware Upgrade Notes	121
Firmware Autosynch	122
Supporting The Modify Group/LUN Options	122
B. Reference Material	123
NVRAM Settings	123
rmparams File Listing	124
rmscript File Listing	128
man Pages	131

Figures

- FIGURE 3-3 Main Program Group 40
- FIGURE 3-4 Firmware Upgrade Screen 46
- FIGURE 3-5 Recovery Main Screen 48
- FIGURE 3-6 Recovery Screen/Exceptions Found 49
- FIGURE 3-7 Recovery Procedure Screen 50
- FIGURE 3-8 Configuration Application Main Screen 53
- FIGURE 3-9 Main Module Profile Screen 56
- FIGURE 5-1 Device Name Example 78
- FIGURE 5-2 Example of RDAC I/O Connection Redundancy 84

Tables

TABLE 1-1	Restrictions for the Solaris Operating Environment	6
TABLE 1-2	Required Changes for Solaris Operating Environment	12
TABLE 2-1	Package Descriptions	21
TABLE 2-2	Tasks Performed During Installation	26
TABLE 2-3	Tasks Performed During System Reboot	28
TABLE 2-4	Removing Earlier Versions of Sun StorEdge RAID Manager	32
TABLE 1	SCSI Host Adapters	36
TABLE 2	Fibre Channel Host Adapters	37
TABLE 3-1	Fibre Channel Loop ID Byte Definition	39
TABLE 3-2	Configuration Display Columns	54
TABLE 3-3	Possible Parameters to Change	59
TABLE 4-1	Changeable Parameters in <code>rmparams</code> File	68
TABLE 4-2	SNMP Trap Message Descriptions	75
TABLE 6-1	Troubleshooting Entries by Category	91
TABLE 6-2	Troubleshooting Entries Organized by Component	91
TABLE 6-3	Troubleshooting Entries Organized by Application	94
TABLE 6-4	Troubleshooting Entries Organized by Software	96
TABLE 6-5	Configuration Application Changes Troubleshooting	97
TABLE 6-6	Controller Firmware Upgrade Troubleshooting	99

TABLE 6-7	Troubleshooting Generally Applicable to All Applications	100
TABLE 6-8	Recovery Guru/Health Check Troubleshooting	103
TABLE 6-9	Determining Which Upgrade Procedure to Follow	110
TABLE A-1	Supported Platforms for Sun StorEdge A1000, A3000, and A3500	117
TABLE A-2	Supported SCSI Host Adapters	117
TABLE A-3	Supported Fibre Channel Host Adapters	118
TABLE A-4	Controller Firmware Upgrade	121

Introduction

This chapter introduces the Sun StorEdge™ RAID Manager software in the Solaris™ operating environment. It gives an overview of the RAID Manager storage management software, the hardware and software requirements, and the guidelines you must follow before installing the software.

Note – In this manual, the terms Sun StorEdge RAID Manager and RAID Manager are used interchangeably.

- About This Guide—page 2
- About This Software—page 3
- About the Installation Procedure—page 5
- Understanding the Restrictions—page 6
- Hardware and Software Requirements—page 9
- Configuring the Solaris Environment to Support Sun StorEdge RAID Manager—page 12
- SNMP Notification—page 14

Note – See “Common Definitions” in the *Sun StorEdge RAID Manager User’s Guide* or the Online Help glossary for an explanation of important RAID Manager terms.

About This Guide

The *Sun StorEdge RAID Manager Installation and Support Guide* provides installation, setup, and troubleshooting information for Sun StorEdge™ RAID Manager 6.22 in the Solaris operating environment.

Note – Before you attempt to install the RAID Manager software, be sure to read the *Sun StorEdge RAID Manager Release Notes* for the latest installation and operation procedures.

Use the *Installation and Support Guide* to:

- Determine the hardware and software required to install the storage management software
- Install the storage management software
- Set up software parameters
- Identify storage management features unique to the Solaris environment
- Troubleshoot the installation if necessary

In addition to this manual you also received the following manuals:

- *Sun StorEdge RAID Manager Release Notes* (805-7758-xx). This manual contains important information about the installation and operation of the Sun StorEdge RAID Manager software that was not available at the time this manual was published.
- *Sun StorEdge RAID Manager User's Guide* (806-0478-xx). This manual describes how to use the storage management software after installation. Once you have installed and set up the software, refer to this guide for information on using the software and maintaining the RAID Modules.

About This Software

Note – The Sun StorEdge RAID Manager 6.22 software is backward compatible with previously released firmware. However, the new features described in the following paragraphs are only available if the controller firmware level in both controllers is at 3.01.02.xx or higher.

What's New

This release of Sun StorEdge RAID Manager supports the following new features:

- **Support for the Solaris 2.6 and Solaris 7 operating environments.**
- **Faster Logical Unit (LUN) creation.** The controller performs background formatting to create logical units faster.
- **SMART/PFA support.** Through the use of Self-Monitoring Analysis and Reporting Technology (SMART), the storage management software now reports Predictive Failure Analysis (PFA) flags on drives.
- **Firmware autosynch.** If you replace a controller with firmware level 3.00.X or higher, the firmware on the new controller automatically synchronizes with the firmware on the remaining controller.

Note – The controller autosynch feature requires the setting of two NVSRAM bits for it to work. At the time this manual was published, this feature was not supported by Sun.

- **Fibre Channel Loop ID.** A new `nvutil` option enables you to set the controller's Fibre Channel Loop ID.
- **Backup Log redirection.** You can now set the location for your old log file when the threshold limit is reached.
- **Parity Check/Repair Enhancement.** You may now choose not to repair errors during parity check/repair.

Other Features

The storage management software also supports these new features:

- **Dynamic Expansion Capabilities.** The Modify Group/LUN feature in the Configuration Application enables you to change the RAID Level of existing LUNs, add more capacity to drive groups, defragment data storage space, and change LUN segment size.

Note – The dynamic expansion options require controller firmware level 3.01.02.xx or higher.

- **Performance Monitor.** This feature in the Status Application enables you to monitor I/O activity on selected controllers and LUNs for a selected RAID Module while it is in use. This monitoring allows you to gather useful information for evaluating system performance and determining possible methods for improvement.
- Module Profile support for Fibre Channel host connections.
- Weekly auto parity check.
- Additional failure types detected and appropriate recovery procedures added in the Recovery Guru.
- Support for two additional configurations: independent controller and multi-host. See the *Sun Storage RAID Manager User's Guide* for more details on supported configurations.
- RAID Module selection enhancements (included in the Select Module option):
 - Provide a user-supplied name to a RAID Module and also provide comments for easier identification.
 - Easily remove a RAID Module and its association to the storage management software.
 - RAID Module selection window enables you to select a RAID Module before you enter an application.
 - Find feature to easily select a RAID Module from a list.
- Additional battery management functions are provided by the `raidutil` utility. (For more information, read the `raidutil` man page.)
- Enhancements to caching features:
 - An operating status of the cache parameter is now displayed in the caching parameters option and in Module Profile → LUNs to let you know when write caching has been enabled but is currently not active.
 - Module Profile → Controllers now includes the microprocessor cache size of the controller.

About the Installation Procedure

Start the installation procedure with the next section in this chapter, “Understanding the Restrictions” on page 6.

Note – Before you attempt to install the RAID Manager software, be sure to read the *Sun StorEdge RAID Manager Release Notes* for the latest installation and operation procedures.

- Continue with each section, step by step, for the installation procedure you are performing, through the end of Chapter 3, “Initial Startup.”
- If you are upgrading from a previous version of storage management software, you can stop the installation procedure after completing the tasks in “Completing the Installation” on page 51.

After you have completed the installation procedure:

- You may need to go to Chapter 4, “Customizing the Installation” to add or modify features in the storage management software. However, you do not need to customize the installation to run the software.
- You also may want to review the material in Chapter 5, “Operating Environment Support” to learn more about how the storage management software operates in the Solaris environment.

After you have completed all installation and customizing tasks in this book:

- Refer to the *Sun StorEdge RAID Manager User's Guide* for complete information on how to operate the storage management software.
- You may need to refer back to Chapter 5, “Operating Environment Support” from time to time for features unique to the Solaris operating environment.

Understanding the Restrictions

[Table 1-1](#) identifies the known restrictions for using this software in the Solaris operating environment. In some cases, there are notes for working around the restrictions. For more detailed information on troubleshooting the installation, see [Chapter 6](#) of this guide.

Note – Always check for a README file on any installation media and the *Sun StorEdge RAID Manager Release Notes*. They may contain important information that was not available at the time this *Installation and Support Guide* was prepared.

TABLE 1-1 Restrictions for the Solaris Operating Environment (*1 of 3*)

Restriction	Application	Workaround
RDAC failover does not work during system dump if the dump/swap device is a RAID Module LUN different from the LUN used for the boot device.	Installation and Setup	Do not create a RAID Module LUN having only dump/swap areas. It is acceptable to put the dump/swap area on the same LUN as the boot device.
When adding a RAID Module with the same name as an existing module, the name of the existing module changes.	Installation and Setup	The new module name is the old module name with a revision number appended (for example, <i>module_name</i> becomes <i>module_name2</i>). Either use unique module names or change the names after adding the new module. Note that any existing scripts or applications that depend on the existing module name must be modified.
During installation, the system may hang for several minutes. A “No such device or address” message may be displayed on the console.	Installation and Setup	Wait several minutes for the operation to be completed.
Do <i>not</i> use A3000 controllers with 2.04.X or 2.05.04 controller firmware as replacements in a module running 3.01.X firmware. In SCSI systems, use replacements with a minimum firmware level of 2.05.06. In Fibre Channel systems, use replacements with a minimum firmware level of 3.00.X.	General	None. If you are not certain what firmware version a spare controller has, do <i>not</i> use it. Obtain spare controllers (with the minimum firmware required) from your local solution center.

TABLE 1-1 Restrictions for the Solaris Operating Environment (2 of 3)

Restriction	Application	Workaround
Redundant controllers must have the same cache size. Mis-matched cache sizes on controllers acting as a redundant pair can result in operation errors and possible data corruption.	General	None.
On some systems, the storage management software can only support multi-initiator configurations with Sun™ Cluster software.	General	Refer to the <i>Sun Cluster Software Planning and Installation Guide</i> , or check with your Sun service provider, for multi-initiator issues.
The command line <code>raidutil</code> utility does not always generate an error message, even when an operation fails. For example, using <code>raidutil -R</code> to reset the controller battery age without LUN 0 created causes the operation to fail. However, there is no error message.	General	Anytime you use the <code>raidutil</code> utility to perform an operation, it is a good idea to verify that it completed successfully. For example, after creating LUNs, you might want to use the command-line utility <code>lad</code> to verify your configuration.
The amount of time it takes to perform operations may increase as the number of configured LUNs increases. For example, changing caching parameters can take up to 30 seconds per LUN and up to 15 minutes if changing 32 LUNs. Also, large cache sizes could increase the time.	General	None.
If you are using a SUN host adapter and a cable disconnects, storage management software applications may hang, especially if you are using Sun Enterprise Volume Manager™.	General	Reboot the host system.
Do not reset the SCSI bus or turn a module off and then on again if the module contains Dead LUNs.	General	None. If you reset the SCSI bus, or turn off a module and turn it on again, the LUNs are lost and you must use the Configuration application to recreate them.
The storage management software may be unresponsive if you power down a RAID Module.	General	Make sure the storage management software is closed before powering down a RAID Module.
Version checking is not performed if the only file to download is the bootware file.	Maintenance and Tuning	When upgrading controller firmware, always download both the <code>appware</code> file and the <code>bootware</code> file.

TABLE 1-1 Restrictions for the Solaris Operating Environment (3 of 3)

Restriction	Application	Workaround
<p>The system may lock up when a controller that has been offline is brought back online during heavy I/O activity.</p>	<p>Recovery</p>	<p>Bring the controller back online when there is little I/O activity.</p>
<p>Using Recovery operations to revive or fail an actual bad drive may result in the RAID Controller not being reported. This also occurs if you replace a failed Hot Spare drive with a bad drive. A series of time-outs in the RAID Controller, the storage management software, and the SCSI host adapter driver eventually cause the host to stop retries. As a result, all SCSI operations to the controller fail until you reboot the host.</p>	<p>Recovery</p>	<p>Reboot if a controller disappears after a drive replacement or revival. For detailed information on the Manual Recovery Options in the Recovery application, see Chapter 6 of this guide.</p>
<p>When a drive failure causes a RAID 0 Dead LUN, using Recovery Guru to format the LUN will cause a system panic.</p>	<p>Recovery</p>	<ol style="list-style-type: none"> 1. Perform the directed Recovery Guru actions up to and including replacement of the failed drive. 2. When the Guru asks for confirmation of the LUN format operation, close all storage management applications and reboot the Solaris host. 3. When the reboot is complete, restart the storage management software and use Options → Manual Recovery → Logical Units and Format the affected LUNs.
<p>When you replace a failed drive, this software allows 35 seconds for the controller to initialize the new drive. However, if you have a controller and are in a Dead LUN situation (single Drive Failure for RAID 0 or Multiple Drive Failure for RAID 1, 3, or 5), Recovery Guru does not perform a format on the LUNs. If you do not manually format the LUNs, subsequent file system mounts will fail.</p>	<p>Recovery, Recovery Guru</p>	<ol style="list-style-type: none"> 1. After inserting the replacement drive, wait for the drive's activity light to go off before clicking OK (that is, wait for more than 35 seconds). 2. If you do not wait and you see the "LUN is still Dead due to remaining drive failures" message, you need to use Options → Manual Recovery → Logical Units and Format the affected LUNs. 3. If the affected LUNs had file systems that failed to mount, use the <code>newfs</code> command to create a new file system.

Continue with the next section "Hardware and Software Requirements" .

Hardware and Software Requirements

Before installing the storage management software, make sure that you have all of the hardware and software components installed.

- Hardware Configuration—page 9
- Operating Environment—page 10
- Host Adapters, Hubs, and Switches—page 11
- Checking the Hardware—page 11

Hardware Configuration

The following hardware is required:

- A graphics card with a minimum 800 x 600 resolution.
- A mouse or similar pointing device.
- RAID modules with two A3x00 controllers.
- A minimum controller firmware version depending on the controller model.

See Table A-4 on page 121 for a list of supported firmware levels.

Note – You can install Sun StorEdge RAID Manager with firmware versions before 2.5.2; however, you must immediately upgrade the firmware to version 2.5.2 or later *after* you have completed the installation. In some cases, it may be necessary to upgrade to an intermediate firmware level *before* upgrading to a later firmware level. Refer to “Verifying and Upgrading Controller Firmware” on page 44 for instructions on determining the current firmware level and downloading controller firmware.

- One or two host machines with a Host-RAID Module configuration supported by the software. See “Host-RAID Module Configurations” on page 116 for information on supported configurations.

See Table A-1 on page 117 for a list of platforms currently supported for the Sun StorEdge A3x00 and A3500FC systems.

Note – Unless the A3000 or A3500 is uniquely identified, both types of systems are referred to as “A3x00” throughout this document.

Operating Environment

The Solaris 2.6 or Solaris 7 operating environment must be installed on *one* of the following:

- The host machines connected by a SCSI or Fibre Channel cable to the RAID Modules, *or*
- LUN 0 of a RAID Module *if* you want to use the module as a boot device. This involves preparing the host system to boot from the RAID Module and installing all software.

You can use *one* of the following commands to obtain version information about your Solaris operating environment.

- Type the following at the system prompt:

```
uname -a
```

The version is specified as 5.6 (for Solaris 2.6 software) or 5.7 (for Solaris 7 software).

- Type the following at the system prompt:

```
cat /etc/release
```

The `/etc/release` file includes version information as shown in the following example.

```
Solaris 2.6 5/98 s297s_hw3smccServer_09 SPARC
Copyright 1998 Sun Microsystems, Inc. All Rights Reserved.
Assembled on 24 April 1998
```

If the `/etc/release` file does not exist, your system may be running a version earlier than Solaris 2.6 5/98.

Host Adapters, Hubs, and Switches

See “Hardware Specifications” on page 116 for information on the host adapters, hubs, and switches tested with the storage management software.

Checking the Hardware

Use the following checklist to make sure that the RAID Modules have been correctly connected to the host system. If necessary, refer to the documentation supplied with the RAID Module:

- Cable connections are correct and secure?
- Termination are correct and secure?
- Host-side IDs are set properly?

Each controller in each RAID Module must have a unique host-side ID (that is, no two devices on the same SCSI Bus or Fibre Channel loop can have the same host-side ID).

Note – For the greatest level of I/O path protection, provide each controller in a RAID Module with its own data path connection (that is, cable and host adapter) into the host system.

If the host system is networked, see “SNMP Notification” on page 14 to set up and enable the SNMP option.

Configuring the Solaris Environment to Support Sun StorEdge RAID Manager

TABLE 1-2 summarizes the changes you need to make to fully support Sun StorEdge RAID Manager with the Solaris operating environment.

TABLE 1-2 Required Changes for Solaris Operating Environment

Task To Perform	Purpose	For More Details, Go To
Install patches to support Sun StorEdge RAID Manager.	To ensure proper operation of Sun StorEdge RAID Manager with the Solaris operating environment	“Patches Required to Support the Solaris Operating Environment” on page 12
Edit the <code>rmparms</code> file.	To increase LUN support per host adapter and/or enable SNMP notification	“The <code>rmparms</code> File” on page 13
Edit the <code>rmscript</code> file.	To set up scriptable event notifications (such as third-party vendor’s paging, Fax, and so on)	“Setting Up Other Scriptable Notification Options” on page 14
Set the SNMP notification.	To enable or disable this remote notification option	“SNMP Notification” on page 14

Patches Required to Support the Solaris Operating Environment

Software patches are available to ensure proper operation of the RAID Manager software in the Solaris operating environment. Make sure that all required patches are installed properly *before* installing the Sun StorEdge RAID Manager software.

Refer to the *Sun StorEdge RAID Manager Release Notes* (805-7758-xx) for a list of patches (including patch ID numbers) required to use the Sun StorEdge RAID Manager software in your Solaris operating environment.

The `rmparams` File

The `rmparams` file is used to store several configurable options available through Sun StorEdge RAID Manager. You need to change options in this file if you:

- Want to increase the number of controllers allowed on the system.
- Want to support more than eight LUNs on your RAID modules (see [“Setting the Logical Unit Limit” on page 36](#)).
- Want to enable/disable SNMP notification.
- Are upgrading the storage management software and want to make customized changes to this file. Use the original `rmparams` file that you saved to determine the changes you want to make. Remember, the new file contains new parameters for this version, so do *not* replace it with the old file.
- Are installing this software for the first time and want to review the changes you can make.

For more information about the `rmparams` file and how to change the options in this file, see:

- [“Changing the `rmparams` File” on page 66](#).
- [“`rmparams` File Listing” on page 124](#).
- the `rmparams` man page for a description of the format this file uses.

Setting Up Other Scriptable Notification Options

You can edit the `rmscript` file. For example, if you want to install third-party notification software to perform various events (such as faxing or paging), you would add the appropriate script for each event near the end of this file. Consult the third-party's software documentation for specific details.

For more information in this guide about the `rmscript` file and how to set up other scriptable notification options, see:

- “Setting Up Scriptable Notification Options” on page 70.
- “`rmscript` File Listing” in Appendix B for the file's contents.
- the `rmscript` man page for a description of the format this file uses.

SNMP Notification

Using Simple Network Management Protocol (SNMP) traps, the Sun StorEdge RAID Manager software can provide remote notification of RAID events to designated network management stations (NMS).

To enable SNMP notification on your host, you must edit the `/etc/raid/rmparams` file so that the software will know where to direct the SNMP trap messages when a RAID event has occurred. For instructions on editing the `rmparams` file, see “Changing the `rmparams` File” on page 66.

For detailed information about enabling or disabling SNMP, see “Setting Up SNMP Notification” on page 72.

Installing the Software on a Standard Configuration

This chapter leads you through the steps for installing or upgrading the storage management software on a single host, multi-host, or independent controller configuration:

- Selecting the Appropriate Installation Procedure—page 16
- Upgrading to Sun StorEdge RAID Manager 6.22—page 17
- Installing the Sun StorEdge RAID Manager Software—page 20
- Removing an Earlier Version of Sun StorEdge RAID Manager—page 32
- Deinstalling RAID Manager—page 33

Before you install the storage management software on your system, make sure you do the following:

- Read the *Sun StorEdge A3500/A3500FC Hardware Configuration Guide* (805-4981-xx).
- Prepare the host system by installing the appropriate host adapter cards for SCSI or Fibre Channel-Arbitrated Loop (FC-AL) connections. Refer to the documentation that came with your host adapter and A3500/A3500FC system for instructions.
- Install the Sun StorEdge A3500/A3500FC system and connect it to the host as described in the *Sun StorEdge A3500/A3500FC Controller Module Guide* (805-4980-xx).

Selecting the Appropriate Installation Procedure

The procedure you use to install the storage management software depends on whether you are upgrading a previously installed version or installing the software for the first time.

Upgrade?	First-Time Installation?
Continue with “Upgrading to Sun StorEdge RAID Manager 6.22” on page 17.	Go to “Installing the Sun StorEdge RAID Manager Software” on page 20.

Upgrading to Sun StorEdge RAID Manager 6.22

Before you attempt to upgrade your current version of RAID Manager, read the following notes.

- Do not add or remove any new peripherals or devices to/from your system until you have completed upgrading to the latest version of RAID Manager software.
- Be sure to save a copy of the `/etc/osa/rmparams` file and the `/usr/lib/osa/bin/rmscript` file *before* starting the upgrade procedure. You can refer to these files after the upgrade and decide if you need to customize the new files with any changes you may have made. Do *not* copy the old files over the new files. This action will destroy new parameters and scripts that were installed with the latest version of Sun StorEdge RAID Manager software.
- If you are upgrading from Sun StorEdge RAID Manager 6.0, the RAID module numbers/names will change. In the newer versions of the software the module name is derived from the host machine where the Sun StorEdge RAID Manager software is installed. With Sun StorEdge RAID Manager 6.0 the modules were labeled “RAID Module XX.” The newer versions label the modules “<hostname>_XXX.” For example, if the host machine running the storage management software is named “hobo”, the RAID module names will be “hobo_XXX.”
- If you are upgrading from Sun StorEdge RAID Manager 6.0 or 6.1, LUNs created in these environments will not be able to use the new dynamic drive group/LUN features included in Sun StorEdge RAID Manager 6.22. In order to use the new features, you must first delete and recreate any LUNs created in earlier versions of RAID Manager.
- Refer to the *Sun StorEdge RAID Manager Release Notes (805-7758)* for information about preserving the device names of LUNs that have valid data; see Bug ID 4118532 in the section that discusses “Known Issues.”

Requirements

To complete this upgrade procedure, you need:

- Sun StorEdge RAID Manager 6.22 CD
- The appropriate patches (if any) for your configuration

▼ To Upgrade to RAID Manager 6.22

1. **Repair any hardware failures on the A3x00 arrays.**
2. **Prepare any layered volume management applications for upgrade.**
 - For Solstice DiskSuite, see the *Solstice DiskSuite 4.1 Reference Guide* (802-6724).
 - For Volume Manager, see the *Sun StorEdge Volume Manager 2.6 Installation Guide* (805-5707).
3. **Prepare for upgrading to the latest version of Sun StorEdge RAID Manager software.**
 - a. **Save a copy of the current `/kernel/drv/sd.conf` file.**
 - b. **Save a copy of the current `/etc/path_to_inst` file.**
 - c. **Save a copy of the current configuration:**
 - i. **From any application, select File → Save Module Profile.**
 - ii. **Make sure all information is selected, and select OK.**
 - iii. **Save to a location that is separate from the storage management software to ensure it will not be removed during the software removal procedure.**
 - iv. **Preserve the device names of LUNs that have valid data; see the description for Bug ID 4118532 in the *Sun StorEdge RAID Manager Release Notes* (805-7758) under “Known Issues.”**
4. **Exit the Sun StorEdge RAID Manager software.**

Make sure an earlier version of Sun StorEdge RAID Manager software is not currently open or running.
5. **Unmount any file systems and stop any I/O to the RAID modules connected to the host on which the Sun StorEdge RAID Manager software is being upgraded.**
6. **Remove the earlier version of RAID Manager from your system.**

Go to “Removing an Earlier Version of Sun StorEdge RAID Manager” on page 32.
7. **If you want to upgrade your Solaris operating environment, go to Step 8. Otherwise, skip Step 8 and go to Step 9**
8. **Install your new Solaris operating environment (optional).**

Refer to your *SPARC: Installing Solaris Software* and *SPARC: Hardware Platform Guide* for more information on upgrading Solaris. Return to this document to continue with the upgrade to Sun StorEdge RAID Manager 6.22 software.
9. **Install all required patches as outlined in the *Sun StorEdge RAID Manager Release Notes* (805-7758-xx).**

It is important that you apply the latest device driver patches to your Solaris operating environment *before* downloading any RAID controller firmware or executing any hardware patches. This step is required to ensure that no problems arise while executing the hardware patches on your current system. A reboot of the current operating environment is required to load and initialize the newly patched device drivers.

10. **Install the Sun StorEdge RAID Manager 6.22 software; refer to “Installing the Sun StorEdge RAID Manager Software” on page 20.**
11. **Verify installation of the software; refer to “To Verify the Installation” on page 30.**
12. **Re-install layered volume management applications as described in the Installation Guide for each application (see Step 2 above).**

Caution – If the Sun Storage Volume Manager 2.6 software is installed on your system, a default feature known as Dynamic Multi-Pathing (DMP) is *active* by default. The Sun StorEdge RAID Manager software and the A3x00 RAID array do not support DMP. Redundant I/O pathing is maintained internally by the Sun StorEdge RAID Manager software. Therefore, you must disable the DMP feature in Volume Manager and reboot the system.

Refer to the *Sun StorEdge Volume Manager 2.6 Release Notes* (805-5708) and the *Sun StorEdge Volume Manager 2.6 System Administrator's Guide* (805-5706) for detailed information about disabling the DMP feature in Volume Manager.

Installing the Sun StorEdge RAID Manager Software



Caution – Be sure all hardware is connected to your host system *before* installing the software. Failure to do so could result in the storage management software not recognizing the RAID Modules.

▼ To Mount the CD-ROM

Note – Depending on how your workstation is configured, your CD-ROM drive may be mounted automatically. If the CD-ROM drive is *not* mounted, you *must* mount it *before* you can install the software.

1. Is the CD-ROM mounted?

Yes? Continue with Step 4.

No? Continue with Step 2.

2. If no mount point directory exists, create one.

3. Mount the CD-ROM drive by typing:

```
# mount -F hsfs -o ro /dev/dsk/cXtXdXsX /cdrom
```

Where *cXtXdXsX* is the device node of the CD-ROM (for example, *c0t6d0s0*) and */cdrom* is the mount point.

4. Load the disc with the label side facing up into the CD-ROM drive.

5. Continue with “Sun StorEdge RAID Manager Installation Options.”

Sun StorEdge RAID Manager Installation Options

There are two methods (`swmtool` and `pkgadd`) that can be used to install the Sun StorEdge RAID Manager software. The `swmtool` process provides a graphical user interface (GUI) that simplifies the task of installing the Sun StorEdge RAID Manager software package clusters. `pkgadd` is the standard command line interface installation process. Refer to TABLE 2-1 for package descriptions.

After mounting the CD-ROM drive, you can use one of the following methods to install the software for use with the Solaris operating environment.

`swmtool`

The `swmtool` (Software Manager) utility is the recommended method to use when installing software package clusters from the software CD. To use `swmtool`, you must install the X Window system on your system and run OpenWindows™. For instructions on using `swmtool`, refer to “To Install RAID Manager Using `swmtool`” on page 22.

Note – `swmtool` is the installation method described throughout this chapter (unless otherwise noted). Instructions on how to use the `pkgadd` utility are also provided if you prefer this method of installation.

`pkgadd`

The `pkgadd` utility is another method used to install software package clusters from the software CD. `pkgadd` differs from `swmtool` in that you do not need to run OpenWindows; you can invoke the `pkgadd` command at the system prompt. For instructions on using `pkgadd`, refer to “To Install RAID Manager Using `pkgadd`” on page 25.

TABLE 2-1 Package Descriptions

Cluster Name	Description
SUNWosafw	Open Storage Array (firmware)
SUNWosar	Open Storage Array (root)
SUNWosau	Open Storage Array (usr)
SUNWosamn	Open Storage Array (man pages)

▼ To Install RAID Manager Using `swmtool`

Before you begin this procedure, do the following:

- Install any software patches that may be required for your Solaris environment. Refer to the *Sun StorEdge RAID Manager Release Notes* for patch ID numbers.
- Make sure the installation media device you are using is attached to your system when you boot the system.



Caution – This installation procedure requires you to reboot your system. Therefore, make sure that other users are not on the system when installing this software.

1. **Start the OpenWindows environment.**
2. **Load the Sun StorEdge RAID Manager CD into your CD-ROM drive with the label side facing up.**
If there is another CD in the drive, remove it by typing `eject` in a shell window.
3. **Open File Manager.**
4. **Open a command window and (if you are not already `superuser`) become `superuser` using the `su` command and `superuser` password.**
5. **Start Software Manager by typing:**

```
# /usr/sbin/swmtool
```

Admintool: Software is displayed.

6. **Select Edit... Add.**
The Set Source Media window is displayed.
7. **Select Mounted Directory if you are running Volume Management or Local CD-ROM as your media type.**
8. **Type the path to the source media in the Directory Name:**

```
# /cdrom/cdrom0
```

The Software Manager window is displayed with the Sun StorEdge RAID Manager packages to be installed.

9. Click on the Open Storage Array packages to be installed.

Click on Customize if you need to change the Sun StorEdge RAID Manager packages.

10. Click the Add button.

The Software Manager: Command Input/Output window is displayed with pre-installation information followed by this prompt:

```
Do you want to continue with this installation?
```

11. Respond with <y> (yes).

Installation messages are displayed in the Software Manager: Command Input/Output window.

It may take one to two minutes before you notice certain tasks occurring (see TABLE 2-2).

The following message is displayed after the installation process has been completed:

```
Installation of SUNWxxxx was successful.
```

where *SUNWxxxx* is the specific package name.

12. Quit the Software Manager program.



Caution – Install the software patches for your Solaris environment if you have not done so already. Failure to do so may cause your system to boot improperly. Refer to the patch information in the *Sun StorEdge RAID Manager Release Notes*.

13. Shut down the system by typing:

```
# shutdown -y -i0 -g1
```

See the `shutdown(1M)` man page for more information. Using the `shutdown` command is more efficient than using the `halt` command.



Caution – Make sure that you use the `boot -r` option for the reboot required in Step 14 and in future reboots following any changes in RAID configuration. This option ensures that the system is reconfigured according to your changes.

14. Reboot the system by typing:

```
ok> boot -r
```

Several additional tasks are performed as the system reboots. You may notice some of these shown in TABLE 2-3.

15. When a message appears (The system is ready) on your screen, do you see the NVSRAM settings are correct message?

No	Yes
Continue with Step 16.	Continue with “To Verify the Installation” on page 30.

16. If the NVSRAM message says that settings were changed, turn off the power to the RAID module controllers and then on again to implement the new NVSRAM settings.

On SCSI RAID Modules, you can reboot the system again by typing:

```
# shutdown -y -i0 -g1
ok> boot
```

After the system reboots, continue with “To Verify the Installation” on page 30.

▼ To Install RAID Manager Using `pkgadd`

Before you begin this procedure, do the following:

- Install any software patches that may be required for your Solaris environment. Refer to the *Sun StorEdge RAID Manager Release Notes* for patch ID numbers.
- Make sure the installation media device you are using is attached to your system when you boot the system.



Caution – This installation procedure requires you to reboot your system. Therefore, make sure that other users are not on the system when installing this software.

1. **Load the Sun StorEdge RAID Manager CD into your CD-ROM drive with the label side facing up.**

If there is another CD in the drive, remove it by typing `eject` in a shell tool window.

2. **Become superuser by using the `su` command and entering your superuser password.**
3. **Type:**

```
# /usr/sbin/pkgadd -d /cdrom/cdrom0/Product package_name
```

Note – The argument to the `-d` option must be a full path name to a device or directory. If you do not specify the device on which the package resides, `pkgadd` checks the default spool directory (`/var/spool/pkg`). If the package is not there, the installation fails.

A list of all packages on the CD is displayed, including the storage management software and all firmware packages.

4. **Select `all` to download all packages on the CD.**

To install Sun StorEdge RAID Manager, choose the packages in the following order:

1. `SUNWosar`
2. `SUNWosafw`
3. `SUNWosamn`
4. `SUNWosau`

5. Follow the instructions on the screen to install the packages provided on the CD-ROM.

You may see a message that the installation process includes certain scripts with super-user privileges.

6. During installation, information is displayed and followed by this prompt:

```
Do you want to continue with this installation?
```

7. Respond with <y> (yes).

It may take one to two minutes before you notice certain tasks occurring (see TABLE 2-2). The README file is now available for your review.

TABLE 2-2 Tasks Performed During Installation

What You Will See	Automatic Task Occurring	Why Is the Task Being Done?
Installing RAID Manager as <rm6> and a listing of directories and files being copied.	Files are copied to the host system.	All of the files are being copied to the appropriate directories.
Installing man pages	Reference man pages are copied to the host system.	man pages associated with Sun StorEdge RAID Manager are being copied to the appropriate directory.
kernel/drv/sd.conf already exists. OK to modify?	sd.conf file is updated.	This file is used to specify the logical unit (LUN) support for the operating system, but initially has only LUN 0 defined for each SCSI ID. Therefore, this file is edited to add multiple LUN support (0-7) for each controller in each RAID Module connected to the host system.
Adding RAID Manager changes to /etc/syslog.conf	syslog.conf file is updated.	Sun StorEdge RAID Manager logs certain failure messages from the arraymon daemon and the graphical user interface (GUI) applications to the syslogd daemon. This file is edited to ensure that Solaris consistently logs these messages to this file.
RAID Manager README file /etc/raid/README	The README file is displayed.	The README file provides important information about the software.

8. When you finish reviewing the README file, quit pkgadd.

You see a message indicating whether or not you need to reboot the system. In either case, you can remove the installation CD by typing:

```
# eject cdrom
```



Caution – Install the software patches for your Solaris environment if you have not done so already. Failure to do so may cause your system to start up improperly. Refer to the *Sun StorEdge RAID Manager Release Notes (805-7758)* for a list of required patches.

9. Did the message tell you that you need to reboot the system?

If No?

Go to “To Verify the Installation” on page 30.

If Yes?

Continue with Step 10.

10. Shut down the system by typing:

```
# shutdown -y -i0 -g1
```

Refer to the `shutdown(1M)` man page for more information, if needed. Using the `shutdown` command is preferred over the `halt` command.



Caution – Make sure that you use the `boot -r` option for the reboot required in Step 11 and in future reboots following any changes in RAID configuration. This option ensures that the system is reconfigured according to your changes.

11. Reboot the system by typing:

```
ok> boot -r
```

Several additional tasks are performed as the system reboots. TABLE 2-3 shows some of the tasks you may see occurring.

TABLE 2-3 Tasks Performed During System Reboot

What You Will See	Automatic Task Occurring	Why Is the Task Being Done?
<pre>"Setting up RAID device access..." "Re-generating rdriver.conf file..."</pre>	<p>The software is setting up the correct device nodes for Redundant Disk Array Controller (RDAC) support.</p>	<p>To ensure the software device access.</p>
<pre>"RDAC Driver re-loaded..."</pre>	<p>The RDAC Driver is loaded.</p>	<p>The RDAC Driver provides failover support for data connections. (For a description of RDAC and the protection it provides, see “Command-Line Interface” on page 86.)</p>
<p>Example if NO changes were made:</p> <pre>"The NVRAM settings of controller cXtXdX (1TXXXXXXX) are correct. nvutil command succeeded."</pre> <p>Example if changes were made:</p> <pre>"The NVRAM value of Unconfigured LUNs bit field of controller cXtXdX (1TXXXXXXX) at offset 0x11 is invalid, the value is 0x20 (the valid value should be 0x0). The incorrect NVRAM settings of controller cXtXdX (1TXXXXXXX) have been fixed. Reboot the system for the new settings to take effect. nvutil command succeeded"</pre> <p>Note: If you have trouble getting the software to recognize the RAID Modules, review “NVRAM Settings” on page 123.</p>	<p>NVRAM settings on the controller(s) in the RAID Module being checked and, if necessary, corrected by the nvutil program.</p>	<p>Certain configuration settings must be set so that the software can communicate correctly with the controllers in the RAID Module.</p> <p>Note: If you have trouble getting the software to recognize the RAID Modules, review the nvutil man page.</p>

TABLE 2-3 Tasks Performed During System Reboot (Continued)

What You Will See	Automatic Task Occurring	Why Is the Task Being Done?
"Array monitor initiated..."	The monitor daemon (arraymon) is started.	The array monitor daemon (arraymon) automatically checks the RAID Module(s) for any problems/events and provides appropriate notification.
"RDAC Daemons Initiated..."	The RDAC daemons are started.	The RDAC daemons provide fail-over support for the I/O data connections.
"RDAC Resolution Daemon locked in memory..."	RDAC is set up to resolve errors.	If errors occur, RDAC can resolve them.

12. When a message appears (The system is ready) on your screen, do you see the NVSRAM settings are correct message?

No	Yes
Continue with Step 13.	Continue with "To Verify the Installation" on page 30.

13. If the NVSRAM message says that settings were changed, turn off the power to the RAID module controllers and then on again to implement the new NVSRAM settings.

On SCSI RAID Modules, you can reboot the system again by typing:

```
# shutdown -y -i0 -g1
ok> boot
```

After the system reboots, continue with "To Verify the Installation" on page 30.

▼ To Verify the Installation

1. At the command line, type:

```
pkginfo -l package_name
```

A list showing statistics (version information, installation date, file information, and so on) about the software appears. The status field reads “completely installed” if the installation was successful.

2. At the command line type:

```
ps -ef | grep arraymon
```

A confirmation line shows the array monitor (arraymon) as an active process, for example:

```
root 1724      1 0   Aug 02 ?           0:14 /usr/lib/osa/bin/arraymon
root 5520     5512 0 16:31:18 pts/6   0:00 grep arraymon
```

3. At the command line type:

```
ps -ef | grep rdaemon
```

A confirmation line shows the rdac resolution/restart daemons as two active processes, for example:

```
root 1764    1745 0   Aug 02 ?           0:00 /usr/lib/osa/bin/rdaemon 29 156 5
root 1745      1 0   Aug 02 ?           0:00 /usr/lib/osa/bin/rdaemon 29 156 5
root 5522     5512 0 16:31:40 pts/6   0:00 grep rdaemon
```

4. Is the confirmation line displayed?

No	Yes
Continue with Step 5.	Go to Chapter 3, "Initial Startup".

5. If the previous steps are unsuccessful, do the following:

a. Shut down the system by typing:

```
shutdown -y -i0 -g1
```

b. Reboot the system by typing:

```
boot -r
```

c. Repeat Steps 1-3.

d. If you still have problems, uninstall Sun StorEdge RAID Manager and then reinstall it.

When you have successfully installed the storage management software, go to [Chapter 3, "Initial Startup."](#)

Removing an Earlier Version of Sun StorEdge RAID Manager

If you need to remove Sun StorEdge RAID Manager (for example, to re-install the software if there is some problem during the installation procedure), use the `pkgrm(1)` utility. Based on the current version of RAID Manager software installed on your system, remove the packages in the order they are listed in TABLE 2-4.

TABLE 2-4 Removing Earlier Versions of Sun StorEdge RAID Manager

RAID Manager Version	Remove These Packages
6.0	SUNWosau SUNWosar SUNWosaab SUNWosamn
6.1	SUNWosau SUNWosar SUNWosaab SUNWosahb SUNWosaib SUNWosamn SUNWosafw
6.1.1/6.1.1 Update 1/6.1.1 Update 2	SUNWosau SUNWosar SUNWvtsse SUNWosamn SUNWosafw

Note – Certain critical files remain after you remove the packages. Be sure to keep these files in order to make any system changes to the new version of storage management software.

The `rmlog.log` file also remains after using `pkgrm` to remove the software. Although keeping this file should not cause any problems, you may want to manually delete it.

1. Type the following command to remove each package listed above for your current version of Sun StorEdge RAID Manager software:

```
pkgrm package_name
```

2. Follow the instructions on the screen to remove each package.

Deinstalling RAID Manager

If you need to deinstall the RAID Manager software, use the `pkgrm(1)` utility and follow the instructions on the screen.

The `rmlog.log` file also remains after using the `pkgrm` utility to deinstall the software. Although keeping this file should not cause any problems, you may want to manually delete it.

Note – You cannot use `pkgrm` on the RAID Manager software if the RAID module is the boot device.

Initial Startup

This chapter contains procedures for operating the Sun StorEdge RAID Manager software and determining if the system configuration meets your needs.

- Setting the Logical Unit Limit—page 36
- Setting the Controller's Fibre Channel Loop ID—page 38
- Starting the Software—page 40
- Setting Up Independent Controllers—page 42
- Assigning Names to the Modules—page 43
- Verifying and Upgrading Controller Firmware—page 44
- Running Recovery Guru/Health Check—page 48
- Completing the Installation—page 51
- Determining the Current Configuration—page 52
- Determining If Any Changes Are Necessary—page 58
- Configuring RAID Modules—page 63
- What's Next?—page 64

Setting the Logical Unit Limit

Each host adapter used with the storage management software has a maximum number of LUNs it can support. This limit depends on the operating environment version and installed patches.

By default, the storage management software limits all host adapters to eight LUNs (whether the module has a single controller or redundant controllers—therefore, if you have a RAID module with two active controllers, the total number of LUNs between them *cannot* be more than eight). You must make changes to your software if your configuration allows more than eight LUNs per host adapter.

Refer to the *Sun StorEdge RAID Manager Release Notes (805-7758-xx)* for detailed information about the number of LUNs per RAID module that are supported for the various combinations of host connection, host adapter, Solaris operating environment version, and patch level.

Note – For best results, configure all 32 LUNs on your RAID modules if you make changes to support 32 LUNS. If you do not have all the LUNs configured, you may notice system delays at start-of-day.

Setting the LUN Limit in the `rmparams` File

You should change the `System_MaxLUNsPerController` parameter in the `/etc/osa/rmparams` file if *any* of your host adapters support 32 LUNs.

The following procedure applies only to the host adapters listed in TABLE 1 and TABLE 2.

TABLE 1 SCSI Host Adapters

Type of Host Adapter	Product Description	Part Number
Sbus	Differential Fast-Wide Intelligent SCSI-2 (DWIS)	X1062A
Sbus	Ultra Differential Fast-Wide SCSI (UDWIS)	X1065A

Note – Refer to the *Sun Storage RAID Manager Release Notes* for information about the Dual-Channel UltraSCSI Host Adapter PCI (part number X6541A).

TABLE 2 Fibre Channel Host Adapters

Type of Host Adapter	Product Description	Part Number
Sbus	Sun StorEdge Sbus FC-100 Host Adapter	X6730A
PCI	Sun StorEdge PCI FC-100 Host Adapter	X6729A

Caution: Do not use the Sbus HBA card with a part number of 501-3060.

1. Using any text editor, open the `/etc/osa/rmparams` file. (See “Changing the `rmparams` File” on page 66.)
2. Change the `System_MaxLunsPerController` parameter to 32.
3. Save the `rmparams` file, and back it up to the `/usr/lib/osa` directory.

Note – When you installed this software, a copy of the `rmparams` file named `rmparams.install` was saved to the `/usr/lib/osa` directory. If necessary, you can use this file to return to your installation settings.

Anytime you make changes to the `rmparams` file, save a copy of the new file to the `/usr/lib/osa/rmparams.save` directory. If the `/etc/osa/rmparams` file is corrupted or lost, you can resume normal operation by copying the backup file to `/etc/osa/rmparams`.

4. Run the following script:

```
/usr/lib/osa/bin/genscsiconf
```

This adds 32 LUN support for targets 4 - 5 to the `/kernel/drv/rdriver.conf` file and/or to the `/kernel/drv/sd.conf` file, depending on the type of host connection and on the `rmparams` settings you have entered.

5. Shut down and reboot the Solaris operating environment by typing:

```
# shutdown -y -i0 -g0
ok> boot -r
```

6. If you are using a Fibre Channel configuration, continue with the next section, “Setting the Controller’s Fibre Channel Loop ID” on page 38. Otherwise, continue with “Starting the Software” on page 40.

Setting the Controller's Fibre Channel Loop ID

If you are using a fibre channel-arbitrated loop (FC-AL) configuration and have more than 15 controllers on the same loop, you must use the `nvutil` utility to set the preferred loop ID for the controllers on the loop.

If you have 15 or fewer controllers on the same loop, you do not have to set the loop ID. Default values will be assigned when you start the loop. However, each controller in the loop must be set to a unique ID (through switches on the controller tray). Continue with the next section, "Starting the Software" on page 40.

Note – You must specify a device name for the controller whose preferred loop ID you want to set. Otherwise, the loop ID you specify will be assigned to every controller on the loop.

To set the preferred loop ID, type the following:

```
nvutil -i <Loop ID number> <device name>
```

where <Loop ID number> is the preferred loop ID you want to set, and <device name> is the device name for the controller.

You may select a value between 0 and 125 in hexadecimal. Loop ID 126 is reserved for an `FL_Port` or an `N/FL_Port`. Loop ID 127 indicates that the device does not have a hard (or preferred) address. The Loop ID is assigned an arbitration priority with 0 being lowest and 126 being highest. Note that the Loop ID is not the same thing as the Arbitrated Loop Physical Address (`AL_PA`), but rather an index to valid `AL_PAs`.

Bit 7 of Byte 3 is used to indicate one of two modes of operation. If bit 7 is set to 0, then bits 6-0 specify a base value that is added to the Host Bus SCSI ID to create the Loop ID. If bit 7 is set to 1, then bits 6-0 indicate the Loop ID.

Table 3-1 shows possible values and the resulting Loop IDs.

TABLE 3-1 Fibre Channel Loop ID Byte Definition

Bit	7	6	5	4	3	2	1	0	Result
Value	0	0x00 - 0x7f							Loop ID Base (added to Host Bus SCSI ID)
	1	0x00 - 0x7d							Loop ID (Host Bus SCSI ID ignored)
	1	0x7e							No Loop operation; initializes as Point-to-Point or Fabric only
	1	0x7f							No preferred address

For more information about setting controller fibre channel loop IDs, see “Setting FC Loop IDs” in the *Sun StorEdge A3500/A3500FC Controller Module Guide* (805-4980-xx).

Starting the Software

Note – You must have administrator privileges to access this software.

1. Start Open Windows (or CDE), if it is not already running.
2. Start the Sun StorEdge RAID Manager software by typing:

```
/usr/lib/osa/bin/rm6
```

The program group (Figure 3-3) appears and you are ready to select the various applications. For a description of some key terms used in the applications, see the “Common Definitions” section in the *Sun StorEdge RAID Manager User’s Guide* or the Online Help glossary.

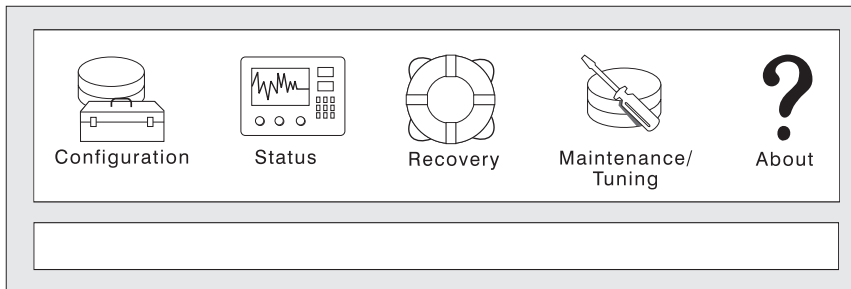

33209

FIGURE 3-3 Main Program Group

3. This software uses the iso8859 font/character set for its various displays. If you do not have these fonts installed, then this software uses available fonts, which could cause minor display problems. If you suspect this is happening, verify that you have the correct Sun font packages installed:

a. At the system prompt, type:

```
pkginfo SUNWxwoft SUNWxcft
```

b. Make sure that at least one of these font packages exists. If they are missing, install them now.

4. Do your modules have an Independent Controller configuration?

No	Yes
Go to “Assigning Names to the Modules” on page 43.	Go to “Setting Up Independent Controllers” on page 42.

Setting Up Independent Controllers

If your RAID Modules are using an Independent Controller configuration, you need to perform the procedure below to indicate the configuration to the storage management software (for a definition of the Independent Controller configuration, see the *Sun StorEdge RAID Manager User's Guide* or the Online Help).

1. **Start any storage management software application.**
2. **When the Module Selection screen is displayed, highlight the module that has independent controllers, and select Edit.**
3. **Click the box next to “Independent Controllers?” and select OK.**

The main Module Selection screen displays again, and the “Indep. Cntrls?” column now says *Yes*.

4. **Assign names to the modules, if desired, and add any comments (you may want to add location details or other unique information to further clarify the module name).**

Note – If you upgraded the storage management software from version 6.0, the RAID Module names may have changed from *<RAID Module XX>* to *<hostname_XXX>*. Using the Module Profile you saved, reassign the original names, if desired.

If you enter characters like “.”, “%”, “:”, or “;” in the name, they will be replaced with “_”.

5. **Repeat this procedure for all modules using this configuration.**
6. **Continue with “Verifying and Upgrading Controller Firmware” on page 44.**

Assigning Names to the Modules

The installation procedure assigns default names to each RAID Module in the following form:

`<hostname_XXX>`

You can assign other names to the modules, if desired, to aid in identifying them.

Note – If you upgraded the storage management software from version 6.0, the RAID Module names may have changed from `<RAID Module XX>` to `<hostname_XXX>`. Using the Module Profile you saved, reassign the original names, if desired.

If you do not want to assign names to the modules at this time, continue with the next section, [“Verifying and Upgrading Controller Firmware” on page 44](#). Otherwise, perform the following procedure:

1. **Start any storage management software application.**
2. **When the Module Selection screen is displayed, highlight the module you want to rename, and select Edit.**
3. **Assign a name to the module and add any comments (you may want to add location details or other unique information to further clarify the module name).**

Note – Do not use period characters in RAID module names. Using period characters in RAID module names can cause the storage management software to function unpredictably.

If you enter characters like “.”, “%”, “:”, or “;” in the name, they will be replaced with “_”.

Sun StorEdge RAID Manager automatically assigns alpha-numeric module names that reflect the host system name. However, if the host name contains reserved characters (for example, the periods in a host system with the name `v4d-1000b.test.com` or in an IP address such as `<user>.124.000.02.002`), the corresponding module names will cause some CLI commands to fail and the Sun StorEdge RAID Manager GUI windows to be displayed incorrectly. Refer to the `storutil` man page for details on renaming RAID modules.

4. Perform this procedure on each RAID Module you want to assign a name to.
5. Continue with the next section, [“Verifying and Upgrading Controller Firmware” on page 44.](#)

Verifying and Upgrading Controller Firmware

If your RAID Modules do not have the most recent version of controller firmware, you need to download the correct version to the RAID Module controllers (including any previously installed RAID Modules). Use the following procedures to determine the current firmware level and to download new firmware, if necessary. See “Controller Firmware Upgrade Notes” on page 121 for more information.

Determining the Controller Firmware Version

Note – Be sure to perform these steps from each host machine if your RAID Modules have the independent controller configuration. In addition, be sure to check the firmware level on all RAID modules attached to the host system.

You can quickly see what controller firmware version a RAID Module’s controllers have by using Module Profile:

1. Start the storage management software by typing:

```
/usr/lib/osa/bin/rm6
```

2. Start the Maintenance/Tuning application.
3. Select the RAID Module you want to check.
4. Select Module Profile → Controllers.
5. Verify the firmware level is correct (see “Controller Firmware Upgrade Notes” on page 121).
6. Select Close when finished viewing.
7. Check *all* the RAID modules on your system.

8. Do all controllers on your system have the required version of firmware?

No	Yes
You <i>must</i> upgrade to the most recent version immediately. Continue with “Upgrading the Controller Firmware Version” on page 45.	Go to with “Running Recovery Guru/Health Check” on page 48.

Upgrading the Controller Firmware Version

You may need to use this procedure to download new controller firmware.

1. **Determine whether you can upgrade the firmware in the Online or Offline mode. For detailed information on which method you should use to upgrade controller firmware, see the *Sun StorEdge RAID Manager User’s Guide*.**

Tip – If you must use the Offline mode, make sure that you stop all I/O to the controllers you are going to upgrade.

2. **Start the Maintenance/Tuning application.**
3. **Select the RAID Module containing the controllers you want to upgrade.**

Note – You can select All RAID Modules to download firmware to all controllers in all RAID Modules. If you are upgrading to the latest firmware level, you may need to upgrade to an intermediate level first. Refer to the *Sun StorEdge RAID Manager Release Notes (805-7758-xx)* for a list of firmware levels and upgrade paths.

4. **Click on the Firmware Upgrade icon or select Options → Firmware upgrade from the pull-down menus.**
5. **Read the Important Notes, and then select OK.**
6. **A screen is displayed asking you to select one procedure:**
 - Online to upgrade firmware while the selected RAID module receives I/O.
 - Offline to upgrade firmware when the selected RAID module is not receiving I/O.

After selecting Online or Offline, the screen displays the message “Verifying the controller state” while the software checks the selected RAID modules for restrictions based on the type of firmware upgrade you selected. If there are no restrictions, a screen like [Figure 3-4 on page 46](#) is displayed.

This display shows the controllers in the selected RAID Modules and their current firmware levels. Make sure both controllers are highlighted here if you want to download firmware to both controllers. Note that for firmware levels 3.0 and higher, the fibre channel level is the same as the firmware level because the fibre channel firmware is contained in the firmware file.

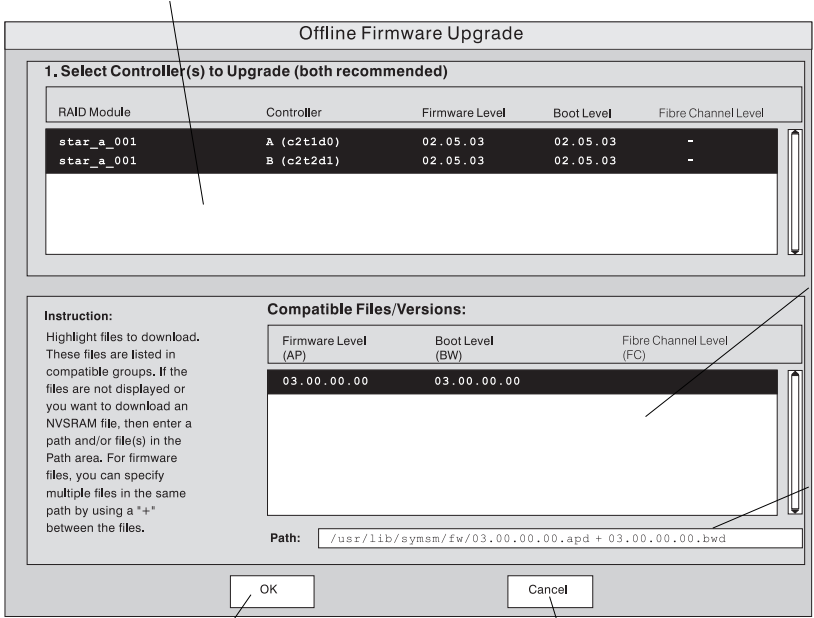

This screen displays the compatible firmware files found using the fwcompat.def file. Highlight the version level you want to download.

Note that for firmware versions 3.0 or higher, the firmware (appware) file contains the fibre channel firmware, so no fibre channel

The path is updated to show the files currently selected in the Compatibility display. You can also enter a file name here to download that file.

Click here to begin the download after you have selected the firmware files to load.

Click here to cancel without downloading any new files.

FIGURE 3-4 Firmware Upgrade Screen

7. Perform the following step to download firmware:

- Highlight the version level you want to download and select OK.

You either receive notification that a problem occurred, or you have a final confirmation that the upgrade process is about to begin.

8. Select OK.

Do not select any other options or exit the Maintenance/Tuning Application until the upgrade process is complete. You can, however, monitor the upgrade progress.

When the upgrade is finished (this should take about 5 minutes), you see a Summary Report indicating whether the upgrade is Successful or Failed.

Note – If you selected All RAID Modules, it is possible that the upgrade was successful for some modules, but not for others. The Summary Report should indicate which modules were not successful and give an appropriate cause.

9. After the download is completed, select OK.

You return to the Maintenance/Tuning screen.

10. You are finished with this procedure. Continue with the next section, “Running Recovery Guru/Health Check” on page 48.

Running Recovery Guru/Health Check

Use the following steps to ensure that the RAID Modules attached to your host system are all operational.

Note – Be sure to perform this step from *each* host machine if you are using the independent controller configuration.

Use the following procedure to run Recovery Guru/Health Check.

1. **Start the Recovery application.**
2. **Select All RAID Modules to check all the modules on your system. A screen like Figure 3-5 is displayed.**
3. **Click the Recovery Guru/Health Check icon or select Options → Recovery Guru from the pull-down menus.**

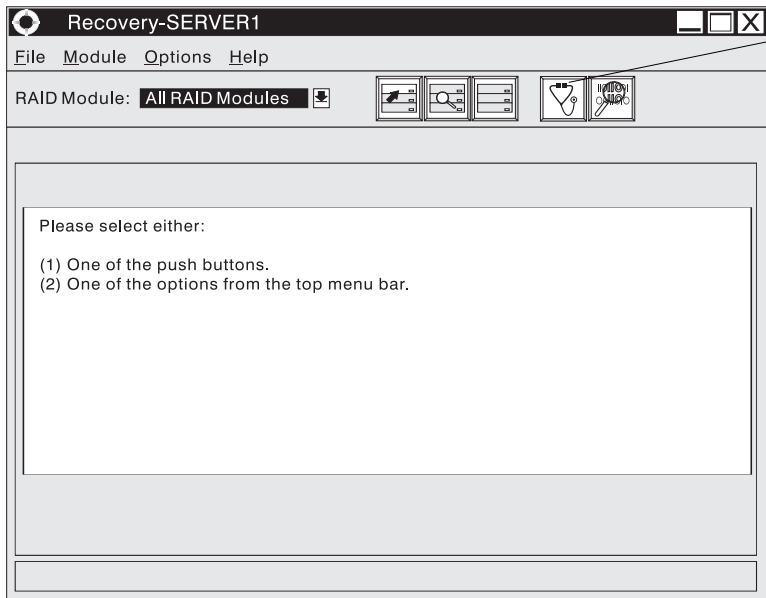

Click here to run Recovery Guru/Health Check on the selected modules. You can also start by selecting Options → Recovery Guru.

33432

FIGURE 3-5 Recovery Main Screen

4. **The software checks all the selected modules for non-optimal statuses.**
 - If all of the RAID Modules have an Optimal status, then you are finished with this procedure. Go to the next section, [“Completing the Installation” on page 51.](#)
 - If a non-optimal status is found, a screen like Figure 3-6 is displayed. Continue with [Step 5.](#)
5. **If exceptions are found, highlight the exception and click on Show Procedures for recommendations on how to fix the problem (see Figure 3-7 on page 50)**

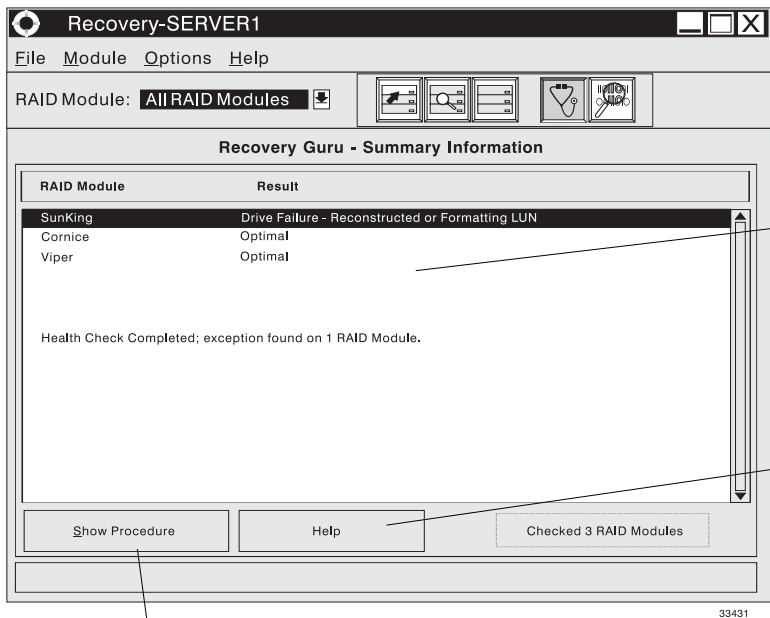

This area displays the results of the check. If a non-optimal status is found, highlight the line and click Show Procedure for recovery information.

Click here for help.

Click here to display information on the highlighted failure. This information includes recovery information. See Figure 3-7 on page 50 for a sample screen.

FIGURE 3-6 Recovery Screen/Exceptions Found

6. Print out the procedure, if desired.
7. Follow the procedure given to recover from the component failure.
8. After correcting any problems, reselect Recovery Guru/Health Check until all RAID Modules are Optimal.
9. Continue with the next section, **“Completing the Installation”**.

Select File here to print the information displayed in the procedure screen, or to set up the printer before printing. Select Edit to copy text to the clipboard.

Although this looks like a standard Help screen, these buttons are grayed out.

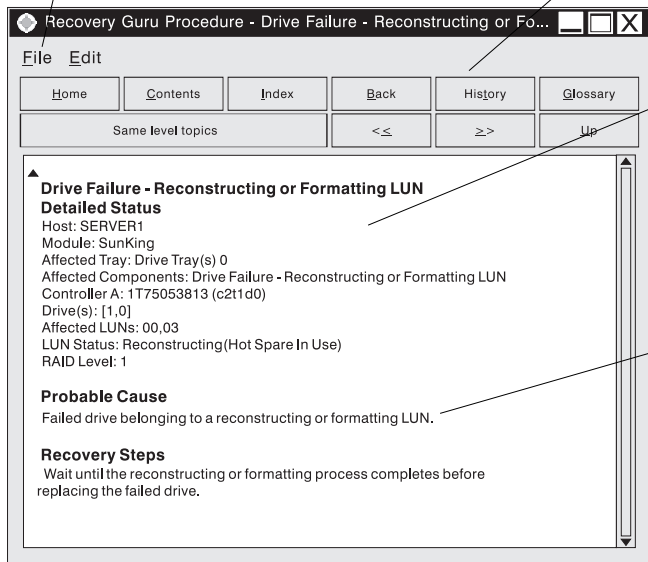

The first part of this area gives detailed status information on the failure. In this case, the message indicates that drive [1,0] has failed. A hot spare drive has taken over for the failed drive is currently reconstructing. LUNs 0 and 3 are affected by this failure.

The rest of this area gives information on the cause of the failure and on how to recover from it. Read the instructions carefully. If necessary, print them out by selecting File → Print Topic from the pull-down menus.

In this case, there is no action to take until the reconstruction is finished. Then you should run Health Check again for information on how to replace the failed drive.

FIGURE 3-7 Recovery Procedure Screen

Completing the Installation

If you are upgrading from a previous version of Sun StorEdge RAID Manager, you are probably finished with the installation procedure and should do the following:

1. **If you added new RAID modules as part of the new software installation, skip the next section, “Determining the Current Configuration.”**
2. **If you made changes in the `rmscript` or `rmparams` files during your previous installation, re-enter those changes in the new file (see Chapter 4, “Customizing the Installation” for more information).**
3. **Otherwise, go to “What’s Next?” on page 64 and decide what you need to do next.**

If you are installing Sun StorEdge RAID Manager for the *first* time, you should do the following:

1. **Examine the configuration of your RAID Modules and make any necessary changes.**
2. **Go to the next section, “Determining the Current Configuration.”**

Determining the Current Configuration

Now that you have successfully installed the software, you need to use it to identify each RAID Module connected to your host system and determine the module's current configuration (number of drives, number of controllers, logical units, and so on).

Note – You must perform this step from each host machine if using the independent controller configuration.

Note – Most RAID Modules come pre-configured with logical units already defined. This logical unit configuration may or may not be desirable for your particular environment.

This software has assigned a name to each RAID Module connected to your host system. These designations are shown in the RAID Module selection list near the top of each application's screen (see [Figure 3-8 on page 53](#)).

Perform the following steps for each RAID Module to identify the module and determine its current configuration. If you need a definition of a Drive Group, RAID Module, or Logical Unit, see the "Common Definitions" section in the *Sun StorEdge RAID Manager User's Guide* or the Online Help glossary.

1. Use the following steps to view the current drive groups and logical units in a RAID Module.

a. Start the Configuration Application.

The Select Module main screen appears. If you have more than one RAID Module connected to your host system, each RAID Module appears in the list.

b. Highlight the first RAID Module in the list, and select OK.

The Configuration application main screen is displayed (see [Figure 3-8](#)). Table 3-2 on page 54 describes the items that are displayed.

c. View the current drive groups and logical units.

As you highlight an element in the Module Information area on the left of the screen, the display on the right changes to show those elements. You *cannot* select or highlight any item in right side of the display (it is information only).

This is the currently selected RAID module.

These buttons are active or grayed out depending on what RAID Module structure is currently selected in the Module Information area to the left

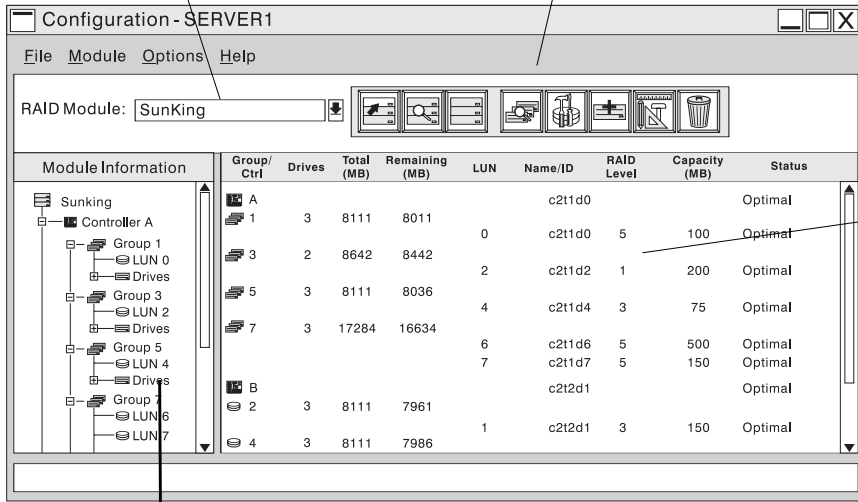

The Detailed Information area gives information on the drive groups and logical units in the RAID Module.

The items displayed here depend on what is selected in the Module Information area to the left.

The information shown in this example is displayed when the RAID Module itself is selected.

See Table 3-2 for a description of the elements in the display.

The Module Information area shows the RAID Module as a directory tree structure. At the top is the RAID Module, then the controllers, then the drive groups owned by the controller, then the logical units and drives in that drive group. At the bottom of the display (not shown here) are the hot spares and unassigned drives. Clicking on the different structures changes the display in the Detailed Information area to the right.

FIGURE 3-8 Configuration Application Main Screen

TABLE 3-2 Configuration Display Columns

Column Heading	Explanation
Group/Ctl	The controller (A or B) or drive group.
Drives	The number of drives in the drive group.
Total (MB)	The total capacity of the drive group, after accounting for RAID level.
Remaining (MB)	The total capacity remaining in the drive group.
LUN	The logical units (LUNs) in the drive group.
Name/ID	The name or ID of the controller, logical unit, or drive, depending on the display. <ul style="list-style-type: none">• Controller and logical unit names are usually assigned by the operating environment and cannot be changed.• Drive IDs are the channel number and SCSI ID of the drives.
RAID Level	The RAID level of the logical unit.
Capacity (MB)	The capacity of the logical unit.
Status	The current status of the logical unit. If a status other than Optimal appears here, run Health Check to determine what the problem is and, if necessary, what action to take.

2. Use the following steps to physically locate and label a RAID Module.

a. In the Module Information Area, highlight the RAID Module you want to locate.

b. Select `Locate Module` \rightarrow `Start`.

The green drive activity lights flash on the drives in the selected module.

c. Physically locate the RAID Module with the flashing activity or fault lights. Once you have identified the RAID Module, place a sticker label on it for future reference.

The label should correspond to the name of the RAID Module you selected in [Step b](#) (for example, `<hostname>_001`, `<hostname>_002`, and so on).

d. Click Stop to stop the flashing of the activity lights.

Note – It is strongly recommended that you save the profile of each RAID Module during initial installation and any time you change your configuration. You can use this information as a reference if you need to perform any recovery or maintenance tasks. See [Step 3](#).

- 3. Use the following steps to save and print a RAID Module's profile information.**
 - a. Select the desired RAID Module, then select File → Save Module Profile.**

A screen shows the different types of information you can save.
 - b. Make sure All is selected (all of the buttons should be depressed), and select OK to save all of the types of information.**

A screen display prompts you to enter a file name.
 - c. Enter an appropriate path and file name on the Selection line, and select OK.**

The information is saved to the path and file name you specified.
 - d. Print the Module Profile information you saved in [Step c](#) using your host system's printer utility.**

- 4. Use the following steps to view a RAID Module's profile. (Optional)**
 - a. Select the desired RAID Module → Module Profile.**

A summary information screen appears (see [Figure 3-9](#)) showing information about the controllers, drives, and logical units in the RAID Module.
 - b. Select Controllers, Drives, or LUNs for more detailed information on these components.**
 - c. Select Close to exit the profile information.**

This display gives information on the selected module.

The screenshot shows a window titled "Module Profile" with a subtitle "Profile for SunKing". It contains a "Summary Information" section with a table of RAID controllers and a "Disk Drives" section. To the right is a "Detailed Information" section with buttons for "Controllers", "Drives", and "LUNs". A "Close" button is at the bottom center. The number "33434" is in the bottom right corner.

Controllers: Name	Serial Number	Mode	Number of LUNs
A (c2t1d0)	1T75053813	Active	4
B (c2t2d1)	1T75053857	Active	4

Disk Drives:
Number of Drives= 20

Detailed Information:
Controllers
Drives
LUNs

Close

33434

Click here to view detailed information on the RAID module controllers.

Click here to view detailed information on the RAID module drives.

Click here to view detailed information on the RAID module logical units.

Click here to exit this screen

FIGURE 3-9 Main Module Profile Screen

5. Use the following steps to view details on specific drives in a drive group. (Optional)
 - a. If you want to know which specific drives are in a particular drive group, highlight **Drives** (in the Module Information display) and select the **List/Locate Drives** button or select **Options** → **List/Locate drives** from the pull-down menus.
 - b. Select the drives you want to locate (click **Select All** if you want to locate all the drives in the group), then click **Locate**.
 - c. Use the drive location information [x,y] provided in the list to physically locate individual drives in the module.

[x,y] corresponds to a specific drive in the RAID Module, and indicates the channel number and SCSI ID for that drive, where the channel number is always listed first. You can also select **Locate** to flash the drives' activity lights in the RAID Module.
 - d. Select **OK** to exit the drive information.
6. Repeat **Steps 1** through **3** (and **4 -5** if desired) for each RAID Module connected to your host system.

You should have enough information to understand the configuration for each RAID Module.
7. Continue with the next section, **“Determining If Any Changes Are Necessary.”**

Determining If Any Changes Are Necessary

In the previous section (“[Determining the Current Configuration](#)”) you should have performed the following tasks for each RAID Module connected to your host system:

<ul style="list-style-type: none">Reviewed each module’s current configuration (controllers, drives, and logical units/drive groups).	Step 1 on page 52.
<ul style="list-style-type: none">Identified each RAID Module using Locate Module, and placed a sticker label on it.	Step 2 on page 54.
<ul style="list-style-type: none">Saved the Module Profile information to a file using File → Save Module Profile, and printed the information.	Step 3 on page 55.

Now, you need to determine if you need to make any changes to the configuration to meet the requirements of your environment.

1. Use [Table 3-3](#) and the Module Profile information you printed to assist you in determining if any changes are necessary.
2. After you determine if you want to change the configuration, continue with the next section, “[Configuring RAID Modules](#)” on page 63.

TABLE 3-3 Possible Parameters to Change (1 of 4)

Parameter	Description	Why Change?	For More Details
General Parameters			
Controller Mode Maintenance/ Tuning	Applicable controller modes are single active, active/passive, or active/active.	If you have an active/passive controller pair, you should consider changing it to active/active for best performance.	<ul style="list-style-type: none"> • See the Maintenance/Tuning chapter in the <i>Sun StorEdge RAID Manager User's Guide</i>. • Use the online help for the Maintenance/Tuning Application.
Auto Parity Check/Repair Maintenance/ Tuning → Options → Auto Parity Settings	An automatic parity check/repair process runs each week or each day at a specific time. Default is auto parity enabled once per week.	If you want to disable the check/repair or change the time when it runs.	
Hot Spare Drives Configuration → Create Hot Spare	A hot spare drive is a drive that acts as a standby if a drive fails in a RAID 1, 3, or 5 logical unit. The hot spare adds another level of redundancy to your RAID Module.	If you want to create new or additional hot spare drives for added protection.	<ul style="list-style-type: none"> • See the Configuration chapter in the <i>Sun StorEdge RAID Manager User's Guide</i>. • Use the online help for the Configuration Application.
Monitoring Interval Status → Options → Log Settings	The array monitor checks the RAID Modules periodically looking for events and failures. The default is to check every 5 minutes.	If you want to increase or decrease the frequency of the checking interval. If you have a lot of modules, you may need to increase this interval because the amount of time needed to check and return results can increase.	<ul style="list-style-type: none"> • See the Status chapter in the <i>Sun StorEdge RAID Manager User's Guide</i>. • Use the online help for the Status Application.

TABLE 3-3 Possible Parameters to Change (2 of 4)

Parameter	Description	Why Change?	For More Details
Logical Unit Parameters			
RAID Level Configuration → Options → Modify or Configuration → Delete, then Create LUN	Specifies how the data is striped across the drives and whether the drive group has redundancy.	If the current RAID Level is not appropriate for your environment, or you need to change the number of drives. If you do not have the minimum controller firmware level, you cannot use the dynamic capacity options, and you need to delete and recreate the logical unit/drive group you want to change.	<ul style="list-style-type: none"> • See the Configuration chapter in the <i>Sun StorEdge RAID Manager User's Guide</i>. • Use the online help for the Configuration Application.
LUN Capacity Configuration → Delete, then Create LUN → Options	Specifies in megabytes (MB) how much capacity is available on the logical unit.	If you want to increase the capacity of the LUN group (you will need to delete the LUN and recreate it).	

TABLE 3-3 Possible Parameters to Change (3 of 4)

Parameter	Description	Why Change?	For More Details
<p>Segment Size</p> <p>Configuration → Modify Group/ LUN → Segment Size</p> <p>or</p> <p>Configuration → Delete, then Create LUN → Options</p>	<p>Specifies in 512-byte blocks how much data is written to one drive before data is written to another drive in the group.</p>	<p>If the segment size is not appropriate for your environment.</p> <p>If you do not have the minimum controller firmware level, you cannot use the dynamic capacity options, and you will be required to delete and recreate the logical unit/drive group you want to change.</p>	<ul style="list-style-type: none"> • See the Configuration chapter in the <i>Sun StorEdge RAID Manager User's Guide</i>. • Use the online help for the Configuration Application.
<p>Drive Group Capacity (Number of Drives in Group)</p> <p>Configuration → Modify Group/ LUN → Capacity</p> <p>or</p> <p>Configuration → Delete, then Create LUN</p>	<p>Specifies in megabytes (MB) how much capacity is available in the drive group.</p>	<p>If you want to increase the size of a drive group.</p> <p>If you do not have the minimum controller firmware level, you cannot use the dynamic capacity options, and you will have to delete and recreate the drive group you want to change. Also, if you want to <i>decrease</i> the number of drives in the group, you must delete the LUN and recreate it.</p>	

TABLE 3-3 Possible Parameters to Change (4 of 4)

Parameter	Description	Why Change?	For More Details
<p>Caching Parameters</p> <p>Configuration → Create LUN → Options</p> <p>Maintenance/ Tuning</p>	<p>Specifies the caching parameters for each logical unit.</p>	<p>If you want to enable or disable any of these parameters.</p>	<ul style="list-style-type: none"> • If you are creating <i>new</i> logical units, see the Configuration chapter in the <i>Sun StorEdge RAID Manager User's Guide</i> or use the online help. • To change caching parameters on <i>existing</i> logical units, see the Maintenance/Tuning chapter in the <i>Sun StorEdge RAID Manager User's Guide</i> or use the online help.
<p>LUN Assignment and LUN Balancing</p> <p>Configuration → Create LUN → Options</p> <p>Maintenance/ Tuning</p>	<p>Determines what controller owns which logical units/drive groups.</p>	<p>To reassign or balance the logical units/drive groups between controllers in an active/active controller pair.</p>	<ul style="list-style-type: none"> • If you are creating <i>new</i> logical units, see the Configuration chapter in the <i>Sun StorEdge RAID Manager User's Guide</i> or use the online help. • To change LUN Assignments on <i>existing</i> logical units, see the Maintenance/Tuning chapter in the <i>Sun StorEdge RAID Manager User's Guide</i> or use the online help.
<p>Reconstruction Rate</p> <p>Maintenance/ Tuning</p>	<p>Determines how quickly reconstruction occurs on a logical unit when a failed drive is replaced.</p>	<p>To increase or decrease the reconstruction performance.</p>	<ul style="list-style-type: none"> • See the Maintenance/Tuning chapter in the <i>Sun StorEdge RAID Manager User's Guide</i>. • Use the online help for the Maintenance/Tuning Application.

Configuring RAID Modules

Do you need to make changes to your RAID Module configuration?

No	Yes
Go to “Adding Logical Units to the Operating Environment” on page 64.	Go to “Configuring Logical Units on the RAID Module” below.

Configuring Logical Units on the RAID Module

Use the Configuration Application in the RAID Manager software to view the current logical unit configuration and to make any necessary changes.

Note – Refer to the *Sun StorEdge RAID Manager User’s Guide* for detailed information on using the Configuration Application.

1. Start the Sun StorEdge RAID Manager software by typing:

```
/usr/lib/osa/bin/rm6
```

2. Start the Configuration application. The Configuration application main screen is displayed.
3. Set up the logical units with the desired drives, RAID levels, and parameters.
4. Continue with the next section, “Adding Logical Units to the Operating Environment.”

Adding Logical Units to the Operating Environment

1. **After you create or delete logical units (LUNs) using the Configuration Application, you do not need to reboot your system. However, you must make the logical units (whether you created new logical units or not) a part of the operating environment. The following considerations apply:**

- Creating the logical unit creates partitions and node names for the new device, and automatically adds Redundant Disk Array Controller (RDAC) support to the new LUNs (if RDAC is enabled).
- After creating the logical unit, you may need to re-partition it (with the Solaris format command) and add file systems, if desired.

Refer to your Solaris documentation for details on adding a drive, if necessary. Remember, each logical unit (not a drive group) is seen by the operating environment as *one* drive.

2. **Continue with the next section, “What’s Next?” on page 64.**

What’s Next?

Now that you have successfully completed the installation of the software, do one of the following:

- Refer to the *Sun StorEdge RAID Manager User’s Guide* for detailed information on how to use each application.

Note that Chapter 5, “Operating Environment Support” gives information specific to the Solaris operating environment.

- Go to Chapter 4, “Customizing the Installation” if you want to set up SNMP notification or make other changes to the software.
- Go to [Chapter 6, “Troubleshooting”](#) for troubleshooting tips on common problems you may encounter as you use this software with the Solaris operating environment.

Customizing the Installation

This chapter describes how to customize your installation and make changes to fully support the storage management software in the Solaris operating environment. If you are upgrading this software from a previous version, be sure to review this material to determine if you want to make any changes.

- Changing the `rmparms` File—page 66
- Setting Up Scriptable Notification Options—page 70
- Setting Up SNMP Notification—page 72

Changing the `rmparams` File

The `/etc/osa/rmparams` file is used to store several configurable options available through Sun StorEdge RAID Manager.

You need to change options in this file if you:

- Want to increase the number of controllers allowed on the system.
- Want to support more than eight LUNs on your RAID modules (see [“Setting the Logical Unit Limit” on page 36](#)).
- Want to enable/disable SNMP notification.

Note – You must edit the `rmparams` file enable SNMP notification (see [“Setting Up SNMP Notification” on page 72](#)).

- Are upgrading the storage management software and want to make customized changes to this file. Use the original `rmparams` file that you saved to determine the changes you want to make. Remember, the new file contains new parameters for this version, so do *not* replace it with the old file.
- Are installing this software for the first time and want to review the changes you can make.

TABLE 4-1 shows a list of the parameters in the file that you may need to change during (or after) initial installation. Most options (other than the ones shown in TABLE 4-1) in the `rmparams` file should *not* be changed, and many of the other options should only be changed through the graphical user interface (GUI).

A listing of the entire `rmparams` file is provided in [“`rmparams` File Listing” on page 124](#). For more information, see the `rmparams` man page.

Note – Because of the critical nature of the `rmparams` file, a backup copy of this file has been installed in the `/usr/lib/osa/` directory and is named `rmparams.install`. If the `/etc/osa/rmparams` file becomes corrupted or missing, copy this file to the `/etc/osa` directory to resume normal operation. If you make any changes to this file directly or use the options in the GUI that write to this file (such as log settings, auto parity settings, and so on), always copy the new version of the file to the `/etc/osa` directory.

▼ To Edit the `rmparams` File

1. **Before making any changes to the `rmparams` file for the first time, save the original file and copy it to the backup file `/usr/lib/osa/rmparams.orig`.**
2. **Make any necessary changes to the `rmparams` file using TABLE 4-1.**
3. **Save the `rmparams` file, and copy it to the backup file `/usr/lib/osa/rmparams.current`.**



Caution – You need to increase the `System_MaxLunsPerController` parameter if you are running Solaris 2.6 software and can support more than eight LUNs on any RAID Module, because this parameter also affects the highest LUN number that the Sun StorEdge RAID Manager software displays. For example, if you have LUNs 0, 3, and 31 configured on a RAID Module, LUN 31 would not appear in the display if this parameter were only set to 8.

Note – Remember that this limit applies to a RAID Module (whether it has a single controller or redundant controllers). Therefore, if you have a RAID Module with 2 active controllers, the total number of LUNs between them cannot be more than 32.

4. **Continue with “Setting Up Scriptable Notification Options.”**

TABLE 4-1 Changeable Parameters in `rmparams` File

Parameter	Description	When To Change	How To Change
<code>SNMP_Target_IP_Address=127.0.0.1</code>	Provides the SNMP IP Address for remote notification.	If you want to enable SNMP notification.	See “Setting Up SNMP Notification” on page 72.
<code>SNMP_Community_Name=NONE</code>	Provides the community name to be used for SNMP remote notification.	If you want to enable SNMP notification.	See “Setting Up SNMP Notification” on page 72.
<code>SNMP_Action_Number=0</code>	Indicates the SNMP trap notification option you want to use.	If you want to enable SNMP.	<p>Change this value to 1 or 2.</p> <p>A value of 1 sends SNMP traps to the designated NMS station. A value of 2 writes all relevant data to the <code>/usr/lib/osa/bin/trap.dat</code> file.</p> <p>SNMP writes to this file when there is a trap. When an SNMP daemon process finds the file, it performs the requested action, and deletes the file. Therefore, the file is not actually “stored” in this location.</p> <p>Important: Setting this parameter to 0 will completely disable the SNMP option.</p>
<code>System_DefaultModuleSelect=TRUE</code>	Determines whether the Select Module main screen is displayed each time you open an application.	If you want to disable the Module Selection screen so that it is not displayed each time you open an application.	Edit the <code>rmparams</code> file and change TRUE to FALSE.

TABLE 4-1 Changeable Parameters in `rmparams` File

Parameter	Description	When To Change	How To Change
<code>System_MaxControllers=32</code>	Determines the maximum number of RAID Controllers supported by Sun StorEdge RAID Manager.	If you have more than 32 RAID controllers.	Edit the <code>rmparams</code> file and change "32" to the appropriate number.
<code>System_MaxLunsPerController=8¹</code>	Determines the maximum number of logical units supported per RAID Module, and also sets the highest LUN number displayed by this software.	After determining if you can support more than eight LUNs (see "Setting the Logical Unit Limit" on page 36).	Edit the <code>rmparams</code> file and change the number of LUNs, for example, 32.

Important: ¹You need to increase the `System_MaxLunsPerController` parameter if you can support more than eight LUNs on *any* RAID Module because this parameter also affects the highest LUN number that the storage management software displays. For example, if you have LUNs 0, 3, and 31 configured on a RAID Module, LUN 31 would not appear in the displays if this parameter were only set to 8.

Note: Remember that this limit applies to a RAID Module (whether it has a single controller or redundant controllers). Therefore, if you have a RAID Module with two active controllers, the total number of LUNs between them cannot be more than 32.

Setting Up Scriptable Notification Options

The `rmscript` file is accessed by the status monitor and automatic parity check whenever these utilities find an exception. By default, no action is taken. You can edit this file to specify a set of actions to take when an error is found.

For example, if you want to install third-party notification software to perform various events (such as faxing or paging), you would add the appropriate script for each event near the end of this file (making sure the last line is always `rm $1`). Consult the third-party's software documentation for specific details.

Note – If you installed an upgrade of the storage management software, you may want to refer to the `/usr/lib/osa/bin/rmscript` file to determine if you want to make additional customized changes to the new file. Remember, the new file contains a new script for this version, so you must *not* replace it with the old file.

For more information, read the `rmevent` man page. From this software's installation directory, type:

```
man rmevent
```

Editing Example

The following procedure provides an example for editing the `rmscript` file to add two scripts for extracting information during a defined event and dispatching a paging command.



Caution – The last line in the `rmscript` file must *always* be `rm $1`. Therefore, when editing this file, always place any new event script above this line.

- 1. To look for AEN events and create a command for a sendpage, add the following event script near the end of the `rmscript` file:**

```
# Use AWK to parse the common fields of the record.

eval `awk -F\~ `NF > 0 {print "TYPE=" $6 ";HOST=" $1 ";CONTROLLER=" $2 \
";DATE=" $5 ";TIME=" $6}` < $1`

# Simple test for AEN events. If one received, send a page to
# someone interested in any AEN event.
if [ $TYPE = "00" ]
then sendpage "John H. User" "AEN event on $HOST"
fi
```

- 2. To look for parity errors and create a command for a sendpage, add the following event script *below* the event script you added in Step 1:**

```
# Similar test, but for parity errors.
if [ $TYPE = "20" ]
then sendpage "John H. User" "Parity errors found on ($HOST, $CONTROLLER)"
fi
```

Setting Up SNMP Notification

This software can provide remote notification of RAID events to designated network management stations (NMS) using Simple Network Management Protocol (SNMP) traps. Use the information in this section to set up the NMS, to enable or disable this notification option for specific hosts, and to understand the contents of an SNMP trap message.

To enable SNMP notification on your host, you must edit the `/etc/osa/rmparams` file so that the software will know where to direct the SNMP trap messages when a RAID Event has occurred. See “Changing the `rmparams` File” on page 66.

You need to set up your designated NMS only once. Use the following procedure to compile the Sun StorEdge RAID Manager Management Information Base (MIB) into your NMS.

▼ To Set Up the NMS

Note – The MIB was written to standard version 1 SNMP syntax. It was designed specifically for Sun StorEdge RAID Manager. It is not applicable to other vendor RAID products.

1. **Copy the `/usr/lib/osa/rm6traps.mib` file to the network management station.**
2. **Follow the steps required by your specific network management station to compile the MIB.**

Note – For details on the required steps, consult your network administrator or the documentation specific to the NMS product you are using.

▼ To Enable SNMP

1. Edit the `/etc/osa/rmparams` file as follows:

- a. Include the IP address of the host that has the SNMP-trap proxy agent. For example:**

```
SNMP_Target_IP_Address=129.146.243.54
```

- b. Define the community name. For example:**

```
SNMP_Community_Name=public
```

2. Make sure the `/etc/resolv.conf` file exists, even if it is empty.

3. Make sure that the `/etc/osa/locks/rmparams.lock` file is writable by root.

This can be a problem if the Sun StorEdge RAID Manager software is NFS mounted.

4. Make sure that the `/usr/lib/osa/rm6traps.mib` file is compiled and imported by the network management system.

For example, if you are using SunNet Manager, the command `mib2schema rm6traps.mib` creates the following files:

- `rm6traps.mib.schema`
- `rm6traps.mib.oid`
- `rm6traps.mib.traps`

The `rm6traps.mib.schema` and `rm6traps.mib.oid` files are placed in the `/opt/SUNWconn/snm/agents` directory.

The `rm6traps.mib.traps` file is appended to the `/var/opt/SUNWconn/snm/snmp.traps` file.

When an array event occurs, the script `rmscript(1M)` takes the information passed by `arraymon(1M)` and constructs an SNMP trap message and then sends it to the host defined in the `/etc/osa/rmparams` file.

See your network management system documentation for more information on how to install SNMP devices.

5. Make sure the host system is connected to the network with the NMS station.

6. Enable this notification on your host. You must edit three parameters in the `/etc/osa/rmparams` file so that the software will know where to direct the SNMP trap messages when a RAID Event has occurred.

Disabling SNMP

Perform the following steps to disable this notification on your host and stop this software from sending SNMP traps:

1. In the `/etc/osa/rmparams` file,

- Delete the `SNMP_Target_IP_Address` line.

Or

- Change the value of the `SNMP_Community_Name` line to `NONE`.

Or

- Change the value of the `SNMP_Action_Number` line to `0`

See “Changing the `rmparams` File” on page 66.

2. Save the `rmparams` file and copy it to the `/etc/default` directory. It is critical that you have a backup copy of this file.

SNMP Trap Message Description

TABLE 4-2 describes the contents of an SNMP trap message for Sun StorEdge RAID Manager.

Note – If the trap type is other than informational, use the Status or Recovery Applications to get more information or specific instructions on how to remedy the problem. Do *not* remove the SNMP message until the problem has been corrected since most trap notifications associated with this software are not persistent.

TABLE 4-2 SNMP Trap Message Descriptions

Item	Description
Host IP Address	The standard IP address dot notation for the host where the RAID Module is attached.
Host Name	The text name assigned to the host.
Trap Type	There are four trap types: Informational – No failure has occurred. Information is provided that an event, such as a logical unit creation, has occurred. Degraded Array – A subsystem component failure has occurred. The module is still operational but now lacks redundancy in some area. (For example, a drive failure resulting in a degraded logical unit, a power supply failure, or a failure of one controller in a controller pair.) Failed Array – A failure has occurred that leaves a module or logical unit unable to communicate. (For example, a failure of the controller in a single-controller RAID Module or a multiple drive failure resulting in a dead logical unit.) Critical – This is a small category of failures that may require timely intervention to correct. (For example, the two-minute warning from an uninterruptible power supply or a warning that write-back cache has been disabled due to a low battery.)
Affected RAID Module	Indicates which RAID Module had the event (for example, RAID Module 01).
Condition Description	A brief description of the event.

Operating Environment Support

This chapter covers the following topics related to operating the storage management software in the Solaris environment:

- Naming Conventions—page 78
- Creating and Deleting Logical Units—page 79
- The Background Monitor—page 81
- Using Sun StorEdge™ Volume Manager—page 82
- Redundant Controller Support (RDAC)—page 83
- Command-Line Interface—page 86
- Adding New RAID Modules to the Configuration—page 87
- Deinstalling RAID Manager—page 88

Naming Conventions

Module Names

By default, module names are assigned in the order in which the system detects the module. The default name displayed is derived from the name of the host machine where the storage management software is installed, for example, `<hostname>_001`, `<hostname>_002`, and so on.

You can also assign your own names to modules. See “Assigning Names to the Modules” on page 43 for more information about naming RAID modules.

The controllers and logical units in the module have unique device names. See the next section, “Controller and LUN Names” for more information.

Controller and LUN Names

The storage management software uses device names in the form `c<x>t<y>d<z>`, where `<x>`, `<y>`, and `<z>` are numeric values giving the hardware location of the subsystem hardware. [Figure 5-1](#) shows the format of the device name.

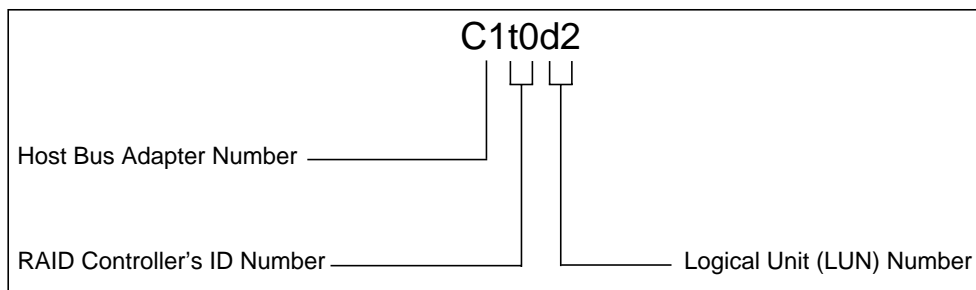

FIGURE 5-1 Device Name Example

Note that the RAID Module controller has the same device name as LUN 0 on that RAID module (both use `d0`).

This software includes the device name in various screen displays, and the address usually indicates the path to a specific logical unit. If you transfer LUN ownership between controllers (Maintenance/Tuning → LUN Balancing), the device name is updated.

Creating and Deleting Logical Units

Number of LUNs

The number of logical units per RAID module depends on the type of host adapters you are using, on the hardware configuration, on the Solaris operating environment version, and on the installed patches. The number of LUNs should be set during installation. If you need to change the number of allowed LUNs after installation, see “Setting the Logical Unit Limit” on page 36.

There is a maximum value of 255 LUNs per host adapter. This limit cannot be exceeded.

Refer to the *Sun StorEdge RAID Manager Release Notes (805-7758-xx)* for detailed information about the number of LUNs per RAID module that are supported for the various combinations of host connection, host adapter, Solaris operating environment version, and patch level.

Creating LUNs

After you create logical units (LUNs) using the Configuration application, you do not need to reboot your system. You do have to make them part of the operating environment. The following considerations apply:

- Creating the logical unit creates partitions and node names for the new device, and automatically adds RDAC support to the new LUN (if RDAC is enabled).
- After creating the logical unit, you may need to re-partition it (with the Solaris `format` command) and add file systems, if desired.

Refer to your Solaris software documentation for details on adding a drive. Remember, each logical unit (not a drive group) is seen by the operating environment as *one* drive.

Deleting LUNs



Caution – If you are using the RAID Module as a boot device (see [Chapter 3](#)), do *not* delete LUN 0 or use File → Reset Configuration, or you will lose your boot device.

Before deleting LUNs with this software, or using File → Reset Configuration, perform the following procedure:

- 1. Unmount any file systems on the affected logical units (or stop all I/O to the LUNs if there are no file systems).**
- 2. Delete the logical units with the storage management software (or reset the configuration).**
- 3. Refer to your Solaris software documentation for other procedures required to delete a drive.**

Note – When you delete a logical unit, the device nodes for that logical unit remain on the system. These nodes will be deleted the next time you reboot (with the `boot -r` command). In the meantime, these nodes should not cause any problems unless the operating environment tries to access them (in this case, you will receive an error message).

The Background Monitor

The storage management software has a background monitor (`arraymon`) that automatically polls all RAID Modules and checks for problems and events at specified intervals. If any problems or events are detected, the information is written to the default log file. This becomes an historical record of past component failures, general status changes, and configuration changes.

You can change the 5-minute default polling interval. For best results, use the default value or smaller to ensure that you are notified about problems and events as close as possible to the time when they occur.



Caution – Setting this value too small (with `Status` → `Options` → `Log Settings`) may cause the check to affect system I/O performance. Setting this value too large may delay notification of serious problems.

Stopping the `arraymon` Process



Caution – You should stop `arraymon` *only* if you are specifically instructed to do so by `Recovery Guru`, troubleshooting documentation, or your customer services representative. However, doing so means that *none* of the RAID Modules connected to the host will be checked during this time. Be sure to restart the monitor when instructed.

1. Type the following:

```
ps -ef | grep arraymon
```

2. Note the process number of the `arraymon` daemon and use it in the next step.
3. Type:

```
kill -9 <process_number>
```

Starting the arraymon Process

The `arraymon` process automatically starts when you run the storage management software. However, it is necessary to manually start this process if you have stopped it for some reason.

1. Type:

```
/etc/init.d/amdemon start
```

2. Run Recovery Guru/Health Check to make sure that no problems have occurred while you had the disk array monitor stopped.

Using Sun StorEdge™ Volume Manager

If you are using Sun Storage Volume Manager software and want to perform any RAID Manager software operation that requires exclusive access to LUNs, you must first remove the affected logical units or drive groups from the control of Volume Manager and then unmount the devices.

Note – If the Sun Storage Volume Manager 2.6 software is installed on your system, a default feature known as Dynamic Multi-Pathing (DMP) is *active* by default. The Sun StorEdge RAID Manager software and the A3x00 RAID array do not support DMP. Redundant I/O pathing is maintained internally by the Sun StorEdge RAID Manager software. Therefore, you must disable the DMP feature in Volume Manager and reboot the system.

Refer to the *Sun StorEdge Volume Manager 2.6 Release Notes (805-5708)* and the *Sun StorEdge Volume Manager 2.6 System Administrator's Guide (805-5706)* for detailed information about disabling the DMP feature in Volume Manager.

Some storage management operations that require exclusive access to LUNs include:

- Deleting logical units with `Delete for LUNs and File → Reset Configuration (Configuration)`
- Formatting a LUN with `Options → Manual Recovery → Logical Units (Recovery)`
- Upgrading firmware with `Firmware Upgrade → Offline method (Maintenance/Tuning)`.

For example, you would perform the following steps to remove a drive:

1. Remove the LUN from its disk group by typing:

```
vxdbg [-g groupname] rmdisk <diskname>
```

For example, type: `vxdbg -g rootdg rmdisk disk01`

2. Remove the LUN from Volume Manager control by typing:

```
vxdisk rm <devname>
```

For example, type: `vxdisk rm c1t0d0s2`

3. Place the physical LUN offline by typing:

```
vxdisk offline <devname>
```

For example, type: `vxdisk offline c1t0d0s2`

Refer to the *Sun StorEdge Volume Manager 2.6 System Administrator's Guide (805-5706)* for more information on removing drives.

Redundant Controller Support (RDAC)

The storage management software supports redundant controllers on a Solaris system using the Redundant Disk Array Controller (RDAC) driver. The RDAC driver and its associated resolution daemons are installed automatically. For RAID Modules with redundant controllers, this host-based driver layer manages the I/O connection and creates special path names to the devices that you can use instead of the standard device nodes.

If a component fails on the data connection (interface cable/terminator, controller, host adapter, and so on) and the host loses communication with a controller, the RDAC driver automatically re-routes all I/O operations to the other controller.

[Figure 5-2 on page 84](#) illustrates how RDAC provides this redundancy. Normally, the host application generates a request for I/O which goes through just the SCSI driver to get to the controllers/drives. With RDAC installed, though, the RDAC driver and resolution daemon are added for transparent failover. This does not affect performance.

In the [Figure 5-2](#), the host generates a request for I/O to Controller A, but Controller A fails. Use the information in the legend list to follow the I/O connection.

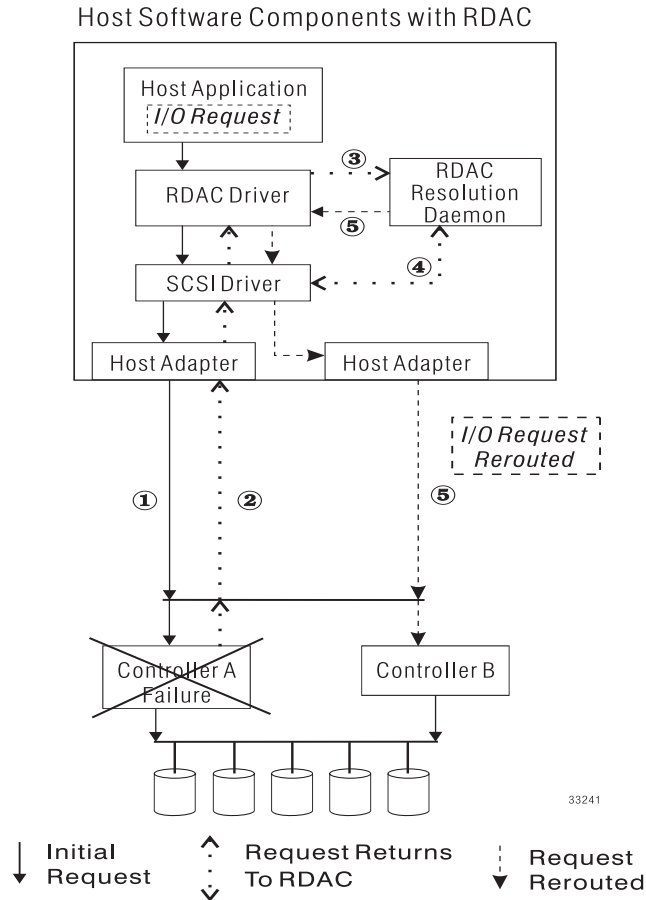

FIGURE 5-2 Example of RDAC I/O Connection Redundancy

Legend:

1. I/O request fails.
2. Failed I/O returns to RDAC driver.
3. RDAC driver requests RDAC resolution daemon for assistance.
4. RDAC resolution daemon performs failover through the SCSI driver and transfers logical units to other controller (controller B).

- RDAC resolution daemon tells the RDAC driver that the new path is ready and RDAC driver resends the I/O request back down to controller B where it is serviced. (The host application is unaware of the transactions that have taken place to complete the I/O.)

Disabling RDAC

You can disable the RDAC protection by editing the `Rdac_SupportDisabled` parameter in the `/etc/osa/rmparams` file and setting the value to `TRUE`. You also need to run the script `/usr/lib/osa/bin/hot_add` or reboot your system (using the `boot` command) for this change to take effect. See the `rmparams` man page for an explanation of this parameter.

Caution – If you do *not* have RDAC protection, certain features do not work as described in the *Sun StorEdge RAID Manager User's Guide*:

Recovery. Recovery Guru/Health Check displays the Data Path Failure type; however, the fault light on the RAID Module will not light when RDAC is disabled. Therefore, thoroughly verify that the interface cable/terminator is not removed or damaged before proceeding with any controller-related recovery procedure.

Maintenance/Tuning. Does not check for I/Os or verify that LUNs are Optimal before upgrading firmware, balancing LUNs, or changing controller mode.

Firmware Upgrade. The Online method for Firmware Upgrade is grayed out. Before selecting the Offline method of Firmware Upgrade, you must stop I/O and unmount any file systems contained on the affected LUNs.

LUN Balancing and Controller Mode. Make sure you stop I/Os or they may fail. Also, if the LUNs contain file stems, you must first unmount them.

Command-Line Interface

Although you can perform most necessary storage management tasks through the storage manager software, there are utilities that enable you to perform these tasks through the command line. Some tasks are carried out automatically by *daemon* processes that run from system startup to system shutdown. For a list and a description of these utilities, see the “Command-Line Interface” in the *Sun StorEdge RAID Manager User’s Guide*.

man Pages

Several man page files were copied to the following directories during this software’s installation:

- /usr/share/man/man1m
- /usr/share/man/man4
- /usr/share/man/man7

The man pages provide supplementary information for storage management and administration. For more information about the man page files, see “man Pages” on page 131.

To install the man pages, perform the following steps:

1. **Become superuser (if you are not already superuser) using the `su` command and the superuser password.**
2. **Type the following at the system prompt:**

```
# /bin/catman -w
```

Note – It may take several minutes for `/bin/catman -w` to run, depending on your system’s processor speed and on which version of the Solaris operating environment you are running.

To access the man pages, type:

```
man <manpagename>
```

For example, to read the `rm6` man page (which gives an overview of this software), type:

```
man rm6
```

Adding New RAID Modules to the Configuration

If you need to add new RAID Modules to your system after installing the storage management software, use the following procedure to be sure this software recognizes the new module and that its configuration meets your needs.

Tip – This procedure assumes that you have not changed the *Rdac_HotAddDisabled* parameter in the `/usr/lib/osa/rmparams` file. If you have changed the parameter, you may need to shut down and reboot the system after adding the module (see the `rmparams` man page for details).

1. **Physically connect the RAID Module to your system. Consult the appropriate hardware documentation for this procedure.**
2. **Execute the following script:**

```
/usr/lib/osa/bin/hot_add
```

Note – You do not need to reboot the system.

3. Go to Chapter 3, “Initial Startup” to perform the following steps:

- Verifying and Upgrading Controller Firmware—page 44
- Running Recovery Guru/Health Check—page 48
- Determining the Current Configuration—page 52
- Determining If Any Changes Are Necessary—page 58
- Configuring RAID Modules—page 63

Deinstalling RAID Manager

If you need to remove the storage management software (for example, to reinstall if there is some problem during the installation procedure), use the `pkgrm` utility and follow the instructions on the screen. See also “Removing an Earlier Version of Sun StorEdge RAID Manager” on page 32.

The `rmlog.log` file remains after using `pkgrm` to remove the software. Although keeping this file should not cause any problems, you may want to manually delete it.

Note – You cannot use the `pkgrm` utility on the storage management software if the RAID Module is the boot device.

Troubleshooting

This chapter contains the following sections:

- Resolving Problems—page 90
- Replacing Controllers—page 107

The troubleshooting tables that follow provide probable cause and action to take for specific problems you may have as you use the storage management software in the Solaris operating environment.

Tip – If you cannot find the problem you are looking for, read the *Sun StorEdge RAID Manager Release Notes* and consult the Online Help for additional troubleshooting information. Also, see “Understanding the Restrictions” on page 6, for additional information.

This chapter includes important information that you may need when replacing failed controllers.

Resolving Problems

The troubleshooting tables that follow provide probable cause and action to take for specific problems you may have as you use the storage management software in the Solaris operating environment.

Tip – If you cannot find the problem you are looking for, consult the Online Help for additional troubleshooting information. Also, see “Understanding the Restrictions” on page 6 for additional information.

Locating Solutions

To quickly find the problem-solution you are looking for, use the following tables to locate the problem you are having. It is possible for an entry to appear in more than one table:

- **Category**—Organizes problems into general use or specific option groups (page 91).
- **Component**—Organizes problems by hardware components, such as controllers, drives, modules, and so on. (page 91).
- **Application**—Organizes problems for each storage management application, including a group for options common to all applications (page 94).
- **Software**—Organizes problems by operating system, storage management software, or command-line options (page 96).

Category

Table 6-1 groups problems into sections for general use or specific options.

TABLE 6-1 Troubleshooting Entries by Category

Category	See Page
“Configuration Application”	97
“Firmware Upgrade”	99
“General”	100
“Recovery Guru/Health Check”	103

Component Search

Table 6-2 lists individual problems by hardware components, such as controllers, drives, LUNs, RAID Modules, and so on.

TABLE 6-2 Troubleshooting Entries Organized by Component *(1 of 3)*

Component	Problem	See Details
Batteries	Age did not reset for both controllers	102
	Battery alert displayed after a controller is replaced or power-cycled	106
Controllers	Failed during alternate replacement	100
	Firmware upgrade failed	99
	Unable to highlight during firmware download	99
	LUN creation error after deleting all LUNs or using Reset configuration	98
	Not visible to storage management software	101
	Passive, no LUNs owned after replacement	105
Fans	Failure detected after replacement	103

TABLE 6-2 Troubleshooting Entries Organized by Component *(2 of 3)*

Component	Problem	See Details
Drives	Lights don't flash (Configuration → List/Locate Drives)	97
	All drives failed in a drive group	105
	Failed status, but LUN is Optimal	104
	Fault light comes on after replacing failed drive	104
	Fault lights lit (drives continue to fail)	104
	Missing information in Manual Recovery → Drives screen	105
	Number of drives incomplete or wrong during LUN creation	97
	Removed drive; no failure reported	103
	Status other than Optimal	104

TABLE 6-2 Troubleshooting Entries Organized by Component (3 of 3)

Component	Problem	See Details
LUNs	Error message during LUN creation after deleting all LUNs or using Reset Configuration	98
	Less capacity shows than selected during configuration	97
	Missing information in Manual Recovery → LUNs screen	105
	No Such Device or Address message displayed during LUN creation	98
	Not visible to storage management software	101
	Number of drives incomplete or wrong during LUN creation	97
	Optimal LUN status with failed drives	104
	Reconstructing status appears, but no drives replaced	104
	Status other than Optimal	104
	Status remains Reconstructing	105
	Not visible under Format	100
RAID Modules	Failure detected after replacing fan or power supply	103
	Listed after being removed	101
	Status other than Optimal	104
	Status doesn't update after a recovery procedure	106
Power Supplies	Failure detected after replacement	103

Application Search

Table 6-3 lists individual problems for each storage management application, including a group for options common to all applications.

TABLE 6-3 Troubleshooting Entries Organized by Application *(1 of 2)*

Application	Problem	See Details On
Common To Any Application	Can't select some options	101
	"Cannot secure access to LUNs" message	102
	Select Module lists a RAID Module removed from the system	101
	Status doesn't update after a recovery procedure	106
Configuration	Less capacity shows than selected during configuration	97
	List/Locate Drives doesn't work	97
	LUN creation error after deleting all LUNs or using Reset Configuration	98
	No Such Device or Address message is displayed	98
	Number of drives incomplete or wrong during LUN creation	97
	Number of Drives field shows fewer drives than expected	97
	Reset Configuration doesn't work	97
Status	Reconstructing status appears, but no drives replaced	104
	Status remains Reconstructing	105

TABLE 6-3 Troubleshooting Entries Organized by Application (2 of 2)

Application	Problem	See Details On
Recovery	All drives failed in a drive group	105
	Controller mode is Passive, no LUNs owned after replacement	105
	Drive fault lights lit (drives continue to fail)	104
	Drive status other than Optimal	103
	Failed status, but LUN is Optimal	104
	Fault light comes on after replacing failed drive	104
	Failure detected after replacing fan or power supply	103
	LUN status other than Optimal	104
	Missing information in Manual Recovery → Drives screen	105
	Missing information in Manual Recovery → Logical Units screen	105
	Reconstructing status appears, but no drives replaced	104
	Recovery Guru takes a long time	103
	Removed drive, but Recovery Guru doesn't report a failure	103
	Status doesn't update after a recovery procedure	106
	Status other than Optimal	104
Status remains Reconstructing	105	
Maintenance/Tuning	Controller mode is Passive, no LUNs owned after replacement	105
	Firmware upgrade failed	99

Software Search

Table 6-4 lists individual problems by operating system, storage management software, and command line options.

TABLE 6-4 Troubleshooting Entries Organized by Software

Software	Problem	See Details On
Storage Management	“Cannot secure access to LUNs” message	102
	Can’t select some options	101
	Controllers/LUNs not visible	101
	Failure detected after replacing fan or power supply	103
	“Not all files removed” message when uninstalling the software	100
	RAID Module listed after being removed	101
Command Line	Script file commands fail	100
	Battery age doesn’t reset for both controllers	102

Configuration Application

Table 6-5 lists problems you may have as you use options in the Configuration Application.

TABLE 6-5 Configuration Application Changes Troubleshooting (1 of 2)

Number of Drives field (in the Create LUN main screen) show less than the number of drives in the unassigned drive group.

Cause: There may be failed or unresponsive drives in the unassigned drive group. Failed drives are not available for configuration; therefore, they are not displayed in this list.

Less capacity shows than I selected during configuration.

When using five or more drives to create a LUN, you may see a capacity slightly less than you selected during configuration; for example, you see 1.97 GB instead of 2 GB on a RAID 5, 9-drive LUN. This can occur because the capacity you select is based on stripe size, which depends on segment size times the number of drives.

List/Locate Drives → Locate doesn't work.

Action: It is not possible to flash the drive activity lights for a particular drive group if any of the drives has a status other than Optimal. For an explanation of possible drive statuses and recommended action to take, see the Online help.

Cause: Use `Module Profile` to verify that all drives are Optimal and try again. If any of the drives are not Optimal, select `Recovery Guru\Health Check` (in the Recovery application) to correct the problem.

Reset Configuration doesn't work.



Caution: Any time you use Reset Configuration, *you will lose all data on your drives. Only select this option as a last resort* if your configuration is inaccessible or you want to start over. You will need to use `Create LUN` to re-configure your drive groups/LUNs.

Cause: If this software detects any drives as removed or unresponsive, `Reset Configuration` will not work. Also, `Reset Configuration` will not work on an Active/Passive pair. If the selected RAID Module has an Independent Controller configuration, the `Reset Configuration` option is grayed out.

Action: Reboot the system. Use `Module Profile` to verify that all drives are Optimal and that the controller is not in an Independent Controller configuration (neither controller is marked Inaccessible). Try `File → Reset Configuration` again.

Caution: Any time you use `Reset Configuration`, you will lose all data on your drives. Select this option only as a last resort if your configuration is inaccessible or you want to start over. You will need to use `Create LUN` to reconfigure your drive groups/LUNs.

TABLE 6-5 Configuration Application Changes Troubleshooting (2 of 2)

LUN Creation error message is displayed after deleting all LUNs or using File → Reset Configuration.

Cause: Most likely the controller has 64 or 128 MB cache and requires a reset after deleting all LUNs/drive groups before re-creating new LUNs/drive groups.

Action: Turn off power to the affected RAID Module. Turn the power back on and try the LUN creation procedure again.

No Such Device Or Address message is displayed during LUN creation

Cause: Most likely this is an incorrect error message. The LUN creation operation should be completed successfully, although it may take several minutes.

Action: Wait several minutes for the operation to be completed.

Firmware Upgrade

Table 6-6 lists problems you may have while upgrading firmware.

TABLE 6-6 Controller Firmware Upgrade Troubleshooting

Determine which controller firmware version is downloaded without the storage management software installed.

Use a serial or SCSI diagnostic tool to check the controller firmware version currently installed.

Firmware upgrade does not complete successfully.

Cause: This should not happen unless you try to perform some other activity on the module while upgrading controller firmware.

Note: If you are upgrading firmware to a redundant controller pair, the progress bar reaches 50% very quickly after downloading a file to the first controller. However, it may take another couple of minutes to reach 100% if it is downloading to a second controller in the module. Do *not* assume the controller has hung unless the firmware upgrade has not completed after ten minutes or so.

Action:

- To avoid this problem, *wait* for the controller firmware upgrade to be completed before selecting any other option or exiting the `Maintenance/Tuning` application.
- If it occurs, turn off power to the RAID Module and turn it back on; then, immediately try to upgrade the firmware again.

Tip: If you are not upgrading the firmware again immediately, check the firmware version of the module's controllers using `Module Profile`. The controller firmware could be in an unusable state if some files completed the download process before the controller hung. In this case, your module will not perform properly until the firmware is upgraded.

Unable to highlight some controllers for firmware download. (Bug 4163706)

If you selected the controller (especially if it is an independent controller), ignore the unhighlighted status, select the appropriate firmware file for download, and click OK.

General

Table 6-7 lists general problems you could have in all applications.

TABLE 6-7 Troubleshooting Generally Applicable to All Applications (1 of 3)

Controller failed while bringing its alternate Online.

Cause: You have a RAID Module with two controllers, one is Offline and the other is Online (Optimal). When you bring the offline controller online, you could see the alternate controller Fail or go Offline.

Action: Bring the newly failed controller Online using the same procedure.

While uninstalling this software, “not all files were removed” message is displayed.

Cause: If you see this message after performing the uninstall procedure (see page 88), the auto parity check/repair service was probably running. The software has been successfully uninstalled; however, there may be some files that were not removed from the installation directory.

Action: Delete any remaining files from the installation directory, then delete the directory.

A RAID Module I have removed from my system causes long delays or hangs the system and the logical units are not visible to the storage management software (using Options → Manual Recovery → LUNs → Format to format the logical unit).

Cause: Moving a RAID Module from one host to another host can confuse the storage management software, particularly when the original device name for the RAID Module is the same as a RAID Module on the new host. This causes a duplicate entry in the `mnf` file.

Action: In the Configuration application, go to the Module Selection screen, select the RAID module you want to remove, and click Remove. (If you want to add the RAID Module to your system again, return to the Module Selection screen, select the RAID module you want to add, and click Add.) The `mnf` file can also be edited at the command line by running the `lad` utility or any other storage management application to regenerate the file.

Commands run in a batch file fail unexpectedly.

Cause: Utility commands such as `fwutil` or `rdacutil -u` that require a controller reboot may return before the controller is ready to accept commands. If the next command is executed before the controller is ready to accept commands, the controller will return an error status.

Action: Include a delay command in the batch file to allow enough time for the controller to finish its action.

TABLE 6-7 Troubleshooting Generally Applicable to All Applications (2 of 3)

Some controllers/logical units are *not* visible to the storage management software, but *are* visible to the host.

Cause: It is possible that controllers or logical units might *not* be visible to the storage management software, but will remain visible to the operating environment. Any time an operation is being performed that requires exclusive access to the logical units (LUNs), these LUNs may not appear on the screen *except* in the application where the operation was initiated.

The software uses a file (`\program files\Raidmgr\lunlocks` for Windows NT and `/etc/osa/lunlocks` for Solaris) to hide these LUNs from the other applications, so that no other operations can be performed on them until the current operation is complete. For example, if you started a format in the `Recovery` application, these LUNs show a “Formatting” status in `Recovery`, but may not appear in any other application. Operations that require exclusive access include `Delete for LUNs` and `File → Reset Configuration` (Configuration application); `formatting a LUN with Options → Manual Recovery → Logical Units` (Recovery application); and `Firmware Upgrade → Offline method` (Maintenance/Tuning application).

Should the utility/application holding the LUN lock come to an abnormal termination, these LUNs may remain hidden from the other applications.

Action:

1. Wait for the operation to be completed, or perform operations on a different RAID Module.
 2. If you *still* do not see controllers or LUNs that you know exist, do the following:
 - Close all your applications and exit the storage management software completely.
 - In Windows NT, run the `clean.bat -all` script to delete certain `.mnf`, `mutex`, and `lock` files that are associated with RAID Manager and could be hiding information from this software.
- In the Solaris environment, type the following at the system prompt: `rm /etc/osa/lunlocks`.
3. Restart the application where you had the problem and verify that the controller/LUNs are now visible.

A RAID Module is listed that I have removed from my system.

Cause: The storage management software does *not* automatically remove modules from configuration; thus, a module you remove will continue to be listed in the RAID Module Selection box and the Module Selection screen.

Action: Use `Select Module → Remove` *after* physically removing the RAID Module. See the Online Help for the specific procedure to follow.

I cannot select some options.

Cause: Some options are grayed out or are unavailable because:

- The selected RAID Module does not support that option.
- The option cannot be performed for the item you selected.
- The option is not active until you select some item.
- The option is no longer applicable because a maximum has been reached.

Action: Recheck your selection and try again.

For more specific information, see the Procedures section in the *User's Guide* that describes the particular option, or consult Online Help, “Why Are Some Options Grayed Out?”

TABLE 6-7 Troubleshooting Generally Applicable to All Applications (3 of 3)

Battery age did not reset for both controllers.

Cause: When you use the `raidutil` command to reset a battery's age, the command affects only one controller at a time.

Action: Perform the battery reset command (with `raidutil`) for each controller in a RAID Module as needed.

"Cannot secure access to the LUNs" message is displayed (operations won't run for a selected RAID Module).

Cause: Most likely a second application has requested exclusive access to the selected RAID Module when some other application has already secured access. Many operations require exclusive access to the affected drive group/LUNs until its operation is completed (this software "locks" these components to secure this access).

Also, if the affected LUNs are under some other software's control, the storage management software cannot gain exclusive access. Either this message is displayed, or the second request is denied and you see an error message indicating that the module has I/Os occurring or that file systems are present.

Action: Wait for any operation that has secured exclusive access to the LUNs to be completed before performing another operation on the same RAID Module.

Operations requiring exclusive access include: Delete for LUNs and File → Reset Configuration (Configuration); formatting a LUN with Options → Manual Recovery → Logical Units (Recovery); and Firmware Upgrade → Offline method (Maintenance/Tuning).



Caution: If you are using more than one network management station, or if you are using the storage management software on more than one host, use caution when performing the tasks that need exclusive access to ensure that the two hosts do not send conflicting commands to the controllers in the RAID Modules.

Component/module status other than Optimal.

Cause: Statuses other than Optimal can indicate many things and usually warrant attention because the module is *not* operating in a normal condition. The most common causes are:

- At least one drive has failed.
- A drive has been replaced and is reconstructing.
- A logical unit is formatting.
- A controller has been placed offline or has failed.
- A module component had failed, such as a power supply or fan.

Action: For Failed or Offline drives, Dead or Degraded logical units, or Dead controllers (or Offline controllers that you did not place offline), select Recovery Guru/Health Check and follow the step-by-step procedure it provides. For an explanation of the possible drive, LUN, or controller statuses and any recommended action to take, see the Online Help.

Tip: Do not rely only on logical unit (LUN) status information to determine if a recovery procedure is necessary. For example, if you have hot spares configured for a RAID Module and a drive fails, the hot spare takes over for the failed drive. Therefore, you have an Optimal LUN with a failed drive. Depending on how many hot spares you have configured for the module, you can have multiple failed drives and still have an Optimal LUN.

Recovery Guru/Health Check

Table 6-8 lists problems you may have in running Recovery Guru/Health Check or the Manual Recovery Options in the Recovery Application.

TABLE 6-8 Recovery Guru/Health Check Troubleshooting (1 of 4)

Recovery Guru/Health Check **results take a long time to display.**

Cause: Normally you see Recovery Guru/Health Check's results in a few seconds. However, if you have selected All RAID Modules or there are I/O operations running, you might notice a delay. Also, there could be instances where an unresponsive component or other status change affects the controller's ability to provide a result in Recovery Guru/Health Check, although such occurrences are rare.

Action: If you experience long delays in performing Recovery Guru/Health Check, you might try checking one RAID Module at a time or selecting Recovery Guru/Health Check at a time of low system I/O.

Note: A background check occurs at regular intervals for all RAID Modules (results are logged to Message Log); the default setting is five minutes. You can change the frequency of this check by using Options → Log Settings.

Recovery Guru/Health Check **doesn't report a drive failure when I remove a drive.**

If there is no I/O occurring for that drive, Recovery Guru/Health Check reports an Unresponsive Drive. If there is I/O occurring, the controller will fail the drive (and Recovery Guru/Health Check reports this, too).



Caution: You should *never* remove drives from a module unless the controller has marked them as failed. Doing so could result in data loss for the affected logical unit/drive group. If you suspect problems with a drive, it is best to select Recovery Guru/Health Check and follow the instructions provided.

Software detects a failure even after I replaced a fan or power supply (recover from a Module Component Failure).

Cause: The software continues to report the condition as a failure for approximately 10 minutes after replacing a fan or power supply due to the controller's polling interval.

Action: Wait for the controller to poll the module (default is 10 minutes) after performing this recovery procedure before re-selecting Recovery Guru.

Drive status other than Optimal.

Cause: You have a Failed, Offline, or Replaced drive (which is reconstructing), or a logical unit is being formatted. For an explanation of possible drive statuses and the recommended action to take, see the Online Help.

Action: For Failed or Offline drives, select Recovery Guru/Health Check and follow the step-by-step procedures provided. No action is required if the drives are Replaced or the LUN is Reconstructing or Formatting. However, if the drives remain Replaced and the LUN status was Dead, Recovery Guru/Health Check may report the RAID Module as Optimal. If this occurs, you need to manually begin the format process for the LUN/drive group (Options → Manual Recovery → LUNs → Format).

TABLE 6-8 Recovery Guru/Health Check Troubleshooting (2 of 4)

Drives continue to fail (fault lights lit).



Caution: It is possible that a drive channel has failed. A drive channel failure is indicated when all the drives on the same channel are Failed or Unresponsive. Depending how the logical units have been configured across these drives, the status of the logical units may be Dead, Degraded, or Optimal (if hot spare drives are in use).

Action: Select `Recovery Guru/Health Check` and follow the step-by-step procedure given.

Drive fault light came on *after* I replaced a failed drive.

Cause: This light may come on momentarily when a drive in a RAID 1, 3, or 5 LUN begins reconstruction.

Action: Wait a few minutes for the fault light to go off and the drive activity lights to begin flashing steadily. This indicates that reconstruction is occurring. The drive's status changes to Replaced and the logical unit's status changes to Reconstructing.

However, if the fault remains on, select `Recovery Guru/Health Check` and follow the procedure provided.

Failed Drive status appears, but logical unit status is still Optimal.

Cause: A drive on the logical unit has failed and a hot spare has taken over for it.

Note: To see if a hot spare is being used, use `List/Locate Drives` in the `Configuration` application. The hot spare's drive status is either `In Use` or `Standby` (not being used).

Action: Select `Recovery Guru/Health Check` and follow the procedure provided.

Logical unit status other than Optimal.

Cause: You have a Failed drive or a Replaced drive which is reconstructing, or a logical unit is being formatted. For an explanation of possible logical unit statuses and any recommended action to take, see the Online Help.

Action: For Dead or Degraded logical units, select `Recovery Guru/Health Check` and follow the step-by-step procedures it provides for restoring the logical units. However, if the drives remain Replaced and the LUN status was Dead, `Recovery Guru` may report the LUN as Optimal. If this occurs, you need to manually begin the format process for the LUN/drive group (`Options` → `Manual Recovery` → `LUNs` → `Format`).

LUN status changed to Reconstructing, but no drives have been replaced.

Cause: A hot spare has taken over for a failed drive and the data is being reconstructed on it. The logical unit's status returns to Optimal as soon as reconstruction is completed.

TABLE 6-8 Recovery Guru/Health Check Troubleshooting (3 of 4)

LUN status doesn't change from Reconstructing.



Caution: This could occur after a Manual Recovery task is completed, especially LUN Reconstruction, or because data was reconstructed on a hot spare (the hot spare drive becomes In Use, the LUN status changes to Reconstructing, but may not return to Optimal when reconstruction is completed).

Tip: If reconstruction was interrupted on a hot spare drive because another drive failed in the same drive group/LUN, the LUN is probably Dead (with two Failed drives) and you have lost data. You should select Recovery Guru\Health Check and follow the procedure provided to replace the newly failed drive.

Action: Wait for the background monitor to run (default is five minutes) and to update the status, or To update immediately, do *one* of the following:

- Re-select the RAID Module.
- Exit and re-enter the application.

All Drives in a Drive Group fail.

Cause: If *all* the drives in a configured drive group fail and are then physically replaced, Recovery Guru/Health Check will still show the replaced drives as failed. Their status is not upgraded to Replaced, although the LUN status will show Dead LUN.

Action: In this case, follow the Recovery Guru\Health Check procedure to reformat the LUNs in the drive group.

Tip: If you turn the power to the RAID Module off and then on again, the LUNs in the drive group are deleted, and the replaced drives are returned to the unassigned drive group, still failed. Follow the procedure given in Health Check to recreate the deleted LUNs.

Controller mode is Passive and it doesn't own any LUNs after replacing a Failed controller.

Cause: After you use Recovery Guru to replace a failed controller and Options → Manual Recovery → Controller Pairs to place it back Online, the controller is Optimal but in the Passive mode rather than Active. This is most likely to occur for controller B.

Action: With the newly replaced controller Optimal, use Controller Mode → Change To Active/Active (Maintenance/Tuning) to make the controller Active. You can either redistribute drive groups/LUNs during this mode change, or later you can use LUN Balancing (Maintenance/Tuning) to assign specific drive group/LUNs to each active controller.

Information is missing in the Options → Manual Recovery → Drives screen.

Cause: The drives for the selected RAID Module are unassigned (that is, they are not part of a configured drive group). For these drives, there is no LUN, RAID Level, or logical unit status to report. However, you should still see information for the drives' location and status.

Action: Select another module, or use the Configuration application to create logical units using those unassigned drives.

No LUN information appears in the Options → Manual Recovery → Logical Units screen.

TABLE 6-8 Recovery Guru/Health Check Troubleshooting (4 of 4)

Cause: There are no configured logical units for the selected RAID Module (that is, all the drives are unassigned). There is no LUN, drive group, RAID Level, or logical unit status to report.

Action: Select another module, or use the Configuration application to create logical units using those unassigned drives.

Component status isn't updated after a recovery procedure has been performed.

Cause: A configuration change may not be detected yet. For example, a drive is failed, then replaced and its status becomes Replaced, but does not return to Optimal after reconstruction is completed.

Action: Try selecting a different RAID Module, then switching back and re-selecting Options → Manual Recovery, or exit, then reselect the Recovery application.

A Battery Alert is displayed after a controller is replaced or power-cycled.

Cause: Recovery Guru/Health Check has probably returned a false result.

Action: Wait at least 15 minutes, then run Recovery Guru/Health Check again before taking any action on the battery alert.

Replacing Controllers

It is best to use Recovery Guru/Health Check (Recovery Application) to diagnose and correct problems with your RAID Module components. The following procedures are to be used only for the specific conditions described and are *not* generic. Therefore, do *not* use them for replacing any failed controller.



Caution – Be sure to check the README file on this software’s CD-ROM for last minute updates to the “Replacing Controllers” section.

Do *not* use controllers with 2.04.X or 2.05.04 firmware as replacements in a module running 3.X firmware. Instead, use the following minimum firmware levels:

- In SCSI systems, use replacements with a minimum firmware 2.05.06.
- In Fibre Channel systems, use replacements with a minimum 3.01.X.

If you are not certain what firmware version a spare controller has, do *not* use it and contact your local Sun solution center or Sun service provider.

When you cold-swap a controller (replace a controller in a RAID Module while the module is turned off), the World Wide Name (WWN) changes to prevent duplicate WWNs. You must reboot the host system so it can recognize the new controller.

Caution – There is at least one cold-swapping scenario that could cause data corruption. If you have two arrays on the same loop or switch and cold-swap both controllers in one array for the controllers in the other array, or if you swap the entire controller module, you **MUST** reboot the host system. Because they were swapped together, the controller pairs will not change their Node Name. Therefore, unless you reboot the host, the Fibre Channel host adapter will track the controller pairs to the new -- and incorrect -- media.

If you have replaced a failed controller already and experience problems, begin with one of the following procedures as recommended:

- “Problems Bringing the New Controller Online” on page 108.
- “Incompatible Firmware Detected” on page 109.

Problems Bringing the New Controller Online

You have replaced a controller and either your system crashed or you saw a message while trying to bring the new controller Online. The message told you to check your controller connections and to consult this section if there are still problems.

Problem Summary

One problem that could be preventing you from bringing the controller back online is that the new replacement controller has 2.05.X firmware while the remaining operational controller in your RAID Module has 2.04.X or 3.X firmware.



Caution – If your system crashed and is using Fibre Channel controllers running 3.X firmware, your new replacement controller must have 3.01.X firmware at a minimum. If the controller has an earlier version, this is probably what caused your system to crash. Obtain a replacement controller with 3.X firmware and begin the recovery procedure again.

4. **Exit all storage management applications.**
5. **Re-start the Recovery Application and make sure that the affected RAID Module is selected.**
6. **Select Manual Recovery → Controller Pairs, highlight the controller that is Offline, and select Place Online.**

Once the controller is placed Online, you see an incompatible firmware detected message. Refer to the next section, “Incompatible Firmware Detected” on page 109.

Incompatible Firmware Detected

You replaced a controller and saw a message after the new controller was brought Online telling you that incompatible firmware has been detected and to consult this section.

Problem Summary

The correct procedure for upgrading the controller firmware depends on the controller firmware versions of both controllers and on the controller slot location of the new replacement controller. Use the following steps to determine the correct procedure to use.

- 1. Using the Recovery Application, select Module Profile → Controllers and determine the following:**
 - Record the controller name/ID for both controllers. Be sure to note which is currently controller A and which is controller B. You will need this information to identify the controllers during this procedure.
 - Record the firmware version of both controllers. Be sure to note which version applies to the old controller and which to the new, replaced controller. You will need this information to determine the correct procedure to follow for upgrading the controller firmware.

2. Use TABLE 6-9 to determine how to proceed.

TABLE 6-9 Determining Which Upgrade Procedure to Follow

Controller Firmware Version on Current Controller	Controller Firmware Version on Replacement Controller	Action to Take
2.04.X	2.04.X, 2.05.X	<p>Download the 2.04.X firmware to the replaced controller using the normal procedure (Maintenance/Tuning → Firmware Upgrade → Offline method). This will return your RAID module to its original state. Consult the <i>Sun StorEdge RAID Manager User's Guide</i> or Online Help for further details.</p> <p>Note: You may want to upgrade the 2.04.X firmware in the current controller to match the firmware in the replacement controller (upgrading your system to the latest version is usually recommended). If you decide to upgrade, you may need to upgrade to an intermediate level of firmware first. Use Table A-4 on page 121 to determine if an intermediate upgrade is required.</p>
2.05.X	2.04.X, 2.05.X	<p>Download the 2.05.X firmware to the replaced controller using the normal procedure (Maintenance/Tuning → Firmware Upgrade → Offline method). This will return your RAID module to its original state. Consult the <i>Sun StorEdge RAID Manager User's Guide</i> or Online Help for further details.</p> <p>Note: You may want to upgrade the 2.05.X firmware in the current controller to match the firmware in the replacement controller (upgrading your system to the latest version is usually recommended).</p>

TABLE 6-9 Determining Which Upgrade Procedure to Follow

Controller Firmware Version on Current Controller	Controller Firmware Version on Replacement Controller	Action to Take
3.00.X or later	2.04.X, 2.05.04	<p>Caution: Do <i>not</i> use these versions as replacement controllers in a system running 3.X. Obtain a replacement controller with the minimum recommended firmware:</p> <ul style="list-style-type: none"> • In SCSI systems, use replacements with a minimum firmware 2.05.06. • In Fibre Channel systems, use replacements with a minimum 3.01.X. <p>If you are not certain what firmware version a spare controller has, do not use it. Obtain spare controllers from your local solution center.</p>
	2.05.00 through 2.05.03	<ul style="list-style-type: none"> • For SCSI systems, continue with Step 3 on page 112. • For Fibre Channel systems, do <i>not</i> use these versions as replacement controllers. Use replacements with a minimum 3.01.X. If you are not certain what firmware version a spare controller has, do not use it. Obtain spare controllers from your local solution center.
	2.05.05 or later	<ul style="list-style-type: none"> • For SCSI systems, select <i>only</i> the replaced controller to upgrade the firmware using the normal procedure (Maintenance/Tuning → Firmware Upgrade → Offline method). Consult the <i>Sun StorEdge RAID Manager User's Guide</i> or Online Help for further details. • For Fibre Channel systems, do <i>not</i> use these versions as replacement controllers. Use replacements with a minimum 3.01.X. If you are not certain what firmware version a spare controller has, do not use it. Obtain spare controllers from your local solution center.

3. Which controller slot location is the new, replaced controller placed in (the new controller has a firmware version of 2.05.00 through 2.05.03)?

In Slot A	In Slot B
<p>You <i>must</i> use the procedure on page 113.</p> <p>You may want to call your local solution center or Sun service provider for additional support with this procedure.</p>	<p>Select <i>only</i> the replaced controller to upgrade the firmware using the normal procedure (Maintenance/Tuning → Firmware Upgrade → Offline method). Consult the <i>Sun StorEdge RAID Manager User's Guide</i> or Online Help for further details.</p> <p>Note: You may need to upgrade to an intermediate level of firmware first. Use Table A-4 on page 121 to determine if an intermediate upgrade is required.</p>

Upgrading Firmware from 2.05.00 Through 2.05.03 to 3.X for a Replaced Controller In Slot A



Caution – This procedure is very difficult and takes a long time. You may want to contact your local solution center for additional support.

Use this procedure *only* to upgrade to controller firmware 3.01.X in a SCSI system that was originally running 3.00.X or later. The Firmware Upgrade option (Maintenance/Tuning Application) does *not* allow you to downgrade from controller firmware 3.X.

You *must* use this procedure to upgrade the controller firmware on the replaced controller if it has controller firmware versions 2.05.00 through 2.05.03. Trying to upgrade the firmware on the controller while it remains in slot A can cause the controller to panic and the firmware upgrade to fail.

1. **Stop all I/Os to the affected RAID Module.**
2. **Exit *all* storage management applications.**
3. **One at a time, pull both controllers out of their slots and label them with their controller name/IDs (which you recorded from Module Profile → Controllers in Step 1 on page 109).**

Tip – Make sure at least 1 minute has elapsed before inserting the controller indicated in Step 4.

4. **Insert the controller that has firmware 3.X (controller B) firmly into controller slot A of the RAID Module. Do NOT insert the second controller until instructed to do so later in this procedure!**

Make sure at least 1 minute has elapsed before continuing with Step 5.

5. **From the command line, use the `lad` utility to determine when the storage management software sees this controller.**

A list of devices is displayed. This could take several minutes. Look for the controller name/ID for the controller now in slot A in this list. When it appears, continue with Step 6.

6. **From the command line, use the `rdacutil` utility to place this controller in the Active mode. For example, type:**

```
rdacutil -m 1 <controller name/ID>
```

where <controller name/ID> is the name that the `lad` utility now displays.

7. **Insert the new replacement controller (that has controller firmware 2.5.X and was controller A) firmly into controller slot B of the RAID Module.**

Make sure at least 1 minute has elapsed before continuing with Step 8.

8. **Exit all storage management applications.**
9. **Re-start the software, select the Maintenance/Tuning Application, and highlight the correct RAID Module.**

10. **Select Firmware Upgrade → Offline.**

You must use the Offline procedure in order to select a single controller for downloading firmware.

11. **Highlight the controller in slot B (it shows firmware level 2.5.X downloaded currently), and highlight the appropriate firmware files in the Compatible Files/ Versions list.**

Note – Because you are upgrading to firmware level 3.X, you may need to upgrade to an intermediate level first. Use Table A-4 on page 121 to determine if an intermediate upgrade is required.

12. **Select OK to begin the upgrade. Wait for this procedure to finish before continuing to Step 13 or using the Firmware Upgrade option again if intermediate upgrades are required.**

13. **Select Controller Mode. The controllers should appear as an Active/Passive pair.**

Note – You may want to use Controller Mode to change the pair to Active/Active. This option enables you to balance drive group/LUNs between the controller, or you can use LUN Balancing later to change the LUN assignment.

Specifications

This appendix describes the configuration specifications for this software.

- Hardware Specifications—page 116
- Required Patches—page 119
- Controller Firmware Upgrade Notes—page 121

Hardware Specifications

Host-RAID Module Configurations

The following host-RAID Module configurations are supported:

- **Single-Host Configuration.** One host machine has two host adapters, each connected to one of the controllers in the RAID Module.
- **Independent Controller Configuration.** Two host machines are connected to a dual-controller RAID Module. One host machine is connected by a SCSI host adapter to one controller, and a second host machine is connected by another host adapter to the other controller.
- **Multi-Host Configuration.** A pair of server-host adapter systems is connected to one or more RAID Modules.

Note – Multi-host configurations are only supported with Sun™ Cluster 2.x software.

- **Fibre Channel Configuration.** Any of the above configurations can be used with Fibre Channel controllers instead of SCSI controllers, depending on the Solaris operating environment version and installed patches.

For an explanation of a RAID Module, see the “Common Definitions” section in the *Sun Storage RAID Manager User’s Guide* or the Online Help glossary. For more information on the types of Host-RAID Module configurations supported by the storage management software, see “RAID Module Configurations” in the *Sun Storage RAID Manager User’s Guide*.

Host Systems

TABLE A-1 provides a list of platforms supported for the Sun StorEdge A1000, A3000, and A3500 systems at the time this manual was published. Refer to the *Sun StorEdge RAID Manager Release Notes* for updates to this list.

TABLE A-1 Supported Platforms for Sun StorEdge A1000, A3000, and A3500

Sun StorEdge A1000	Sun StorEdge A3000	Sun StorEdge A3500
Sun Ultra 1	Ultra E450	Sun Enterprise 2
Sun Ultra 5 S	Ultra E3000	Sun Enterprise 250
Sun Ultra 10	Ultra E4000	Sun Enterprise 450
Sun Ultra 30	Ultra E5000	Sun Enterprise 3000/3500
Ultra E250	Ultra E6000	Sun Enterprise 4000/4500
Ultra E450	Ultra E10000	Sun Enterprise 5000/5500
Ultra E3000		Sun Enterprise 6000/6500
Ultra E4000		Sun Enterprise 10000
Ultra E5000		
Ultra E6000		

Host Adapters

Refer to the documentation that was shipped with your host adapter card for instructions on installing the SCSI or PCI host adapter and connecting it to your host machine.

SCSI Host Adapters

TABLE A-2 lists the SCSI host adapters that have been tested with the RAID Manager software:

TABLE A-2 Supported SCSI Host Adapters

Host Adapter	Product Description	Part Number
Sbus	Differential Fast-Wide Intelligent SCSI-2 (DWIS)	X1062A
Sbus	Ultra Differential Fast-Wide SCSI (UDWIS)	X1065A
PCI	Dual-Channel UltraSCSI Host Adapter PCI	X6541A

Fibre Channel Host Adapters

TABLE A-3 lists the Fibre Channel host adapters that have been tested with the RAID Manager software:

TABLE A-3 Supported Fibre Channel Host Adapters

Host Adapter	Product Description	Part Number
Sbus	Sun StorEdge Sbus FC-100 Host Adapter	X6730A
PCI	Sun StorEdge PCI FC-100 Host Adapter	X6729A

Caution: Do not use the Sbus HBA card with a part number of 501-3060.

Boot Device Host Adapters

At this time, Sun supports limited boot device host adapters only for SCSI controllers. Contact your local Sun solution center or Sun service provider for more information about this feature.

Fibre Channel Hubs

The Sun StorEdge FC-100 Hub (part number X6732A) has been tested with the RAID Manager software.

Fibre Channel Fabric Switches

At this time, Sun does not support the Fibre Channel fabric switches.

Required Patches

Software patches for the Solaris operating environment are available to ensure proper operation of the storage management software in the Solaris operating environment. Make sure that all required patches are installed properly *before* installing the Sun StorEdge RAID Manager software.

For a list of the patches (including patch ID numbers) required to use the Sun StorEdge RAID Manager product in a Solaris operating environment, refer to the *Sun StorEdge RAID Manager Release Notes*.

Note – You must reboot the operating environment with the `boot` command for the changes to take effect. Therefore, make sure that other users are not on the system when installing patches.

▼ To Install Required Patches

Perform the following steps *before* installing the Sun StorEdge RAID Manager software:

1. Determine the Solaris version you have by using one of the following methods.

- Type the following at the system prompt:

```
uname -a
```

The version is specified as 5.6 (for Solaris 2.6 software) or 5.7 (for Solaris 7 software).

Or

- Type the following at the system prompt:

```
cat /etc/release
```

The `/etc/release` file includes version information as shown in the following example.

```
Solaris 2.6 5/98 s297s_hw3smccServer_09 SPARC
Copyright 1998 Sun Microsystems, Inc. All Rights Reserved.
Assembled on 24 April 1998
```

If the `/etc/release` file does not exist, your system is running a version earlier than Solaris 2.6 5/98.

2. Install the correct patch or patches (for your version of Solaris software) on your host system.

For a list of the patches (including patch ID numbers) required to use the Sun StorEdge RAID Manager product in your Solaris operating environment, refer to the *Sun StorEdge RAID Manager Release Notes*.

Note – For the Solaris 2.6 operating environment, you have the option of installing the required patches as described in the *Sun StorEdge RAID Manager Release Notes* or downloading and installing the Solaris 2.6 Recommended Patch Cluster.

3. After installing the appropriate patches, reboot the Solaris system for the changes to take effect by typing:

```
boot
```

Controller Firmware Upgrade Notes

If you are upgrading to firmware level 3.01.X, you may need to upgrade to an intermediate level first. Use TABLE A-4 to determine if an intermediate upgrade is required.

Tip – If you are upgrading from any 2.04.X version to 3.01.X, do *not* skip the recommended intermediate upgrade using 2.05.06. Doing so will cause the upgrade to fail after loading the `appware` file, and the controller will hang.

TABLE A-4 Controller Firmware Upgrade

If you have firmware version	Upgrade
2.4.1d	<ul style="list-style-type: none">• to 2.4.4.1• then to 2.5.6.32• then to 3.01.02.xx
2.4.4.1 through 2.5.2.32	<ul style="list-style-type: none">• to 2.5.6.32• then to 3.01.02.xx
2.5.6.32	<ul style="list-style-type: none">• directly to 3.01.02.xx

Note – Refer to the *Sun StorEdge RAID Manager Release Notes* for updates on controller firmware levels.

- With firmware level 3.X and higher, the Fibre Channel code is included in the firmware (`appware`) file.
- Note that controller firmware level 3.01.X or higher is required for some storage management features documented in the *Sun StorEdge RAID Manager User's Guide*. This means that the features are not available on controllers that do not support firmware level 3.01.X.
- The storage management software does *NOT* allow you to downgrade controller firmware from 3.01.X to 2.X. If you attempt to begin the downgrade process from 3.01.X to 2.X by downloading one file at a time from the Path line, the `bootware` file download will fail and the controller will be inaccessible. You will have to contact your local Sun solution center or Sun service provider to recover the module.

- Also, if you are upgrading a controller that has ever had a 2.04.X version to 3.01.X, any configured drive groups that are using full capacity (do *not* have at least 38 MB remaining space) will *not* support the new storage management features (such as the Modify Group/LUN options in the Configuration Application). If this occurs and you wish to support these features, perform the procedure in “Supporting The Modify Group/LUN Options” on page 122.

Firmware Autosynch

The storage management software includes an optional NVSRAM entry that automatically synchronizes controller firmware versions on dual controllers. For more information about this feature, consult the *Sun StorEdge RAID Manager User's Guide* or contact your local Sun solution center or Sun service provider.

Note – The controller autosynch feature requires the setting of two NVSRAM bits for it to work. At the time this manual was published, this feature was not supported by Sun.

Supporting The Modify Group/LUN Options

After you have upgraded the controller firmware to 3.01.X, it is possible that drive groups that did not have remaining space do *not* support the dynamic configuration options in the Configuration Application → Modify Group/LUN. If you want the drive group to support these options, do the following:

1. **Back up data on the affected drive group.**

Note – You may also want to use File → Save Module Profile for a snapshot of the configuration information for the affected drive group/LUNs for later reference.

2. **Select Configuration → Delete and highlight all the LUNs for the affected drive group to delete. Select OK. Select OK again at the confirmation screen.**
3. **Turn the power off to the RAID Module, and then turn the power back on.**
This creates the necessary space on the drive group.
4. **Select Configuration → Create LUN to recreate the drive group and its LUNs.**
5. **Restore the data from backup.**

Reference Material

This appendix includes the following reference material:

- NVRAM Settings—page 123
- `rmparams` File Listing—page 124
- `rmscript` File Listing—page 128
- `man` Pages—page 131

NVRAM Settings

During installation of the software, the `nvutil` program (which is part of the installation package) will automatically check and, if necessary, change any NVRAM settings on the controllers in the RAID Modules necessary to run Sun StorEdge RAID Manager. Thus, in most cases, you should have no concerns about NVRAM settings and will need to read no further in this section.

However, if you have a RAID Module that has two controllers and you are not seeing both controllers using the `Module Profile` option in any of the applications (such as Configuration or Status), or you are seeing unusual behavior, you may need to change some NVRAM settings. You can use the command line `nvutil` program for this purpose. View the `nvutil` man page for on-line usage instructions.

Note – If you make any changes with `nvutil`, reboot the system. If you do not want to shut down your system, cycling power on the RAID Module without a reboot is sufficient *unless* you have changed the values at offset 0x0011 or 0x0024.

rmparams File Listing

The following is a complete listing of the `rmparams` file. Note that some values/entries may not be the same as the file on your system.

Note – The `rmparams` man page documents the parameters that are considered safe for users to modify. All other parameters should be left alone.



Caution – Because of the critical nature of the `rmparams` file, a backup copy of this file has been installed in the `/usr/lib/osa/` directory and is named `rmparams.install`. If the `/etc/osa/rmparams` file becomes corrupted or missing, copy this file to the `/etc/osa` directory to resume normal operation. If you make any changes to this file directly or use the options in the GUI that write to this file (such as log settings, auto parity settings, and so on), always copy the new version of the file to the `/etc/osa` directory.

```
# System Parameters
System_AltDevDirRoot=/dev/osa/dev/rdsk
System_LunlocksDirPath=/etc/osa/lunlocks
System_MaxLunsPerController=8
System_MaxControllers=32
System_NamefileDirPath=/etc/osa/mnf
System_RmHomeDirectory=/usr/lib/osa
System_NametempDirPath=/etc/osa/nametmp
System_TimestampDirPath=/etc/osa/timestamps
System_RmBootHomeDirectory=/usr/lib/osa/bin
System_RmFirmwareDirectory=fw
System_MaxHostAdapters=32
System_MaxSCSIid=15
System_MaxLunsPerHostAdapter=255
System_SafePassThroughLun=0
System_LunReDistribution=TRUE
System_NvsramDefDirPath=/usr/lib/osa/fw/
System_RdacBlkDirectory=/dev/osa/dev/dsk
System_RdacChrDirectory=/dev/osa/dev/rdsk
System_UnprotectedOfflineUpgradeAllowed=FALSE
System_DefaultModuleSelect=FALSE
System_CreateLunsExactSize=TRUE

# Array Monitor Parameters
Monitor_PollInterval=5
Monitor_ParityTime=02:00
```



```

Monitor_PchkEnabled=1
Monitor_ParityName=bin/parityck -aqf
Monitor_ParityDay=Sunday

# Graphical Viewer Parameters
Viewer_Log_Opened          = rmlog.log
Viewer_Controller= All DiskArrays
Viewer_Select1= NONE
Viewer_Inequality1= NONE
Viewer_Conjunction1= NONE
Viewer_Phrase1= NONE
Viewer_Select2= NONE
Viewer_Inequality2= NONE
Viewer_Conjunction2= NONE
Viewer_Phrase2= NONE
Viewer_LogSize=40

Help_Files_Directory      = help/
Help_Files_GlossaryName   = help/glossary.txt

# Parity Assurance Parameters
# Limits for Parity_Amount is 1000 to 32767
# Limits for Parity_Delay is 0 to 10
Parity_Amount=32767
Parity_Delay=0
Parity_RepairBadBlock=TRUE

# Notification Parameters
Notify_LogName=rmlog.log
Notify_LogEnabled=1
Notify_ScriptName=/usr/lib/osa/bin/rmscript

# The System_CatalogLanguage parameter corresponds to
# the set ID in the RAID Manager message catalog.
# Supporting a new language involves adding a new set
# to the messages.cat file and setting
# the System_CatalogLanguage parameter to the new set ID.
# The currently defined sets are:
#
#           Set ID Language
#           _____
#           101     ENGLISH
#
# The RAID Manager reserves sets 101 and above for
# its use; sets 1-100 are available for user
# customization.
System_CatalogLanguage=101

```

```

# RDAC driver/Resolution Daemon Failover parameters
Rdac_SupportDisabled=FALSE
Rdac_SinglePathSupportDisabled=FALSE
Rdac_HotAddDisabled=PARTIAL
Rdac_HotAddIDs:4:5:
Rdac_NativeScsiDrivers:sd:ssd:
Rdac_ExposeDualPath=FALSE
Rdac_RetryCount=7
Rdac_OriginalPathRetryCount=0
Rdac_NoAltOffline=FALSE
Rdac_Forced_Quiescence_Flag=TRUE
Rdac_Fail_Flag=TRUE
Rdac_Quiescence_Timeout=5
Rdac_Clear_Path_Timeout=5
Rdac_Ioctl_Retry_Flag=TRUE
Rdac_NoReconfig=FALSE
Rdac_DR_Timeout=5

# SNMP Trap Notification Daemon Definitions
SNMP_Number_Of_Target_NMS=1
SNMP_Target_IP_Address=127.0.0.1
SNMP_Target_IP_Address_2=127.0.0.1
SNMP_Target_IP_Address_3=127.0.0.1
SNMP_Target_IP_Address_4=127.0.0.1
SNMP_Target_IP_Address_5=127.0.0.1
SNMP_Target_IP_Address_6=127.0.0.1
SNMP_Target_IP_Address_7=127.0.0.1
SNMP_Target_IP_Address_8=127.0.0.1
SNMP_Community_Name=public
SNMP_Community_Name_2=public
SNMP_Community_Name_3=public
SNMP_Community_Name_4=public
SNMP_Community_Name_5=public
SNMP_Community_Name_6=public
SNMP_Community_Name_7=public
SNMP_Community_Name_8=public
SNMP_Action_Number=0
#if the snmp action number is 0 no notifications are sent
#if the snmp action number is 1 SNMP version one trap are sent
#if the snmp action number is 2 all relevent data is written
#to the file trap.dat

```

```
#####  
#*** IDENTIFICATION ***  
#####  
#  
# Name:          rmparams  
# Title:         RAID Manager Parameters File  
# Version:       (see bill-of-materials)  
# Revision:      (see bill-of-materials)  
# Update Date:  (see bill-of-materials)  
# Programmer:   rmj  
# Documents:  
#  
#  
# Description:  
# The RAID Manager Parameters File holds runtime parameters  
# for the RAID Manager. The RAID Manager programs access  
# these values via the GetParam and PutParam interfaces  
# (params.c). This scheme provides some control over  
# RAID Manager behavior without use of command line options  
# or program recompilation.  
#  
#####  
#
```

rmscript File Listing

The following is a complete listing of the `rmscript` file. Note that some values and entries may not be the same as the file on your system.



Caution – The last line in the `rmscript` file must *always* be `rm $1`.

```
#!/bin/sh
#*****
#
# NAME:          %name%
# SUMMARY:      Initial RAID Manager event notification script for
#               Unix systems.
# COMPONENT:    %subsystem%
# VERSION:      %version%
# UPDATE DATE:  %date_modified: %
#
# CONTACTS:
#   Originator: jgatica
#   Owner:      ?
#   Backup:     ?
#   Updater:    %created_by:    %
#
#               Copyright 1995, 1996, 1997 by Symbios Logic Inc.
#
# DESCRIPTION:
# This script is called by the RAID Manager application or daemon
# every time a new event has been detected. The application
# creates an event record and saves it in a file whose name is
# passed as the first argument to this script.
#
# After initial installation, users may change this script to add
# or remove features, such as mailing the superuser account, etc.
# However, this script should always call putplog to update the
# proprietary log (disabling of this can be done via the parameter
# file), and it must delete the event file when it is done with it.
#
# NOTES:
#
# REFERENCE:
# 1. PIP0003C.DOC, Source Code Integrity Measures
```

```

#
#
# CODING STANDARD WAIVERS:
#
#
#*****

PATH=$PATH:/etc/raid/bin:/etc/raid/lib
export PATH
# Add the event to the proprietary log
putplog $1

# Add the event to the syslog
EVTYPE='cut -d~ -f6 $1'
if [ EVTYPE != 30 ]
then
(case $EVTYPE in
#     An AEN event
    00) awk -F~ 'NF > 0 { printf "AEN event Host=%s Ctrl=%s
Dev=%s\n ASC=%s ASCQ=%s FRU=%s LUN=%s LUN Stat=%s\n
Sense=%s", $1, $2, $3, substr($7,1,2), substr($7,3,2),
$8, $9, $10, $11 }' < $1;;

#
#     Mode Page events are ignored for now
    10) ;;

#
#     Parity event
    20) awk -F~ 'NF > 0 { printf "Parity event Host=%s Ctrl=%s
Dev=%s\n Start Blk=%s End Blk=%s
# Blks=%s LUN=%s ", $1, $2, $3, $7, $8, $9, $10 }' < $1;;
#
#     Text events are ignored for now
    90) ;;

#
esac) | ( if [ -x "/usr/ucb/logger" ]
then
    /usr/ucb/logger -t raid -p user.err
elif [ -x "/usr/bin/logger" ]
then
    /usr/bin/logger -t raid -p user.err
fi
)

# Mail the superuser that an event has occurred
(awk -F~ 'NF > 0 { printf "An array event has been detected on
Controller %s \n Device %s at Host %s - Time %s %s\n",
$2, $3, $1, $4, $5 }' < $1; echo "\nGo to the Message Log
in the Status Application for details" ) | mailx -s "raid Event" root

```

```

# If a network is available, does resolv.conf exist and is non-zero?
if [ -s "/etc/resolv.conf" ]
then
case $EVTYPE in
00) cCode="\`cut -d~ -f7 $1`"
cCode="\`echo 0000$cCode`";;
20)cCode="\`cut -d~ -f11 $1`";;
90)cCode="\`cut -d~ -f11 $1`";;
esac
ctrlName="\`cut -d~ -f2 $1`"
hostName="\`cut -d ~ -f1 $1`"
if [ -x "/usr/bin/getent" ]
then
hostIP="\`getent hosts $hostName | awk '/^[0-9][0-9]*[.]/ {print $1}`"
else
hostIP="\`nslookup $hostName | grep Address | tail -1 | awk
'{ print $2 }`"
fi
trapctl $cCode $ctrlName $hostIP $hostName
fi
fi
# Delete the event file (needed since arraymon does not do this)
rm $1

```

man Pages

The following man pages provide supplementary information for disk array management and administration.

- `arraymon`
- `drivutil`
- `fwutil`
- `genscsiconf`
- `healthck`
- `hot_add`
- `lad`
- `logutil`
- `nvutil`
- `parityck`
- `perfutil`
- `raidcode`
- `raidutil`
- `rdac`
- `rdac_address`
- `rdac_disks`
- `rdacutil`
- `rdaemon`
- `rdriver`
- `rm6`
- `rmevent`
- `rmparms`
- `rmscript`
- `storutil`
- `symconf`

Some tasks are carried out automatically by daemon processes that run from system startup to system shutdown. There are, however, command line utilities that enable you to embed customized and interactive operations.

For an overview of the Sun StorEdge RAID Manager graphical user interface, command line programs, daemon programs, driver modules, and customizable elements, see the `rm6` man page.

Index

NUMERICS

- 2.5.3 controller firmware, upgrading, 113
- 32 LUN support, 36
 - genscsiconf script and, 37
 - patches required, 36
 - rmparams file
 - modifying, 36
 - parameter, 69

A

- adding RAID modules, 87
- administrator privileges
 - when required, 40
- appware file
 - downloading, 7
- arbitrated loop physical address, 38
- arraymon
 - stopping and restarting, 81
 - see also background monitor
- auto parity check/repair
 - changing time for, 59
 - described, 59

B

- background monitor, 81
 - see also arraymon
- Batch file
 - delay command, 100

- fails unexpectedly, 100
- Battery age reset, 102
 - troubleshooting, 102
- battery age reset restriction, 7
- Battery Alert message, 106
- battery management, 4
- Blank screen
 - manual recovery
 - drives, 105
 - logical units, 105
- boot device
 - dump/swap device and, 6
 - host adapters supported, 118
 - LUN 0 and, 80
 - RAID module as, 10
 - reset configuration and, 80
- boot -r, 37
- bootware file
 - downloading requirements, 7
- bringing replaced controller online, 108
- Brocade switches, 118

C

- cables
 - checking, 11
- cache parameters
 - changing, 62
- Cannot secure access to LUNs message, 102

- Capacity
 - less than expected, 97
- changes to support RAID Manager, 12
- Channel failure, 104
- checking
 - cable connections, 11
 - hardware, 11
 - hardware and software, 9
 - module status, 48
- clean.bat script
 - when to use, 101
- Command line commands
 - fwutil, 100
 - raidutil, 102
 - rdacutil, 100
- command line utilities
 - lad, 7
 - man pages for, 86
 - raidutil -R, 7
- Component failures
 - unexpected, 103
- Component status
 - unexpected, 106
- Configuration
 - resetting, 97
- configuration
 - adding RAID modules, 87
 - changing parameters, 59
 - determining
 - changes, 58
 - controller firmware version, 44
 - current setup, 52
 - fibre channel support, 116
 - host-RAID module types, 116
 - host-RAID Module types supported, 116
 - Modify Group/LUN options support, 122
- Configuration application
 - List/Locate, Locate won't work, 97
 - main screen
 - defined, 52
 - illustrated, 53
 - reset won't work, 97
 - starting, 52
 - supporting the Modify Drive Group/LUNs
 - option, 122
 - troubleshooting, 97

- Controllers
 - mode
 - passive after replacing, 105
 - not Active after replacing, 105
 - not visible, 101
 - resetting battery age, 102
 - troubleshooting, 100
 - controllers
 - balancing LUNs, 62
 - can't bring online, 108
 - firmware mismatch, 109
 - firmware upgrade versions, 121
 - incompatible software replacing controllers
 - firmware mismatch or incompatible software, 109
 - lock-up bringing back online, 8
 - mode
 - changing, 59
 - names of, 78
 - replacing notes, 107
 - restrictions on replacements, 6
 - setting loop IDs, 38
 - upgrading firmware, 45
 - upgrading firmware in slot A, 113
 - see also firmware
 - creating logical units
 - troubleshooting, 79

D

- daemons
 - arraymon
 - starting, 82
 - stopping, 81
 - RDAC, 83
 - starting, 29
 - stopping, 85
- dead LUNs
 - formatting after failure, 8
 - resetting bus and, 7
 - system panic and, 8
- deleting logical units
 - troubleshooting, 80
- device name
 - controller, 38
 - defined, 78
 - illustrated, 78

- drive groups
 - changing capacity, 61
- drivers
 - RDAC, 28, 83
- Drives
 - failed, 97
 - failures
 - all in drive group, 105
 - keep failing, 104
 - fault light on, 104
 - number for drive group
 - unexpected, 97
 - removing, 103
 - Recovery guru, 103
 - status
 - non-optimal, 103
 - unresponsive, 97, 103
- drives
 - locating, 57
- dump/swap device, 6
- dynamic expansion capacity, 60, 61
 - firmware required, 4
 - see also Modify Group/LUN options

E

- editing module name and comments, 42, 43
- enhancements, 3, 4
- error messages
 - see messages
- Exclusive access, 101, 102

F

- Failed drives, 97
 - all in drive group, 105
- Fans
 - replacing, 103
- Fault light
 - drives, 104
- features
 - new, 3, 4
- Fibre Channel
 - Solaris 7, 116

- fibre channel, 4, 11
 - configurations supported, 116
 - host adapters, 118
 - hubs supported, 118
 - loop IDs, 38
 - switches supported, 118
- Files
 - batch, failed, 100
 - clean.bat, 101
 - lunlocks, 101
- files
 - rmparams
 - listing, 124
 - see command line utilities
 - see also man pages
 - see also rmparams
 - see also rmparams file
 - see also rmscript
- Firmware
 - upgrading
 - unsuccessful, 99
- firmware
 - autosynch, 122
 - checking version, 44
 - intermediate upgrade versions, 121
 - mismatch detected, 109
 - required, 60, 61, 121
 - supporting Modify Group/LUN options, 122
 - upgrading, 45
 - required, 9
 - restrictions, 7
 - troubleshooting, 99
 - versions, 121
 - upgrading on slot A, 113
- fonts required, 41
- fwutil command
 - restriction, 100
 - see also Command line commands

G

- genscsiconf script, 37
- graphics card, 9

H

hardware

- checking, 11
- fibre channel hubs, 118
- fibre channel switches, 118
- host systems, 117
- requirements, 9
- specifications, 116

Health Check

- running a, 48

Health check

- how long it takes, 103
- see also Recovery Guru

host adapter

- boot device and, 118
- fibre channel, 118
- logical unit limits, 36, 79
- LUN limit per, 79
- required hardware, 118
- SCSI, 117, 118
- Symbios, 117

host systems, 117

host-RAID module configuration types

- defined, 116

host-side ID, 11

Hot spare

- in use, 104
- logical unit status and, 104
- troubleshooting, 105

hot spare

- described, 59

hot_add script, 85, 87

hubs (fibre channel), 118

- Vixel, 118

I

identifying module configuration, 52

incompatible software detected, 109

independent controller configuration, 4

- defined, 116
- indicating, 42

installation

- before beginning, 9
- No Such Device message displayed, 6
- remove package, 32, 88

starting, 5

verification, 30

Installation and Support Guide

description, 2

L

List/Locate Drives

- locate won't work, 97

locating solutions for problems, 90

Logical unit

- cannot secure access message, 102
- capacity
 - less than expected, 97
 - not visible to software, 101
- parameters, 97
- status
 - non-optimal, 102, 104
 - remains at Reconstructing, 105
 - shows Reconstructing, 104

logical unit

- adding to operating system, 64, 79
- balancing, 62
- changing
 - cache parameters, 62
 - capacity, 60
 - drive group capacity, 61
 - parameters, 59
 - reconstruction rate, 62
 - segment size, 61
- creating, 79
- deleting, 80
- limits
 - per host adapter, 36, 69, 79
 - per module, 79
- names of, 78
- partitions, 79
- RAID level
 - changing, 60
 - reboot required, 79, 80
 - removing Veritas control of, 82
 - setting number of, 36

loop IDs, 38

LUN 0

- reset configuration and, 80

lunlocks file, 101

M

- man pages, 86
 - can't access, 86
 - locations of, 86
 - overview, 131
- Manual recovery
 - drives
 - blank screen, 105
 - logical units
 - blank screen, 105
- message log, 81
- Messages
 - cannot secure access to LUNs, 102
 - not all files removed, 100
- messages
 - Battery Alert, 106
 - non-optimal Health Check results, 48
 - see also trap messages
- MIB file, 72
- mismatch firmware detected, 109
- Modify Group/LUN options, 60, 61
 - supporting with 3.00.X firmware, 122
- module names
 - defined, 78
 - restrictions, 6
- module profile
 - main screen illustrated, 56
- module selection screen, 4, 42, 43
 - disabling, 68
- Module status
 - non-optimal, 102
 - unexpected, 106
- monitoring interval
 - changing, 59
- mouse, 9
- multi-host configuration, 4
- multi-initiator configuration
 - defined, 116
 - support for, 116

N

- names
 - module, 78

NMS

- see SNMP
- No Such Device or Address message, 6
- Not all files removed message during
 - uninstall, 100
- notification
 - see rmscript
 - see SNMP
- Number of drives
 - limitation, 97
- NVRAM settings, 123
- NVSRAM
 - downloading, 45
- nvutil
 - see also NVRAM settings

O

- online
 - can't bring controller, 108

P

- parameters
 - changing configuration, 59
 - logical unit, 59
 - polling interval, 81
- parity check/repair
 - default auto setting, 59
- patches
 - required for 32 LUN support, 36
- PCI host adapter, 117
- pkgadd
 - installing update software, 25
- pkginfo, 41
- polling interval, 81
 - see also background monitor
- Power supplies
 - replacing, 103
- preparing to install, 9
- problems, finding help, 90
- PTI host adapter, 117

- R**
- Raid array monitor
 - stopping and restarting, 101
- RAID level
 - changing, 60
- RAID Module
 - configurations supported, 116
 - removing configuration, 101
- RAID module
 - adding new, 87
 - boot device, 10
 - checking cables, 11
 - checking status, 48
 - configurations supported, 116
 - configuring, 63
 - default configuration, 52
 - editing name and comments, 4, 42, 43
 - identifying configuration, 4, 52
 - independent controllers and, 42
 - locating, 54
 - logical unit limits, 79
 - naming conventions, 42, 43, 78
 - powering down, 7
 - saving profile, 55
 - viewing profile, 55
- raidutil utility, 4, 7
- RDAC
 - creating logical units and, 79
 - defined, 83
 - disabling, 85
 - driver, 83
 - driver loaded, 28
 - dump/swap device and, 6
 - illustrated, 84
 - not supported
 - effects, 85
 - starting daemons, 29
- RDAC_HotAddDisabled parameter, 87
- rdacutil command
 - restriction, 100
 - see also Command line commands
- reboot
 - dead luns and, 7
 - when required, 79, 80
- Reconstruction
 - drive fault light, 104
- reconstruction
 - changing rate of, 62
- Recovery Guru
 - troubleshooting, 103
- Recovery guru, 104, 105
 - removing modules, 101
 - takes a long time, 103
- removing, 32, 88
- replacing controllers, 107
 - can't bring online, 108
 - replacement controller restriction, 6
 - restriction on firmware version, 6
- Reset configuration, 97
 - doesn't work, 97
- reset configuration
 - LUN 0 and, 80
- Restrictions
 - batch file failed, 100
 - can't see controllers, 101
 - cannot secure access to LUNs, 102
 - LUNs not visible, 101
- restrictions
 - firmware versions for replacement controllers, 6
 - LUN limits, 79
 - software and operating system, 6
- rmparams
 - file contents, 124
- rmparams file
 - 32 LUN support, 13, 36, 66
 - backing up, 36
 - backup copy, 66
 - man page for, 66
 - modifying, 66
 - for 32 LUN support, 36
 - for SNMP, 73
 - Rdac_HotAddDisabled parameter, 87
 - when to change, 66
- rmscript
 - backup copy of, 70
 - scriptable notification, 14, 70

S

screen illustrations

- configuration application, 53
- module profile, 56

scriptable notification

- see `rmscript`

scripts

- `genscsiconf`, 37
- `hot_add`, 85, 87
- `rmscript`, 70

SCSI, 11, 117

- host adapters, 117, 118

SCSI ID

- see host-side ID

segment size

- changing, 61

settings, NVRAM, 123

shutdown, 37

simple network management protocol

- see `SNMP`

single-initiator configuration

- defined, 116

slot A controller, 113

SNMP

- disabling, 13, 66, 74
- enabling, 13, 66, 73
- MIB file and, 72
- set up NMS, 72
- trap messages
 - contents, 75

SNMP_Action_Number parameter, 68

SNMP_Community_Name parameter, 68

SNMP_Target_IP_Address parameter, 68

Software

- can't view LUNs, 101
- exclusive access required, 101, 102
- options grayed out, 101

software

- administrator privileges required, 40
- background monitor, 81
- features, 3
- incompatible versions detected, 109
- installing, 20
 - standard configuration, 15
- requirements, 9
- restrictions, 6

starting, 40

support changes, 12

troubleshooting, 96

uninstalling, 32, 88

version level, 2

version required, 10

Solaris

adding logical units to, 64, 79

device name, 78

installing with, 20

LUN limits, 79

requirements, 10

restrictions with software, 6

versions supported, ?? to 3, 3 to ??

Solaris 7

Fibre Channel, 116

solutions, locating, 90

starting

background monitor, 82

storage management software, 40

start-of-day

delays during, 36

Status

non-optimal, 103

unexpected, 106

Sun host adapter, 117

switches (fibre channel)

Brocade, 118

switches (fibre channel), 118

Symbios host adapter, 117

System_DefaultModuleSelect parameter, 68

System_MaxLunsPerController parameter, 37, 69

T

trap messages

contents, 75

see also SNMP

Troubleshooting

failed drives, 104

List/Locate won't work, 97

resetting battery age, 102

second controller fails, 100

uninstalling, 100

troubleshooting

application search, 94

components search, 91

Configuration application, 97

general for all applications, 100

locating solutions, 90

Recovery Guru/Health Check, 103

replacing controllers, 107

can't bring online, 108

firmware mismatch, 109

incompatible software, 109

software search, 96

U

Unassigned drives

failed, 97

Uninstalling

not all files removed message, 100

Unresponsive drives, 97, 103

upgrading firmware, 44

requirements, 121

troubleshooting, 99

upgrading firmware 2.5.3 or earlier, 113

User Guide

when to use, 2, 64

utilities

see also command line utilities

V

verifying installation, 30

Veritas, 82

cable disconnects and, 7

removing LUNs from control of, 82

Vixel hubs, 118