



**Hitachi Freedom Storage™  
Lightning 9900™ V Series**

**Hitachi Multiplatform Backup/Restore (HMBR)  
User's Guide**



**Notice:** No part of this publication may be reproduced or transmitted in any form or by any means, electronic or mechanical, including photocopying and recording, or stored in a database or retrieval system for any purpose without the express written permission of Hitachi Data Systems Corporation (Hitachi Data Systems).

Hitachi Data Systems reserves the right to make changes to this document at any time without notice and assumes no responsibility for its use. Hitachi Data Systems products and services can only be ordered under the terms and conditions of Hitachi Data Systems' applicable agreements. All of the features described in this document may not be currently available. Refer to the most recent product announcement or contact your local Hitachi Data Systems sales office for information on feature and product availability.

This document contains the most current information available at the time of publication. When new and/or revised information becomes available, this entire document will be updated and distributed to all registered users.

## Trademarks

Hitachi Data Systems is a registered trademark and service mark of Hitachi Data Systems, and the Hitachi Data Systems design mark is a trademark and service mark of Hitachi Data Systems.

Hitachi Freedom Storage and Lightning 9900 are trademarks of Hitachi Data Systems Corporation.

Compaq, Tru64 and OpenVMS are trademarks or registered trademarks of Compaq Computer Corporation.

HP-UX is a registered trademark of Hewlett-Packard Company.

AIX, IBM, OS/390, and S/390 are registered trademarks of International Business Machines Corporation (IBM).

Linux is a registered trademark of Linus Trovalds.

Microsoft, Windows, and Windows NT are registered trademarks or trademarks of Microsoft Corporation.

Novell and NetWare are registered trademarks of Novell, Inc.

Sun and Solaris are trademarks or registered trademarks of Sun Microsystems, Inc.

UNIX is a registered trademark of X/Open Company Limited in the United States and other countries and is licensed exclusively through X/Open Company Limited.

All other brand or product names are or may be trademarks or service marks of and are used to identify products or services of their respective owners.

## Notice of Export Controls

Export of technical data contained in this document may require an export license from the United States government and/or the government of Japan. Please contact the Hitachi Data Systems Legal Department for any export compliance questions.

## Document Revision Level

Revision	Date	Description
MK-92RD136-0	January 2002	Initial Release
MK-92RD136-1	April 2002	Revision 1, supersedes and replaces MK-92RD136-0.

## Source Documents for this Revision

- R136\_1b.doc (RSD source doc).
- RSD email dated 4/3/2002.

## Changes in this Revision

- Updated microcode level to 21-01-xx.
- Updated platform support information in Table 2.1.

# Preface

The *Hitachi Lightning 9900™ V Series Hitachi Multiplatform Backup/Restore (HMBR) User's Guide* describes the HMBR feature and provides instructions for performing HMBR operations. HMBR allows the user to perform standard mainframe\* backup/restore operations on the open-system\* data stored on the 9900V subsystem.

\*In this document, the term "mainframe" refers to S/390®-based systems, and the term "open-system" refers to UNIX®-based platforms (e.g., HP-UX®, IBM® AIX®, and Sun® Solaris™ systems) and/or PC server platforms (e.g., Windows NT® and Windows® 2000 systems).

This user's guide assumes that:

- the user has a background in data processing and understands direct-access storage device (DASD) subsystems and their basic functions,
- the user is familiar with the mainframe and open-system operating systems and the procedures for installing and initializing DASD volumes (disk devices) and managing their use.

**Note:** The term "9900V" refers to the entire 9900V subsystem family, unless otherwise noted. For further information on the 9900V subsystem, please refer to the *Hitachi Lightning 9900™ V Series User and Reference Guide* (MK-92RD100).

**Note:** The use of HMBR and all other Hitachi Data Systems products is governed by the terms of your license agreement(s) with Hitachi Data Systems.

## Microcode Level

This document revision applies to 9900V microcode versions 21-01-xx.

### COMMENTS

Please send us your comments on this document: [doc.comments@hds.com](mailto:doc.comments@hds.com).

Make sure to include the document title, number, and revision.  
Please refer to specific page(s) and paragraph(s) whenever possible.  
(All comments become the property of Hitachi Data Systems Corporation.)

**Thank you!**



# Contents

<b>Chapter 1</b>	<b>Overview of HMBR</b> .....	<b>1</b>
	1.1 Hitachi Multiplatform Backup/Restore .....	1
<b>Chapter 2</b>	<b>Overview of HMBR Operations</b> .....	<b>3</b>
	2.1 HMBR Requirements .....	4
	2.2 Data Format .....	5
	2.3 Internal Track Format.....	6
<b>Chapter 3</b>	<b>Performing HMBR Operations</b> .....	<b>7</b>
	3.1 Preparing for Backup/Restore Operations .....	7
	3.1.1 Volume (LU) Initialization .....	7
	3.1.2 Dataset Allocation .....	8
	3.1.3 Drive Letters on Windows NT® and Windows® 2000 Systems.....	9
	3.2 Performing Backup/Restore Operations.....	9
	3.2.1 Backup Operations.....	10
	3.2.2 Restore Operations .....	11
	<b>Acronyms and Abbreviations</b> .....	<b>13</b>
	<b>Index</b> .....	<b>15</b>

## List of Figures

Figure 2.1	Typical HMBR System Configuration . . . . .	3
Figure 2.2	Data Format of HMBR Device . . . . .	5
Figure 2.3	Internal Track Format of HMBR Device. . . . .	6
Figure 3.1	Example of DSF Initialization . . . . .	7
Figure 3.2	Example of VTOC Generation for an OPEN-3 LU. . . . .	8
Figure 3.3	Example of VTOC Generation for an OPEN-9 LU. . . . .	8
Figure 3.4	Example of Disk-to-Disk Backup Using DFDSS . . . . .	10
Figure 3.5	Example of Disk-to-Tape Backup Using DFDSS . . . . .	10
Figure 3.6	Example of Disk-to-Disk Restore Using DFDSS . . . . .	11

## List of Tables

Table 2.1	HMBR Requirements . . . . .	4
-----------	-----------------------------	---



# Chapter 1 Overview of HMBR

## 1.1 Hitachi Multiplatform Backup/Restore

The Hitachi Multiplatform Backup/Restore (HMBR) feature enables you to perform standard mainframe\* backup and restore operations on the open-system\* data on the 9900V subsystem. HMBR allows the mainframe host to “see” the OPEN-x logical units (LUs) on the 9900V subsystem as 3390 volumes, making these devices available for use by mainframe-based utilities such as DFDSS, DFHSM, DFSMSdss, DFSMSHsm, FDR, and VSE FASTCOPY.

\*In this document, the term “mainframe” refers to S/390®-based systems, and the term “open-system” refers to UNIX®-based platforms (e.g., HP-UX®, IBM® AIX®, and Sun® Solaris™ systems) and/or PC server platforms (e.g., Windows NT® and Windows® 2000 systems).

**Note:** HMBR enables full-volume backup/restore operations only and does not support partial-volume or file-level backup or restore operations. For information on file-level backup-restore for data on the 9900V subsystem, please contact your Hitachi Data Systems account team.

The 9900V HMBR capability provides the following benefits for the user:

- HMBR enables backup/restore of open-system data at host data transfer speeds via the Extended Serial Adapter™ (ExSA) channels (compatible with ESCON® protocol).
- By allowing the mainframe host to perform backup/restore operations on open-system data, HMBR not only reduces the amount of time required to back up the data but also frees up valuable server resources for use by client-server applications.
- HMBR allows the user to apply similar backup procedures and standards to both mainframe and open-system data, providing a centralized data management and disaster recovery environment for both mainframe and open-system data.
- HMBR makes mainframe-based backup media (e.g., tape, disk, automated tape library) available for the open-system data.
- Once the open-system data is backed up on mainframe-based media, the user can apply other data management functions to these volumes, including backup generation management, primary/secondary duplication management, and automatic backup control.

**Note:** The use of the HMBR feature and all other features and products is governed by the terms of your license agreement(s) with Hitachi Data Systems.



## Chapter 2 Overview of HMBR Operations

The HMBR feature is provided by advanced microcode installed on the 9900V subsystem. HMBR allows you to initialize the OPEN-x LUs on the 9900V subsystem as 3390 mainframe LVIs to make them available for mainframe-based backup/restore operations. HMBR emulates the mainframe CKD format to allow the S/390® host to read the FBA-format data on the OPEN-x LUs. HMBR also provides protection for the open-system data by rejecting all mainframe write commands, except those required to initialize the OPEN-x LU as a mainframe device and perform backup/restore operations.

Figure 2.1 shows a typical HMBR system configuration.

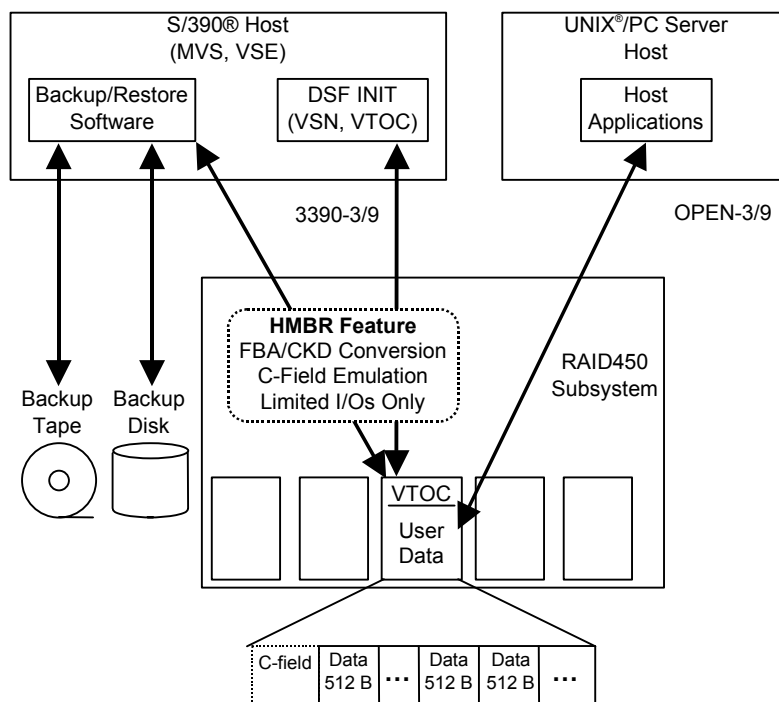

Figure 2.1 Typical HMBR System Configuration

## 2.1 HMBR Requirements

**Table 2.1 HMBR Requirements**

Item	Requirements
Mainframe operating system (OS/390®)	MVS/ESA VSE/ESA
Open-System Platforms	<p>Sun® Solaris™ 2.6, 7, 8</p> <p>HP-UX® 10.20, 11.0, 11.i, 11.20</p> <p>IBM® AIX® 4.3.3, 4.5L</p> <p>Windows NT® 4.0</p> <p>Windows® 2000</p> <p><b>Note:</b> The following platforms will be supported in the initial release of the 9900V series: Linux® (6.0), Netware® (5.1), OpenVMS™ (7.2, 7.3), Tru64™ (5.0A, 5.1, 5.1A) <b>Note:</b> Platforms not listed here are not supported. For the latest information on 9900V platform and version support, please contact your Hitachi Data Systems account team.</p>
Mainframe backup/restore utilities	DFDSS, DFHSM, DFSMSdss, DFSMSshsm VSE FASTCOPY FDR
9900V subsystem	Hitachi Multiplatform Resource Sharing (HMRS) is a prerequisite for HMBR. HMBR feature must be installed and enabled on the 9900V.
Backup/restore method	Full-volume backup/restore only. Partial-volume and file-level backup/restore are not supported.
Logical device types for open-system platforms	OPEN-3 OPEN-9 <b>Note:</b> This device support information was current at the time of publication of this document. For the latest information on 9900V device support, contact your Hitachi Data Systems account team.
Logical device types for mainframe systems	3390-3 3390-9 <b>Note:</b> This device support information was current at the time of publication of this document. For the latest information on 9900V device support, contact your Hitachi Data Systems account team.
Volume serial number (VSN)	Use DSF INIT. Cylinder 0, head 0.
Volume table of contents (VTOC)	Use DSF INIT. Standard format (SMS index format not supported). Cylinder 0, head 1 to 14.
Dataset allocation	Use IEFBR14. Cylinder 1, head 0 to user cylinder max. One dataset per OPEN-3 LU. Three datasets per OPEN-9 LU.

**Table 2.1 HMBR Requirements (continued)**

Item	Requirements
Mainframe access	<p>No access during open-system server use. LUs should be OFFLINE to all mainframe hosts except during backup/restore operations.</p> <p>All control commands are accepted.</p> <p>All read commands are accepted.</p> <p>The following write commands are accepted:  VSN and VTOC creation by DSF INIT (cylinder 0 only).  FORMAT WRITE with KL=0, DL=16 kB by specified backup/restore utilities.</p> <p>All other write commands are rejected: track overrun or invalid track format error.</p> <p>TrueCopy – S/390®, HXRC, and Concurrent Copy cannot be used on HMBR volumes.</p>
Open-system access	<p>No access during mainframe backup/restore operations. LUs should be unmounted from all open-system hosts during mainframe backup/restore.</p>

## 2.2 Data Format

Figure 2.2 shows the data format of an HMBR device. The area accessed only by the mainframe host, which includes the VSN and VTOC on cylinder 0, is in CKD format. Cylinder 0 must be used only for the VSN and VTOC to provide a fixed location for the open-system addressing area. The area accessed by the open-system host, which includes the user data on cylinder 1 through user cylinder max, remains in FBA format. HMBR emulates the CKD format to allow the mainframe host to read the FBA-format data.

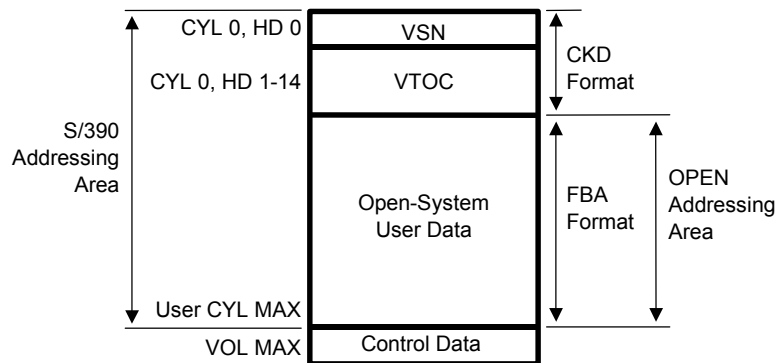

**Figure 2.2 Data Format of HMBR Device**

## 2.3 Internal Track Format

Figure 2.3 shows the internal track format of an HMBR device. The 9900V subsystem stores only the FBA data in cache, with no count-field (C-field). When the mainframe host issues a read command to an HMBR device, the 9900V subsystem generates the C-field and emulates the mainframe CKD format to transfer the data to the host. When the mainframe host issues a write command to an HMBR device, the 9900V subsystem discards the C-field and stores only the data field. All mainframe write commands issued to an HMBR device must consist of a record with key length (KL) of 0 and data length (DL) of 16 kB. The 9900V will reject all other mainframe write commands as having an invalid track format.

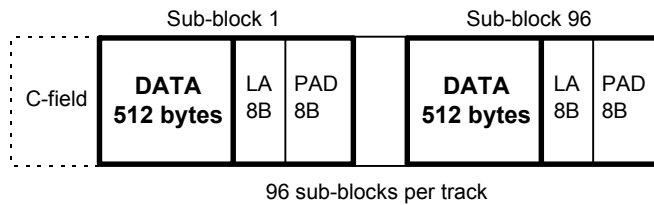

Figure 2.3 Internal Track Format of HMBR Device

# Chapter 3 Performing HMBR Operations

## 3.1 Preparing for Backup/Restore Operations

Your Hitachi Data Systems representative must install and enable the HMBR feature on the 9900V subsystem before the open-system LUs can be accessed by the mainframe. Mainframe access to the open-system LUs will be rejected without the HMBR feature installed and enabled. Once HMBR has been installed and enabled, you can start preparing the open-system LUs on the 9900V subsystem for HMBR operations immediately.

**Note:** If the HMBR feature is de-installed or disabled, the mainframe host will not be able to perform backup/restore operations on the open-system LUs, even if they have been formatted as 3390 volumes, because of the FBA format of the open-system data.

### 3.1.1 Volume (LU) Initialization

The first step in preparing the open-system LUs for mainframe backup/restore operations is to initialize the OPEN-x LUs as 3390 volumes. Use DSF INIT (not SMS) without the **Verify** option to generate the VSN and VTOC for the OPEN-x LU. HMBR requires the standard VTOC format generated by DSF and is not compatible with the index VTOC format generated by SMS. Cylinder 0, head 0 must be used for the VSN, and cylinder 0, head 1 through 14 must be used for the VTOC. Figure 3.1 shows an example of DSF initialization for an OPEN-x LU.

```
//S44INT00 JOB REGION=4096K,MSGCLASS=X,CLASS=U
//INITMIN EXEC PGM=ICKDSF
//SYSPRINT DD SYSOUT=X
//SYSIN DD *
INIT UNIT(7CC0) VFY(*NONE*) VOLID(AAAAAA) VTOC(0000,1,14) NOINDEX
/*
```

Figure 3.1 Example of DSF Initialization

### 3.1.2 Dataset Allocation

The second and final step in preparing the OPEN-x LUs is to allocate the dataset(s). Use IEFBR14 to perform dataset allocation on the new VTOC. Each OPEN-3 LU must contain one dataset, and each OPEN-9 LU must contain three datasets so that the number of tracks does not exceed the maximum allowed per dataset. The specified extent of the dataset(s) must be cylinder 1, head 0 to user cylinder max, and the DAM file must be specified. Figure 3.2 shows an example of dataset allocation for an OPEN-3 LU.

Figure 3.3 shows an example of dataset allocation for an OPEN-9 LU.

**Note:** The amount of data and number of files on the OPEN-x LU is not related to the dataset allocation. The mainframe backup/restore utilities operate on the entire volume, whether it is full or not.

```
//S44IEFBR JOB (QATEST),RAID200,CLASS=Z,MSGCLASS=X,TIME=1440
//DATALLOC EXEC PGM=IEFBR14,COND=(0,LT)
//SYSUT00 DD SPACE=(CYL,3338),UNIT=DASD,VOL=SER=AAAAAA,
//         DSN=HMBR.DUMMY.DATA,DCB=DSORG=DA,
//         DISP=(NEW,KEEP,KEEP)
/*
```

**Figure 3.2** Example of VTOC Generation for an OPEN-3 LU

```
//S44IEFBR JOB (QATEST),RAID200,CLASS=Z,MSGCLASS=X,TIME=1440
//DATALLOC EXEC PGM=IEFBR14,COND=(0,LT)
//SYSUT00 DD SPACE=(CYL,3338),UNIT=DASD,VOL=SER=AAAAAA,
//         DSN=HMBR.DUMMY.DATA00,DCB=DSORG=DA,
//         DISP=(NEW,KEEP,KEEP)
//S44IEFBR JOB (QATEST),RAID200,CLASS=Z,MSGCLASS=X,TIME=1440
//DATALLOC EXEC PGM=IEFBR14,COND=(0,LT)
//SYSUT01 DD SPACE=(CYL,3339),UNIT=DASD,VOL=SER=AAAAAA,
//         DSN=HMBR.DUMMY.DATA01,DCB=DSORG=DA,
//         DISP=(NEW,KEEP,KEEP)
//S44IEFBR JOB (QATEST),RAID200,CLASS=Z,MSGCLASS=X,TIME=1440
//DATALLOC EXEC PGM=IEFBR14,COND=(0,LT)
//SYSUT02 DD SPACE=(CYL,3339),UNIT=DASD,VOL=SER=AAAAAA,
//         DSN=HMBR.DUMMY.DATA02,DCB=DSORG=DA,
//         DISP=(NEW,KEEP,KEEP)
/*
```

**Note:** DSORG=DA (RECFM is not required).

**Figure 3.3** Example of VTOC Generation for an OPEN-9 LU



### 3.1.3 Drive Letters on Windows NT® and Windows® 2000 Systems

The following operations are required when using HMBR with Windows NT® systems:

- **Before Backup:** Delete the drive letter of the LU to be backed up using the Disk Administrator, perform the backup operations, and then reassign the drive letter for the same LU using the Disk Administrator.
- **Before Restore:** Delete the drive letter of the LU to be restored using the Disk Administrator, perform the restore operations, and then reassign the drive letter for the same LU using the Disk Administrator.

## 3.2 Performing Backup/Restore Operations

You can begin backup/restore operations on the HMBR devices as soon as the VSN and VTOC have been generated and the datasets have been allocated. The user should follow these general guidelines for performing and managing HMBR operations:

- HMBR supports the full-volume dump/restore operations performed by DFDSS, DFHSM, DFSMSdss, DFSMSHsm, FDR, and VSE FASTCOPY. HMBR does not support partial-volume or file-level dump or restore. When an OPEN-x LU is restored from its backup copy, the entire volume is replaced. Due to this limitation, it is recommended that you back up the OPEN-x LUs more often than your mainframe volumes to minimize the loss of new data in case you need to restore an OPEN-x LU from its backup copy.
- When backing up and restoring database (DB) files, the user must be careful to include all of the volumes containing DB files, both data files and DB management files, in the backup and restore operations.
- Hitachi Data Systems recommends that the HMBR devices remain OFFLINE to all mainframe hosts except during backup/restore operations to prevent simultaneous access by the mainframe and open-system hosts. If an HMBR device is accessed by the mainframe at the same time as it is being used by an open-system host, the open-system access will result in an error. The mainframe host is not affected and can continue to access the volume.
- Hitachi Data Systems recommends that the HMBR devices be UNMOUNTED from all open-system hosts during mainframe backup/restore operations. Do not access the HMBR device from the open-system host during mainframe backup/restore operations. If simultaneous access does occur, the mainframe backup/restore operation will crash.
- For Windows NT® systems, make sure that you have reassigned/deleted the drive letters as described in section 3.1.3 before beginning backup/restore operations.

### 3.2.1 Backup Operations

Before starting backup operations on any volume, make sure to reserve the volume to prevent access by another mainframe host during backup operations. Use DFDSS, DFHSM, DFSMSdss, DFSMSHsm, FDR, or VSE FASTCOPY to perform backup operations on the OPEN-x LUs. Figure 3.4 shows an example of disk-to-disk backup using DFDSS. Figure 3.5 shows an example of disk-to-tape backup using DFDSS. For additional information on using DFDSS, DFHSM, DFSMSdss, DFSMSHsm, FDR, or VSE FASTCOPY to perform backup operations, please refer to the user documentation for these software products.

For Windows NT® systems, make sure that you have reassigned the drive letters as described in section 3.1.3 before beginning backup operations.

```
//S44DFDSS JOB 82080,'USER',MSGCLASS=X,MSGLEVEL=(1,1),
//          NOTIFY=USERNAME,CLASS=A
//FULLDUMP EXEC PGM=ADRDSSU,REGION=5000K
//SYSOUT   DD SYSOUT=*
//SYSPRINT DD SYSOUT=*
//SCSIIN   DD UNIT=3390,VOL=SER=SCSI51,DISP=(OLD,KEEP),
//          DSN=HMBR.DUMMY.DATA
//DASDOUT   DD UNIT=3390,DSN=SCSI51.BACKUP,
//          SPACE=(CYL,(1500,500)),
//          DISP=(OLD,KEEP,DELETE),VOL=SER=AAAAAA
//SYSUDUMP DD SYSOUT=*
//SYSIN    DD *
           DUMP FULL ALLDATA(*) ALLEXCP CANCELEERROR COMPRESS OPTIMIZE(4) -
           INDDNAME(SCSIIN) OUTDDNAME(DASDOUT)
/*
```

**Figure 3.4** Example of Disk-to-Disk Backup Using DFDSS

```
//USER JOB '85042',MSGCLASS=X,REGION=2048K,
//          NOTIFY=USERNAME
//S1      EXEC PGM=ADRDSSU
//SYSPRINT DD SYSOUT=*
//DASD1   DD UNIT=3390,VOL=SER=SCSI51,DISP=SHR
//TAPE    DD UNIT=3490,VOL=SER=(AB1130,AB0400),LABEL=(1,NL),
//          DSN=BACKUP.VSCSI51,DISP=(NEW,KEEP)
//          DISP=(OLD,KEEP,DELETE),VOL=SER=AAAAAA
//SYSIN   DD *
           DUMP FULL ALLDATA(*) ALLEXCP CANCELEERROR COMPRESS OPTIMIZE(4) -
           INDDNAME(DASD1) OUTDDNAME(TAPE)
/*
```

**Figure 3.5** Example of Disk-to-Tape Backup Using DFDSS

## 3.2.2 Restore Operations

Before starting restore operations on any volume, make sure to reserve the volume to prevent access during restore operations. Use DFDSS, DFHSM, DFSMSdss, DFSMSHsm, FDR, or VSE FASTCOPY to perform restore operations on OPEN-x LUs. Figure 3.6 shows an example of disk-to-disk restore using DFDSS. For additional information on using DFDSS, DFHSM, DFSMSdss, DFSMSHsm, FDR, or VSE FASTCOPY to perform restore operations, please refer to the user documentation for these software products.

For Windows NT® systems, make sure that you have deleted the drive letters as described in section 3.1.3 before beginning restore operations.

```
//S44DFDSS JOB 69540, 'USER',MSGCLASS=X,MSGLEVEL=(1,1),
//          NOTIFY=USERNAME,CLASS=A
//RESTORE EXEC PGM=ADRDSSU,REGION=6M
//SYSPRINT DD SYSOUT=*
//DASDIN DD UNIT=3390,VOL=SER=AAAAAA,DISP=(OLD,DELETE,DELETE),
//        DSN=SCSI51.BACKUP
//SCSIOUT DD UNIT=3390,VOL=SER=SCSI51,DISP=OLD
//SYSIN DD *
RESTORE FULL CANCELERROR INDDNAME(DASDIN) OUTDDNAME(SCSIOUT)
/*
```

**Figure 3.6** Example of Disk-to-Disk Restore Using DFDSS

The restore operation must access the same volume that was used in the backup operation. If the restore destination volume is different than the backup source volume, the open-system host will not recognize the volume after the restore operation. For example, HP-UX® will return the following error messages:

**Example 1:**

```
# mount /dev/vg01/lvol1 /01
mount: /dev/vg01/lvol1:No such device or address
```

**Example 2:**

```
# fsck -m /dev/rdisk/c2t2d0
fsck:/etc/default/fs is used for determining the file system type
fsck:sanity check, /dev/rdisk/c2t2d0 is badly_damaged
```

If this error occurs, you must install the volume again from the open-system host (e.g., partition, label, create file system, etc.). For further information on installing LUs, please refer to the user documentation for the open-system OS.



# Acronyms and Abbreviations

C-field	count-field
CKD	count-key data
DAM	direct-access method
DASD	direct-access storage device
DB	database
DFDSS	Data Facility Data Set Services
DFHSM	Data Facility Hierarchical Storage Manager
DFSMS	Data Facility Storage Management Subsystem
DL	data length
DSF	Device Support Facilities
ESA	Enterprise Systems Architecture
ESCON®	Enterprise System Connection (IBM trademark for optical channels)
ExSA	Extended Serial Adapter
FBA	fixed-block architecture
FDR	Fast Dump Restore (trademark of Innovation Data Processing)
GB	gigabytes
HMBR	Hitachi Multiplatform Backup/Restore
HMRS	Hitachi Multiplatform Resource Sharing
HXRC	Hitachi Extended Remote Copy
I/O	input/output
kB	kilobytes
KL	key length
LU	logical unit
LVI	logical volume image
MB	megabytes
MVS	Multiple Virtual Storage
OS	operating system
S/390	System/390
SCSI	small computer system interface
sec	second
SMS	System Managed Storage
VSE	Virtual Storage Extended
VSN	volume serial number (also called volser)
VTOC	volume table of contents



# Index

## A

allocating the dataset, 8

## B

backup media, 1  
backup operations, 10  
backup/restore utilities, 4

## C

CKD format, 5  
count-field (C-field), 5  
cylinder 0, 4, 5, 7

## D

data format (CKD, FBA), 5  
dataset allocation, 4, 8  
DB files, 9  
device types, 4  
disk-to-disk backup example, 10  
disk-to-disk restore example, 11  
disk-to-tape backup example, 10  
drive letters on Windows NT<sup>®</sup> systems, 9

## E

ESCON<sup>®</sup> protocol, 1  
ExSA<sup>™</sup> channels, 1

## F

FBA format, 5  
file-level operations NOT supported, 9

## H

HMBR  
backup operations, 10  
data format (CKD, FBA), 5  
file-level operations NOT supported, 9  
offline/unmounted devices, 9  
operations, 3  
overview, 1  
preparing for operations, 7-9  
requirements, 4  
restore operations, 11  
system configuration, 3  
track format, 5  
volume-level operations, 9  
Windows NT<sup>®</sup> drive letters, 9

## I

initializing the volumes (LUs), 7  
LU/LVI types, 4

## M

mainframe  
backup/restore utilities, 4  
operating systems, 4  
read/write commands to HMBR device, 5

## O

offline devices, 9  
open-system platforms, 4  
operating systems, 4  
operations, 3  
overview of HMBR, 1

## P

PC server platforms, 4  
platform support, 4  
preparing for HMBR operations, 7-9

## R

read command to HMBR device, 5  
requirements, 4  
restore operations, 11

## T

track format, 5

## U

UNIX<sup>®</sup>-based platforms, 4  
unmounted devices, 9

## V

volume serial number (VSN), 4  
volume-level operations, 9  
VSN, 4, 7  
VTOC, 4, 7-9

## W

Windows NT<sup>®</sup> systems  
drive letters, 9  
write command to HMBR device, 4, 5

