



Netra™ X1 Server User's Guide

Sun Microsystems, Inc.
901 San Antonio Road
Palo Alto, CA 94303
U.S.A. 650-960-1300

Part No. 806-5980-10
December 2000

[Send comments about this document to: docfeedback@sun.com](mailto:docfeedback@sun.com)

Copyright 2000 Sun Microsystems, Inc., 901 San Antonio Road, Palo Alto, CA 94303-4900 U.S.A. All rights reserved.

This product or document is distributed under licenses restricting its use, copying, distribution, and decompilation. No part of this product or document may be reproduced in any form by any means without prior written authorization of Sun and its licensors, if any. Third-party software, including font technology, is copyrighted and licensed from Sun suppliers.

Parts of the product may be derived from Berkeley BSD systems, licensed from the University of California. UNIX is a registered trademark in the U.S. and other countries, exclusively licensed through X/Open Company, Ltd.

Sun, Sun Microsystems, the Sun logo, AnswerBook2, docs.sun.com, UltraSPARC™-Ile, OpenBoot™ PROM, SunSolve, Solaris, and Netra are trademarks, registered trademarks, or service marks of Sun Microsystems, Inc. in the U.S. and other countries. All SPARC trademarks are used under license and are trademarks or registered trademarks of SPARC International, Inc. in the U.S. and other countries. Products bearing SPARC trademarks are based upon an architecture developed by Sun Microsystems, Inc.

The OPEN LOOK and Sun™ Graphical User Interface was developed by Sun Microsystems, Inc. for its users and licensees. Sun acknowledges the pioneering efforts of Xerox in researching and developing the concept of visual or graphical user interfaces for the computer industry. Sun holds a non-exclusive license from Xerox to the Xerox Graphical User Interface, which license also covers Sun's licensees who implement OPEN LOOK GUIs and otherwise comply with Sun's written license agreements.

Federal Acquisitions: Commercial Software—Government Users Subject to Standard License Terms and Conditions.

DOCUMENTATION IS PROVIDED "AS IS" AND ALL EXPRESS OR IMPLIED CONDITIONS, REPRESENTATIONS AND WARRANTIES, INCLUDING ANY IMPLIED WARRANTY OF MERCHANTABILITY, FITNESS FOR A PARTICULAR PURPOSE OR NON-INFRINGEMENT, ARE DISCLAIMED, EXCEPT TO THE EXTENT THAT SUCH DISCLAIMERS ARE HELD TO BE LEGALLY INVALID.

Copyright 2000 Sun Microsystems, Inc., 901 San Antonio Road, Palo Alto, CA 94303-4900 Etats-Unis. Tous droits réservés.

Ce produit ou document est distribué avec des licences qui en restreignent l'utilisation, la copie, la distribution, et la décompilation. Aucune partie de ce produit ou document ne peut être reproduite sous aucune forme, par quelque moyen que ce soit, sans l'autorisation préalable et écrite de Sun et de ses bailleurs de licence, s'il y en a. Le logiciel détenu par des tiers, et qui comprend la technologie relative aux polices de caractères, est protégé par un copyright et licencié par des fournisseurs de Sun.

Des parties de ce produit pourront être dérivées des systèmes Berkeley BSD licenciés par l'Université de Californie. UNIX est une marque déposée aux Etats-Unis et dans d'autres pays et licenciée exclusivement par X/Open Company, Ltd.

Sun, Sun Microsystems, le logo Sun, AnswerBook2, docs.sun.com, UltraSPARC™-Ile, OpenBoot™ PROM, Solaris et Netra sont des marques de fabrique ou des marques déposées, ou marques de service, de Sun Microsystems, Inc. aux Etats-Unis et dans d'autres pays. Toutes les marques SPARC sont utilisées sous licence et sont des marques de fabrique ou des marques déposées de SPARC International, Inc. aux Etats-Unis et dans d'autres pays. Les produits portant les marques SPARC sont basés sur une architecture développée par Sun Microsystems, Inc.

L'interface d'utilisation graphique OPEN LOOK et Sun™ a été développée par Sun Microsystems, Inc. pour ses utilisateurs et licenciés. Sun reconnaît les efforts de pionniers de Xerox pour la recherche et le développement du concept des interfaces d'utilisation visuelle ou graphique pour l'industrie de l'informatique. Sun détient une licence non exclusive de Xerox sur l'interface d'utilisation graphique Xerox, cette licence couvrant également les licenciés de Sun qui mettent en place l'interface d'utilisation graphique OPEN LOOK et qui en outre se conforment aux licences écrites de Sun.

LA DOCUMENTATION EST FOURNIE "EN L'ETAT" ET TOUTES AUTRES CONDITIONS, DECLARATIONS ET GARANTIES EXPRESSES OU TACITES SONT FORMELLEMENT EXCLUES, DANS LA MESURE AUTORISEE PAR LA LOI APPLICABLE, Y COMPRIS NOTAMMENT TOUTE GARANTIE IMPLICITE RELATIVE A LA QUALITE MARCHANDE, A L'APTITUDE A UNE UTILISATION PARTICULIERE OU A L'ABSENCE DE CONTREFAÇON.



Contents

Part I. Installation and Configuration

- 1. Introducing the Netra X1 Server 1**
 - Overview of the Netra X1 Server 2
 - Physical Specifications 3
 - Contents of the Ship Kit 3
 - Optional Components 4
 - Environmental Specifications 4
 - Acoustic Noise Generated 5
 - Environmental Compliance Information 5
 - Choosing Between a Rack and a Cabinet 5
- 2. Operating Power and Cooling 7**
 - Operating Power Statistics 8
 - Calculating Power Consumption 9
 - Calculating Heat Dissipation 9
- 3. Installing the Netra X1 Server Into a Rack 11**
 - Installing the Server Into a Standard 19-inch Rack 12
 - Using Alternative Bracket Arrangements 13

- 4. Connecting the Cables 15**
 - Connecting the Cables to the Server 16
 - Setting Up Serial Connections 18
 - Using a DB-25 Adapter for the Serial Link 20
 - Using a DB-9 Adapter for the Serial Link 21
 - Serial Connection Settings 22

- 5. Powering On the Netra X1 Server 23**
 - Preparing to Configure the Server 24
 - Powering On the Server for the First Time 25
 - Using the Power (On/Standby) Switch 30

Part II. Remote and Local Management

- 6. Managing the Netra X1 Server From the `lom>` Prompt 35**
 - Introduction to Lights-Out Management 36
 - Powering On or Resetting the Server From the LOMlite2 Shell 36
 - Controlling the Server's Booting Behavior 40
 - Monitoring the Server From the LOMlite2 Shell 41
 - Viewing the LOMlite2 Event Log 43
 - Verifying That a Component Has Been Fixed 45
 - Setting Up LOMlite2 Privileges for Named Users 46
 - Permissions Available for LOMlite2 Users 46
 - Setting the LOMlite2 Device's Configurable Variables 50
 - Separating LOMlite2 From the Console on the Serial A/LOM Port 52
 - Viewing Event Reports That LOMlite2 Sends to `syslogd` 53
 - LOMlite2 Shell Command List 54
 - Checking the Fans 56

- 7. Managing the Netra X1 Server From the Solaris Prompt 57**

Monitoring the System From the Solaris Prompt	58
Checking the Supply Rail Voltages and Internal Circuit Breakers (lom -v)	59
Configuring LOMlite2 to Restart the Server Automatically After a Lockup	64
Enabling the LOMlite2 Watchdog Process From Your Own Script or Command (lom -W on)	65
Other LOM Tasks You Can Perform From the Solaris Prompt	67

Part III. Troubleshooting and Maintenance

8. Troubleshooting 73

Solutions to Problems You Might Encounter	74
---	----

9. Interpreting the LEDs 77

Interpreting the Front- and Back-Panel LEDs	78
---	----

Front-Panel LEDs	78
------------------	----

Back-Panel LEDs	79
-----------------	----

10. Removing and Replacing Components 81

Replacing an Entire Netra X1 Server	82
-------------------------------------	----

Altering a Netra X1 Server	83
----------------------------	----

Identifying Components	87
------------------------	----

Memory Installation and Removal	88
---------------------------------	----

Hard Disk Drive (HDD) Installation and Removal	89
--	----

Part IV. Appendix

Figures

- FIGURE 1-1 The Netra X1 Server 2
- FIGURE 3-1 Mounting the Server in a Standard 19-inch Rack 12
- FIGURE 3-2 Forward Facing Rackmounting Brackets 13
- FIGURE 3-3 Rear Facing Rackmounting Brackets 13
- FIGURE 3-4 Alternative Rackmounting Position 14
- FIGURE 4-1 The Server's Back Panel 16
- FIGURE 4-2 Connecting Cables to the Netra X1 Server 17
- FIGURE 4-3 Patch Panel Connection Between a Cisco L2511 Server and a Netra X1 Server 19
- FIGURE 4-4 Serial Port Pins 1 to 8 20
- FIGURE 5-1 Netra X1 Server Power (On/Standby) Switch 30
- FIGURE 7-1 Sample LOMlite2 Device Event Log (Oldest Event Reported First) 63
- FIGURE 9-1 Front-Panel Power and Fault LEDs 78
- FIGURE 9-2 Back-Panel Power and Fault LEDs 80
- FIGURE 10-1 The System Configuration Card Reader 83
- FIGURE 10-2 Using the Disposable Antistatic Wrist Strap Supplied With the System 84
- FIGURE 10-3 Removing the Top Cover 85
- FIGURE 10-4 Replacing the Top Cover 86
- FIGURE 10-5 Layout of Components 87
- FIGURE 10-6 DIMM Insertion Order 88

FIGURE 10-7 Installing Memory Into a Socket on the System Board 89

FIGURE 10-8 Removing the HDD Placeholder 90

FIGURE 10-9 Installing a Hard Disk Drive 91

FIGURE 10-10 Attaching the Power and Data Cables 91

Tables

TABLE 1-1	Physical Specifications	3
TABLE 1-2	Contents of the Ship Kit	3
TABLE 1-3	Customer Installable Hardware	4
TABLE 1-4	Environmental Specifications	4
TABLE 2-1	Operating Power Statistics	8
TABLE 2-2	Estimated Power Consumption of the Netra X1 Server Components	9
TABLE 4-1	Pin Crossovers for Connecting to a Typical Terminal Server	20
TABLE 4-2	Pin Crossovers in the Sun DB-25 (25-Pin) Adapter	21
TABLE 4-3	Pin Crossovers for a DB-9 (9-Pin) Adapter	21
TABLE 4-4	Settings for Connecting to the Serial A/LOM or Serial B Port	22
TABLE 6-1	Boot Modes	40
TABLE 6-2	LOM Commands	54

Preface

The *Netra X1 Server User's Guide* describes how to install, manage, and maintain the Netra™ X1 server. The manual is intended for system administrators who have experience in setting up networked Solaris™ servers.

How This Book Is Organized

Part I Installation and Configuration

Chapter 1 introduces the Netra X1 server, provides an overview of the system and includes information on physical operating conditions and rackmounting implications.

Chapter 2 provides information about the power and cooling requirements for the Netra X1 server.

Chapter 3 provides instructions on installing the Netra X1 server into a standard 19-inch rack and describes the various bracket-mounting options that are available.

Chapter 4 specifies how to attach the cables and power source to the Netra X1 server and how to set up serial connections to it.

Chapter 5 explains how to perform the initial power-on and configuration of the server.

Part II Netra X1 Remote and Local Management

Chapter 6 explains how to use the LOMlite2 shell.

Chapter 7 describes how to use LOMlite2-specific Solaris commands to monitor and manage the system. This chapter also explains how to configure LOMlite2 to restart the server in the event of a system lockup.

Part III Troubleshooting and Maintenance

Chapter 8 summarizes some possible problems with setting up the server and explains how to overcome them.

Chapter 9 provides information about the fault and power indicators and explains how to identify a faulty system in a rack.

Chapter 10 describes how to swap system configuration cards and how to open the Netra X1 server to add memory or a hard disk drive.

Part IV Appendix

Appendix A describes the parameters you can configure in the LOMlite2 driver configuration file.

Using UNIX Commands

This document may not contain information on basic UNIX[®] commands and procedures such as shutting down the system, booting the system, and configuring devices.

See one or more of the following for this information:

- *Solaris Handbook for Sun Peripherals*
- AnswerBook2[™] online documentation for the Solaris software environment
- Other software documentation that you received with your system

Typographic Conventions

Typeface	Meaning	Examples
AaBbCc123	The names of commands, files, and directories; on-screen computer output	Edit your <code>.login</code> file. Use <code>ls -a</code> to list all files. % You have mail.
AaBbCc123	What you type, when contrasted with on-screen computer output	% su Password:
<i>AaBbCc123</i>	Book titles, new words or terms, words to be emphasized	Read Chapter 6 in the <i>User's Guide</i> . These are called <i>class</i> options. You <i>must</i> be superuser to do this.
	Command-line variable; replace with a real name or value	To delete a file, type <code>rm filename</code> .

Shell Prompts

Shell	Prompt
C shell	<i>machine_name</i> %
C shell superuser	<i>machine_name</i> #
Bourne shell and Korn shell	\$
Bourne shell and Korn shell superuser	#
LOM shell	lom>
OBP	ok>

Sun Welcomes Your Comments

We are interested in improving our documentation and welcome your comments and suggestions. You can email your comments to us at:

`docfeedback@sun.com`

Please include the part number (806-5980-10) of your document in the subject line of your email.

Safety Precautions

For your protection, observe the following safety precautions when setting up your equipment:

- Follow all cautions and instructions marked on the equipment.
- Never push objects of any kind through openings in the equipment. Dangerous voltages may be present. Conductive foreign objects can produce a short circuit that could cause fire, electric shock, or damage to your equipment.

Symbols

The following symbols may appear in this manual:



Caution – There is a risk of personal injury and equipment damage. Follow the instructions.



Caution – Hazardous voltages are present. To reduce the risk of electric shock and danger to personal health, follow the instructions.

Modifications to Equipment

Do not make mechanical or electrical modifications to the equipment. Sun Microsystems is not responsible for the regulatory compliance of a modified product.



Caution – Do not block or cover the openings of your Sun product. Never place a Sun product near a radiator or heat register. Failure to follow these guidelines can cause overheating and affect the reliability of your Sun product.



Caution – If your Netra X1 server is installed in a closed or multi-unit rack assembly, the operating ambient temperature of the rack environment may exceed the room ambient temperature. Ensure that rack environment ambient temperature does not exceed 40 degrees.



Caution – Mounting of the equipment in a rack or cabinet should be such that a hazardous condition is not created due to uneven mechanical loading or weight distribution.



Caution – Ensure that the connection of multiple system units to the circuit does not overload the supply overcurrent protection or supply wiring. Consider the Sun agency label electrical ratings when determining the correct branch circuit rating for your installation.



Caution – All supply connections, wiring, wire protection, and wire routing must be made in accordance with applicable sections and requirements of national electrical code and local electrical authorities.

PART I **Installation and Configuration**

Introducing the Netra X1 Server

This chapter gives an overview of the NetraX1 server. It lists the features of the server and the contents of the ship kit, and describes the server's tolerance of, or suitability for, various environmental conditions. Finally, the chapter offers some guidance to help you decide whether to mount the system in a rack or a cabinet.

The chapter contains the following sections:

- “Overview of the Netra X1 Server” on page 2
- “Contents of the Ship Kit” on page 3
- “Optional Components” on page 4
- “Environmental Specifications” on page 4
- “Choosing Between a Rack and a Cabinet” on page 5

Overview of the Netra X1 Server

The Netra X1 server is a single-processor, thin (1U) server designed primarily for use by telecommunications carriers and internet service providers. It is also suitable for use within corporate customer networks, wherever there is a need to maximize the density of high-performance Solaris servers.

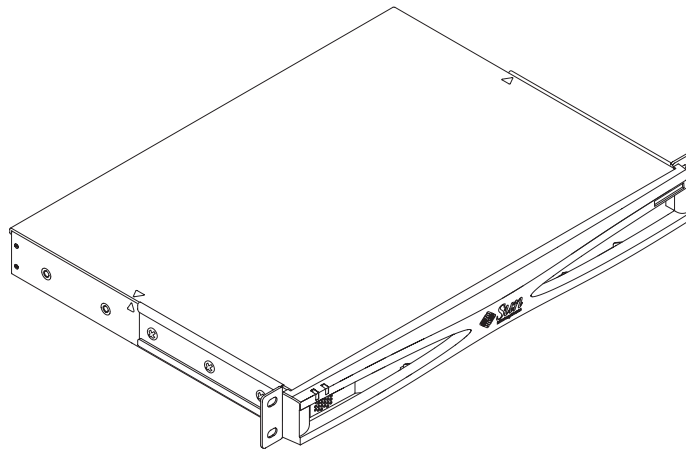

FIGURE 1-1 The Netra X1 Server

The server has the following features:

- Single UltraSPARC™-IIe 400 MHz processor
- Rackmounting enclosure with single power supply
- Four DIMM sockets accepting standard 128- or 256-Mbyte PC133 memory modules (giving a maximum of 1 Gbyte of memory)
- Two 10/100 Mbps RJ-45 Ethernet ports
- Console/Lights Out Management RJ-45 serial port
- Second RJ-45 serial port
- Two USB ports
- Support for up to two low-profile, 3.5-inch IDE disks

Physical Specifications

TABLE 1-1 Physical Specifications

Dimension	U.S.	Metric
Height	1.72 in.	43.6 mm
Width	17.55 in.	445 mm
Depth	13.21 in.	335 mm
Weight	6 kg (with two hard disk drives and four memory modules installed)	

Contents of the Ship Kit

TABLE 1-2 Contents of the Ship Kit

Item	Part Number	Quantity
RJ-45 to RJ-45 patch cable for Ethernet or serial connection	530-2961-xx	2
RJ-45 to DB-25 adapter	530-2889-xx	1
Rackmounting screws, 10-32x1/2	240-1207-xx	4
Antistatic wrist strap	250-1007-xx	1
<i>Netra X1 Server User's Guide</i>	806-5980-xx	1
<i>Netra X1 Server Safety and Compliance Guide</i>	806-6136-xx	1
<i>Netra X1 Server Release Notes</i>	806-6137-xx	1

Optional Components

Sun offers additional hard disk drives and memory modules for the server. To order them, contact your local Sun sales representative. See TABLE 1-3 for a list of components and part numbers. The server itself was designed as a replaceable unit which means that, if a fault occurs, you should contact your local Sun sales representative for a replacement

TABLE 1-3 Customer Installable Hardware

Optional Components	Part Number
128-Mbyte DIMM	X7090A
256-Mbyte DIMM	X7091A
20 Gbyte, 5400 rpm hard disk drive	X7095A

Environmental Specifications

You can operate and store the system safely in the following conditions:

TABLE 1-4 Environmental Specifications

Specifications	Operating	Storage
Ambient temperature	5°C to 40°C 14°F to 104°F	-40°C to 70°C -8°F to 158°F
Temperature variation	30°C/hr maximum 86°F/hr maximum	30°C/hr maximum 86°F/hr maximum
Relative humidity	5% to 85% (noncondensing)	10% to 95% (noncondensing)
Altitude	-300m to +3000m	-300m to +12000m

Acoustic Noise Generated

The system generates less than 60 dBA at a distance of 23.67 inches (600 mm) and a height of 59.17 inches (1500 mm) while operating in an ambient temperature of 77°F (25°C).

Environmental Compliance Information

- Electromagnetic compatibility
 - Immunity: The server conforms to EN55024.
 - Emissions: The server conforms to EN55022 Class A and FCC Class A.
 - Safety
 - The system conforms to UL 1950 (3rd edition), EN60950
-

Choosing Between a Rack and a Cabinet

A Netra X1 server can be installed in either a rack or a cabinet. Factors that might influence your decision include:

- **Security**
If other people have access to the room in which your servers are located, you can increase security by locking the servers in a cabinet.
- **Thermal issues**
Cabinets often require additional fans, because the systems installed in them generate heat in an enclosed space. Two-post racks, however, may require no special cooling systems.
- **Flooring**
Two-post telco relay racks are designed so that cables can be run overhead. Cabinets often require cables to be run under the floor.

Operating Power and Cooling

This chapter describes the power consumption and heat generation characteristics of the Netra X1 server. It contains the following sections:

- “Operating Power Statistics” on page 8
- “Calculating Power Consumption” on page 9
- “Calculating Heat Dissipation” on page 9

Operating Power Statistics

TABLE 2-1 Operating Power Statistics

Maximum operating current	3A @ 115 VAC
Typical operating current	See “Calculating Power Consumption” on page 9
Maximum in-rush current (cold start)	40A peak at 115V 25°C
Maximum in-rush current (warm start, or upon a restart 20 to 200 msec after power has been removed*)	100A peak at 115V 25°C
Operating input voltage range	90 to 264 Vrms
Voltage frequency range	47 to 63 Hz
Power factor	0.9 to 0.99
Maximum volt-ampere rating	150 VA
BTU rating	493.6 BTU**

* The in-rush current decays to the normal operating current in less than 200 msec.

** This BTU assumes a system fully loaded with hardware option modules (see “Calculating Heat Dissipation” on page 9).



Caution – The power supply continues to regulate all outputs for at least 17 ms after AC power is removed.

Note – Logic ground and chassis ground are connected internally.

Note – Power from the standby output is available whenever input power is connected.

Calculating Power Consumption

A Netra X1 server containing two disk drives has an estimated current requirement of approximately 1 amp.

TABLE 2-2 shows the estimated power consumed by the individual components in a fully powered system. However, when you are calculating the power requirements for your system, you must allow for 63 percent PSU efficiency. To perform this calculation, add the figures (from the third column of TABLE 2-2) for each component installed in the system, then divide the result by 0.63.

TABLE 2-2 Estimated Power Consumption of the Netra X1 Server Components

Component	Measurement	Estimated Power Consumption
Base system	400 MHz	20.0W
Memory	per DIMM	4.59W (256 Mbytes, burst mode)
Disk drive	20 Gbyte/5400 rpm	6.5W (idle)

Note – To calculate the total power requirement for several servers installed in a single rack or cabinet, you add the individual power requirement figure (TABLE 2-2) for each server installed.

Calculating Heat Dissipation

To calculate the heat generated by a server so that you can estimate the heat your cooling system must dissipate, convert the figure for the system's power requirement from watts to BTU/hr. A general formula for doing this is to multiply the figure for the power requirement by 3.415.

Installing the Netra X1 Server Into a Rack

This chapter explains how to install the Netra X1 server into a standard 19-inch rack and describes the various mounting options available. This information is given in the following sections:

- “Installing the Server Into a Standard 19-inch Rack” on page 12
- “Using Alternative Bracket Arrangements” on page 13

Installing the Server Into a Standard 19-inch Rack

The Netra X1 server fits a standard 19-inch rack. There are five mounting points for the brackets on each side of the server, allowing a choice of mounting positions. The standard position uses the forward three mounting points on the server (see FIGURE 3-2).

You can adjust the position of the server in the rack by using a different set of mounting points for the brackets (see FIGURE 3-4).

▼ To Mount the Server in a 19-inch Rack

1. **Position the Netra X1 server in the rack and tighten the screws (see FIGURE 3-1).**
2. **Attach the cables (see Chapter 4).**

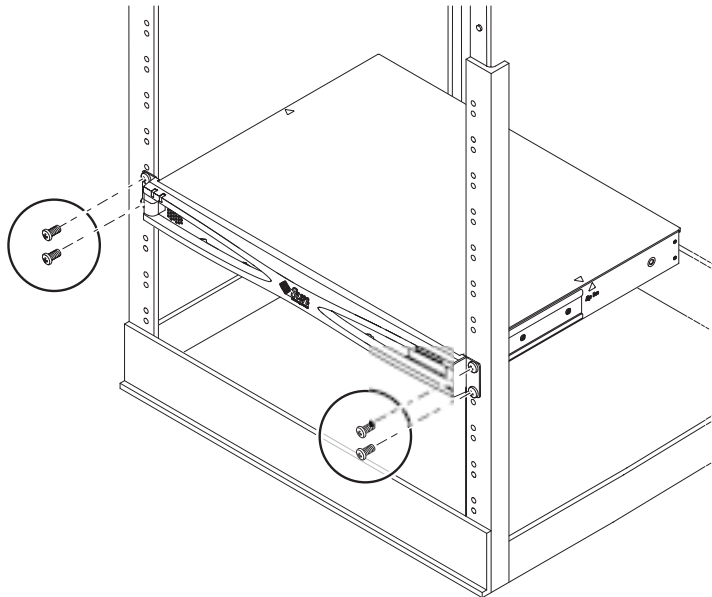

FIGURE 3-1 Mounting the Server in a Standard 19-inch Rack

Using Alternative Bracket Arrangements

The server can be mounted in various positions in a rack by changing the position of the rackmounting brackets on the server. The brackets be attached to any three of the mounting points on the side of the server, facing either to the front (see FIGURE 3-2) or to the rear of the server (see FIGURE 3-3).

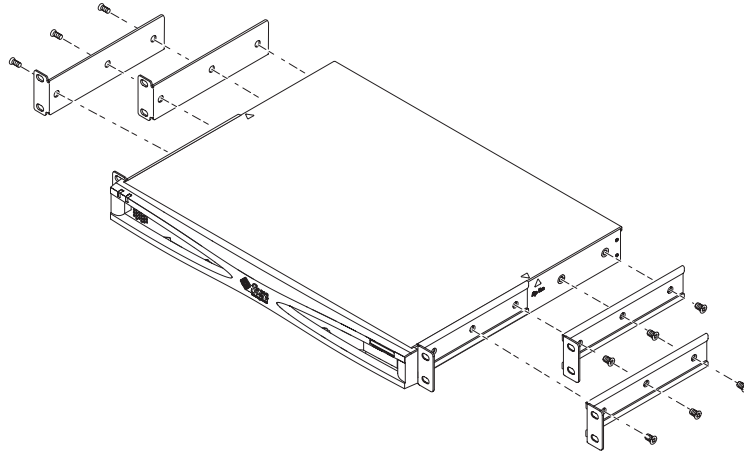

FIGURE 3-2 Forward Facing Rackmounting Brackets

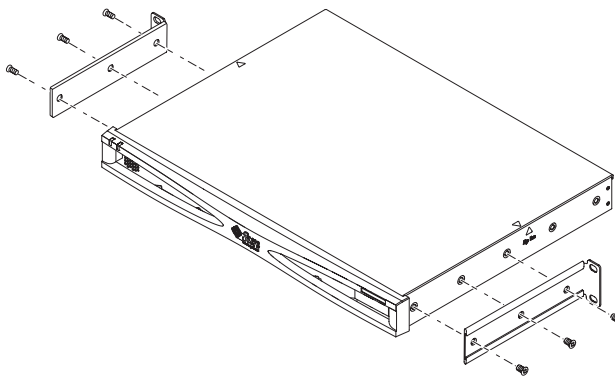

FIGURE 3-3 Rear Facing Rackmounting Brackets

▼ To Use Alternative Bracket Arrangements

1. Choose the configuration that best suits your installation.
2. Reposition the rackmounting brackets on the side of the server.
3. Position the server in the rack and tighten the screws.

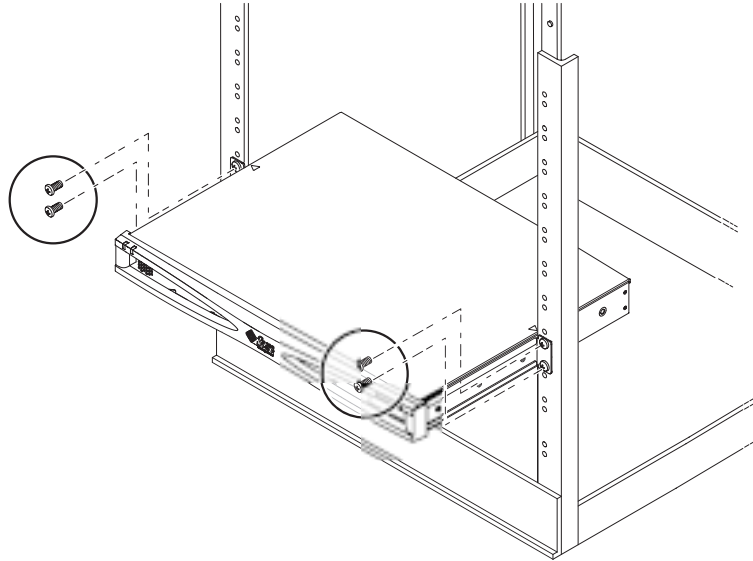

FIGURE 3-4 Alternative Rackmounting Position

4. Attach the cables (see Chapter 4).

Connecting the Cables

This chapter provides information on connecting the Ethernet, serial, and power cables to a Netra X1 server. It also describes the types of serial connection that you can make to the server. The chapter contains the following sections:

- “Connecting the Cables to the Server” on page 16
- “Setting Up Serial Connections” on page 18

Connecting the Cables to the Server

Before following the instructions in this section, make sure you have installed the server into a rack or cabinet (see Chapter 3).

The server's ports are arranged and numbered as in FIGURE 4-1.

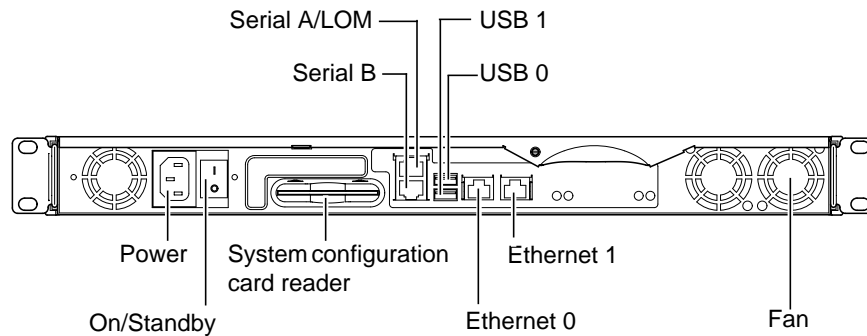

FIGURE 4-1 The Server's Back Panel

▼ To Connect the Cables to the Server

1. Connect the power cord.

2. Connect at least one serial device.

For more information, see “Setting Up Serial Connections” on page 18.

If you want to use the server's remote monitoring and management facilities, make sure you use the port labeled Serial A/LOM.

3. Connect the server to at least one Ethernet hub.

You can connect to a maximum of two Ethernet hubs.

4. Connect the server to a maximum of two USB devices.

5. If you intend to configure the server directly from a dumb terminal or a Sun workstation, insert the serial cable into the DB-25 adapter that was packaged with your server.

When you have done this, connect the adapter to the DB-25 serial connector on the terminal or on the Sun workstation.

Refer to Chapter 5 for information about powering on the system.

Refer to Chapter 8 for information about any software patches you might need to apply.

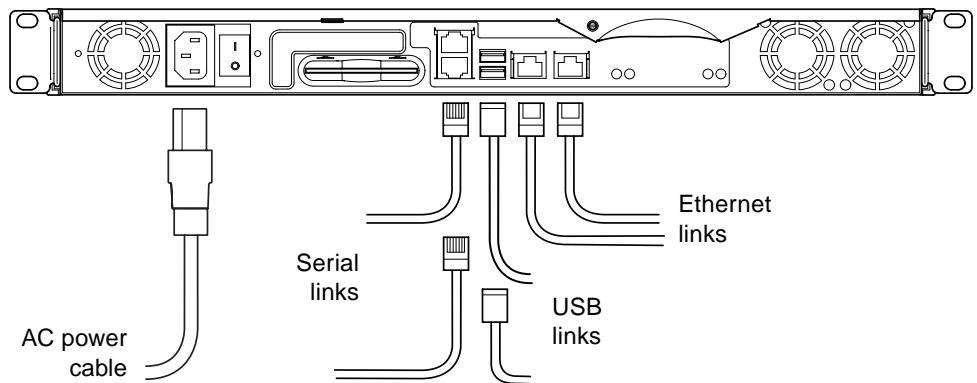

FIGURE 4-2 Connecting Cables to the Netra X1 Server



Caution – AC-powered Sun products are designed to work with single-phase power systems that have a grounded neutral conductor. To reduce the risk of electric shock, do not connect Sun products to any other type of power system. Contact your facilities manager or a qualified electrician if you are not sure what type of power is supplied to your building.



Caution – Your AC-powered Sun product is packaged with a grounding type (three-wire) power cord. To reduce the risk of electric shock, always connect the cord to a grounded outlet.

Setting Up Serial Connections

To perform the initial configuration when you install the Netra X1 server, and also for ongoing monitoring and management of the system, you will need to use at least one of the serial ports on the system's back panel. You can connect either or both serial ports to any of the following devices:

- **A Sun workstation or dumb terminal**

For this connection you can use the standard RJ-45 patch cable supplied with the server, but you need to insert one end into the DB-25 adapter also supplied.

- **A terminal server (or patch panel connected to a terminal server)**

The pinouts for the server's serial ports correspond with the pinouts for the RJ-45 ports on the Asynchronous Serial Interface Breakout Cable supplied by Cisco for use with the Cisco L2511 terminal server. For terminals from other manufacturers, you may need to make your own crossover (null-modem) cable (see "To Connect to a Terminal Server" on page 18).

- **A modem**

For this connection you can use the standard RJ-45 patch cable supplied with the server, but you need to insert one end into the DB-25 adapter which is also supplied with the server. Do not use the Serial A/LOM port for binary data transfers. To perform any task other than an ASCII transfer, use the port labeled Serial B.

▼ To Connect to a Terminal Server

The serial ports on the Netra X1 server are DTE ports. If you connect these to other DTE ports, then the cabling between them must perform a *crossover*.

The pinouts for the server's serial ports correspond with the pinouts for the RJ-45 ports on Cisco terminal servers. This means that if you are using a Cisco L2511 Terminal Server (and you are connecting the Netra X1 server to it using the Cisco Asynchronous Serial Interface Breakout Cable), you have two connection options:

- Connect the breakout cable directly to the Netra X1 server.
- Connect the breakout cable to a patch panel and use the straight-through patch cable (supplied by Sun) to connect the patch panel to the server (see FIGURE 4-3).

Note – You do not have to use the Netra X1 server with a Cisco terminal server. For other terminal servers, check the manufacturer’s documentation to see if the pinouts of the serial ports on the terminal server match the pinouts of the Netra X1 server’s serial ports. If they do not, you need to make a cable that takes each pin on one of the Netra X1 server’s serial ports to the corresponding pin in the terminal server’s serial port.

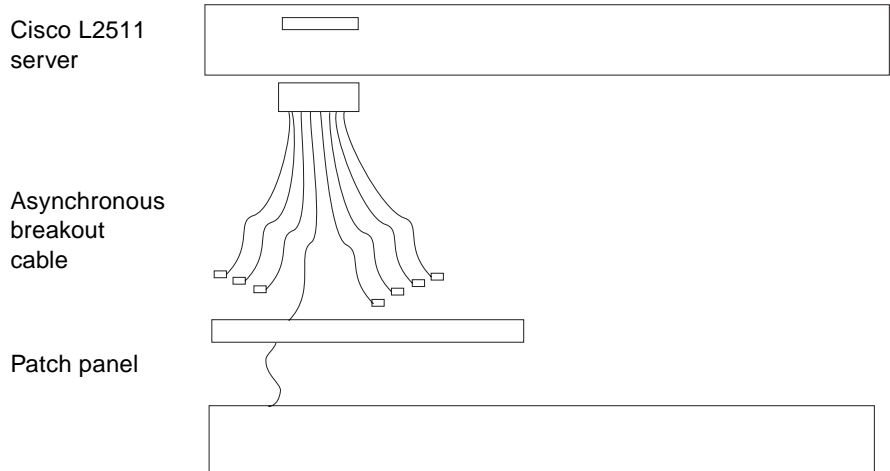

FIGURE 4-3 Patch Panel Connection Between a Cisco L2511 Server and a Netra X1 Server

Note – When viewed from the back of the server, the pin arrangement of the RJ-45 ports is as shown below.

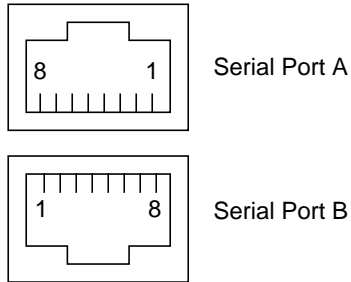

FIGURE 4-4 Serial Port Pins 1 to 8

TABLE 4-1 Pin Crossovers for Connecting to a Typical Terminal Server

Netra X1 Serial Port (RJ-45 Connector) Pin	Terminal Server Serial Port Pin
Pin 1 (RTS)	Pin 1 (CTS)
Pin 2 (DTR)	Pin 2 (DSR)
Pin 3 (TXD)	Pin 3 (RXD)
Pin 4 (Signal Ground)	Pin 4 (Signal Ground)
Pin 5 (Signal Ground)	Pin 5 (Signal Ground)
Pin 6 (RXD)	Pin 6 (TXD)
Pin 7 (DSR)	Pin 7 (DTR)
Pin 8 (CTS)	Pin 8 (RTS)

Using a DB-25 Adapter for the Serial Link

The pinouts are identical for the RJ-45 serial ports on the Netra X1 server. To connect to a Solaris `tip` session or to a `vt100` terminal, you need to use either the DB-25 (25-Pin DSUB Male to 8-POS RJ-45 Female) adapter that is supplied by Sun (part no. 530-2889) with your system, or an alternative adapter that performs the same pin crossovers. The Sun-supplied DB-25 adapter enables you to connect to any Sun system. The crossovers it performs are listed in TABLE 4-2.

Note – If you need to set up a modem connection to the Netra X1 server, you must use the port labeled Serial B. The Serial A/LOM port does not assert the required constant DTR signal.

TABLE 4-2 Pin Crossovers in the Sun DB-25 (25-Pin) Adapter

Serial Port (RJ-45 Connector) Pin	25-Pin Connector
Pin 1 (RTS)	Pin 5 (CTS)
Pin 2 (DTR)	Pin 6 (DSR)
Pin 3 (TXD)	Pin 3 (RXD)
Pin 4 (Signal Ground)	Pin 7 (Signal Ground)
Pin 5 (Signal Ground)	Pin 7 (Signal Ground)
Pin 6 (RXD)	Pin 2 (TXD)
Pin 7 (DSR)	Pin 20 (DTR)
Pin 8 (CTS)	Pin 4 (RTS)

Using a DB-9 Adapter for the Serial Link

To connect to a terminal that has a 9-pin serial connector, connect one of the Netra X1 server's serial ports to a DB-9 (9-pin) adapter that performs the pin crossovers listed in TABLE 4-3.

TABLE 4-3 Pin Crossovers for a DB-9 (9-Pin) Adapter

Serial Port (RJ-45 Connector) Pin	9-Pin Connector
Pin 1 (RTS)	Pin 8 (CTS)
Pin 2 (DTR)	Pin 6 (DSR)
Pin 3 (TXD)	Pin 2 (RXD)
Pin 4 (Signal Ground)	Pin 5 (Signal Ground)
Pin 5 (Signal Ground)	Pin 5 (Signal Ground)
Pin 6 (RXD)	Pin 3 (TXD)
Pin 7 (DSR)	Pin 4 (DTR)
Pin 8 (CTS)	Pin 7 (RTS)

Serial Connection Settings

The settings you need to use for a serial connection are listed in TABLE 4-4. If you need to perform binary data transfers (that is, transfers of anything more than simple ASCII character streams), use the Serial B port. Communication on the Serial A/LOM port is subject to interruption by the Lights Out Management (LOM) device (see “Introduction to Lights-Out Management” on page 36).

TABLE 4-4 Settings for Connecting to the Serial A/LOM or Serial B Port

Parameter	Setting
Connector	Serial A/LOM or Serial B (use Serial B for binary data transfers)
Rate	9600 baud
Parity	No
Stop bits	1
Data bits	8

Powering On the Netra X1 Server

This chapter explains how to configure the server, power it on, and use the Power (On/Standby) switch. The chapter contains the following sections:

- “Preparing to Configure the Server” on page 24
- “Powering On the Server for the First Time” on page 25
- “Using the Power (On/Standby) Switch” on page 30

Preparing to Configure the Server

To perform the initial configuration of the Netra X1 server, set up a serial connection via the port labeled Serial A/LOM on the server's back panel (see Chapter 4). Make sure you have the server's power cord connected.

▼ To Configure Using a Terminal Server

- To access the Netra X1 server from a Sun workstation via a terminal server, open a terminal session on the Sun workstation, and type:

```
# telnet IP-address-of-terminal-server port-number
```

For example, for a Netra X1 server connected to port 10000 on a terminal server whose IP address is 192.20.30.10, you would type:

```
# telnet 192.20.30.10 10000
```

▼ To Configure From a Terminal or Workstation

- To access the Netra X1 server from a dumb terminal, set up a connection between the terminal and the Netra X1 server.
- To access the Netra X1 server from a Sun workstation directly connected to the server, set up the connections between the devices, then run a terminal session by typing:

```
# tip /dev/term/a -9600
```

The `tip` command above assumes that your console is using its `ttya` serial port. If you later configure your console to use `ttyb`, you must type the following to set up a `tip` session:

```
# tip /dev/term/b -9600
```

For information about dedicating the console to Serial B, see “Managing the Netra X1 Server From the lom> Prompt” on page 35).

Powering On the Server for the First Time

When the Netra X1 server is connected to mains electricity, it is always either fully powered or in standby power mode. To completely remove power from a server, you must disconnect its power cable. The methods referred to in this section and the next section power the server on, or return it to standby power mode. They cannot be used to power the server off completely.

- using lom> prompt commands
- using the rocker switch on the server’s back panel.

For more information, see “Using the Power (On/Standby) Switch” on page 30.

▼ To Power On With the Server’s Details Registered at a Name Server

Note – Follow the instructions in this section only if you have a name server installed on your network. For instructions on using a name server to automate the process of configuring the Solaris operating environment on multiple servers, refer to the *Solaris 8 Advanced Installation Guide* which accompanies the Solaris 8 CDs.

1. **Connect the server to the power supply but do not power it on.**
2. **Set up a serial connection to the Serial A/LOM port and also a connection to at least one Ethernet hub (as described in Chapter 4).**

3. At the console `lom>` prompt, type the following command to power on the server:

```
lom> poweron
```

For more information about the `lom>` prompt and the commands that are available from it, see Chapter 6.

During booting you will be prompted for certain information. The first question the system asks you is what language you want it to use when prompting you for the rest of the information.

4. Specify a language.
5. Specify your locale.
6. Specify the type of terminal you are using to communicate with the Netra X1 server.
7. Specify whether you need IPv6 enabled, and then follow the instructions on the screen.
8. Specify whether you want to enable the Kerberos Security mechanism, and then follow the instructions on the screen.
9. Confirm the information you have typed.
10. Specify time and date information.
11. Give a password (if any) for users logging in as root.
12. When asked if you want the server to perform Automatic Power Saving Shutdown, answer No.

Note – If you answer Yes, the server will automatically put itself into Standby mode after a period of idleness.

When you have provided the information the system needs, it will boot.

▼ To Power On Without the Server's Details Registered at a Name Server

Follow the instructions in this section if you do not have a Name Server configured on your network.

Read these instructions through before you follow them, to find out the information for which the system will prompt you when you start it for the first time.

1. **Connect the server to the power supply but do not power it on.**
2. **Set up a serial connection to the Serial A/LOM port and also a connection to at least one Ethernet hub (as described in Chapter 4).**
3. **At the `lom>` prompt, type the following command to power on the server:**

```
lom> poweron
```

For more information about the `lom>` prompt and the commands that are available from it, see Chapter 6.

During booting you will be prompted for certain information. The first question the system asks you is what language you want it to use when it prompts you for the information it needs.

4. **Specify a language.**
5. **Specify your locale.**
6. **Specify the type of terminal you are using to communicate with the Netra X1 server.**
7. **Specify whether the IP address is to be configured manually or by DHCP.**
If manually, specify an IP address when prompted.
8. **Specify which of the Ethernet ports you intend to use as the primary Ethernet connection.**
For the port labeled Net0, specify `dmfe0`. For the port labeled Net1, specify `dmfe1`.
9. **Specify a host name for the server.**
10. **Specify whether you need IPv6 enabled, and then follow the instructions on the screen.**
11. **Specify whether you want to enable the Kerberos Security mechanism, and then follow the instructions on the screen.**
12. **Specify the name service you want the server to use.**
13. **Specify the name of the domain of which the server will be a part.**
14. **Specify whether you want the system to search the network for a name server or whether you want it to use a particular name server.**
15. **If you chose to use a particular name server, specify the host name and IP address of the name server.**

16. Specify whether the Netra X1 server is to be part of a subnet.
17. Specify a Netmask for the server.
18. Confirm the information you have typed.
19. Specify time and date information.
20. When prompted, give a password (if any) for users logging in as root.
21. When asked if you want the server to perform Automatic Power Saving Shutdown, answer No.

Note – If you answer Yes, the server will automatically put itself into Standby mode after a period of idleness.

When you have provided the information the system needs, it will boot.

▼ To Power On a Standalone Server for the First Time

1. Connect the server to the power supply but do not power it on.
2. Set up a serial connection using the Serial A/LOM port (as described in Chapter 6).
3. At the `lom>` prompt, type the following command to power on the server:

```
lom> poweron
```

For more information about the `lom>` prompt and the commands that are available from it, see Chapter 8.

4. Specify a language.
5. Specify your locale.
6. Specify the type of terminal you are using to communicate with the Netra X1 server.
7. When prompted to indicate whether you want the server to be networked, specify No.
8. Specify a Host Name for the server.
9. Confirm the information you have given.

10. Specify the date and time information.
11. When prompted, give a password (if any) for users logging in as root.
12. When asked if you want the server to perform Automatic Power Saving Shutdown, answer No.

Note – If you answer Yes, the server will automatically put itself into Standby mode after a period of idleness.

The system will boot when you have provided it with the information it needs.

▼ To Clear Your Configuration and Start Again

If you want to start the power on process again, as if from a previously unused server, you must clear the configuration of the server.

- If you are at the `lom>` prompt, go to the `ok` prompt by typing:

```
lom> break
```

1. Boot the server into the Solaris environment by typing:

```
ok boot
```

2. At the Solaris prompt, type:

```
# sys-unconfig
```

3. When prompted to confirm that you want to create a 'blank' server, type `y`.
4. When the server has unconfigured itself, type the LOM escape sequence. By default, this is:

```
# #.
```

When the `lom>` prompt appears, follow the instructions in either of the following sections:

- “To Power On With the Server’s Details Registered at a Name Server” on page 25 or
- “To Power On Without the Server’s Details Registered at a Name Server” on page 26.

Using the Power (On/Standby) Switch



Caution – The power switch (on the back panel of the Netra X1 server) is not an On/Off switch, it is an On/Standby switch. It does not isolate the equipment.

The power (On/Standby) switch of the Netra t1 server is a rocker type, momentary action switch. It controls only low-voltage signals; no high-voltage circuits pass through it. This means that the main method of connecting or disconnecting power is by inserting or removing the power supply cord. The server contains no integral circuit breakers. To isolate it, you must break all connections to it. If you do not do this by removing the power supply cord, you must instead open all external circuit breakers.

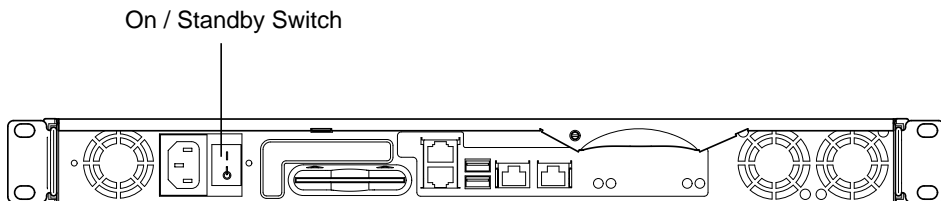

FIGURE 5-1 Netra X1 Server Power (On/Standby) Switch

The symbols on the switch are:

On

- Press to apply power to the server.



Standby

- Press for less than four seconds to initiate an orderly shutdown of the system into Standby mode.

- Press and hold down for more than four seconds to leave only the LOM and certain battery backed functions running.

PART II Remote and Local Management

Managing the Netra X1 Server From the `lom>` Prompt

This chapter introduces the LOMlite2 Lights-Out Management (LOM) facilities available for the Netra X1 server and describes how to use the `/usr/sbin/lom` utility, which provides a user interface to the device. The chapter contains the following sections:

- “Introduction to Lights-Out Management” on page 36
- “Powering On or Resetting the Server From the LOMlite2 Shell” on page 36
- “Monitoring the Server From the LOMlite2 Shell” on page 41
- “Setting Up LOMlite2 Privileges for Named Users” on page 46
- “Setting the LOMlite2 Device’s Configurable Variables” on page 50
- “Separating LOMlite2 From the Console on the Serial A/LOM Port” on page 52
- “Viewing Event Reports That LOMlite2 Sends to `syslogd`” on page 53
- “LOMlite2 Shell Command List” on page 54
- “Checking the Fans” on page 56

Note – For information about how to configure the LOMlite2 device-driver, see Appendix A.

Introduction to Lights-Out Management

LOMlite2 is contained on the system board in the Netra X1 server. It provides management facilities that enable you to detect and respond quickly to problems, which is particularly useful for managing servers that are deployed in a “lights-out” environment. However, you can also use them to perform quick onsite management tasks at a locally connected terminal.

You can use the LOM facilities remotely or from a local connection to:

- Power the server on or to standby mode.
- Monitor the server’s temperature and the status of its power supply, fans, internal voltage rails, fault LED, and alarms, even when the server is in standby mode.
- Turn a Fault LED on.
- Configure the server to restart automatically after a lockup.

Note – The Netra X1 server is supplied with the Solaris 8 (10/00) operating environment installed and with the supplementary LOM software described in this chapter and Chapter 7 also installed. This software enables you to manage the Netra X1 server locally or remotely. If you ever need to reinstall the Solaris 8 environment and you want to use the LOM facilities, you must also reinstall the Netra X1 software from the CD titled *Software Supplement for the Solaris 8 Operating Environment*. This CD is included with the Solaris 8 software CDs. The LOM software is in the following directory: `/Netra_t_Lights_Out_Management_2.0`. The three packages you need are the `SUNWlomm`, `SUNWlomr`, and `SUNWlomu`.

Powering On or Resetting the Server From the LOMlite2 Shell

To use the LOM facilities either remotely or locally, you must establish a terminal connection to the Serial A/LOM port on the server. For details on how to do this, see “Setting Up Serial Connections” on page 18.

There are two ways of interrogating the LOMlite2 device or of sending it commands to perform. One is by issuing LOMlite2 commands from the `lom>` shell prompt. This chapter explains how to do this. The other is by issuing LOMlite2-specific Solaris commands from the console prompt. For information about the LOMlite2 commands that are available with the Solaris 8 (10/00) operating environment, see Chapter 7.

When the Netra X1 server is connected to a power supply, it is always either fully powered or in standby mode. To remove power entirely from the server you must disconnect its power cables or open all external circuit breakers. The methods referred to in this chapter for powering the server on and off by using `lom>` prompt commands are methods either of powering the server on or of returning it to standby power mode. The `poweroff` command does not power the server off completely.

Note – All commands that involve powering on or off, resetting, or specifying the boot mode of the server require you or the named user to have `r`-level LOMlite2 user permission. If you have not set up any named users of the LOMlite2 device, then you have `r`-level permission by default. If you have set up one or more named users, then you must explicitly give them `r`-level permission to use these commands. For more information about user privileges, see “Setting Up LOMlite2 Privileges for Named Users” on page 46.

▼ To Power the Server On or to Power Down to Standby Mode

If the server you are connected to is not powered on but is connected to a power supply, you will see the `lom>` prompt at your terminal. Remember that the LOMlite2 uses standby power and so remains active even when the server is not powered on.

- **To power on the server, type:**

```
lom> poweron
```

- **To power the server down to standby mode, type:**

```
lom> poweroff
```

▼ To Display the lom> Prompt

When you connect a terminal to the Serial A/LOM port, you will see the lom> prompt only if the server is powered off. If it is powered on and it has not already been put into LOM mode, it will display the console prompt.

- To display the lom> prompt, type the following LOMlite2 escape sequence:

```
# #.
```

When you type the LOMlite2 escape sequence, the LOMlite2 device takes control of the Serial A/LOM port and the lom> prompt appears on your terminal screen. You can type the LOMlite2 escape sequence at any time.

Note – If you are at the console and you type the first character of the LOM escape sequence (by default this is #), there is a delay of one second before the character appears on the screen. This is because the server waits to see if you type the dot (.) character next. If you do, the lom> prompt is displayed. If you do not, the # character appears on the screen.

For information about changing the first character of the LOMlite2 escape sequence, see Chapter 7.

▼ To Exit From the lom> Prompt

- To return to the Solaris console prompt from the lom> prompt, type:

```
lom> console
```

Note – If you have the Serial A/LOM port dedicated to the LOMlite2 device (instead of shared between the LOMlite2 and the console), this command will have no effect. For information about dedicating the Serial A/LOM port to the LOMlite2 device, see “Separating LOMlite2 From the Console on the Serial A/LOM Port” on page 52.

Note – If you have set up named users of the LOMlite2 device, the users need `c`-level permission to use the `console` command. Without it, the command will not work. For more information about setting up user permissions, see “Setting Up LOMlite2 Privileges for Named Users” on page 46.

▼ To Reset the Server

- To reset the server, type:

```
lom> reset
```

- To perform a limited reset affecting the processor only, type:

```
lom> reset -x
```

The `-x` option generates the equivalent of an externally initiated reset (XIR) of the server. You must have `r`-level permission to use this command. (For information about user authorization levels, see “Setting Up LOMlite2 Privileges for Named Users” on page 46.) The `-x` option takes the server into OpenBoot™ PROM mode and causes it to display the `ok` prompt. It is useful for driver or kernel debugging, because most of the contents of the server’s memory and registers are preserved. The server does not automatically return to the Solaris environment when you reset it using the `-x` option. Instead, you must reboot it from the `ok` prompt.

▼ To Display the `ok` or `kadb` Prompt

To display the `ok` or `kadb` prompt, type the following at the `lom>` prompt:

```
lom> break
```

Note – If the Serial A/LOM port is dedicated to the LOMlite2 device, this command will have no effect. For information about dedicating the Serial A/LOM port to the LOMlite2 device, see “Separating LOMlite2 From the Console on the Serial A/LOM Port” on page 52. To use the `break` command, you must have `c`-level LOMlite2 user privileges. For more information, see “Setting Up LOMlite2 Privileges for Named Users” on page 46.

Controlling the Server's Booting Behavior

The LOMlite2 shell includes a `bootmode` command:

```
bootmode [-u][normal|forth|reset_nvram|diag|skip_diag]
```

This command enables you to dictate the behavior of the server after a reset. Its functionality is identical to that available on Sun keyboards with the L1 key combinations. (However, the `bootmode` command is provided because the L1 key combinations are not available for the Netra X1 server: you cannot use them from a keyboard that is connected to the server with a serial link.)

You must have `r-level` LOMlite2 permission to use the `bootmode` command. For information about user privileges, see “Setting Up LOMlite2 Privileges for Named Users” on page 46.

Boot Modes Available

If you use the `bootmode` command without arguments, the LOMlite2 device reports only the current boot mode. The boot modes available are listed in TABLE 6-1.

TABLE 6-1 Boot Modes

Mode	Description
<code>-u</code>	This option does not represent a boot mode. However, if you have previously dedicated the Serial A/LOM port to LOMlite2 and you now want to share the port between the console and LOMlite2, you can use the <code>-u</code> option. It is a quick alternative to the procedure described for sharing the Serial A/LOM port in the section “Separating LOMlite2 From the Console on the Serial A/LOM Port” on page 52.
<code>normal</code>	In this mode, the server boots using your OpenBoot PROM settings. To cause this parameter to take effect, you must reset the server after using the <code>bootmode</code> command at the <code>lom></code> prompt.
<code>forth</code>	In this mode, the server does not boot to the Solaris environment but stops the boot cycle at the <code>ok</code> prompt. The command is equivalent to the L1-F key combination for Sun keyboards. To cause the parameter to take effect, you must use the <code>bootmode forth</code> command at the <code>lom></code> prompt and then reset the server. (It is only when the server resets that it reads the new <code>forth</code> parameter from the LOMlite2 device.)

TABLE 6-1 Boot Modes

Mode	Description
<code>reset_nvram</code>	In this mode, the server returns all NVRAM data to its default setting. The command is equivalent to the L1-N key combination for Sun keyboards. To cause the parameter to take effect, you must reset the server after using the <code>bootmode</code> command at the <code>lom></code> prompt.
<code>diag</code>	In this mode, the server performs full self-diagnostics as part of the boot process. The command is equivalent to the L1-D key combination for Sun keyboards. To cause the parameter to take effect, you must power off and then power on the server within 10 minutes of using the <code>bootmode</code> command at the <code>lom></code> prompt.
<code>skip_diag</code>	In this mode, the server skips the diagnostics part of the boot process. To cause the parameter to take effect, you must power off and then power on the server within 10 minutes of using the <code>bootmode</code> command at the <code>lom></code> prompt.

Monitoring the Server From the LOMlite2 Shell

This section describes the commands that enable you to check the status of the server and the components monitored by the LOMlite2 device. It also describes how to view the events stored in the LOMlite2 device's event log.

▼ To Check How Long the Server Has Been Running

- To find out how long it is since the last system reset, type:

```
lom> date
```

or:

```
lom> showdate
```

▼ To Check the Current Status of All Components

- To see the current status of all the components monitored by the LOMlite2 device, type:

```
lom> environment
```

CODE EXAMPLE 6-1 shows some sample output from the `environment` command. In this example, all the components are running normally and none are faulty.

Note – For the locations of the fans, see “Checking the Fans” on page 56.

CODE EXAMPLE 6-1 Sample Output From the `environment` Command

```
lom>environment
Fault OFF
Alarm 1 OFF
Alarm 2 OFF
Alarm 3 OFF

Fans:
1 OK speed 99%
2 OK speed 95%

PSUs:
1 OK

Temperature sensors:
1 28degC OK

Overheat sensors:
1 OK

Circuit breakers:
1 OK

Supply rails:
1 OK
2 OK
3 OK
4 OK
5 OK

lom>
```

Viewing the LOMlite2 Event Log

FIGURE 6-1 shows a sample event log display. The `eventlog` command reports the last 10 events. The `loghistory` command can report up to several hundred events. Note that the first event is the oldest and that each event has a time stamp indicating the hours and minutes (and, if applicable, days) since the following:

- The LOMlite2 device was last powered off (that is, since all power to the server, including standby power, was last removed) or
- If the server has been booted since all power was last removed, then the time stamp indicates the number of days, hours, and minutes since the last reboot.

▼ To View the Last 10 Events in the Event Log

- **Type:**

```
lom> show eventlog
```

▼ To View the Entire Event Log

- **Type:**

```
lom> loghistory [pause x] [level y]
```

where *x* is the number of lines you want to display before pausing, and *y* is the severity level of the events you want to see. By default, the `loghistory` command displays all the events in the log and does not pause the display.

If you specify a severity level, you will see reports for the level you specify and above. For example, if you specify level 2, you will see reports of level 2 and level 1 events. If you specify level 3, you will see reports of level 3, level 2, and level 1 events.

If you do not specify a level, you will see events for all levels.

For more information about severity levels, see “Viewing Event Reports That LOMlite2 Sends to syslogd” on page 53.

Each entry in the log includes the time of the event, the server's host name, a unique identifier for the event, and a user-friendly text message describing the event.

Note – The LOMlite2 device's Event Log is never cleared, and it can contain several hundred entries. Events are stored from the very first time the server boots. Eventually the buffer might become full, but when this happens, the LOMlite2 device will start again at the beginning of the buffer, overwriting the earliest events.

▼ To View All Events From the First to the *n*th Event Logged

- **Type:**

```
lom> loghistory index +n [pause x] [level y]
```

where *n* is the number of events you want to see that have been logged since the first event in the current log, *x* is the number of lines you want to display before pausing, and *y* is the severity level of the events you want to see. By default, the `loghistory` command does not pause the display.

▼ To View All Events From the Last One Logged to the *n*th Event Before It

- **Type:**

```
lom> loghistory index -n [pause x] [level y]
```

where *n* is the number of events you want to see listed that were logged before the last event in the current log, *x* is the number of lines you want to display before pausing, and *y* is the severity level of the events you want to see. By default, the `loghistory` command does not pause the display.

- To see the last five events, type:

```
lom> loghistory index -5
+0h39m34s Alarm 1 ON
+0h39m40s Alarm 3 ON
+0h39m54s Alarm 3 OFF
+0h40m0s Alarm 1 OFF
+0h40m58s Fault LED ON
```

Verifying That a Component Has Been Fixed

If a monitored component has failed, the LOMlite2 device does not continue to report the failure. You can, however, check the status of a component, for example, after attempting to fix it.

▼ To Check the Status of a Component

- Type:

```
lom> check
```

This causes the LOMlite2 device to update the status of all the components it monitors.

Setting Up LOMlite2 Privileges for Named Users

You can specify up to four named users of the LOMlite2 device on a Netra X1 server. By default, no users are set up, and therefore no user login prompt appears when you use the LOM escape sequence.

However, if you set up one or more users, every time you use the LOM escape sequence to display the `lom>` prompt, you will be prompted for a user name and password. Therefore, one of the user accounts you set up must be for yourself.

Permissions Available for LOMlite2 Users

Four areas of authorization are available for named users. By default, all four are open to them. However, if you specify any (using the `lom> userperm` command), only the one or ones that you specify will be available.

The four areas of authorization available by default are:

- **Console permission (c-level)**
This enables the named user to exit from the `lom>` prompt to the Solaris prompt (if the Serial A/LOM port is shared between the LOMlite2 and the console).
- **User Administration permission (u-level)**
This enables the named user to add and delete users and alter their permissions.
- **Administration permission (a-level)**
This enables the named user to change the LOMlite2 device's configuration variables (see "Introduction to Lights-Out Management" on page 36).
- **Reset permission (r-level)**
This enables the user you have named to reset the server and to power it on and off using the LOMlite2 device.

For information about how to specify one or more of these areas of authorization for a named user, see "To Specify Permissions for a Named User" on page 49.

▼ To Create a LOMlite2 User Account

- **Type:**

```
lom> useradd username
```

where the *username* is up to eight characters long, begins with an alphabetic character, and contains at least one lowercase alphabetic character. You can use any of the following characters in the user name:

- Alphanumeric
- Period (.)
- Underscore (_)
- Hyphen (-)

Note – You must have User Administration (u-level) authorization to add a user (see “Permissions Available for LOMlite2 Users” on page 46). If you have not added any users, you have a-level and all other levels of authorization by default.

▼ To Specify the Password for a LOMlite2 User Account

- **Type:**

```
lom> userpassword username
```

where the *username* is the name of a LOMlite2 user account that already exists.

Note – You must have User Administration (u-level) authorization to set a password for a user (see “Permissions Available for LOMlite2 Users” on page 46).

▼ To View the Details of a LOMlite2 User Account

- **Type:**

```
lom> usershow username
```

where the *username* is the name of an existing LOMlite2 user account.

Note – You must have User Administration (u-level) authorization to view the details of a LOMlite2 user account (see “Permissions Available for LOMlite2 Users” on page 46).

▼ To Change Your Own User Password

1. To change the password for the account you are currently logged into, type:

```
lom> password
```

2. When prompted, specify the current password.
3. When prompted, specify the new password you want to use.
4. Specify the new password again to confirm it.

▼ To Delete a LOMlite2 User Account

- **Type:**

```
lom> userdel username
```

where the *username* is the name of an existing LOMlite2 user account.

Note – You must have User Administration (a-level) authorization to delete a user account (see “Permissions Available for LOMlite2 Users” on page 46).

If you delete all the users you have set up, you will no longer see the login prompt when you go to the lom> prompt.

By default, all four areas of authorization are available to each named user you set up. You can limit users to a particular area or areas of authorization by specifying permissions for a named user.

▼ To Specify Permissions for a Named User

- **Type:**

```
lom> userperm username [c][u][a][r]
```

You can specify:

- **No parameters**
This makes all four areas available to the named user.
- **All four parameters** (for example, `userperm cuar`)
This also makes all four areas available to the named user.
- **One, two, or three parameters**
This makes only the parameter or parameters you specify available.

The parameters are:

- **c**
This stands for “console permission”. It enables the named user to exit from the `lom>` prompt to the Solaris prompt (as long as the Serial A/LOM port is shared between the LOMlite2 and the console).
- **u**
This stands for “user administration permission”. It enables the named user to add and delete users and alter their areas of authorization by using the `userperm` command.
- **a**
This stands for “administration permission”. It enables the named user to change the LOMlite2 device’s configuration variables (see “Setting the LOMlite2 Device’s Configurable Variables” on page 50).
- **r**
This stands for “reset permission”. It enables the user you have named to reset the server and to power it on and off using the LOMlite2 device.

▼ To Quit a LOMlite2 Named User Session

- **Type:**

```
lom> logout
```

This returns you to the LOMlite2 login prompt.

Setting the LOMlite2 Device's Configurable Variables

There are some variables that you can use as arguments to the `set` command in the LOMlite2 shell. The `set` command duplicates the `faulton`, `faultoff`, `alarmon`, and `alarmoff` commands by taking them as arguments. It also takes the argument `event_reporting`, which enables you to stop the LOMlite2 device from sending event reports to the Serial A/LOM port.

Note – To be able to run the commands described in this section, a named user must have a-level permission. For more information, see “Setting Up LOMlite2 Privileges for Named Users” on page 46.

▼ To Turn the Fault LED On and Off

- **To turn the Fault LED on by setting the `faulton` variable, type:**

```
lom> set faulton
```

- **To turn the Fault LED off by setting the `faultoff` variable, type:**

```
lom> set faultoff
```

▼ To Set the Alarm

- Turn the alarm on by typing:

```
lom> set alarmon n
```

where *n* is the number of the alarm you want to turn on: 1, 2, or 3.

- Turn the alarm off by typing:

```
lom> set alarmoff n
```

where *n* is the number of the alarm you want to turn off: 1, 2, or 3.

▼ To Stop LOMlite2 Sending Event Reports to the Serial A/LOM Port

- Enable event reporting by typing:

```
lom> set eventreporting on
```

Note – This is the equivalent of using the `lom -E on` command from the Solaris shell. For more information, see “To View the Event Log (lom -e)” on page 63.

- Disable event reporting by typing:

```
lom> set eventreporting off
```

Note – This is the equivalent of using the `lom -E off` command from the Solaris shell. For more details, see “To Stop LOMlite2 From Sending Reports to the Serial A/LOM Port (lom -E off)” on page 68.

Separating LOMlite2 From the Console on the Serial A/LOM Port

By default, the LOMlite2 device shares the Serial A/LOM port with the console, and when it has an event report to send, it takes control of the Serial A/LOM port itself, interrupting any console activity you are performing. To prevent the LOMlite2 device from interrupting the console, either turn serial event reporting off (see Chapter 7), or dedicate the Serial A/LOM port to the LOMlite2 device and use the Serial B port for console activity. The next section, “To Dedicate Serial A/LOM to LOMlite2” on page 52, gives more detail.

The advantages of dedicating the Serial A/LOM port to the LOMlite2 device and using Serial B as your console port include:

- Preserving the ability to power on or reset the server (from the `lom>` prompt on Serial A/LOM) even if for any reason you lose access to Solaris on your console port (Serial B).
- Capturing all LOMlite2 events passively on a terminal connected to the dedicated LOM port (Serial A/LOM). Note, however, that if you dedicate the Serial A/LOM port to the LOMlite2 device, you cannot use the `console` command to quit the LOMlite2 shell. Instead, for access to the Solaris environment, you must connect to the server using the Serial B port.
- Preventing a user with console access from using the LOMlite2 escape sequence to exit the Solaris environment and access the LOMlite2 shell. If you dedicate the Serial B port to the console, users cannot bring up the LOMlite2 shell, which means that they cannot interrogate or reconfigure the LOMlite2 device.
- Performing binary data transfers. To perform any task other than an ASCII transfer, you must use the Serial B port.

▼ To Dedicate Serial A/LOM to LOMlite2

1. Set up console connections to both the Serial A/LOM port and the Serial B port.
2. At the Solaris prompt, type:

```
# eeprom input-device=ttyb
# eeprom output-device=ttyb
# reboot
```

The Serial B port (ttyb) is now your console port. The Serial A/LOM port remains in the control of the LOMlite2 device.

▼ Sharing Serial A/LOM Between LOMlite2 and the Console

Note – By default, the Serial A/LOM port is shared by the LOMlite2 device and the console. Therefore, you should follow the instructions in this section only if you have configured the server by using the instructions in the previous section (“To Dedicate Serial A/LOM to LOMlite2” on page 52) and you now want to share the Serial A/LOM port between LOMlite2 and the console.

1. Set up console connections to both the Serial A/LOM port and the Serial B port.
2. At the Solaris prompt, type:

```
# eeprom input-device=ttya
# eeprom output-device=ttya
# reboot
```

The Serial A/LOM port (ttya) is now shared between the LOMlite2 device and the console.

Viewing Event Reports That LOMlite2 Sends to syslogd

The LOMlite2 device monitors the status of the fans, supply rails, temperature, and power supply even when the server is powered off (the LOMlite2 device operates on standby power). If it detects a fault, it turns on the Fault LED on the server’s front and back panels and stores a report in an event log, which resides in memory on the LOMlite2 device. When the Solaris environment is running, the LOMlite2 device also sends event reports to `syslogd`. The `syslogd` handles these in the way it has been configured to handle event reports. This means that by default it sends them to the console and stores them in:

```
/var/adm/messages
```

In this file, the reports are displayed with a label identifying them as `lom` reports and indicating their severity. In descending order, the levels of severity are:

1. Fatal

These events might indicate, for example, exceeded temperature thresholds or supply rail failures. Fatal events can cause the server to shut itself down.

2. Warning

These events might indicate fans turning too slowly, the Fault LED having been turned on, or the System Configuration Card having been removed. They are not events that cause the server to shut down, but they do require immediate attention.

3. Info

These events are most likely to inform you that some problem is now OK. For example, if you reinsert the System Configuration Card, the LOMlite2 device will generate an event to say that the System Configuration Card has been restored.

4. User

User level events indicate the activity of named users whom you have authorized to access the LOMlite2 device. For example, an event is generated when a user logs in or out.

LOMlite2 Shell Command List

The commands you can use from the `lom>` prompt are listed in TABLE 6-2.

TABLE 6-2 LOM Commands

Command	Description
<code>alarmoff n</code>	Sets alarm <i>n</i> off, where <i>n</i> is 1, 2, or 3. These three alarms are software flags. They are associated with no specific conditions but are available to be set by your own processes.
<code>alarmon n</code>	Sets alarm <i>n</i> on. See the description for the <code>alarmoff</code> command.
<code>break</code>	Takes the server down to the <code>ok</code> prompt.
<code>bootmode</code>	Determines the behavior of the server during the boot process.
<code>check</code>	Resets monitoring to report all failures. If a monitored component has failed, the LOMlite2 device will not continue to report the same failure. To check the status of the component, for example, after attempting to fix it, use the <code>check</code> command. This updates the status of all monitored components.

TABLE 6-2 LOM Commands (*Continued*)

Command	Description
<code>console</code>	Takes you out of the LOMlite2 shell and back to the Solaris prompt. It returns control of the serial connection to the console.
<code>environment</code>	Displays the temperature of the server and the status of the fans, the power supply, the overtemperature monitors, the supply rails and circuit breakers, the alarms, and the fault LED.
<code>faulton</code>	Sets the Fault LED to On.
<code>faultoff</code>	Sets the Fault LED to Off.
<code>help</code>	Displays the list of LOM commands.
<code>loghistory</code>	Displays all the events in the LOMlite2 device's Event Log.
<code>logout</code>	Returns named users you have set up with password access to the LOM user login prompt.
<code>poweron</code>	Powers the server on.
<code>poweroff</code>	Powers the server down to standby power mode.
<code>reset</code>	Resets the server.
<code>show model</code>	Displays the server model.
<code>show hostname</code>	Displays the server name (this command is equivalent to the Solaris <code>uname -n</code> command).
<code>show eventlog</code>	Displays the LOMlite2 device's event log. The event log is the list of the last 10 events stored in the LOMlite2 device. The most recent event is the one at the bottom of the list.
<code>show escape</code>	Displays the current LOMlite2 escape sequence.
<code>show</code>	Displays all the information available with the <code>show</code> command.
<code>useradd</code>	Adds a user to the LOMlite2 device's list of permitted users.
<code>userdel</code>	Deletes a user from the LOMlite2 device's list of permitted users.
<code>usershow</code>	Displays the details of a named user's LOMlite2 account.
<code>userpassword</code>	Sets or changes a user's password.
<code>userperm</code>	Sets the permission levels for a named user.
<code>version</code>	Displays the version number of the LOMlite2 device.

Checking the Fans

Event reports about the fans inside the server include the number of the fan to which they relate. The fans monitored are fans 1 and 2, which expel hot air from the server. For the location of the fans, see “Identifying Components” on page 87.

▼ To Check the Status of the Fans

- **Type:**

```
lom> environment
```

Managing the Netra X1 Server From the Solaris Prompt

This chapter describes how to monitor and manage the Netra X1 server with LOMlite2-specific commands in the Solaris 8 (10/00) environment. It contains the following sections:

- “Monitoring the System From the Solaris Prompt” on page 58
- “Configuring LOMlite2 to Restart the Server Automatically After a Lockup” on page 64
- “Other LOM Tasks You Can Perform From the Solaris Prompt” on page 67

Note – For information about how to configure the LOMlite2 device driver, see Appendix A.

Note – The Netra X1 server is supplied with the Solaris 8 (10/00) operating environment installed and with the supplementary LOM software (described in this chapter and in Chapter 6) also installed. This software enables you to manage the Netra X1 server locally or remotely. If you ever need to reinstall the Solaris 8 environment and you want to use the LOM facilities, you must also reinstall the Netra X1 LOM software from the CD named *Software Supplement for the Solaris 8 Operating Environment*. This CD is included with the Solaris 8 software CDs. The LOM software is in the following directory: /Netra_t_Lights_Out_Management_2.0. The three packages you need are: SUNWlomm, SUNWlomr, and SUNWlomu.

Monitoring the System From the Solaris Prompt

To use the Lights-Out Management (LOM) facilities either remotely or locally, you need a terminal connection to the Serial A/LOM port on the server (see Chapter 6).

There are two ways to interrogate LOMlite2 or to send it commands to perform:

- Use LOMlite2 commands from the `lom>` shell prompt. For information about how to do this, see Chapter 6.
- Use LOMlite2-specific Solaris commands from the Solaris prompt. These commands are described in this chapter.

All Solaris commands described in this section are available from the main Solaris `#` prompt. They run a utility called `/usr/sbin/lom`.

Where appropriate, the command lines given in this section are accompanied by typical output from the commands.

There are also manual pages for the LOMlite2 utility.

▼ To View the LOMlite2 Online Documentation

- To view the manual pages for the LOMlite2 utility, type:

```
# man lom
```

▼ To Check the Power Supply Unit (`lom -p`)

- To check whether the input lines and the output line for the power supply unit are working normally, type:

```
# lom -p
PSU:
1 OK
#
```

▼ To Check the Fan Status (`l0m -f`)

- **Type:**

```
# l0m -f
Fans:
1 OK speed 99%

#
```

Checking the Supply Rail Voltages and Internal Circuit Breakers (`l0m -v`)

The supply rails are the Netra X1 server's internal power lines. If the status of any of these is `faulty`, contact your local Sun sales representative. It means that you have either a faulty system board or a faulty PSU.

The `-v` option also displays the status of the server's internal circuit breakers. For any that have been tripped, the status will read `faulty`. The system contains three circuit breakers: one for each of the USB ports and one for the system configuration card reader.

If there is a problem with the circuit breakers or the USB port circuit breakers, remove the device connected to the relevant port and the circuit breakers will automatically recover.

If there is a problem with the circuit breaker for the system configuration card, it means either that the system configuration card is inserted incorrectly, or is broken. Insert a valid one to check.

▼ To Check the Status of the Supply Rails and Internal Circuit Breakers

- **Type:**

```
# lom -v
Supply voltages:
 1 5V status=ok
 2 3V3 status=ok
 3 +12V status=ok
 4 -12V status=ok
 5 VDD-CORE status=ok

System status flags (circuit breakers):
 1 USB0 status=ok
 2 USB1 status=ok
```

▼ To Check the Internal Temperature

- **Type:**

```
# lom -t
System Temperature Sensors:
 1 enclosure 25 degC : warning 67 degC : shutdown 72 degC

System Over-temperature Sensors:
 1 cpu status=ok
#
```

This checks the server's internal temperature, and the warning and shutdown threshold temperatures.

▼ To Check Whether the Fault LED and Alarms Are On or Off

- **Type:**

```
# lom -l
LOMlite alarm states:
Alarm1=off
Alarm2=off
Alarm3=off
Fault LED=on
#
```

Alarms 1, 2, and 3 are software flags. They are not associated with any specific conditions, but are available to be set by your own processes or from the command line. For more information, see “To Turn the Alarms On and Off (lom -A)” on page 67.

▼ To Change the LOMlite2 Watchdog Configuration (lom -w)

For full information about enabling and using the LOMlite2’s watchdog process, see “To Configure the LOMlite2 Watchdog to Restart the System After a Lockup” on page 64.

- **To find out how the LOMlite2 watchdog is currently configured, type:**

```
# lom -w
LOMlite watchdog (ASR) settings:
Watchdog=on
Hardware reset=off
Timeout=40 s
#
```

The LOMlite2 watchdog is enabled by default when the Solaris environment boots. This means that, by default, if the watchdog does not receive a “pat” for 40,000 milliseconds, it will turn on the Fault LED on the front and back panels of the system, generate a LOM event report, and, if configured to do so, perform an automatic server restart. However, although the watchdog is enabled by default when Solaris boots, the `Hardware reset` option is not. This means that the LOMlite2 device does not, by default, automatically restart the server after a lockup.

- **To configure the LOMlite2 device to perform an automatic server restart (ASR) after a lockup, you must enable the `Hardware reset` option as well as the `Watchdog` option.**

For more information, see “Configuring LOMlite2 to Restart the Server Automatically After a Lockup” on page 64.

▼ To View the Configuration of LOMlite2

- **To view the settings of all the configurable variables for the LOMlite2 device, type:**

```
# lom -c
LOMlite configuration settings:
serial escape character=#
serial event reporting=default
Event reporting level=fatal, warning & information
Serial security=enabled
Disable watchdog on break=disabled
Automatic return to console=disabled
alarm3 mode=watchdog
firmware version=3.0
firmware checksum=2983
product revision=0.0
product ID=Netra X1 200
#
```

▼ To View All the Status Data Stored by LOMlite2, Plus Details of the Device’s Own Configuration

- **Type:**

```
# lom -a
```

▼ To View the Event Log (lom -e)

- To see the event log, type:

```
# lom -e n,[x]
```

where *n* is the number of reports (up to 128) that you want to see and *x* specifies the level of reporting you require. There are four levels of event reporting:

1. Fatal events
2. Warning events
3. Information events
4. User events

If you specify a level, you will see reports for that level and above. For example, if you specify level 2, you will see reports of level 2 and level 1 events. If you specify level 3, you will see reports of level 3, level 2, and level 1 events.

If you do not specify a level, you will see reports of level 3, level 2, and level 1 events.

FIGURE 7-1 shows a sample event log display. Note that the first event is the oldest and that each event has a date stamp indicating the days, hours and minutes since the system was last booted.

```
# lom -e 10
LOMlite Event Log:
+0h0m21s host reset
9/15/2000 17:35:28 GMT LOM time reference
+0h3m20s fault led state - ON
+0h3m24s fault led state - OFF
+0h39m34s Alarm 1 ON
+0h39m40s Alarm 3 ON
+0h39m54s Alarm 3 OFF
+0h40m0s Alarm 1 OFF
+0h48m52s fault led state - OFF
+0h49m39s Fan 1 FATAL FAULT: failed
+0h50m58s fault led state - ON

# lom -e 10
```

FIGURE 7-1 Sample LOMlite2 Device Event Log (Oldest Event Reported First)

Configuring LOMlite2 to Restart the Server Automatically After a Lockup

You can configure LOMlite2 to restart the server automatically after a lockup. LOMlite2 has a watchdog process that, by default, expects to be patted every 10,000 milliseconds. If it does not receive a pat after 40,000 milliseconds (default), then LOMlite2 turns the front and back fault LEDs on and generates a LOM event report. However, it does not automatically restart the system unless you have configured it to do so.

▼ To Configure the LOMlite2 Watchdog to Restart the System After a Lockup

- Add the `-R` option to the `piocntl` command in the script file called `/etc/rc2.d/S25lom`.

This is the script that runs the LOMlite2 watchdog process:

```
# piocntl -e -c RT lom -W on,40000,10000 -R on
```

When you have done this, LOMlite2 will restart the server whenever the watchdog times out.

You can turn the option on and off from the Solaris command prompt. For more information, see “To set the Hardware Reset Option From a Script or Command (lom -R on)” on page 66.

However, as long as you have the `-R on` option set in `/etc/rc2.d/S25lom`, the `Hardware Reset` option will always be enabled when you start the system.

Enabling the LOMlite2 Watchdog Process From Your Own Script or Command (`lom -W on`)

Note – You do not normally need to do this. If you want to configure LOMlite2 to perform an automatic server restart after a lockup, see “To Configure the LOMlite2 Watchdog to Restart the System After a Lockup” on page 64. Use the `lom -W on` option on the command line or in another script file only if you have removed the `/etc/rc2.d/S25lom` script.

By default, the LOMlite2 watchdog process is enabled, and if you type `lom -W on` while the watchdog process is already running, the command will have no effect. You can run this command only if you have removed the `/etc/rc2.d/S25lom` script file, or if you have turned the watchdog off manually by using the `lom -W off` command.

The default `pioctl` command is:

```
pioctl -e -c RT lom -W on,40000,10000
```

The number 40,000 on this command line indicates the watchdog’s timeout period in milliseconds; you can specify a different number. The number 10,000 indicates its pat interval in milliseconds; again, you can specify a different number.

Note – Do not specify a watchdog timeout period of less than 5000 milliseconds. If you do, the watchdog times out frequently even though the server has not locked up.

If the watchdog process times out (in other words, if it does not receive its expected pat), the LOMlite2 device will turn on the server’s front and back Fault LEDs and generate a LOM event report. However, it will not automatically reset the system. To make it reset the system, you must use the `-R` option. For more information, see “To set the Hardware Reset Option From a Script or Command (`lom -R on`)” on page 66.

- **If you have no LOMlite2 watchdog process running already and you want the process to run, type the following, or add it to another script file:**

```
# lom -W on,40000,10000
```

- **If you want the LOMlite2 device to perform an automatic server restart after a lockup, you must include the `-R on` option in the command, as follows:**

```
# lom -W on,40000,10000 -R on
```

Note – Unless you include the `lom -W on` and `-R on` options in a script file, you must run the `lom` command every time you reboot the system if you want to use the automatic server restart facility. Otherwise the watchdog will not run, and the server will not reset after a lockup.

▼ To set the Hardware Reset Option From a Script or Command (`lom -R on`)

To make the LOMlite2 device's watchdog process trigger an automatic server restart (ASR) after a lockup, add the `-R on` option to the command in your `/etc/rc2.d/S251om` script file. This is the script that runs the watchdog. For instructions about how to do this, see "To Configure the LOMlite2 Watchdog to Restart the System After a Lockup" on page 64.

However, if for any reason you are not using the script file provided with your system (`/etc/rc2.d/S251om`) but have instead enabled the watchdog from the command line or from another script file, you can turn the `Hardware reset` option on.

- To turn the `Hardware reset` option on, type the following at the command line:

```
# lom -R on
```

- To turn the `Hardware reset` option off from the command line, type:

```
# lom -R off
```

Other LOM Tasks You Can Perform From the Solaris Prompt

This section describes how to:

- turn the alarms and Fault LEDs on and off with the `lom` command
- change the first character of the `lom` escape sequence
- stop LOMlite2 sending reports to the Serial A/LOM port
- remove driver protection from the device driver
- make the LOMlite2 interface backward compatible
- upgrade LOMlite2 firmware

▼ To Turn the Alarms On and Off (`lom -A`)

There are three alarms associated with LOMlite2. They are not associated with specific conditions but are software flags that can be set either by your own processes or from the command line.

- To turn an alarm on from the command line, type:

```
# lom -A on,n
```

where *n* is the number of the alarm you want to set: 1, 2, or 3.

- To turn the alarm off from the command line, type:

```
# lom -A off,n
```

where *n* is the number of the alarm you want to turn off: 1, 2, or 3.

▼ To Turn the Fault LED On and Off (`lom -F`)

- To turn the Fault LED on, type:

```
# lom -F on
```

- To turn the Fault LED off, type:

```
# lom -F off
```

▼ To Change the First Character of the Sequence for Escaping to the lom> Prompt (lom -X)

The character sequence #. (hash, dot) enables you to exit the Solaris prompt to the lom> prompt.

- To change the first character of this default lom escape sequence, type:

```
# lom -X x
```

where x is the alphanumeric character you want to use instead of #.

Note – If you are at the console and you type the first character of the LOM escape sequence (by default this is #), there is a delay of one second before the character appears on the screen. This is because the system waits to see if you type the dot (.) character next. If you do, the lom> prompt appears. If you do not, the # character appears. If you want to change the LOM escape character, use a character that is not included in any console commands; otherwise the delay between your striking the key and the character appearing on the screen may affect your typing at the console.

▼ To Stop LOMlite2 From Sending Reports to the Serial A/LOM Port (lom -E off)

LOMlite2 event reports can interfere with information you are attempting to send or receive on the Serial A/LOM port. By default, the Serial A/LOM port is shared by the console and LOMlite2. LOMlite2 interrupts the console whenever it needs to send an event report. To prevent LOMlite2 from interrupting the console on Serial A/LOM, turn serial event reporting off.

- To stop LOMlite2 from sending reports to the Serial A/LOM port, type:

```
# lom -E off
```

- **To turn serial event reporting on again, type:**

```
# lom -E on
```

If you want to dedicate the Serial A/LOM port to the LOMlite2 device and you want to use the Serial B port as your console port, see Chapter 6.

▼ **To Remove Driver Protection From the LOMlite2 Driver (lom -U)**

By default, the LOMlite2 driver cannot be unloaded. This is because the driver is required by the watchdog process. If you unload the driver and you have configured the system to restart when the watchdog times out, the watchdog will time out, causing a system reset. For information about configuring the system to restart automatically after a lockup, see “Configuring LOMlite2 to Restart the Server Automatically After a Lockup” on page 64.

To remove driver protection from the LOMlite2 driver so that you can unload the driver:

1. **Turn the watchdog process off by typing:**

```
# lom -W off
```

2. **Unload the driver by typing:**

```
# lom -U
```

▼ To Make the LOMlite2 Interface Backward Compatible (`lom -B`)

If you have scripts written to the LOMlite interface on the Netra T1 Model 100/105 server or the Netra t 1400/1405 server and you want to use these scripts on the Netra X1 server, you can add file system links that make this possible. To do so, type:

```
# lom -B
```

When you have done this, you will be able to use the old scripts on the new system.

▼ To Upgrade LOMlite2 Firmware (`lom -G filename`)

To upgrade the firmware for LOMlite2, obtain the new firmware package from the SunSolveSM website (<http://sunsolve.sun.com>), or from your local Sun sales representative, and type the following:

```
# lom -G filename
```

where *filename* is the name of the file containing the new firmware.

Note – LOMlite2 firmware upgrades will be released as patches and will include detailed installation instructions.

PART **III** Troubleshooting and Maintenance

Troubleshooting

This chapter lists some of the problems you might encounter when setting up or using a Netra X1 server, and offers some suggestions on how to fix them. The information is contained in the section:

- “Solutions to Problems You Might Encounter” on page 74

Solutions to Problems You Might Encounter

Cannot Set Up a Console Connection to the Server

The Netra X1 server's serial port pinouts are listed in Chapter 4. Verify that they are correct for the device (that is, the terminal or terminal server) that you are connecting to the Netra X1 server.

Cannot Display the `lom>` Prompt Using the `#.` Escape Sequence

Check whether the first character of the `#.` escape sequence has been changed (this is a user-configurable value). To check the current value, type the following from the Solaris prompt:

```
# lom -c
```

The information that this command displays includes the serial escape character. If this is not `#`, then type the character that is currently specified and follow it immediately with a dot.

Cannot Turn Serial Event Reporting On and Off *Cannot Receive Clearly Formatted LOMlite2 Output* *Cannot Reprogram the LOMlite2 Device*

If you have reinstalled the Solaris 8 (10/00) operating environment on your server and have also reinstalled the LOMlite2 software from the support CD (titled *Software Supplement for the Solaris 8 Operating Environment*), you need to apply the latest version of patch 110208-xx. This patch is available on the SunSolveSM website (<http://sunsolve.sun.com>).

Cannot Display the lom> Prompt or the Solaris Prompt Receiving Corrupted Text at the Console on Serial A/LOM Cannot Access the Server From the Console

First, try resetting the LOMlite2 device. To do this, connect remotely (using the `rlogin hostname` or `telnet hostname` command), and type:

```
# lom -G resetlom
```

If resetting the LOMlite2 device does not fix the problem, reprogram the LOMlite2 device by using the firmware supplied in patch 110208-xx. First apply the patch, and then download the new firmware by typing:

```
# lom -G filename
```

where *filename* is the name of the file containing the new firmware.

OpenBoot PROM Initialization Aborts and the Server Will Not Boot

If the OpenBoot PROM initialization sequence aborts and the message “NO IDPROM” is displayed when the operating system is attempting to read the serial number and MAC address, then you are attempting to boot without a valid system configuration card (SCC) inserted. The SCC contains the serial number, MAC address, and NVRAM settings for the Netra X1 server. For more information about the SCC, see “Replacing an Entire Netra X1 Server” on page 82.

Interpreting the LEDs

This chapter describes the location, function, and meaning of the Netra X1 server's warning LEDs, and contains the following sections:

- “Interpreting the Front- and Back-Panel LEDs” on page 78

Interpreting the Front- and Back-Panel LEDs

The Netra X1 server contains two front panel LEDs (see FIGURE 9-1) and four rear panel LEDs (see FIGURE 9-2). Those on the front panel indicate power and faults only. Those on the back panel indicate the presence of up to two ethernet connections, and replicate the power and fault information of the front LEDs.

Front-Panel LEDs

The front panel LEDs are located at the top left of the server's front bezel.

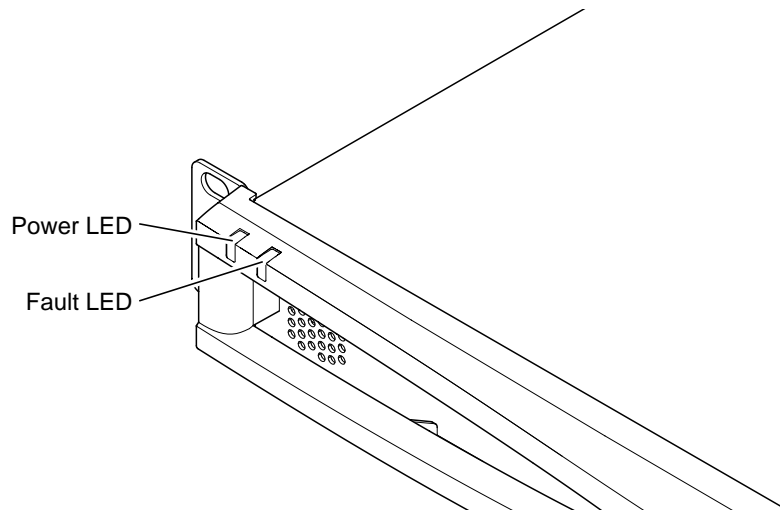

FIGURE 9-1 Front-Panel Power and Fault LEDs

- **Power LED**
This LED is lit when the server is powered on. It is unlit when the server is in standby mode.
- **Fault LED**
The Fault LED is *constantly* on when a problem has occurred that is *not fatal* to the server but that you should attend to as soon as possible. Circumstances that cause this include the following:

- The temperature inside the server's enclosure is unusually high.
- The voltage on one of the server's output supply rails is unusually high.
- One of the server's internal circuit breakers has tripped.
- The system configuration card, containing the server's serial number, MAC address, and NVRAM settings, has been removed.
- The LOMlite2 watchdog has timed out, indicating that the server has locked up. You can configure the server to restart automatically after a lockup (see Chapter 7).

The Fault LED *flashes* when a problem has occurred *that is fatal* to the server. Circumstances that cause the Fault LED to flash include the following:

- The speed of the fan inside the server is too low.
- The temperature inside the server's enclosure is too high. By default, this causes the server to shut down. For information about configuring the server not to shut down in this condition, see Appendix A.
- The voltage on one of the server's output supply rails is too high. By default, this causes the server to shut down. For information about configuring the server not to shut down in this condition, see Appendix A.
- The temperature inside the CPU is too high. This causes the server to shut down.

Back-Panel LEDs

The Netra X1 server contains four back panel LEDs (see FIGURE 9-2):

- **Ethernet port 0**
- **Ethernet port 1**

The light corresponding to each Ethernet port (see FIGURE 9-2) comes on to indicate that a connection has been established to the hub.

- **Fault LED**
This mirrors the Fault LED on the front panel.
- **Power LED**
This mirrors the Power LED on the front panel.

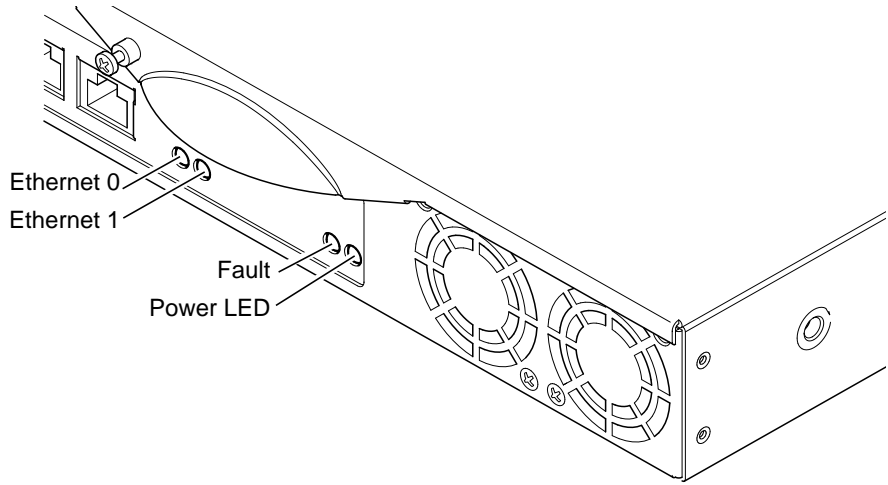

FIGURE 9-2 Back-Panel Power and Fault LEDs

▼ To Turn the Fault LED On or Off

- To turn the Fault LED on, type:

```
# lom -F on
```

- To turn the Fault LED off, type:

```
# lom -F off
```

For more information about the `lom` commands included in the Solaris 8 (10/00) environment, see Chapter 7.

For information about turning the Fault LEDs on and off from the LOMlite2 shell, see Chapter 6.

Removing and Replacing Components

This chapter details the procedures for moving the system configuration card from one server to another, and for changing replaceable components. It contains the following sections:

- “Replacing an Entire Netra X1 Server” on page 82
- “Altering a Netra X1 Server” on page 83

Replacing an Entire Netra X1 Server

The Netra X1 server contains a memory card called the system configuration card. This card contains the system's MAC address, serial number, and other configuration settings. It is designed to be removable so that, if you ever need to replace an entire server, you can transfer the host ID and configuration data onto the new server. This makes the replacement of the server transparent to your network.

▼ To Swap the System Configuration Card (SCC) Between Servers

1. **Make sure that both Netra X1 servers are powered down.**
2. **Remove the zip ties securing the system configuration cards in both servers, and remove the cards.**
3. **Insert the system configuration card from the old server into the new one.**
4. **Replace the zip tie on the new system.**
5. **Power on the new system (see Chapter 5).**



Caution – Never remove the system configuration card when the server is booting or running Solaris. Power the server off or down to standby mode before removing or inserting the system configuration card.



Caution – Do not handle the system configuration card unless you need to transfer it to another system. If you need to handle it for this reason, avoid contact with the gold terminals on the underside of the card.

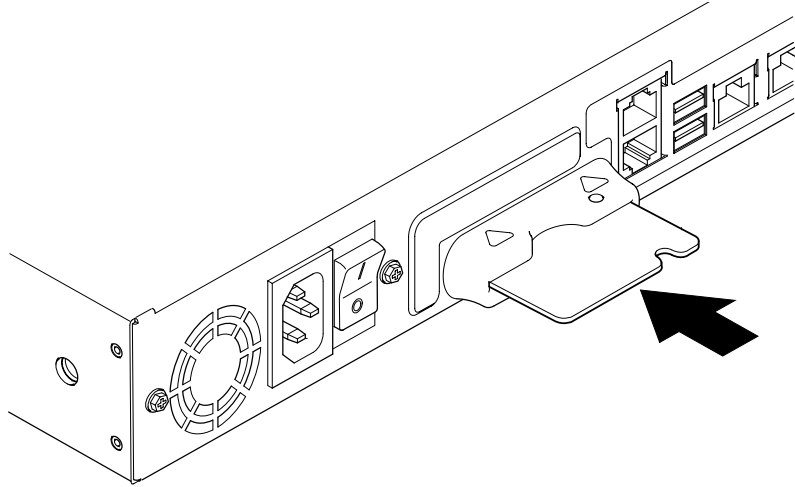

FIGURE 10-1 The System Configuration Card Reader

Altering a Netra X1 Server

The procedures in this section are for the attention of qualified service engineers only. If you must replace or add a component, contact your local Sun sales representative, who will put you in touch with the Sun Enterprise Service branch for your area. You can then arrange to return the system to Sun for repair under the terms of your warranty or you can order the components and have them installed by your own qualified service engineers.



Caution – The system contains electronic parts that are extremely sensitive to static electricity. Do not touch any metal parts. Place the system on top of an electrostatic discharge (ESD) pad (see FIGURE 10-2). Use the disposable antistatic wrist strap supplied with the system, and attach it to the metal base of the system before touching any of the internal components.



Caution – Before attempting to remove the cover, make sure that the server is powered off and that the power cord, and all other cables, have been disconnected from it.

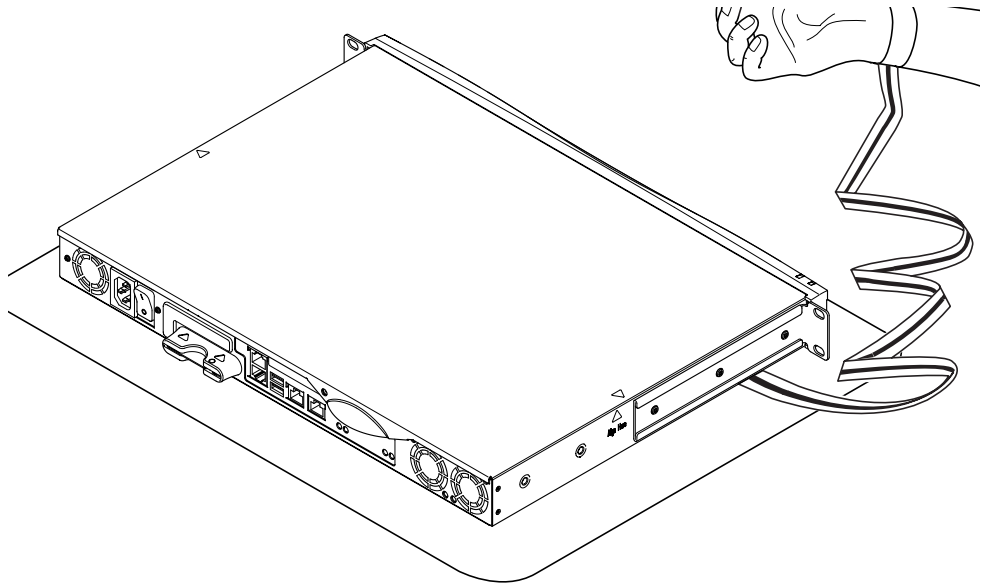

FIGURE 10-2 Using the Disposable Antistatic Wrist Strap Supplied With the System

▼ To Change Components In a Netra X1 Server That Is in Use

If the system is currently in use and you need to open it to install a component:

- 1. Shut down the Solaris environment from the console.**
- 2. Hold the On/Standby switch in the Standby position for more than four seconds to put the server in standby mode.**
- 3. Disconnect the power cord.**
- 4. Disconnect all other cables.**
- 5. If the system is installed in a rack or cabinet, remove it.**

▼ To Remove the Top Cover

- If the Netra X1 server is not in use, go straight to step 1.
- If the server is already in use, see “Changing a Netra X1 Server that is In Use” on page 58.

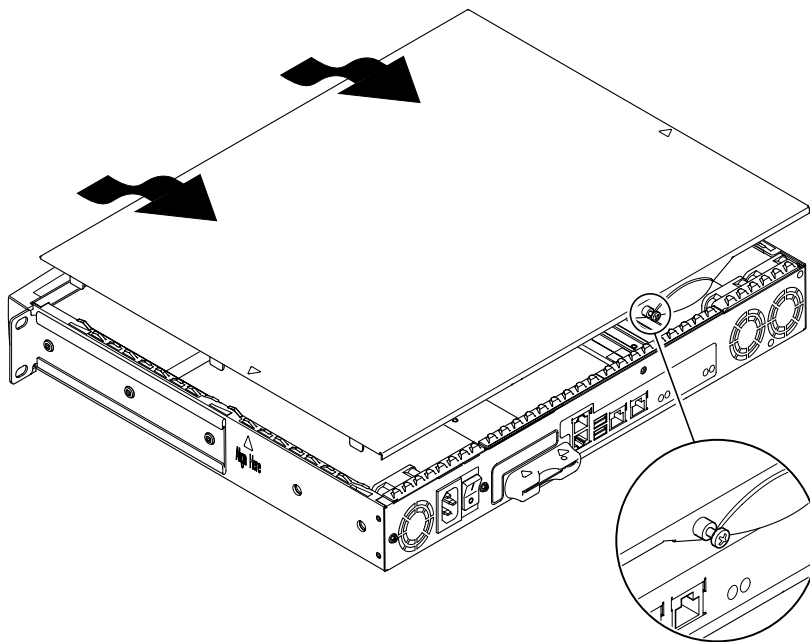

FIGURE 10-3 Removing the Top Cover

1. Place the unit on an ESD surface and attach an antistatic wrist strap (see FIGURE 10-2).
2. Unscrew the captive screw from the back of the unit (see FIGURE 10-3).
3. Slide the top cover back until the arrow on the cover lines up with the arrow on the server body.
4. Lift the cover up and off.

▼ To Replace the Top Cover

1. Align the arrow on the cover with the arrow on the server body.
2. Press the cover down so that it clips into the server body.

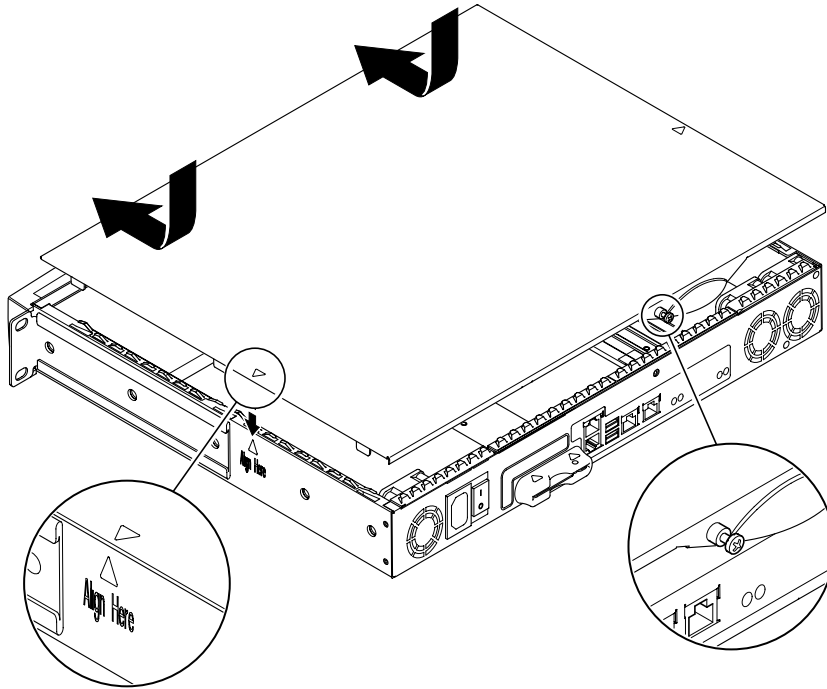

FIGURE 10-4 Replacing the Top Cover

3. Slide the cover forwards so that its leading edge is flush with the back of the server's front bezel.

Note – When the cover is in position, the arrows do not line up; the arrow on the cover is further towards the bezel than the arrow on the server body.

4. Tighten the captive screw on the back of the unit.

Identifying Components

Viewed from the back with the cover removed, the internal components of the Netra X1 server are laid out as in FIGURE 10-5. This image, and a summary of the instructions given in this section, are repeated on the underside of the server's top cover.

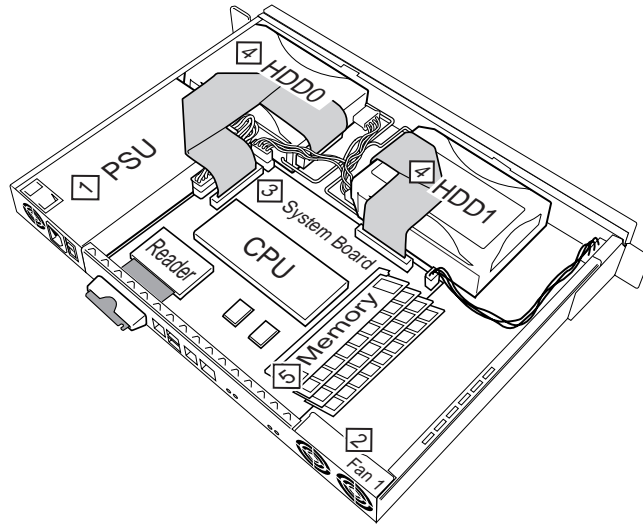

FIGURE 10-5 Layout of Components

The components shown are

1. Power Supply Unit
2. Fan
3. System Board
4. Hard Disk Drive (HDD) 0 and 1
5. Memory

Memory Installation and Removal

There are four industry standard PC133 memory module sockets on the Netra X1 server's system board. You can install standard 128- or 256-Mbyte dual inline memory modules (DIMMs) into each socket. For the maximum 1 Gbyte of memory, install four 256-Mbyte DIMMs.

To see the position of the memory modules inside the server, see FIGURE 10-5 or the underside of the server's top cover.

▼ To Install and Remove Memory

- If the server is not in use, go straight to Step 1.
- If the server is already in use, see “To Change Components In a Netra X1 Server That Is in Use” on page 84.

1. **Place the unit on an ESD surface and attach an antistatic wrist strap (see FIGURE 10-2)**
2. **Remove the server's top cover (see “Removing the Top Cover” on page 58).**
3. **Insert the memory module in the next vacant DIMM socket.**

The memory slots are numbered 3, 2, 1, 0. Add DIMMS in that order.

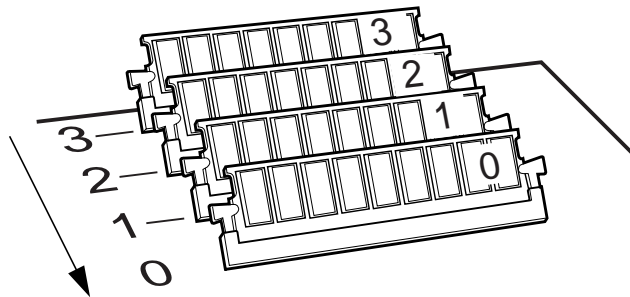

FIGURE 10-6 DIMM Insertion Order

4. **Press the memory module until the latches at the sides of the socket click into place.**

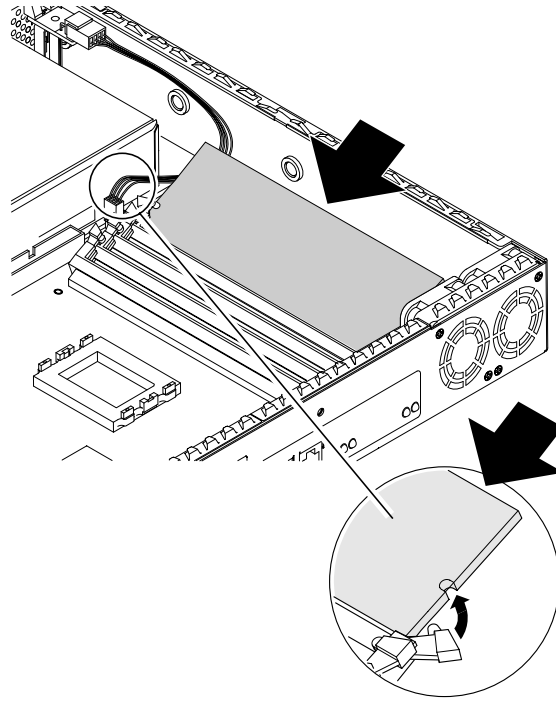

FIGURE 10-7 Installing Memory Into a Socket on the System Board

5. If you are removing memory, open the latches and remove the module(s) in the order 0, 1, 2, 3.
6. Replace the system cover and tighten the captive screw (see FIGURE 10-4).

Hard Disk Drive (HDD) Installation and Removal

The server can accept two HDDs, which are numbered 0 and 1. To see the position of each HDD, see FIGURE 10-5 or the underside of the server's top cover.

▼ To Install a Hard Disk Drive

- If the Netra X1 server is not in use, go straight to Step 1.
- If the server is already in use, see “To Change Components In a Netra X1 Server That Is in Use” on page 84.

1. Place the unit on an ESD surface and attach an antistatic wrist strap (see FIGURE 10-2).
2. Remove the server's top cover (see "To Remove the Top Cover" on page 85).
3. Remove the metal placeholder if your server has one (if it was configured with a single hard disk drive, the second hard disk drive slot will have the placeholder installed).

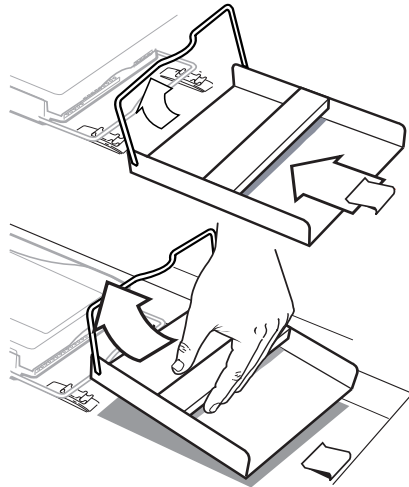

FIGURE 10-8 Removing the HDD Placeholder

4. Insert and align the new hard disk drive (see FIGURE 10-9).
 - a. Position HDD and slide onto the clips on the base of the server.
 - b. Press the handle into the two clips on the base of the server.

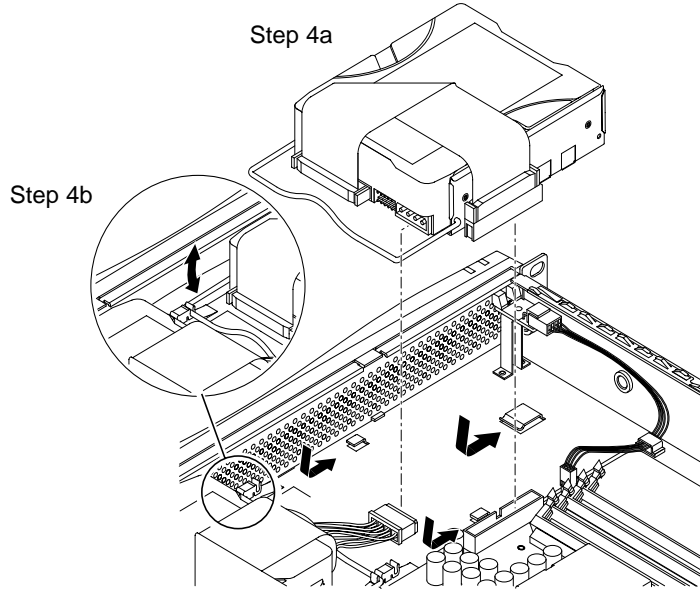

FIGURE 10-9 Installing a Hard Disk Drive

5. Attach the power and data cables.

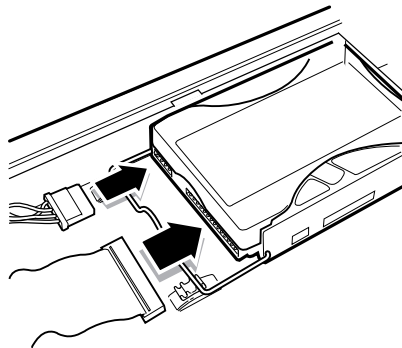

FIGURE 10-10 Attaching the Power and Data Cables

6. Replace the system cover and tighten the captive screw (see FIGURE 10-4).

▼ To Remove a Hard Disk Drive

- If the Netra X1 server is not in use, go straight to Step 1.
 - If the server is already in use, see “Changing a Netra X1 Server that is In Use” on page 58.
1. **Place the unit on an ESD surface and attach an antistatic wrist strap (see FIGURE 10-2).**
 2. **Remove the server’s top cover (see “To Remove the Top Cover” on page 85).**
 3. **Disconnect the data and power cables.**
 4. **Unfasten the hard disk drive’s handle from the two clips securing it.**
 5. **Slide the hard disk drive towards the centre of the server until it is free from the clips on the base of the server.**
 6. **Lift the hard disk drive up and out of the server.**

PART **IV** Appendix

Configuring the Driver for LOMlite2

This appendix describes the parameters that you can use to configure the LOMlite2 driver, and contains the following sections:

- “The LOMlite2 Device Driver and Script Files” on page 96
- “Configuring the LOMlite2 Device Driver” on page 97

The LOMlite2 Device Driver and Script Files

The LOMlite2 driver software included in the Solaris 8 (10/00) operating environment is as follows:

- `/platform/sun4u/kernel/drv/lom` (the lom driver [32-bit])
- `/platform/sun4u/kernel/drv/sparcv9/lom` (the lom driver [64-bit])
- `/platform/sun4u/kernel/drv/lom.conf` (the driver configuration file)

The driver is started by the following three scripts in the Solaris 8 (10/00) environment:

- `/etc/init.d/lom`
- `/etc/rc2.d/S25lom`
- `/etc/rc0.d/K80lom`

This appendix describes the driver parameters you can set in the `lom.conf` configuration file. Some of these parameters are configurable by means of the LOMlite2-specific Solaris commands described in Chapter 7.

Configuring the LOMlite2 Device Driver

The full list of parameters you can set in this file is given in TABLE A-1.

TABLE A-1 LOM Configuration File Parameters

Field	Format	Default	Effect
<code>wdog_reset=</code>	Boolean 0=FALSE 1=TRUE	0	Causes LOMlite2 to reset the server after a watchdog timeout. Setting this to 1 is equivalent to using the <code>lom -R on</code> command described in Chapter 7.
<code>wdog_alarm3=</code>	Boolean 0=FALSE 1=TRUE	0	Turns on software alarm 3 when the LOMlite2 watchdog times out. Setting this to 1 is equivalent to using the <code>lom -A on, 3</code> command described in Chapter 7.
<code>serial_events=</code>	0=OFF 1=ON 2=ON WHEN DRIVER NOT LOADED	2	Causes LOMlite2 to report events over the serial connection. Setting this parameter to 0 means that no events will be reported over the serial connection. Setting it to 1 means that events will be reported over the serial connection as well as to <code>syslogd</code> ; this is equivalent to <code>lom -E on</code> . If you have dedicated the Serial A/LOM port to LOMlite2, you need to set this parameter to 1. It ensures that you receive all event reports at the terminal you have connected to Serial A/LOM. Finally, setting the parameter to 2 means that events will be reported over the serial connection but only when the driver is not running (when it is running they will be reported to <code>syslogd</code> , although Fatal and Warning messages will still go to Serial A/LOM).

TABLE A-1 LOM Configuration File Parameters (*Continued*)

Field	Format	Default	Effect
disable_wdog_on_break=	Boolean 0=FALSE 1=TRUE	1	Causes LOMlite2 to disable its watchdog if it detects a break signal on the Serial A/LOM port.
disable_wdog_on_panic=	Boolean 0=FALSE 1=TRUE	1	Causes LOMlite2 to try to disable its watchdog after a system "panic".
faulty_voltage_shutdown=	Boolean 0=FALSE 1=TRUE	1	Causes LOMlite2 to attempt first to shut down the system and, if that fails, to power off the system in the event of a problem with the supply rails.
enclosure_warning_temp=	°C	67	Specifies the temperature at which LOMlite2 generates an overtemperature event.
over_temperature_shutdown=	Boolean 0=FALSE 1=TRUE	1	Causes LOMlite2 to attempt to shut down the system, or to power it off, if the enclosure temperature exceeds the level specified for the enclosure_shutdown_temp parameter.
enclosure_shutdown_temp=	°C	72	Specifies the enclosure temperature above which LOMlite2 attempts to shut the system down or, if this fails, to power the system off. (LOMlite2 will attempt to do either of these if over_temperature_shutdown is set to 1.)
serial_security=	Boolean 0=FALSE 1=TRUE	1	Enables and disables the user security facilities even if user security has been configured. You can use this parameter to set up users again if your users have forgotten their passwords.

TABLE A-1 LOM Configuration File Parameters (*Continued*)

Field	Format	Default	Effect
<code>serial_timeout=</code>	Multiples of 4 secs	0	Specifies the period after which LOMlite2 gives control of the Serial A/LOM port back to the console when it has finished sending a report (or when the user has issued a LOMlite2 shell command, if you have enabled the <code>serial_return=</code> option). By default, there is no delay at all.
<code>serial_return=</code>	Boolean 0=FALSE 1=TRUE	0	Causes LOMlite2 to return the user to the console from the <code>lom></code> prompt after each LOMlite2 shell command. You can use this option in conjunction with the <code>serial_timeout=</code> option.
<code>reporting_level=</code>	Number between 0 and 4	3	Indicates the severity level down to which you want to see LOMlite2 event reports. 0 means no reports. 1 means fatal event reports only. 2 means fatal and warning event reports. 3 means fatal, warning and information event reports. 4 means fatal, warning, information and user event reports. (User event reports concern the user security facility; you will not see any unless you have enabled the security facility and set up users.)

Each parameter must be on a separate line and must be followed by an equals sign (=) and a value, without spaces. Where the format is Boolean, 1 means true and 0 means false.

Index

A

acoustic noise, 5
alarms, setting, 54, 67
altitude, 4
anti-static wrist strap, 84
Asynchronous Breakout Cable (Cisco), 19
automatic server restart, 61, 64 to 66

B

back panel LEDs, 78
BTU rating, 8

C

cabling, 16
Cisco L2511 Terminal Server, connecting, 18
configuration, 24
cooling (heat dissipation), 9
cross-over (null modem) cable, 20, 21
current
 in-rush, 8
 operating, 8

D

DB25 adapter, 20
DB9 adapter, 21
domain name, 27
dumb terminal, serial connection, 18

E

electro-magnetic compatibility, 5
Ethernet
 connection, 27
 LEDs, 79
 ports, 2
event log, viewing, 43

F

fans, 56
 checking the status, 59
 location, 87
fault LED, 53, 78
 turning on, 55
flooring, 5
front panel LEDs, 78

H

hard disk drive, 2
 installing and removing, 89
 location, 87
 part number, 4
 power and data cables, 91
heat dissipation, 9
host name, 27
 displaying, 55

I

input voltage range, 8

- in-rush current, 8
- installation
 - alternative bracket arrangements, 13
 - mounting brackets, 12
 - rack mounting, 11
- internal circuit breakers, 59

L

LEDs

- back panel, 79
- Ethernet port indicators, 79
- fault indicator, 78
- front panel, 78
- power indicator, 78

Lights Out Management (LOM)

- commands, 54
- displaying the host name, 55
- displaying the version number of the LOM device, 55
- monitoring the system, 58 to 63
- online documentation, 58
- parameters, 97
- power supply unit, 58
- powering up the system, 55
- restarting the system after a lockup, 64
- returning control of serial connection to console, 55
- sample Event Log, 63
- setting the alarms, 54, 67
- setting up named users, 46 to 50
- stopping event reporting, 97
- turning the fault LED on, 55
- updating component status, 54
- viewing the LOM's Event Log, 43

locating system components, 81

log, viewing, 43

LOMlite2 device

- configuration variables, 50
- removing driver protection, 69
- separating from the console on Serial A, 52
- sharing Serial A between the console and the LOMlite2 device, 53
- upgrading firmware, 70
- version number, 55

LOMlite2 interface

- backwards compatibility, 70
- escape sequence, 68

M

memory

- configurations, 2
- installing and removing, 88
- location, 87
- part number, 4

modem connection, 18, 21

- interruption on Serial A port, 18

monitoring the system, *See* Lights-Out Management (LOM)

N

Name Server, 27

Netmask, 28

null modem cable, 20, 21

O

On/Standby switch, 30

operating current, 8

optional components, 4

P

physical specifications, 3

pinout

- serial port, 18, 20

power

- consumption, 9
- factor, 8
- requirements, 8, 9
- switch, 30, 37
- warnings, 17

power LED, 78

power supply

- monitoring PSU and fans, 42

power supply unit, 58

- location, 87

powering on, 30

problems

- accessing the server from the console, 75
- booting (OBP initialization aborts), 75
- displaying the lom> prompt or the Solaris prompt, 75
- getting to the LOM prompt, 74

- receiving clearly formatted LOMlite2 output, 74
- receiving text at the console on Serial A/LOM, 75
- reprogramming the LOMlite2 device, 74
- setting up a console connection, 74
- turning serial event reporting on and off, 74

R

- rackmounting, 12
- remote reset, 39
- removal
 - hard disk drives, 89
 - memory, 88
 - system top cover, 90
- replacing the server, 82
- resetting remotely, 39
- restart after lockup, 64

S

- safety, 5
- SCC (system configuration card), 82
- security, 5
 - LOMlite2 named user accounts, 46 to 50
- Serial A/LOM port, 18
 - data subject to interruption by LOMlite2, 68
- serial A/LOM port, 25, 27, 28
 - dedicating to the LOMlite2 device, 52
 - stopping event reporting to, 68
 - stopping event reports being sent to, 51
- serial connection, 18, 22, 27, 28
 - returning control to console, 55
- serial port, 2
 - connection settings, 22
 - DB25 adapter, 20
 - DB9 adapter, 21
 - pinout, 18, 20
- shipkit, contents, 3
- Solaris 8, 36, 57
- specifications
 - features, 2
- standby power, 8
- stopping event reporting, 68
- supply rail voltages, 59
- system board, location of, 87
- system configuration card (SCC)

- swapping between servers, 82
- system restart, 64

T

- temperature
 - checking the system's temperature, 60
- terminal server, 18
 - serial connection, 18
 - setting up the server using a terminal server, 24
- thermal issues, 5
- tip session, 20
- top cover
 - removing, 85
 - replacing, 86

V

- voltage
 - frequency range, 8
 - input range, 8
- volt-ampere rating, 8

W

- watchdog timeouts, 97
- wrist strap, 84