

AIX Version 6.1



Security

AIX Version 6.1



Security

Note

Before using this information and the product it supports, read the information in "Notices" on page 493.

First Edition (November 2007)

This edition applies to AIX Version 6.1 and to all subsequent releases of this product until otherwise indicated in new editions.

A reader's comment form is provided at the back of this publication. If the form has been removed, address comments to Information Development, Department 04XA-905-6C006, 11501 Burnet Road, Austin, Texas 78758-3493. To send comments electronically, use this commercial Internet address: aix6kpub@austin.ibm.com. Any information that you supply may be used without incurring any obligation to you.

Copyright (c) 1993, 1994 Hewlett-Packard Company
Copyright (c) 1993, 1994 International Business Machines Corp.
Copyright (c) 1993, 1994 Sun Microsystems, Inc.
Copyright (c) 1993, 1994 Novell, Inc.

All rights reserved. This product and related documentation are protected by copyright and distributed under licenses restricting its use, copying, distribution, and decompilation. No part of this product or related documentation may be reproduced in any form by any means without prior written authorization.

RESTRICTED RIGHTS LEGEND: Use, duplication, or disclosure by the United States Government is subject to the restrictions set forth in DFARS 252.227-7013 (c)(1)(ii) and FAR 52.227-19.

THIS PUBLICATION IS PROVIDED "AS IS" WITHOUT WARRANTY OF ANY KIND, EITHER EXPRESS OR IMPLIED, INCLUDING, BUT NOT LIMITED TO, THE IMPLIED WARRANTIES OF MERCHANTABILITY, FITNESS FOR A PARTICULAR PURPOSE, OR NON-INFRINGEMENT.

THIS PUBLICATION COULD INCLUDE TECHNICAL INACCURACIES OR TYPOGRAPHICAL ERRORS. CHANGES ARE PERIODICALLY ADDED TO THE INFORMATION HEREIN; THESE CHANGES WILL BE INCORPORATED IN NEW EDITIONS OF THE PUBLICATION. HEWLETT-PACKARD COMPANY, INTERNATIONAL BUSINESS MACHINES CORP., SUN MICROSYSTEMS, INC., AND UNIX SYSTEMS LABORATORIES, INC., MAY MAKE IMPROVEMENTS AND/OR CHANGES IN THE PRODUCT(S) AND/OR THE PROGRAM(S) DESCRIBED IN THIS PUBLICATION AT ANY TIME.

© Copyright International Business Machines Corporation 2002, 2007. All rights reserved.

US Government Users Restricted Rights – Use, duplication or disclosure restricted by GSA ADP Schedule Contract with IBM Corp.

Contents

About this book	v
Highlighting	v
Case-sensitivity in AIX	v
ISO 9000	v
Related publications	v
Security	1
Securing the Base Operating System	1
Securing the network.	199
AIX Security Expert	337
Security checklist	380
Security resources	381
Summary of common AIX system services.	382
Summary of network service options	393
Trusted AIX	395
Notices	493
Trademarks	494
Index	495

About this book

This topic provides system administrators with complete information on file, system, and network security. This topic contains information about how to perform such tasks as hardening a system, changing permissions, setting up authentication methods, and configuring the Common Criteria Security Evaluation features. This topic is also available on the documentation CD that is shipped with the operating system.

Highlighting

The following highlighting conventions are used in this book:

Bold	Identifies commands, subroutines, keywords, files, structures, directories, and other items whose names are predefined by the system. Also identifies graphical objects such as buttons, labels, and icons that the user selects.
<i>Italics</i>	Identifies parameters whose actual names or values are to be supplied by the user.
Monospace	Identifies examples of specific data values, examples of text similar to what you might see displayed, examples of portions of program code similar to what you might write as a programmer, messages from the system, or information you should actually type.

Case-sensitivity in AIX

Everything in the AIX operating system is case-sensitive, which means that it distinguishes between uppercase and lowercase letters. For example, you can use the **ls** command to list files. If you type **LS**, the system responds that the command is not found. Likewise, **FILEA**, **FiLea**, and **filea** are three distinct file names, even if they reside in the same directory. To avoid causing undesirable actions to be performed, always ensure that you use the correct case.

ISO 9000

ISO 9000 registered quality systems were used in the development and manufacturing of this product.

Related publications

The following publications contain related information:

- *Operating system and device management*
- *Networks and communication management*
- *Installation and migration*
- *AIX Version 6.1 Commands Reference*
- *AIX Version 6.1 Files Reference*
- *AIX Version 6.1 General Programming Concepts: Writing and Debugging Programs*
- *AIX Version 6.1 Network Information Services (NIS and NIS+) Guide*
- *Printers and printing*

Security

AIX® allows you to perform tasks such as hardening a system, changing permissions, setting up authentication methods, and configuring the Common Criteria Security Evaluation features. This topic is also available on the documentation CD that is shipped with the operating system.

To view or download the PDF version of this topic, select Security.

Securing the Base Operating System

Securing the Base Operating System provides information about how to protect the system regardless of network connectivity.

These sections describe how to install your system with security options turned on, and how to secure AIX against nonprivileged users gaining access to the system.

Secure system installation and configuration

Several factors are involved in the secure installation and configuration of AIX.

Trusted Computing Base

The system administrator must determine how much trust can be given to a particular program. This determination includes considering the value of the information resources on the system in deciding how much trust is required for a program to be installed with privilege.

The Trusted Computing Base (TCB) is the part of the system that is responsible for enforcing system-wide information security policies. By installing and using the TCB, you can define user access to the trusted communication path, which permits secure communication between users and the TCB. TCB features can only be enabled when the operating system is installed. To install TCB on an already installed machine, you will have to perform a Preservation installation. Enabling TCB permits you to access the trusted shell, trusted processes, and the Secure Attention Key (SAK).

Installing a system with the TCB:

The TCB is the part of the system that is responsible for enforcing the information security policies of the system. All of the computer's hardware is included in the TCB, but a person administering the system should be concerned primarily with the software components of the TCB.

If you install a system with the Trusted Computing Base option, you enable the trusted path, trusted shell, and system-integrity checking (**tcbck** command). These features can *only* be enabled during a base operating system (BOS) installation. If the TCB option is not selected during the initial installation, the **tcbck** command is disabled. You can use this command only by reinstalling the system with the TCB option enabled.

To set the TCB option during a BOS installation, select **More Options** from the Installation and Settings screen. In the Installation Options screen, the default for the **Install Trusted Computing Base** selection is **no**. To enable the TCB, type 2 and press Enter.

Because every device is part of the TCB, every file in the **/dev** directory is monitored by the TCB. In addition, the TCB automatically monitors over 600 additional files, storing critical information about these files in the **/etc/security/sysck.cfg** file. If you are installing the TCB, immediately after installing, back up this file to removable media, such as tape, CD, or disk, and store the media in a secure place.

Checking the TCB:

The security of the operating system is jeopardized when the Trusted Computing Base (TCB) files are not correctly protected or when configuration files have unsafe values.

The **tcbck** command audits the security state of the Trusted Computing Base. The **tcbck** command audits this information by reading the **/etc/security/sysck.cfg** file. This file includes a description of all TCB files, configuration files, and trusted commands.

The **/etc/security/sysck.cfg** file is not offline and, could therefore be altered by a hacker. Make sure you create an offline read-only copy after each TCB update. Also, copy this file from the archival media to disk before doing any checks.

Installing the TCB and using the **tcbck** command do not guarantee that a system is operating in a Controlled Access Protection Profile (CAPP) and Evaluation Assurance Level 4+ (EAL4+) compliant mode. For information on the CAPP/EAL4+ option, see “Controlled Access Protection Profile and Evaluation Assurance Level 4+ and Labeled Security Protection Profile and Evaluation Assurance Level 4+” on page 12.

Structure of the *sysck.cfg* file:

The **tcbck** command reads the **/etc/security/sysck.cfg** file to determine which files to check. Each trusted program on the system is described by a stanza in the **/etc/security/sysck.cfg** file.

Each stanza has the following attributes:

acl	Text string representing the access control list for the file. It must be of the same format as the output of the aclget command. If this does not match the actual file ACL (access control list), the sysck command applies this value using the aclput command. Note: The SUID, SGID, and SVTX attributes must match those specified for the mode, if present.
class	Name of a group of files. This attribute permits several files with the same class name to be checked by specifying a single argument to the tcbck command. More than one class can be specified, with each class being separated by a comma.
group	Group ID or name of the file group. If this does not match the file group, the tcbck command sets the group ID of the file to this value.
links	Comma-separated list of path names linked to this file. If any path name in this list is not linked to the file, the tcbck command creates the link. If used without the <i>tree</i> parameter, the tcbck command prints a message that there are extra links but does not determine their names. If used with the <i>tree</i> parameter, the tcbck command also prints any additional path names linked to this file.
mode	Comma-separated list of values. The permissible values are SUID, SGID, SVTX, and TCB. The file permissions must be the last value and can be specified either as an octal value or as a 9-character string. For example, either 755 or <i>rwrx-xr-x</i> are valid file permissions. If this does not match the actual file mode, the tcbck command applies the correct value.
owner	User ID or name of the file owner. If this does not match the file owner, the tcbck command sets the owner ID of the file to this value.
program	Comma-separated list of values. The first value is the path name of a checking program. Additional values are passed as arguments to the program when the program is run. Note: The first argument is always one of <i>-y</i> , <i>-n</i> , <i>-p</i> , or <i>-t</i> , depending on which flag the tcbck command was used with.
source	Name of a file this source file is to be copied from prior to checking. If the value is blank, and this is either a regular file, directory, or a named pipe, a new empty version of this file is created if it does not already exist. For device files, a new special file is created for the same type device.

symlinks

Comma-separated list of path names symbolically linked to this file. If any path name in this list is not a symbolic link to the file, the **tcbck** command creates the symbolic link. If used with the *tree* argument, the **tcbck** command also prints any additional path names that are symbolic links to this file.

If a stanza in the **/etc/security/sysck.cfg** file does not specify an attribute, the corresponding check is not performed.

Using the tcbck command:

The **tcbck** command is used to ensure the proper installation of security-relevant file; to ensure the file system tree contains no files that clearly violate system security; and to update, add, or delete trusted files.

The **tcbck** command is normally used for the following tasks:

- Ensure the proper installation of security-relevant files
- Ensure that the file system tree contains no files that clearly violate system security
- Update, add, or delete trusted files

The **tcbck** command can be used in the following ways:

- Normal use
 - Noninteractive at system initialization
 - With the **cron** command
- Interactive use
 - Check out individual files and classes of files
- Paranoid use
 - Store the **sysck.cfg** file offline and restore it periodically to check out the machine

Although not cryptographically secure, the TCB uses the **sum** command for checksums. The TCB database can be set up manually with a different checksum command, for example, the **md5sum** command that is shipped in the textutils RPM Package Manager package with *AIX Toolbox for Linux Applications CD*.

Checking trusted files:

Use the **tcbck** command to check and fix all the files in the tcbck database, and fix and produce a log of all errors.

To check all the files in the tcbck database, and fix and report all errors, type:

```
tcbck -y ALL
```

This causes the **tcbck** command to check the installation of each file in the tcbck database described by the **/etc/security/sysck.cfg** file.

To perform this automatically during system initialization, and produce a log of what was in error, add the previous command string to the **/etc/rc** command.

Checking the file system tree:

Whenever you suspect the integrity of the system might have been compromised, run the **tcbck** command to check the file system tree.

To check the file system tree, type:

```
tcbck -t tree
```

When the **tcbck** command is used with the *tree* value, all files on the system are checked for correct installation (this could take a long time). If the **tcbck** command discovers any files that are potential threats to system security, you can alter the suspected file to remove the offending attributes. In addition, the following checks are performed on all other files in the file system:

- If the file owner is root and the file has the SetUID bit set, the SetUID bit is cleared.
- If the file group is an administrative group, the file is executable, and the file has the SetGID bit set, the SetGID bit is cleared.
- If the file has the **tcb** attribute set, this attribute is cleared.
- If the file is a device (character or block special file), it is removed.
- If the file is an additional link to a path name described in **/etc/security/sysck.cfg** file, the link is removed.
- If the file is an additional symbolic link to a path name described in **/etc/security/sysck.cfg** file, the symbolic link is removed.

Note: All device entries must have been added to the **/etc/security/sysck.cfg** file prior to execution of the **tcbck** command or the system is rendered unusable. To add trusted devices to the **/etc/security/sysck.cfg** file, use the **-I** flag.

Attention: *Do not* run the **tcbck -y tree** command option. This option deletes and disables devices that are not properly listed in the TCB, and might disable your system.

Adding a trusted program:

Use the **tcbck** command to add a specific program to the **/etc/security/sysck.cfg** file.

To add a specific program to the **/etc/security/sysck.cfg** file, type:

```
tcbck -a PathName [Attribute=Value]
```

Only attributes whose values are not deduced from the current state of the file need be specified on the command line. All attribute names are contained in the **/etc/security/sysck.cfg** file.

For example, the following command registers a new SetUID root program named **/usr/bin/setgroups**, which has a link named **/usr/bin/getgroups**:

```
tcbck -a /usr/bin/setgroups links=/usr/bin/getgroups
```

To add **jfh** and **jsl** as administrative users and to add **developers** as an administrative group to be verified during a security audit of the **/usr/bin/abc** file, type:

```
tcbck -a /usr/bin/abc setuids=jfh,jsl setgids=developers
```

After installing a program, you might not know which new files are registered in the **/etc/security/sysck.cfg** file. These files can be found and added with the following command:

```
tcbck -t tree
```

This command string displays the name of any file that is to be registered in the **/etc/security/sysck.cfg** file.

Deleting a trusted program:

If you remove a file from the system that is described in the **/etc/security/sysck.cfg** file, you must also remove the description of this file from the **/etc/security/sysck.cfg** file.

For example, if you have deleted the **/etc/cvid** program, the following command string produces an error message:

```
tcbck -t ALL
```

The resulting error message is as follows:

```
3001-020 The file /etc/cvid was not found.
```

The description for this program remains in the **/etc/security/sysck.cfg** file. To remove the description of this program, type the following command:

```
tcbck -d /etc/cvid
```

Configuring additional trusted options:

You can configure additional options for the Trusted Computing Base (TCB).

Restricting access to a terminal:

You can configure the operating system to restrict terminal access.

The **getty** and **shell** commands change the owner and mode of a terminal to prevent untrusted programs from accessing the terminal. The operating system provides a way to configure exclusive terminal access.

Using the Secure Attention Key:

A trusted communication path is established by pressing the Secure Attention Key (SAK) reserved key sequence (Ctrl-X, and then Ctrl-R).

Note: Use caution when using SAK because it stops all processes that attempt to access the terminal and any links to it (for example, **/dev/console** can be linked to **/dev/tty0**).

A trusted communication path is established under the following conditions:

- When logging in to the system
After you press the SAK:
 - If a new login screen displays, you have a secure path.
 - If the trusted shell prompt displays, the initial login screen was an unauthorized program that might have been trying to steal your password. Determine who is currently using this terminal by using the **who** command and then log off.
- When you want the command you enter to result in a trusted program running. Some examples of this include:
 - Running as root user. Run as root user only after establishing a trusted communication path. This ensures that no untrusted programs are run with root-user authority.
 - Running the **su**, **passwd**, and **newgrp** commands. Run these commands only after establishing a trusted communication path.

Configuring the Secure Attention Key:

Configure the Secure Attention Key to create a trusted communication path.

Each terminal can be independently configured so that pressing the Secure Attention Key (SAK) at that terminal creates a trusted communication path. This is specified by the **sak_enabled** attribute in **/etc/security/login.cfg** file. If the value of this attribute is True, the SAK is enabled.

If a port is to be used for communications, (for example, by the **uucp** command), the specific port used has the following line in its stanza of the **/etc/security/login.cfg** file:

```
sak_enabled = false
```

This line (or no entry in that stanza) disables the SAK for that terminal.

To enable the SAK on a terminal, add the following line to the stanza for that terminal:

```
sak_enabled = true
```

Trusted Execution

Trusted Execution (TE) refers to a collection of features that are used to verify the integrity of the system and implement advance security policies, which together can be used to enhance the trust level of the complete system.

The usual way for a malicious user to harm the system is to get access to the system and then install Trojans, rootkits or tamper some security critical files, resulting in the system becoming vulnerable and exploitable. The central idea behind the set of features under Trusted Execution is prevention of such activities or in worst case be able to identify if any such incident happens to the system. Using the functionality provided by Trusted Execution, the system administrator can decide upon the actual set of executables that are allowed to execute or the set of kernel extensions that are allowed to be loaded. It can also be used to audit the security state of the system and identify files that have changed, thereby increasing the trusted level of the system and making it more difficult for the malicious user to do harm to the system. The set of features under TE can be grouped into the following:

- Managing Trusted Signature Database
- Auditing integrity of the Trusted Signature Database
- Configuring Security Policies
- Trusted Execution Path and Trusted Library Path

Note: A TCB functionality already exists in AIX. TE is a more powerful and enhanced mechanism that overlaps some of the TCB functionality and provides advance security policies to better control the integrity of the system. While the Trusted Computing Base is still available, Trusted Execution introduces a new and more advanced concept of verifying and guarding the system integrity.

Trusted Signature Database Management:

Similar to that of Trusted Computing Base (TCB) there exists a database which is used to store critical security parameters of trusted files present on the system. This database, called Trusted Signature Database (TSD), resides in the ***/etc/security/tsd/tsd.dat***.

A *trusted file* is a file that is critical from the security perspective of the system, and if compromised, can jeopardize the security of the entire system. Typically the files that match this description are the following:

- Kernel (operating system)
- All `setuid` root programs
- All `setgid` root programs
- Any program that is exclusively run by the root user or by a member of the system group
- Any program that must be run by the administrator while on the trusted communication path (for example, the **`ls`** command)
- The configuration files that control system operation
- Any program that is run with the privilege or access rights to alter the kernel or the system configuration files

Every trusted file should ideally have an associated stanza or a file definition stored in the Trusted Signature Database (TSD). A file can be marked as trusted by adding its definition in the TSD using the **`trustchk`** command. The **`trustchk`** command can be used to add, delete, or list entries from the TSD.

Trusted Signature Database:

The Trusted Signature Database is a database that is used to store critical security parameters of trusted files present on the system. This database resides in the ***/etc/security/tsd/tsd.dat*** directory.

Every trusted file should ideally have an associated stanza or a file definition stored in the Trusted Signature Database (TSD). Every trusted file is associated with a unique cryptographic hash and a digital signature. The cryptographic hash of the default set of trusted files is generated using the SHA-256 algorithm and the digital signature is generated using RSA by the AIX build environment and packaged as part of AIX installation filesets. These hash values and the signatures are shipped as part of respective AIX installation images and stored in the Trusted Software Database (**/etc/security/tsd/tsd.dat**) on the destination machine, in the sample stanza format that follows:

```

/usr/bin/ps:
    owner          = bin
    group          = system
    mode           = 555
    type           = FILE
    hardlinks      = /usr/sbin/ps
    symlinks       =
    size           = 1024
    cert_tag       = bbe21b795c550ab243
    signature      =
f7167eb9ba3b63478793c635fc991c7e9663365b2c238411d24c2a8a
    hash_value     = c550ab2436792256b4846a8d0dc448fc45
    minslabel      = SLSL
    maxslabel      = SLSL
    intlabel       = SHTL
    accessauths    = aix.mls.pdir, aix.mls.config
    innateprivs    = PV_LEF
    proxyprivs     = PV_DAC
    authprivs      =
aix.security.cmds:PV_DAC,aix.ras.audit:PV_AU_ADMIN
    secflags       = FSF_EPS
    t_accessauths =
    t_innateprivs =
    t_proxyprivs  =
    t_authprivs   =
    t_secflags    =

```

owner Owner of the file. This value is computed by the **trustchk** command when the file is being added to TSD.

group Group of the file. This value is computed by the **trustchk** command.

mode Comma separated list of values. The permissible values are **SUID** (SUID set bit), **SGID** (SGID set bit), **SVTX** (SVTX set bit), and **TCB** (Trusted Computing Base). The file permissions must be the last value and can be specified as an octal value. For example, for a file that is set uid and has permission bits as rwxr-xr-x, the value for mode is **SUID,755**. The value is computed by the **trustchk** command.

type Type of the file. This value is computed by the **trustchk** command. The possible values are **FILE**, **DIRECTORY**, **MPX_DEV**, **CHAR_DEV**, **BLK_DEV**, and **FIFO**.

hardlinks

List of hardlinks to the file. This value cannot be computed by the **trustchk** command. It must be supplied by the user when adding a file to the database.

symlinks

List of symbolic links to the file. This value cannot be computed by the **trustchk** command. It must be supplied by the user when adding a file to the database.

size Defines size of the file. The **VOLATILE** value means the file gets changed frequently.

cert_tag

This field maps the digital signature of the file with the associated certificate that can be used to verify the file's signatures. This field stores the certificate id and is computed by the **trustchk** command at the time of addition of the file to the TSD. The certificates are stored in **/etc/security/certificates** directory.

signature

Digital signature of the file. The **VOLATILE** value means the file gets changed frequently. This field is computed by the **trustchk** command.

hash_value

Cryptographic hash of the file. The **VOLATILE** value means the file gets changed frequently. This field is computed by the **trustchk** command.

minlabel

Defines the minimum sensitivity label for the object.

maxlabel

Defines the maximum sensitivity label for the object (valid on Trusted AIX system). This attribute is not applicable to regular files and fifo.

intlabel

Defines the integrity label for the object (valid on Trusted AIX system).

accessauths

Defines the access authorization on the object (valid on Trusted AIX system).

innateprivs

Defines the innate privileges for the file.

proxyprivs

Defines the proxy privileges for the file.

authprivs

Defines the privileges that are assigned to the user after given authorizations.

secflags

Defines the file security flags associated with the object.

t_accessauth

Defines the additional Trusted AIX with Multi-Level Security (MLS) specific access authorizations (valid on Trusted AIX system).

t_innateprivs

Defines the additional Trusted AIX with MLS specific innate privileges for the file (valid on Trusted AIX system).

t_proxyprivs

Defines the additional Trusted AIX with MLS specific proxy privileges for the file (valid on Trusted AIX system).

t_authprivs

Defines the additional Trusted AIX with MLS specific privileges that are assigned to the user after given authorizations (valid on Trusted AIX system).

t_secflags

Defines the additional Trusted AIX with MLS specific file security flags associated with the object (valid on Trusted AIX system).

While adding a new entry to TSD, if a trusted file has some symbolic or hard links pointing to it, then these links can be added to the TSD by using **symlinks** and **hardlinks** attributes at the command line, along with the **trustchk** command. If the file being added is expected to change frequently, then use **VOLATILE** keyword at the command line. Then the **trustchk** command would not calculate the **hash_value** and **signature** fields when it generates the file definition for addition into the TSD. During integrity verification of this file, the **hash_value** and **signature** fields are ignored.

During addition of regular file definitions to the TSD, it is necessary to provide a private key (ASN.1/DER format). Use the **-s** flag and digital certificate with the corresponding public key using the **-v** flag. The private key is used to generate the signature of the file and then discarded. It is up to the user to store this

key securely. The certificate is stored into a certificate store in the `/etc/security/certificates` file for the signatures to be verified whenever you request integrity verification. Since signature calculation is not possible for non-regular files like directory and device files, it is not mandatory to supply the private key and certificate while adding such files to TSD.

You can also supply the pre-computed file definition through a file using the `-f` option to be added to the TSD. In this case the `trustchk` does not compute any of the values and stores the definitions into TSD without any verification. The user is responsible for sanity of the file definitions in this case.

Auditing the integrity of Trusted Signature Database:

The `trustchk` command can be used to audit the integrity state of the file definitions in the Trusted Signature Database (TSD) against the actual files.

If the `trustchk` command identifies an anomaly, then it can be made to automatically correct it or prompt the user before attempting correction. If anomalies like size, signature, `cert_tag` or `hash_value` mismatch, the correction is not possible. In such cases, the `trustchk` command would make the file inaccessible, thereby rendering it useless and containing any damage.

Following corrective actions shall be taken for different mismatching attributes:

owner Owner of the file shall be reset to the value in TSD.

group Group of the file shall be reset to the value in TSD.

mode Mode bits of the file be reset to the value in TSD.

hardlinks

If the link points to some other file, it is modified to point to this file. If the link does not exist, a new link is created to point to this file.

symlinks

Same as hardlinks.

type File is made inaccessible.

size File is made inaccessible, except in case of **VOLATILE** file.

cert_tag

File is made inaccessible.

signature

File is made inaccessible, except in case of **VOLATILE** file.

hash_value

File is made inaccessible, except in case of **VOLATILE** file.

minslabel

On a Trusted AIX system, the minimum sensitivity label is reset to the value in the TSD.

maxslabel

On a Trusted AIX system, the maximum sensitivity label is reset to the value in the TSD.

intlabe

On a Trusted AIX system, the integrity label is reset to the value in the TSD.

accessauths

The access authorizations are reset to the value in TSD. On Trusted AIX, the `t_accessauths` values are considered part of the `accessauths` attribute.

innateprivs

The innate privileges are reset to the value in TSD. On Trusted AIX, the `t_innateprivs` values are considered part of the `innateprivs` attribute.

inheritprivs

The inheritable privileges are reset to the value in TSD. On Trusted AIX, the **t_inheritprivs** values are considered part of the inherit attribute.

authprivs

The authorized privileges are reset to the value in TSD. On Trusted AIX, the **t_authprivs** values are considered part of the **authprivs** attribute.

aecflags

The security flags are reset to the value in TSD. On Trusted AIX, the **t_secglags** values are considered as part of the **secflags** attribute.

You can also validate file definitions against an alternate database using the **-F** option. The system administrator should avoid storing the TSD on the same system and backup the database to some alternate location. This file integrity can be made to match against this backed up version of TSD using the **-F** option.

Security policies configuration:

The Trusted Execution (TE) feature provides you with a run-time file integrity verification mechanism. Using this mechanism, the system can be configured to check the integrity of the trusted files before every request to access those file, effectively allowing only the trusted files that pass the integrity check to be accessed on the system.

When a file is marked as trusted (by adding its definition to Trusted Signature Database), the TE feature can be made to monitor its integrity on every access. TE can continuously monitor the system and is capable of detecting tampering of any trusted file (by a malicious user or application) present on the system at run-time (for example, at load time). If the file is found to be tampered, TE can take corrective actions based on pre-configured policies, such as disallow execution, access to the file, or logging error. If a file being opened or executed, and has an entry in the Trusted Signature Database (TSD), the TE performs as follows:

- Before loading the binary, the component responsible for loading the file (system loader) invokes the Trusted Execution subsystem, and calculates the hash value using the SHA-256 algorithm (configurable).
- This run-time calculated hash value is matched with the one stored in the TSD.
- If the values match, the file opening or execution is permitted.
- If the values do not match, either the binary is tampered, or somehow compromised. It is up to the user to decide the action to be taken. The TE mechanism provides options for users to configure their own policies for the actions to be taken if the hash values do not match.
- Based on these configured policies, a relevant action is taken.

The following policies can be configured:

CHKEXEC

Check hash value of only the trusted executables before loading them in memory for execution.

CHKSHLIBS

Check the hash value of only the trusted shared libraries before loading them in memory for execution.

CHKSCRIPTS

Check the hash value of only the trusted shell scripts before loading them in memory.

CHKKERNEXT

Check the hash value of only the kernel extension before loading it in memory.

STOP_UNTRUSTD

Stop loading of files that are not trusted. Only files belonging to TSD are loaded. This policy only

works in combination with any of the CHK* policies mentioned above. For example, if **CHKEXEC=ON** and **STOP_UNTRUSTD=ON**, then any executable binary that does not belong to TSD is blocked from execution.

STOP_ON_CHKFAIL

Stop loading of trusted files that fail hash value check. This policy also works in combination with CHK* policies. For example, if **CHKSHLIBS=ON** and **STOP_ON_CHKFAIL=ON**, then any shared library not belonging to the TSD is blocked from being loaded into memory for use.

TSD_LOCK

Lock TSD so it is not available for editing.

TSD_FILES_LOCK

Lock trusted files. This does not allow opening of trusted files in write mode.

TE Enable/Disable Trusted Execution functionality. Only when this is enabled, the above mentioned policies are in effect.

The following table gives the interaction between different CHK* policies and STOP* policies when enabled:

Policy	STOP_UNTRUSTD	STOP_ON_CHKFAIL
CHKEXEC	Stop loading of executables that do not belong to TSD.	Stop loading of executables whose hash values do not match the TSD values.
CHKSHLIBS	Stop loading of shared libraries that do not belong to TSD.	Stop loading of shared libraries whose hash values do not match the TSD values.
CHKSCRIPTS	Stop loading of shell scripts that do not belong to TSD.	Stop loading of shell scripts whose hash values do not match the TSD values.
CHKKERNEXT	Stop loading of kernel extensions that do not belong to TSD.	Stop loading of kernel extensions whose hash values do not match the TSD values.

Note: A policy can be enabled or disabled at any time until the TE is turned on to bring the policies into effect. Once a policy is in effect, disabling that policy becomes effective only on next boot cycle. All the information messages are logged into **syslog**.

Trusted Execution Path and Trusted Library Path:

Trusted Execution Path (TEP) defines a list of directories that contain the trusted executables. Once TEP verification is enabled, the system loader allows only binaries in the specified paths to execute. Trusted Library Path (TLP) has the same functionality, except that it is used to define the directories that contain trusted libraries of the system.

Once TLP is enabled, the system loader allows only the libraries from this path to be linked to the binaries. The **trustchk** command can be used to enable or disable the TEP or TLP, as well as set the colon separated path list for both, using TEP and TLP command line attributes of the **trustchk** command.

Trusted Shell and Secure Attention Key:

Trusted Shell and Secure Attention Key (SAK) perform similarly to the Trusted Computing Base (TCB), except that if Trusted Execution is enabled on the system instead of TCB, the Trusted Shell executes files belonging only to the Trusted Signature Database.

For more information about TCB and SAK, see Trusted Computing Base, Using the Secure Attention Key, and Configuring the Secure Attention Key.

Controlled Access Protection Profile and Evaluation Assurance Level 4+ and Labeled Security Protection Profile and Evaluation Assurance Level 4+

System administrators can install a system with the Controlled Access Protection Profile (CAPP) and Evaluation Assurance Level 4+ (EAL4+) option or Labeled Security Protection Profile (LSPP) and Evaluation Assurance Level 4+ (EAL4+) during a base operating system (BOS) installation. A system with these options has restrictions on the software that is installed during BOS installation, plus network access is restricted.

Note: Evaluations are currently ongoing for AIX Version 6.1. Please refer to the AIX Version 6.1 release notes for the latest information.

CAPP/EAL4+ compliant system overview:

A CAPP system is a system that has been designed and configured to meet the Controlled Access Protection Profile (CAPP) for security evaluation according to the Common Criteria. The CAPP specifies the functional requirements for the system, similar to the earlier TCSEC C2 standard (also known as the *Orange Book*).

A Common Criteria (CC) Evaluated System is a system that has been evaluated according to the Common Criteria, an ISO standard (ISO 15408) for the assurance evaluation of IT products. The system configuration that meets these requirements is referred to as a *CAPP/EAL4+ system* in this guide.

If a system is evaluated according to the CC, the CC evaluation is valid only for a specific system configuration (hardware and software). Changing the relevant security configuration results in a nonevaluated system. This does not necessarily mean that the security of the system will be reduced, but only indicates that the system is no longer in a certified configuration. Neither the CAPP nor the CC cover all possible security configuration options of AIX 6.1. Some features, such as IPsec or custom-password checking modules, are not included, but can be used to enhance the security of the system.

The AIX 6.1 CAPP/EAL4+ system includes the base operating system on 64-bit POWER5™, POWER5™, and POWER6™ processors with the following:

- Logical Volume Manager (LVM) and the enhanced journaled file system (JFS2)
- The X-Windows system with the CDE interface
- Basic Internet Protocol version 4 (IPv4) network functions (Telnet, FTP, rlogin, rsh/rcp)
- Network File System (NFS)

A CAPP/EAL4+ system is considered to be in a secured state if the following conditions apply:

- If auditing is configured and the system is in multi-user mode, then auditing must be operational.
- The system accepts user logins and services network requests.
- For a distributed system, the administrative databases are NFS-mounted from the master server.

The following administrative interfaces to the security functionality are provided:

- Identification and authentication measures (configuration of users, password settings, login configuration, and so on.)
- Audit measures (configuring bin mode audition, selecting audited events, processing audit trails, and so on.)
- Discretionary access control (permission bits and ACLs for file system objects, IPC mechanisms and TCP ports)
- Setting the system time
- Running the diag diagnostic subsystem
- Running the **su** command to become a privileged administrator (root)

This includes the configuration files and system calls that can be used to perform the appropriate administration.

The following user interfaces to the security functionality are provided:

- The **passwd** command for changing a user's password
- The **su** command for changing a user's identity
- The **at**, **batch**, and **crontab** facilities for the scheduling of command processing
- Discretionary access control (permission bits and ACLs for file system objects and IPC mechanisms)
- Login mechanisms (for example, identification and authentication mechanisms) for the system console and the supported network applications (such as, telnet and ftp)

This includes the system calls dealing with the settings of user identity or access control.

The AIX 6.1 CAPP/EAL4+ system runs on hardware platforms based on IBM® eServer™ pSeries® Symmetric Multiprocessor (SMP) systems using POWER5, POWER5+™, and POWER6™ processors. Peripheral devices that are supported are terminals and printers, hard disks and CD-ROM drives as storage devices, and streamers and diskette drives as backup devices. Supported network connector types are Ethernet and token ring.

The CAPP/EAL4+ technology runs on POWER5, POWER5+, and POWER6 processor hardware platforms that support logical partition configuration. Peripheral devices that are supported are terminals and printers, hard disks and CD-ROM drives as storage devices, and streamers and diskette drives as backup devices. Supported network connector types are Ethernet and token ring. Common Criteria mode only supports SCSI optical devices.

Note: Administrators must inform all users of the system not to use the **\$HOME/.rhosts** file for remote login and running commands.

Installing a CAPP/EAL4+ system:

RBAC is automatically enabled when this option is selected.

To set the CAPP/EAL4+ option during a BOS installation, do the following:

1. In the Installation and Settings screen, select **More Options**.
2. In the More Options screen, type the number corresponding to the Yes or No choice for **Enable CAPP and EAL4+ Technology**. The default is set to No.

The **Enable CAPP and EAL4+ Technology** option is available only under the following conditions:

- The installation method is set to new and complete overwrite installation.
- The English language is selected.
- The 64-bit kernel is enabled.
- The enhanced journaled file system (JFS2) is enabled.

When the **Enable CAPP and EAL4+ Technology** option is set to Yes, the **Trusted Computing Base** option is also set to Yes, and the only valid **Desktop** choices are NONE or CDE.

If you are performing a nonprompted installation using a customized **bosinst.data** file, the **INSTALL_TYPE** field must be set to **CC_EVAL** and the following fields must be set as follows:

```
control_flow:  
CONSOLE = ???  
PROMPT = yes  
INSTALL_TYPE = CC_EVAL  
INSTALL_METHOD = overwrite  
TCB = yes  
DESKTOP = NONE or CDE
```

```
ENABLE_64BIT_KERNEL = yes
CREATE_JFS2_FS = yes
ALL_DEVICES_KERNELS = no
FIREFOX_BUNDLE = no
HTTP_SERVER_BUNDLE = no
KERBEROS_5_BUNDLE = no
SERVER_BUNDLE = no
ALT_DISK_INSTALL_BUNDLE = no
```

locale:

```
CULTURAL_CONVENTION = en_US or C
MESSAGES = en_US or C
```

For more information about RBAC, see Role Based Access Control (RBAC).

CAPP/EAL4+ and the Network Installation Management environment:

Installation of CAPP/EAL4+ technology clients can be performed using the Network Installation Management (NIM) environment.

The NIM master is configured to provide the resources needed to install the appropriate CAPP/EAL4+ level of AIX 6.1. NIM clients may then be installed using the resources located on the NIM master. You can perform a nonprompted NIM installation of the client by setting the following fields in the bosinst_data resource:

```
control_flow:
  CONSOLE = ???
  PROMPT = no
  INSTALL_TYPE = CC_EVAL
  INSTALL_METHOD = overwrite
  TCB = yes
  DESKTOP = NONE or CDE
  ENABLE_64BIT_KERNEL = yes
  CREATE_JFS2_FS = yes
  ALL_DEVICES_KERNELS = no
  FIREFOX_BUNDLE = no
  HTTP_SERVER_BUNDLE = no
  KERBEROS_5_BUNDLE = no
  SERVER_BUNDLE = no
  ALT_DISK_INSTALL_BUNDLE = no
```

locale:

```
CULTURAL_CONVENTION = en_US or C
MESSAGES = en_US or C
```

The NIM master cannot be configured as a CAPP/EAL4+ system and cannot be connected to the same network with other CAPP/EAL4+ systems. When initiating the installation from the NIM master, the **Remain NIM client after install SMIT** menu option must be set to No. After a NIM client is installed as a CAPP/EAL4+ system, the NIM client must be removed from the NIM master's network, and additional software installations and updates cannot be performed using the NIM master.

An example situation is to have two network environments; the first network consists of the NIM master and the non-CAPP/EAL4+ systems; the second network consists only of CAPP/EAL4+ systems. Perform the NIM installation on the NIM client. After the installation has completed, disconnect the newly installed CAPP/EAL4+ system from the NIM master's network and connect the system to the evaluated network.

A second example consists of one network. The NIM master is not connected to the network when other systems are operating in the evaluated configuration, and CAPP/EAL4+ systems are not connected to the network during NIM installation.

CAPP/EAL4+ software bundle:

When the **CAPP/EAL4+** option is selected, the contents of the **/usr/sys/inst.data/sys_bundles/CC_EVAL.BOS.autoi** installation bundle are installed.

You can optionally select to install the graphics software bundle and the documentation services software bundle with the **CAPP/EAL4+** option selected. If you select the **Graphics Software** option with the **CAPP/EAL4+** option, the contents of the **/usr/sys/inst.data/sys_bundles/CC_EVAL.Graphics.bnd** software bundle are installed. If you select the Documentation Services Software option with the **CAPP/EAL4+** option, the contents of the **/usr/sys/inst.data/sys_bundles/CC_EVAL.DocServices.bnd** software bundle are installed.

After the Licensed Program Products (LPPs) have been installed, the system changes the default configuration to comply with the CAPP/EAL4+ requirements. The following changes are made to the default configuration:

- Remove **/dev/echo** from the **/etc/pse.conf** file.
- Instantiate streams devices.
- Allow only root to access removable media.
- Remove non-CC entries from the **inetd.conf** file.
- Change various file permissions.
- Register symbolic links in the **sysck.cfg** file.
- Register devices in the **sysck.cfg** file.
- Set default user and port attributes.
- Configure the **doc_search** application for browser use.
- Remove **httpdlite** from the **inittab** file.
- Remove **writesrv** from the **inittab** file.
- Remove **mkatmpvc** from the **inittab** file.
- Remove **atmsvcd** from the **inittab** file.
- Disable **snmpd** in the **/etc/rc.tcpip** file.
- Disable **hostmibd** in the **/etc/rc.tcpip** file.
- Disable **snmpmibd** in the **/etc/rc.tcpip** file.
- Disable **aixmibd** in the **/etc/rc.tcpip** file.
- Disable **muxatmd** in the **/etc/rc.tcpip** file.
- NFS port (2049) is a privileged port.
- Add missing events to the **/etc/security/audit/events** file.
- Ensure that the loopback interface is running.
- Create synonyms for **/dev/console**.
- Enforce default X-server connection permissions.
- Change the **/var/docsearch** directory so that all files are world-readable.
- Add Object Data Manager (ODM) stanzas to set the console permissions.
- Set permissions on BSD-style ptys to 000.
- Disable **.netrc** files.
- Add patch directory processing.

Graphical user interface:

The CAPP/EAL4+ compliant system includes the X Windows System as a graphical user interface.

X Windows provides a mechanism for displaying graphical clients, such as clocks, calculators, and other graphical applications, as well as multiple terminal sessions using the **aixterm** command. The X Windows System is started with the **xinit** command from the initial command line after a user has logged in at the host's console.

To start an X Windows session, type:

```
xinit
```

This command starts the X Windows server with local access mechanisms enabled for the invoker only. X Windows clients that are set-UID to root will be able to access the X Windows server via the UNIX[®] domain socket using the root override on the access restrictions. X Windows clients that are set-UID to other users or that are started by other users will not be able to access the X Windows server. This restriction prevents other users of a host from gaining unauthorized access to the X Windows server.

Installing a LSPP/EAL4+ system:

RBAC is automatically enabled when this option is selected.

To set the LSPP/EAL4+ option during a BOS installation, do the following:

The installation options are available by typing 3 to change the **Security Model** and typing 4 to view the **More Options** field in the Installation and Settings window. These options vary based on installation type (overwrite, preservation, or migration) and security options. For LSPP, the installation method is new or complete overwrite. Choose **LSPP/EAL4+ configuration install** .

For more information about RBAC, see Role Based Access Control (RBAC).

LSPP/EAL4+ configuration installation (only available with Trusted AIX):

The **LSPP/EAL4+ configuration install** option installs Trusted AIX in LSPP/EAL4+ configured mode. LSPP/EAL4+ configured mode provides for further restrictive security as compared to the Trusted AIX installation.

If you are performing a nonprompted installation using a customized **bosinst.data** file, the **INSTALL_TYPE** field must be blank and the **TRUSTED_AIX** field should be set to yes and the following fields must be set as follows:

```
control_flow:  
  CONSOLE = ???  
  PROMPT = yes  
  INSTALL_TYPE =  
  TRUSTED_AIX = yes  
  INSTALL_METHOD = overwrite  
  TCB = yes  
  DESKTOP = NONE  
  ENABLE_64BIT_KERNEL = yes  
  CREATE_JFS2_FS = yes  
  ALL_DEVICES_KERNELS = no  
  FIREFOX_BUNDLE = no  
  HTTP_SERVER_BUNDLE = no  
  KERBEROS_5_BUNDLE = no  
  SERVER_BUNDLE = no  
  ALT_DISK_INSTALL_BUNDLE = no
```

```
locale:  
  CULTURAL_CONVENTION = en_US or C  
  MESSAGES = en_US or C
```

For more information about Trusted AIX, see Trusted AIX.

LSPP/EAL4+ and the Network Installation Management environment:

Installation of LSPP/EAL4+ technology clients can be performed using the Network Installation Management (NIM) environment.

The NIM master is configured to provide the resources needed to install the appropriate LSPP/EAL4+ level of AIX 6.1. NIM clients may then be installed using the resources located on the NIM master. You can perform a nonprompted NIM installation of the client by setting the following fields in the bosinst_data resource:

```
control_flow:
  CONSOLE = ???
  PROMPT = no
  INSTALL_TYPE =
  TRUSTED_AIX = yes
  INSTALL_METHOD = overwrite
  TCB = yes
  DESKTOP = NONE
  ENABLE_64BIT_KERNEL = yes
  CREATE_JFS2_FS = yes
  ALL_DEVICES_KERNELS = no
  FIREFOX_BUNDLE = no
  HTTP_SERVER_BUNDLE = no
  KERBEROS_5_BUNDLE = no
  SERVER_BUNDLE = no
  ALT_DISK_INSTALL_BUNDLE = no

locale:
  CULTURAL_CONVENTION = en_US or C
  MESSAGES = en_US or C
```

The NIM master cannot be configured as a LSPP/EAL4+ system and cannot be connected to the same network with other LSPP/EAL4+ systems. When initiating the installation from the NIM master, the **Remain NIM client after install SMIT** menu option must be set to No. After a NIM client is installed as a LSPP/EAL4+ system, the NIM client must be removed from the NIM master's network, and additional software installations and updates cannot be performed using the NIM master.

An example situation is to have two network environments; the first network consists of the NIM master and the non-LSPP/EAL4+ systems; the second network consists only of LSPP/EAL4+ systems. Perform the NIM installation on the NIM client. After the installation has completed, disconnect the newly installed LSPP/EAL4+ system from the NIM master's network and connect the system to the evaluated network.

A second example consists of one network. The NIM master is not connected to the network when other systems are operating in the evaluated configuration, and LSPP/EAL4+ systems are not connected to the network during NIM installation.

CAPP/EAL4+ and LSPP/EAL4+ systems physical environment:

The CAPP/EAL4+ and LSPP/EAL4+ systems have specific requirements for the environment in which they are run.

The requirements are as follows:

- Physical access to the systems must be restricted so that only authorized administrators can use the system consoles.
- The Service Processor is not connected to a modem.
- Physical access to the terminals is restricted to authorized users.
- The physical network is secure against eavesdropping and spoofing programs (also called Trojan horse programs). When communicating over insecure lines, additional security measures, such as encryption, are needed.

- Communication with other systems that are not AIX 6.1 CAPP/EAL4+ or LSPP/EAL4+ systems, or are not under the same management control, is not permitted.
- Only IPv4 is to be used when communicating with other CAPP/EAL4+ and LSPP/EAL4+ systems. IPv6 is included in the evaluated configuration, but only the functional capabilities of IPv6 that are also supported by IPv4 are included.
- Users must not be allowed to change the system time.
- Systems in an LPAR environment cannot share PHBs.

CAPP/EAL4+ and LSPP/EAL4+ systems organizational environment:

Certain procedural and organizational requirements must be met for a CAPP/EAL4+ and LSPP/EAL4+ systems.

The following requirements must be met:

- Administrators must be trustworthy and well trained.
- Only users authorized to work with the information on the systems are granted user IDs on the system.
- Users must use high-quality passwords (as random as possible and not affiliated with the user or the organization). For information about setting up password rules, see “Passwords” on page 58.
- Users must not disclose their passwords to others.
- Administrators must have sufficient knowledge to manage security critical systems.
- Administrators must work in accordance with the guidance provided by the system documentation.
- Administrators must log in with their personal ID and use the **su** command to switch to superuser mode for administration.
- Passwords generated for system users by administrators must be transmitted securely to the users.
- Those who are responsible for the system must establish and implement the necessary procedures for the secure operation of the systems.
- Administrators must ensure that the access to security-critical system resources is protected by appropriate settings of permission bits and ACLs.
- The physical network must be approved by the organization to carry the most sensitive data held by the systems.
- Maintenance procedures must include regular diagnostics of the systems.
- Administrators must have procedures in place that ensure a secure operation and recovery after a system failure.
- The *LIBPATH* environment variable should not be changed, because this might result in a trusted process loading an untrusted library.
- Wiretapping and trace software (tcpdump, trace) must not be used on an operational system.
- Anonymous protocols such as HTTP may only be used for public information (for example, the online documentation).
- Only TCP-based NFS can be used.
- Access to removable media is not to be given to users. The device files are to be protected by appropriate permission bits or ACLs.
- Only root authority is used when administering AIX. None of the role-based and group-based administration-delegation features, nor the privilege mechanism of AIX, are included in the CAPP/EAL4+ compliance.
- Administrators must not use dynamic partitioning to allocate and deallocate resources. Partition configuration may only be performed while no partitions at all are running.

CAPP/EAL4+ system operational environment:

Certain operational requirements and procedures must be met for a CAPP/EAL4+ system.

The following requirements and procedures must be met:

- If using a Hardware Management Console (HMC), the HMC is located in a physically controlled environment.
- Only authorized personnel can access to the operational environment and the HMC.
- If using an HMC, the HMC can only be used for the following tasks:
 - Initial configuration of the partitions. A partition cannot be active during the configuration process.
 - Restarting of "hanging" partitions
- The HMC must not be used throughout operation of the configured system.
- The system's "call home" feature must be disabled.
- Remote modem access to the system must be disabled.
- If AIX runs in an LPAR-enabled environment, the administrator should check with the LPAR documentation for requirements on the EAL4+ operation of logical partitions.
- The service authority feature must be disabled on logical partitions.

CAPP/EAL4+ system configuration:

You can configure the Controlled Access Protection Profile (CAPP) and Evaluation Assurance Level 4+ (EAL4+) system.

The **system**, **sys**, **adm**, **uucp**, **mail**, **security**, **cron**, **printq**, **audit** and **shutdown** groups are considered administrative groups. Only trusted users should be added to this group.

Administration:

Administrators must log in with their personal user account and use the **su** command to become the root user for the administration of the system.

To effectively prevent guessing the root account's password, allow only authorized administrators to use the **su** command on the root account. To ensure this, do the following:

1. Add an entry to the **root** stanza of the **/etc/security/user** file as follows:

```
root:
  admin = true
  .
  .
  .
  sugroups = SUADMIN
```

2. Define group in the **/etc/group** file containing only the user IDs of authorized administrators as follows:

```
system:!:0:root,paul
staff:!:1:invscout,julie
bin:!:2:root,bin
.
.
.
SUADMIN:!:13:paul
```

Administrators must also adhere to the following procedures:

- Establish and implement procedures to ensure that the hardware, software and firmware components that comprise the distributed system are distributed, installed, and configured in a secure manner.
- Ensure that the system is configured so that only an administrator can introduce new trusted software into the system.
- Implement procedures to ensure that users clear the screen before logging off from serial login devices (for example, IBM 3151 terminals).

User and port configuration:

AIX configuration options for users and ports must be set to satisfy the requirements of the evaluation. The actual requirement is that the probability of correctly guessing a password should be at least 1 in 1,000,000, and the probability of correctly guessing a password with repeated attempts in one minute should be at least 1 in 100,000.

The `/etc/security/user` file shown in the following example uses the `/usr/share/dict/words` dictionary list. The `/usr/share/dict/words` file is contained in the `bos.data` fileset. You must install the `bos.data` fileset prior to configuring the `/etc/security/user` file. The recommended values for the `/etc/security/user` file are the following:

```
default:
  admin = false
  login = true
  su = true
  daemon = true
  rlogin = true
  sugroups = ALL
  admgroups =
  ttys = ALL
  auth1 = SYSTEM
  auth2 = NONE
  tpath = nosak
  umask = 077
  expires = 0
  SYSTEM = "compat"
  logintimes =
  pwdwarntime = 5
  account_locked = false
  loginretries = 3
  histexpire = 52
  histsize = 20
  minage = 0
  maxage = 8
  maxexpired = 1
  minalpha = 2
  minother = 2
  minlen = 8
  mindiff = 4
  maxrepeats = 2
  dictionlist = /usr/share/dict/words
  pwdchecks =
  dce_export = false

root:
  rlogin = false
  login = false
```

The default settings in the `/etc/security/user` file should not be overwritten by specific settings for single users.

Note: Setting `login = false` in the root stanza prevents direct root login. Only user accounts that have `su` privileges for the root account will be able to log in as the root account. If a Denial of Service attack is launched against the system that sends incorrect passwords to the user accounts, it could lock all the user accounts. This attack might prevent any user (including administrative users) from logging into the system. Once a user's account is locked, the user will not be able to log in until the system administrator resets the user's `unsuccessful_login_count` attribute in the `/etc/security/lastlog` file to be less than the value of the `loginretries` user attribute. If all the administrative accounts become locked, you might need to reboot the system into maintenance mode and run the `chsec` command. For more information about using the `chsec` command, see "User account control" on page 50.

The suggested values for the `/etc/security/login.cfg` file are the following:

```
default:
sak_enabled = false
logintimes =
logindisable = 4
logininterval = 60
loginreenable = 30
logindelay = 5
```

List of setuid/setgid programs:

A list of trusted applications is created for CAPP-enabled AIX systems.

The **suid/sgid** bits are turned off for all non-trusted programs that are owned by root or a trusted group. The only programs on the system after a CAPP install that are either **suid** and owned by root or **sgid** and owned by one of these trusted groups are **system, sys, adm, uucp, mail, security, cron, printq, audit,** and **shutdown**. Only add trusted users to these groups.

The list of trusted applications is created by considering all applications that fall into at least one of the following categories:

- SUID root bit for the corresponding application is enabled
- SGID bit to one of the trusted groups is enabled
- Applications that access any of the trusted databases according to the administrator guidance document
- Applications that either implement or provide access to any security function, such as:
 - **/usr/bin/at**
 - **/usr/sbin/audit**
 - **/usr/sbin/auditbin**
 - **/usr/sbin/auditcat**
 - **/usr/sbin/auditmerge**
 - **/usr/sbin/auditpr**
 - **/usr/sbin/auditselect**
 - **/usr/bin/batch**
 - **/usr/bin/chsh**
 - **/usr/sbin/chtcb**
 - **/usr/sbin/cron**
 - **/usr/bin/crontab**
 - **/usr/sbin/diag**
 - **/usr/sbin/ftpd**
 - **/usr/sbin/inetd**
 - **/usr/bin/logout**
 - **/usr/bin/passwd**
 - **/usr/sbin/ping**
 - **/usr/sbin/rexecd**
 - **/usr/sbin/rlogind**
 - **/usr/sbin/rpc.mountd**
 - **/usr/sbin/rshd**
 - **/usr/bin/setgroups**
 - **/usr/bin/setsenv**
 - **/usr/bin/su**
 - **/usr/sbin/telnetd**

- /usr/sbin/tsm
- /usr/lpp/X11/bin/xlock
- /usr/lpp/diagnostics/bin/uformat

Note: The **setuid** bit for the **ipcs** command should be removed by the system administrator. The system administrator should run the **chmod u-s /usr/bin/ipcs** and **chmod u-s /usr/bin/ipcs64** commands.

Hard disk erasure:

AIX allows hdisks to be erased using the **Format media** service aid in the AIX diagnostic package. The diagnostic package is fully documented in the *Diagnostic Information for Multiple Bus Systems* book, as well as your hardware user's guide.

To erase a hard disk, run the following command:

```
diag -T "format"
```

This command will start the **Format media** service aid in a menu driven interface. If prompted, select your terminal.

You will then be presented with a resource selection list. Select the hdisk devices you want to erase from this list and commit your changes according to the instructions on the screen.

After committing your selections, select **Erase Disk** from the menu. You are then asked to confirm your selection. Choose **Yes**.

You are then asked if you want to **Read data from drive** or **Write patterns to drive**. Select **Write patterns to drive**.

You then have the opportunity to modify the disk erasure options. After you specify the options you prefer, select **Commit Your Changes**. The disk is erased.

Note: It can take a long time for this process to complete.

Resource limits:

When setting resource limits in the **/etc/security/limits** file, make sure that the limits correspond to the needs of the processes on the system.

In particular, the **stack** and **rss** sizes should *never* be set to unlimited. An unlimited stack might overwrite other segments of the running process, and an unlimited **rss** size allows a process to use all real memory, therefore creating resource problems for other processes. The **stack_hard** and **rss_hard** sizes should also be limited.

Audit subsystem:

There are several procedures to help protect the audit subsystem.

- Configure the audit subsystem to record all the relevant security activities of the users. To ensure that the file space needed for auditing is available and is not impaired by other consumers of file system space, set up a dedicated file system for audit data.
- Protect audit records (such as audit trails, bin files, and all other data stored in **/audit**) from non-root users.
- For the CAPP/EAL4+ system, **bin** mode auditing must be set up when the audit subsystem is used. For information about how to set up the audit subsystem, refer to "Setting up auditing" on page 126.
- At least 20 percent of the available disk space in a system should be dedicated to the audit trail.

- If auditing is enabled, the *binmode* parameter in the start stanza in the */etc/security/audit/config* file should be set to *panic*. The *freespace* parameter in the bin stanza should be configured at minimum to a value that equals 25 percent of the disk space dedicated to the storage of the audit trails. The *bytethreshold* and *binsize* parameters should each be set to 65 536 bytes.
- Copy audit records from the system to permanent storage for archival.

System services:

The following table is a list of standard system services on a Controlled Access Protection Profile (CAPP) and Evaluation Assurance Level 4+ (EAL4+) system.

This table shows the standard system services running on a CAPP/EAL4+ system (if there is no graphics card).

Table 1. Standard System Services

UID	Command	Description
root	/etc/init	Init process
root	/usr/sbin/syncd 60	File system sync daemon
root	/usr/sbin/srcmstr	SRC master daemon
root	/usr/sbin/cron	CRON facility with AT support
root	/usr/ccs/bin/shlap64	Shared Library Support Daemon
root	/usr/sbin/syslogd	Syslog daemon
root	/usr/lib/errdemon	AIX error log daemon
root	/usr/sbin/getty /dev/console	getty / TSM
root	/usr/sbin/portmap	Portmapper for NFS and CDE
root	/usr/sbin/biod 6	NFS Client
root	/usr/sbin/rpc.lockd	NFS lock daemon
daemon	/usr/sbin/rpc.statd	NFS stat daemon
root	/usr/sbin/rpc.mountd	NFS mount daemon
root	/usr/sbin/nfsd	NFS server daemon
root	/usr/sbin/inetd	Inetd master daemon
root	/usr/sbin/uprintfd	Kernel print daemon
root	/usr/sbin/qdaemon	Queuing daemon
root	/usr/lpp/diagnostics/bin/diagd	Diagnostics
root	/usr/sbin/secdapcintd	AIX LDAP authentication daemon
root	/usr/sbin/gssd	Services kernel requests for GSS operation
root	/usr/sbin/nfsrgyd	Name translation service for NFS v4 servers/clients

Running a CAPP/EAL4+ distributed system:

To run a distributed system that is CAPP/EAL4+ compliant, all users must have identical user IDs on all systems. Although this can be achieved with NIS, the result is not secure enough for a CAPP/EAL4+ system.

This section describes a distributed setup that ensures that the user IDs are identical on all systems that are CAPP/EAL4+ compliant.

The master system stores the identification and authentication data (user and group configuration) for the whole distributed system.

Authentication data can be changed by any administrator by using tools, such as SMIT, on any system. Authentication data is physically changed on the master.

All shared identification and authentication data comes from the **/etc/data.shared** directory. The regular identification and authentication files are replaced by symbolic links into the **/etc/data.shared** directory.

Shared files in the distributed system:

The following files are shared in the distributed system. Typically, they come from the **/etc/security** directory.

/etc/group

The **/etc/group** file

/etc/hosts

The **/etc/hosts** file

/etc/passwd

The **/etc/passwd** file

/etc/security/ids

The next available user and group ID

/etc/security/.profile

The default **.profile** file for new users

/etc/security/acl

The **/etc/security/acl** file stores system-wide ACL definitions for protected services that will be reactivated at the next system boot by the **/etc/rc.tcpip** file.

/etc/security/audit/bincmds

Bin-mode auditing commands for this host

/etc/security/audit/config

Local audit configuration

/etc/security/audit/events

List of audit events and formats

/etc/security/audit/objects

List of audited objects on this host

/etc/security/audit/streamcmds

Stream-mode auditing commands for this host

/etc/security/envIRON

Per-user environmental variables

/etc/security/group

Extended group information from the **/etc/security/group** file

/etc/security/limits

Per-user resource limits

/etc/security/passwd

Per-user passwords

/etc/security/priv

Ports that are to be designated as privileged when the system starts are listed in the **/etc/security/priv** file

/etc/security/services

Ports listed in the **/etc/security/services** file are considered exempt from ACL checks

/etc/security/user

Per-user and default user attributes

Nonshared files in the distributed system:

The following files in the **/etc/security** directory are not to be shared in the distributed system, but are to remain host-specific:

/etc/security/failedlogin

Log file for failed logins per host

/etc/security/lastlog

Per-user information about the last successful and unsuccessful logins on this host

/etc/security/login.cfg

Host-specific login characteristics for trusted path, login shells, and other login-related information

/etc/security/portlog

Per-port information for locked ports on this host

The automatically generated backup files of the shared files are also nonshared. Backup files have the same name as the original file, but have a lowercase letter **o** prepended.

Setting up the distributed system (Master):

On the master, a new logical volume is created that holds the file system for the identification and authentication data. The logical volume is named **/dev/hd10sec** and it is mounted on the master system as **/etc/data.master**.

To generate the necessary changes on the master system, run the **mkCCadmin** command with the IP address and host name of the master, as follows:

```
mkCCadmin -m -a ipaddress hostname
```

Setting up the distributed system (all systems):

You can set up the distributed system for all systems.

All data that is to be shared is moved to the **/etc/data.shared** directory. At startup, all systems will mount the master's **/etc/data.master** directory over the **/etc/data.shared** directory. The master itself uses a loopback mount.

Client systems are set up by running the following:

```
mkCCadmin -a ipaddress hostname
```

To change the client to use a different master, use the **chCCadmin** command.

After a system has been integrated into the distributed identification and authentication system, the following additional inittab entries are generated:

isCChost

Initializes the system to CAPP/EAL4+ mode.

rcCC Clears all DACinet ACLs and opens only the ports needed for the portmapper and NFS. It then mounts the shared directory.

rcdacinet

Loads additional DACinet ACLs that the administrator might have defined.

When running the distributed system, consider the following:

- Administrators must make sure that the shared data is mounted before changing shared configuration files to ensure that the shared data is seen on all systems.
- Changing the root password is the only administrative action that is permitted while the shared directory is not mounted.

Using the DACinet feature for user-based and port-based network access control:

The DACinet feature can be used to restrict the access of users to TCP ports.

For more information about DACinet, see “User based TCP port access control with discretionary access control for internet ports” on page 206. For example, when using DACinet to restrict access to port TCP/25 inbound to root only with the DACinet feature, only root users from CAPP/EAL4+ compliant hosts can access this port. This situation limits the possibility of regular users spoofing e-mail by using telnet to connect to port TCP/25 on the victim.

To activate the ACLs for TCP connections at boot time, the `/etc/rc.dacinet` script is run from `/etc/inittab`. It will read the definitions in the `/etc/security/acl` file and load ACLs into the kernel. Ports which should not be protected by ACLs should be listed in the `/etc/security/services` file, which uses the same format as the `/etc/services` file.

Assuming a subnet of 10.1.1.0/24 for all the connected systems, the ACL entries to restrict access to the root user only for X (TCP/6000) in the `/etc/security/acl` file would be as follows:

```
6000 10.1.1.0/24 u:root
```

Installing additional software on a CAPP/EAL4+ compliant system:

The administrator can install additional software on the CAPP/EAL4+ compliant system. If the software is not run by the root user or with root-user privileges, this will not invalidate the CAPP/EAL4+ compliance. Typical examples include office applications that are run only by regular users and have no SUID components.

Additionally, installed software that runs with root-user privileges invalidates the CAPP/EAL4+ compliance. This means, for example, drivers for the older JFS should not be installed, as they are running in kernel mode. Additional daemons that are run as root (for example, an SNMP daemon) also invalidates the CAPP/EAL4+ compliance. A CAPP/EAL4+ enabled system cannot be upgraded (normally).

A CAPP/EAL4+ compliant system is rarely used in the evaluated configuration, especially in a commercial environment. Typically, additional services are needed, so that the production system is based on an evaluated system, but does not comply with the exact specification of the evaluated system.

NSF v4 Access Control Lists and contents policy:

An NFS v4 Access Control List (ACL) contains the **Type**, **Mask**, and **Flags** fields.

The following is a description of these fields:

- The **Type** field contains one of the following values:
 - ALLOW – Grants the subject, specified in the **Who** field, the permission(s) specified in the **Mask** field.
 - DENY – Denies the subject, specified in the **Who** field, the permission(s) specified in the **Mask** field.
- The **Mask** field contains one or more of the following fine grained permission values:
 - READ_DATA / LIST_DIRECTORY – Read the data from a non-directory object or list the objects in a directory.
 - WRITE_DATA / ADD_FILE – Write data into a non-directory object or add a non-directory object to a directory.

- APPEND_DATA / ADD_SUBDIRECTORY – Append data into a non-directory object or add a subdirectory to a directory.
- READ_NAMED_ATTRS – Read the named attributes of an object.
- WRITE_NAMED_ATTRS – Write the named attributes of an object.
- EXECUTE – Execute a file or traverse/search a directory.
- DELETE_CHILD – Delete a file or directory within a directory.
- READ_ATTRIBUTES – Read the basic (non-ACL) attributes of a file.
- WRITE_ATTRIBUTES – Change the times associated with a file or directory.
- DELETE – Delete a file or directory.
- READ_ACL – Read the ACL.
- WRITE_ACL – Write the ACL.
- WRITE_OWNER – Change the owner and group.
- SYNCHRONIZE – Synchronize access (exists for compatibility with other NFS v4 clients, but has no implemented function).
- **Flags** field – This field defines the inheritance capabilities of directory ACLs and indicates whether the **Who** field contains a group or not. This field contains zero or more of the following flags:
 - **FILE_INHERIT** – Specifies that, in this directory, newly created non-directory objects inherit this entry.
 - **DIRECTORY_INHERIT** – Specifies that, in this directory, newly created subdirectories inherit this entry.
 - **NO_PROPAGATE_INHERIT** – Specifies that, in this directory, newly created subdirectories inherit this entry, but these subdirectories do not pass this entry to their newly created subdirectories.
 - **INHERIT_ONLY** – Specifies that this entry does not apply to this directory, only to the newly created objects that inherit this entry.
 - **IDENTIFIER_GROUP** – Specifies that the **Who** field represents a group; otherwise, the **Who** field represents a user or a special **Who** value.
- **Who** field – This field contains one of the following values:
 - User – Specifies the user to whom this entry applies.
 - Group – Specifies the group to which this entry applies.
 - Special – This attribute can be one of the following values:
 - OWNER@ – Specifies that this entry applies to the owner of the object.
 - GROUP@ – Specifies that this entry applies to the owning group of the object.
 - EVERYONE@ – Specifies that this entry applies to all users of the system including the owner and group.

If the ACL is empty, only a subject with an effective UID of 0 can access the object. The owner of an object implicitly has the following mask values regardless of what the ACL might or might not contain:

- READ_ACL
- WRITE_ACL
- READ_ATTRIBUTES
- WRITE_ATTRIBUTES

The APPEND_DATA value is implemented as WRITE_DATA . Effectively, there's no functional distinction between the WRITE_DATA value and the APPEND_DATA value. Both values must be set or unset in unison.

Object ownership can be modified through the use of the WRITE_OWNER value. When the owner or group is changed, the **setuid** bit is turned off. The inheritance flags only have meaning in a directory's ACL and only apply to objects that are created in the directory after the inheritance flags have been set (for example, existing objects are not affected by inheritance changes to the parent directory's ACL). The

entries in an NFS v4 ACL are order dependent. To determine if the requested access is allowed, each entry is processed in order. Only entries that have the following values are considered:

- A **Who** field that matches the effective UID
- A user that is specified in the entry or effective GID
- A group that is specified in the entry of the subject

Each entry is processed until all of the bits of the requester's access have been ALLOWED. After an access type has been ALLOWED by an entry, it is no longer considered in the processing of later entries. If a DENY entry is encountered where the requester's access for that mask value is necessary and undetermined, the request is denied. If the evaluation reaches the end of the ACL, the request is denied.

The maximum supported ACL size is 64 KB. Each entry in an ACL is of variable length and 64 KB is the only limit on an entry.

The WRITE OWNER value:

The NFS v4 policy provides control over who can read and write the attributes of an object.

A subject with an effective UID 0 can always override the NFS v4 policy. The object owner can allow others to read and write the attributes of an object using the READ_ATTRIBUTES, WRITE_ATTRIBUTES, READ_NAMED_ATTRS, and WRITE_NAME_ATTRS attributes of the ACL mask. The owner can control who can read and write the ACL using the READ_ACL and WRITE_ACL values of the ACL mask. The object owner always has READ_ATTRIBUTES, WRITE_ATTRIBUTES, READ_ACL, and WRITE_ACL access. The object owner can also allow others to change the owner and group of the object using the WRITE_OWNER attribute. An object owner cannot change the owner or group of the object by default, but the object owner can add a WRITE_OWNER entry to the ACL specifying themselves, or the object can inherit an ACL entry that specifies a WRITE_OWNER entry with a **Who** value of OWNER@. When the owner or group is changed, the **setuid** bit is turned off.

The following are some exceptions to the rules:

- If the object is owned by UID 0, only UID 0 can change the owner, but the group can still be changed by a subject with the WRITE_OWNER attribute.
- Assuming the object has the WRITE_OWNER attribute for the subject, in versions of AIX 5.3 prior to Technology Level 5300-05, if the object has a non-UID 0 owner, the owner can only be changed to another non-UID 0 user. In AIX with 5300-05 and later, if the object has a non-UID 0 owner, the owner can only be changed to the EUID of the subject attempting to change the owner.
- The group can be changed to any group in the subject's concurrent group set with the exception that it can never be changed to GID 0 or GID 7 (system or security), even if these two groups are in the concurrent group set of the subject.

LDAP-based and file-based administrative database supported:

The evaluation does not support NFS administrative database. Authentication methods such as DCE and NIS are not supported.

The evaluation supports only the following:

- File-based authentication (default)
- UNIX-style LDAP-based authentication (use LDAP server ITDSv 6.0)

For more information about file-based authentication, see the User Authentication.

LDAP authentication:

LDAP-based I&A is configured in the "UNIX-type" authentication mode. In this mode, the administrative data (including user names, IDs, and passwords) are stored in LDAP where access to the data is limited to the LDAP administrator.

When a user logs into the system, the system binds to the LDAP server using the LDAP administrator account over an SSL connection, retrieves the necessary data for the user (including the password) from LDAP, and then performs authentication using the data retrieved from LDAP. The system maintains an administrative database on an LDAP server. The remaining hosts import the administrative data from the same LDAP server through the same mechanism previously described. The system maintains a consistent administrative database by making all administrative changes on the designated LDAP server. A user ID on any computer refers to the same individual on all other computers. In addition, the password configuration, name-to-UID mappings, and other data are identical on all hosts in the distributed system.

For more information on LDAP authentication setup, see Light Directory Access Protocol. For more information in setting up SSL on LDAP, see Setting up SSL on the LDAP server and Setting up SSL on the LDAP client.

LDAP server:

The **mksecldap -s** command sets up an AIX system as an LDAP server for security authentication and data management.

Perform the following tasks:

- Use the RFC2307AIX schema with the **-S** option.
- Set the server to use SSL by using the **-k** option. This requires installing the **GSKit** fileset and the **ldap.max_crypto_server** fileset. Use the **gsk7ikm** utility to generate the key pairs for the directory server.

The LDAP user options must be set to satisfy the requirements of the evaluation. The RFC2370AIX schema defines the user attributes. Use the same values as described in CAPP/EAL4+ system configuration. The ITDS administrators are not forced to periodically change their passwords (for example, there's no **MaxAge** value for administrative passwords). Because of this, the LDAP administrative password must be changed as often as an AIX user (**MaxAge** = 8 (in weeks)).

In ITDS 5.2, the authentication failure handling does not apply to Directory Administrator or to the members of the administrative group. Password composition rules also do not apply to administrative accounts. These need to be enforced if ITDS 5.2 is used.

If the administrator does not use a common LDAP database backend for user management, the administrator must somehow ensure that the database that contains users credentials (listed below) is maintained consistently among the different TOE systems part of one network:

- **/etc/group**
- **/etc/passwd**
- **/etc/security/ids**
- **/etc/security/profile**
- **/etc/security/environ**
- **/etc/security/group**
- **/etc/security/limits**
- **/etc/security/passwd**
- **/etc/security/user**

LDAP client:

The **mksecldap -c** command sets up an AIX system as an LDAP client for security authentication and data management.

Perform the following tasks:

- Using the **mksecdap -c** command, specify **unix_auth** for the **authType** with the **-A** option.
- Set the client to use SSL by using the **-k** option in the **mksecdap -c** command. Specifying the client SSL key requires installing the **GSKit** fileset and **ldap.max_crypto_client** fileset. Use the **gsk7ikm** utility to generate the key pairs for the directory server.

For more information about LDAP, see the following documentation:

- Redbook: Integrating AIX into Heterogenous LDAP Environments.
- Whitepaper: Configuring an IBM Directory Server for User Authentication and Management in AIX.
- Whitepaper: Configuring an AIX Client System for User Authentication and Management Through LDAP.

NFS v4 Client/Server and Kerberos:

The NFS v4 Client/Server environment includes LDAP for maintaining authentication data and Kerberos for establishing trusted channel between NFS v4 clients and servers. The evaluated configuration supports NAS v1.4 for Kerberos and ITDS v6.0 (LDAP server) for the user database.

NAS v1.4 (Kerberos Version 5 Server) must be configured to use LDAP for its database. Kerberos tickets previously granted by the Kerberos server are valid until they expire.

When you are using Kerberos authentication, the credential used in remote procedure calls initiated by a user are associated with the current Kerberos ticket held by the user and is not influenced by the real or effective UID of the process. When you are accessing an NFS remote file system using Kerberos authentication while running a **setuid** program, the UID seen at the server is based on the Kerberos identity, not the UID that owns the **setuid** program being run.

The evaluated configuration involves setting up NFS to use RPCSEC-GSS security. For more information, see Network File System, Configuring an NFS server, and Configuring an NFS client. When setting up the server, choose Kerberos authentication and enable enhanced security on the server. You can enable this through SMIT using the **chnfs** command. The **chnfs** command has the option to enable **RPCSEC_GSS** security. When you are setting up the client, follow the instructions to use Kerberos in Configuring an NFS client. See Setting up a network for RPCSEC-GSS for the instructions to set up the Kerberos data server with DES3 encryption for security. The evaluated configuration supports only des3 encryption.

Password rules:

The evaluated configuration should have these values for password rules when you are using the Kerberos server with LDAP as the database.

For more information about password rules, see "Chapter 9. Managing Network Authentication Service passwords" in the *IBM Network Authentication Service Version 1.4 for AIX, Linux and Solaris Administrator's and User's Guide*.

mindiff	= 4
maxrepeats	= 2
minalpha	= 2
minother	= 2
minlen	= 8
minage	= 0
histsize	= 10

To have the AIX NFS v4 client and AIX NFS v4 server securely communicate explicitly using only DES3 encrypes, create the "nfs/hostname" server principal with DES3 enctype (such as des3-cbc-sha1), along

with the corresponding entry in the **keytab** file (using **kadmin** interface) and have DES3 (such as **des3-cbc-sha1**) as the first entry in the **default_tgs_ectypes** section of the **/etc/krb5/krb5.conf** file on the NFS v4 client machine.

For more information about securing NFS, see *Securing NFS in AIX An Introduction to NFS v4 in AIX 5L Version 5.3*.

Virtual I/O Server:

The Virtual I/O Server (VIOS) resides in a separate LPAR partition and provides basic discretionary access control between VIOS SCSI device drivers acting on behalf of LPAR partitions and SCSI-based logical volumes and physical volumes through mappings.

An LPAR partition (through a VIOS SCSI device driver) may be mapped to 0 or more logical and physical volumes, but a volume can only be mapped to one LPAR partition. This mapping limits an LPAR partition to only the volumes assigned to it. VIOS also controls the mapping of VIOS Ethernet adapter device drivers to VIOS Ethernet device drivers acting on behalf of groups of LPAR partitions sharing a virtual network. In the evaluated configuration, only a one-to-one mapping of an Ethernet adapter device driver to an Ethernet device driver acting on behalf of a group of LPAR partitions is allowed. The one-to-one mapping is configured by the administrator and enforced by the device drivers. Also, the Ethernet packets must not be tagged with a VLAN tag in the evaluated configuration. This mechanism can be used to limit which LPAR partitions see certain Ethernet packets.

The VIOS interface should be protected from access by unprivileged users. The VIOS user options must be set to satisfy the requirements of the evaluation. The actual requirement is that the probability of correctly guessing a password should be at least 1 in 1,000,000 and the probability of correctly guessing a password with repeated attempts in one minute should be at least 1 in 100,000. The following parameters should be changed for the user in the **/etc/security/user** directory.

maxage	= 8
maxexpired	= 1
minother	= 2
minlen	= 8
maxrepeats	= 2
loginretries	= 3
histexpire	= 52
histsize	= 20

To change the defaults, use the following commands:

```
type oem_setup_env
```

```
chsec -f /etc/security/user -s default -a maxage=8 -a maxexpired=1 -a minother=2  
-a minlen=8 -a maxrepeats=2 -a loginretries=3 -a histexpire=52 -a histsize=20
```

When the prime administrator (**padmin**) creates a new user, the user attributes must be specified explicitly for that user. For example, to create a user with name *davis*, the **padmin** would use the following command:

```
mkuser maxage=8 maxexpired=1 minother=2 minlen=8 maxrepeats=2 loginretries=3  
histexpire=52 histsize=20 davis
```

The **padmin** should also stop the following daemons and then reboot:

- To remove **writesrv** and **ctrmc** from the **/etc/inittab** file:

```
sshd: stopsrc -s sshd
```

- To prevent the daemon from starting at boot time, remove the **/etc/rc.d/rc2.d/Ksshd** and **/etc/rc.d/rc2.d/Ssshd** files. After reboot stop the RSCT daemons:

```
stopsrc -g rsct_rm stopsrc -g rsct
```

All users, regardless of their roles, are to be considered as administrative users.

The system administrator can run all of the commands except those in the following list that are limited to prime admin (**padmin**):

- **chdate**
- **chuser**
- **cleargcl**
- **de_access**
- **diagmenu**
- **invscout**
- **loginmsg**
- **lsfailedlogin**
- **lsgcl**
- **mirrorios**
- **mkuser**
- **motd**
- **oem_platform_level**
- **oem_setup_env**
- **redefvg**
- **rmuser**
- **shutdown**
- **unmirrorios**

X Server:

X Server should not be allowed to bind to port 6000.

To prevent the X Server from binding (listening) on port 6000, edit the **xserverrc** file in the **/usr/lpp/X11/defaults** directory, and modify the **EXTENSIONS** variable to **EXTENSIONS="\$EXTENSIONS -x abx -x dbe -x GLX -secIP"**.

Login control

You can change the login screen defaults for security reasons after a system installation.

Potential hackers can get valuable information from the default AIX login screen, such as the host name and the version of the operating system. This information would allow them to determine which exploitation methods to attempt. For security reasons, you may want to change the login screen defaults as soon as possible after a system installation.

The KDE and GNOME desktops share some of the same security issues. For more information about KDE and GNOME, refer to the *Installation and migration*.

For information about users, groups, and passwords, see “Users, groups, and passwords” on page 45.

Setting up login controls:

You can set up login controls in the **/etc/security/login.cfg** file.

To make it harder to attack a system with password guessing, set up login controls in the `/etc/security/login.cfg` file as follows:

Table 2. Attributes and Recommended Values for Login Control.

Attribute	Applies to PtYs (Network)	Applies to TTYs	Recommended Value	Comments
sak_enabled	Y	Y	false	The Secure Attention key is rarely needed. See "Using the Secure Attention Key" on page 5.
logintimes	N	Y		Specify allowed login times here.
logindisable	N	Y	4	Disable login on this terminal after 4 consecutive failed attempts.
logininterval	N	Y	60	Terminal will be disabled when the specified invalid attempts have been made within 60 seconds.
loginreenable	N	Y	30	Re-enable the terminal after it was automatically disabled after 30 minutes.
logindelay	Y	Y	5	The time in seconds between login prompts. This will be multiplied with the number of failed attempts; for example, 5,10,15,20 seconds when 5 is the initial value.

These port restrictions work mostly on attached serial terminals, not on pseudo-terminals used by network logins. You can specify explicit terminals in this file, for example:

```
/dev/tty0:
    logintimes = 0600-2200
    logindisable = 5
    logininterval = 80
    loginreenable = 20
```

Changing the welcome message on the login screen:

To prevent displaying certain information on login screens, edit the `herald` parameter in the `/etc/security/login.cfg` file.

The default `herald` contains the welcome message that displays with your login prompt. To change this parameter, you can either use the `chsec` command or edit the file directly.

The following example uses the `chsec` command to change the default `herald` parameter:

```
# chsec -f /etc/security/login.cfg -a default -herald
"Unauthorized use of this system is prohibited.\n\nlogin: "
```

For more information about the `chsec` command, see the *AIX Version 6.1 Commands Reference, Volume 1*.

To edit the file directly, open the `/etc/security/login.cfg` file and update the `herald` parameter as follows:

```
default:
herald ="Unauthorized use of this system is prohibited\n\nlogin:"
sak_enable = false
logintimes =
logindisable = 0
logininterval = 0
loginreenable = 0
logindelay = 0
```

Note: To make the system more secure, set the *logindisable* and *logindelay* variables to a number greater than 0 (# > 0).

Changing the login screen for the common desktop environment:

This security issue also affects the Common Desktop Environment (CDE) users. The CDE login screen also displays, by default, the host name and the operating system version. To prevent this information from being displayed, edit the */usr/dt/config/\$LANG/Xresources* file, where **\$LANG** refers to the local language installed on your machine.

In our example, assuming that **\$LANG** is set to **C**, copy this file into the */etc/dt/config/C/Xresources* directory. Next, open the */usr/dt/config/C/Xresources* file and edit it to remove welcome messages that include the host name and operating system version.

For more information about CDE security issues, see “Managing X11 and CDE concerns” on page 38.

Disabling the display of the user name and changing the password prompt:

In a secure environment, it might be necessary to hide the display of the login user name or to provide a custom password prompt that differs from the default.

The default message behavior for the login and password prompt is shown below:

```
login: foo
foo's Password:
```

To disable the display of the user name from prompts and system error messages, edit the *usernameecho* parameter in the */etc/security/login.cfg* file. The default value for *usernameecho* is true which results in the user name being displayed. To change this parameter, you can either use the **chsec** command or edit the file directly.

The following example uses the **chsec** command to change the default *usernameecho* parameter to false:

```
# chsec -f /etc/security/login.cfg -s default -a usernameecho=false
```

For more information about the **chsec** command, see the *AIX Version 6.1 Commands Reference, Volume 1*.

To edit the file directly, open the */etc/security/login.cfg* file and add or modify the *usernameecho* parameter as follows:

```
default:
usernameecho = false
```

Setting the *usernameecho* parameter to false will result in the user name not being displayed at the login prompt. Instead, the user name is masked out with '*' characters for system prompts and error messages as show below:

```
login:
***'s Password:
```

The password prompt may be separately modified to be a custom string by setting the *pwdprompt* parameter in the */etc/security/login.cfg* file. The default value is a string "user's Password: " where *user* is replaced with the authenticating user name.

To change this parameter, you can either use the **chsec** command or edit the file directly.

The following example uses the **chsec** command to change the default *pwdprompt* parameter to "Password: ":

```
# chsec -f /etc/security/login.cfg -s default -a pwdprompt="Password: "
```

To edit the file directly, open the `/etc/security/login.cfg` file and add or modify the `pwdprompt` parameter as follows:

```
default:  
pwdprompt = "Password: "
```

Setting the `pwdprompt` parameter to `"Password: "` will result in the specified prompt being displayed by login as well as by other applications that use the system password prompt. The prompt behavior for the login when the a custom prompt has been configured is as follows:

```
login: foo  
Password:
```

Setting up system default login parameters:

Edit the `/etc/security/login.cfg` file to set up system default login parameters.

To set up base defaults for many login parameters, such as those you might set up for a new user (number of login retries, login re-enable, and login interval), edit the `/etc/security/login.cfg` file.

Securing unattended terminals:

Use the **lock** and **xlock** commands to secure your terminal.

All systems are vulnerable if terminals are left logged in and unattended. The most serious problem occurs when a system manager leaves a terminal unattended that has been enabled with root authority. In general, users should log out any time they leave their terminals. Leaving system terminals unsecure poses a potential security hazard. To lock your terminal, use the **lock** command. If your interface is AIXwindows, use the **xlock** command.

Enforcing automatic logoff:

Enable automatic logoff to prevent an intruder from compromising the security of the system.

Another valid security concern results from users leaving their accounts unattended for a lengthy period of time. This situation allows an intruder to take control of the user's terminal, potentially compromising the security of the system.

To prevent this type of potential security hazard, you can enable automatic logoff on the system. To do this, edit the `/etc/security/.profile` file to include an automatic logoff value for *all* users, as in the following example:

```
TMOUT=600 ; TIMEOUT=600 ; export readonly TMOUT TIMEOUT
```

The number 600, in this example, is in seconds, which is equal to 10 minutes. However, this method will only work from the shell.

While the previous action allows you to enforce an automatic logoff policy for all users, system users can bypass some restrictions by editing their individual `.profile` files. To completely implement an automatic logoff policy, take authoritative action by providing users with appropriate `.profile` files, preventing write-access rights to these files.

Stack Execution Disable protection

Keeping computer systems secure forms an important aspect of an On Demand business. In today's world of highly networked environments, it has become an extreme challenge to ward off attacks from a variety of sources.

There is increasing likelihood of computer systems falling prey to sophisticated attacks, resulting in disruption to the daily operations of businesses and government agencies. While no security measure can

provide foolproof protection against attacks, you should deploy multiple security mechanisms to thwart security attacks. This section covers a security mechanism that is used with AIX to thwart attacks due to buffer overflow based execution.

Security breaches occur in many forms, but one of the most common methods is to monitor the system-provided administrative tools, look for, and exploit buffer overflows. Buffer overflow attacks occur when an internal program buffer is overwritten because data was not properly validated (such as command line, environmental variable, disk or terminal I/O). Attack code is inserted into a running process through the buffer overflow, changing the execution path of the running process. The return address is overwritten and redirected to the inserted-code location. Common causes of breaches include improper or nonexistent bounds checking, or incorrect assumptions about the validity of data sources. For example, a buffer overflow can occur when a data object is large enough to hold 1 KB of data, but the program does not check the bounds of the input and hence can be made to copy more than 1 KB into that data object.

The intruder's goal is to attack a command and/or tool that provides root privileges to a regular user. Control of the program is gained with all the privileges enabled, permitting overflow of the buffers. Attacks are typically focused on a root owned UID set or programs leading to the execution of a shell, thereby gaining root-based shell access to the system.

You can prevent these attacks by blocking execution of attack code entering through the buffer overflow. Disable execution on the memory areas of a process where execution commonly does not take place (stack and heap memory areas).

SED buffer overflow protection mechanism:

AIX has enabled the stack execution disable (SED) mechanism to disable the execution of code on a stack and select data areas of a process.

By disabling the execution and then terminating, an infringing program, the attacker is prevented from gaining root user privileges through a buffer overflow attack. While this feature does not stop buffer overflows, it provides protection by disabling the execution of attacks on buffers that have been overflowed.

Beginning with the POWER4 family of processors, you can use a page-level execution enable and/or disable feature for the memory. The AIX SED mechanism uses this underlying hardware support for implementing a no-execution feature on select memory areas. Once this feature is enabled, the operating system checks and flags various files during the executable programs. It then alerts the operating system memory manager and the process managers that the SED is enabled for the process being created. The select memory areas are marked for no-execution. If any execution occurs on these marked areas, the hardware raises an exception flag and the operating system stops the corresponding process. The exception and application termination details are captured through the AIX error log events.

SED is implemented mainly through the **sedmgr** command. The **sedmgr** command permits control of the systemwide SED mode of operation as well as setting the executable file based SED flags.

SED modes and monitoring:

The stack execution disable (SED) mechanism in AIX is implemented through systemwide mode flags, as well as individual executable file-based header flags.

While systemwide flags control the systemwide operation of the SED, file level flags indicate how files should be treated in SED. The buffer overflow protection (BOP) mechanism provides for four systemwide modes of operation:

off The SED mechanism is turned off and no process is marked for SED protection.

select Only a select set of files are enabled and monitored for SED protection. The select set of files are

chosen by reviewing the SED related flags in the executable program binary headers. The executable program header enables SED related flags to request to be included in the **select** mode.

setidfiles

Permits you to enable SED, not only for the files requesting such a mechanism, but all the important **setuid** and **setgid** system files. In this mode, the operating system not only provides SED for the files with the **request** SED flag set, but also enables SED for the executable files with the following characteristics (except the files marked for *exempt* in their file headers):

- SETUID files owned by root
- SETGID files with primary group as **system** or **security**

all All executable programs loaded on the system are SED protected except for the files requesting an exemption from SED mode. Exemption related flags are part of the executable program headers.

The SED feature on AIX also provides the ability to monitor instead of stopping the process when an exception happens. This systemwide control permits a system administrator to check for breakdowns and issues in the system environment by monitoring it before the SED is deployed in the production systems.

The **sedmgr** command provides an option that permits you to enable SED to monitor files instead of stopping the processes when exceptions occur. The system administrator can evaluate whether an executable program is doing any legitimate stack execution. This setting works in conjunction with the systemwide mode set using the **-c** option. When the **monitor** mode is turned on, the system permits the process to continue operating even if an SED-related exception occurs. Instead of stopping the process, the operating system logs the exception in the AIX error log. If SED monitoring is off, the operating system stops any process that violates and raises an exception per SED facility.

Any changes to the SED mode systemwide flags requires that you restart the system for the changes to take effect. All of these types of events are audited.

SED flags for executables:

In AIX, you can use the **sedmgr** command to flag executables from the SE mechanism.

Linker has been enhanced to support two new SED related flags to enable **select** and **exempt** options in the executable's headers. The **select** flag permits an executable to request and be part of SED protection during the **select** mode of systemwide SED operation, whereas the **exempt** flag permits an executable to request for an exemption from the SED mechanism. These executables are not enabled for execution disable on any of the process memory areas.

The exemption flag permits a system administrator to monitor the SED mechanism, and evaluate the situation. The system administrator can enable execution on stack and data areas as necessary for the application, with the associated risks understood.

The following table shows how the systemwide settings and file settings affect the SED mode of operation:

Table 3. Systemwide settings and file settings affecting the SED mode

System SED mode	Executable file SED flags			Setuid-root or setgid-system/ security files
	request	exempt	system	
off	–	–	–	–
select	enabled	–	–	–
setgidfiles	enabled	–	–	enabled
all	enabled	–	enabled	enabled

SED issues and considerations:

By default, AIX SED is shipped in **select** mode. A number of **setuid** and **setgid** programs are **select**-enabled for SED and operate in protected mode by default.

SED enablement might cause older binary files to break if they are not capable of handling the no-execution feature on the stack heap areas. These applications must run on stack data areas. The system administrator can evaluate the situation and flag the file for an exemption using the **bopmgr** command. AIX Java™ 1.3.1 and AIX Java 1.4.2 have Just-In-Time (JIT) compilers that dynamically generate and run native object code while running Java applications (the Java Virtual Machine decides which code to compile based on the execution profile of the application). This object code is stored in data buffers allocated by the JIT. Consequently, if AIX is configured to run in the SED **ALL** mode, the system administrator must set the Java binary file's exemption flag.

When SED-related flags in an executable file are changed, they apply only to a future load and execution of the file. This change does not apply to currently operating processes based on this file. The SED facility controls and monitors both 32- and 64-bit executable programs for the systemwide and file-level settings. The SED facility is available only when the AIX operating system is used with the 64-bit kernel.

Related information

sedmgr command

AIX Error-Logging Facility

Managing X11 and CDE concerns

There are potential security vulnerabilities involved with the X11 X server and the Common Desktop Environment (CDE).

Removing the /etc/rc.dt file:

Remove the **/etc/rc.dt** file on systems that require a high level of security.

Although running the CDE interface is convenient for users, security issues are associated with it. For this reason, do not run CDE on servers that require a high level of security. The best solution is to avoid installing CDE (dt) file sets. If you have installed these file sets on your system, consider uninstalling them, especially the **/etc/rc.dt** script, which starts CDE.

For more information about CDE, see the *Operating system and device management*.

Preventing unauthorized monitoring of remote X server:

An important security issue associated with the X11 server is unauthorized silent monitoring of a remote server.

The **xwd** and **xwud** commands can be used to monitor X server activity because they have the ability to capture keystrokes, which can expose passwords and other sensitive data. To solve this problem, remove these executable files unless they are necessary under your configuration, or, as an alternative, change access to these commands to be root only.

The **xwd** and **xwud** commands are located in the **X11.apps.clients** fileset.

If you do need to retain the **xwd** and **xwud** commands, consider using OpenSSH or MIT Magic Cookies. These third-party applications help prevent the risks that are created by running the **xwd** and **xwud** commands.

For more information about OpenSSH and MIT Magic Cookies, refer to each application's respective documentation.

Enabling and disabling access control:

The X server permits remote hosts to use the **xhost +** command to connect to your system.

Ensure that you specify a host name with the **xhost +** command, because it disables access control for the X server. This permits you to grant access to specific hosts, which eases monitoring for potential attacks to the X server. To grant access to a specific host, run the **xhost** command as follows:

```
# xhost + hostname
```

If you do not specify a host name, access will be granted to all hosts.

For more information about the **xhost** command, see the *AIX Version 6.1 Commands Reference*

Disabling user permissions to run the xhost command:

You can prevent the unauthorized execution of the **xhost** command by using the **chmod** command.

Another way to ensure that the **xhost** command is being used appropriately is to restrict execution of this command to root-user authority only. To do this, use the **chmod** command to change the permissions of **/usr/bin/X11/xhost** to 744, as follows:

```
chmod 744/usr/bin/X11/xhost
```

List of setuid/setgid programs

There are various setuid/setgid programs on an AIX system. You can remove these privileges on commands that do not need to be available to regular users.

The following programs are included in a normal AIX install. In a CC-configured AIX system, this list is pruned and includes fewer programs.

- **/opt/IBMinvscout/bin/invscoutClient_VPD_Survey**
- **/opt/IBMinvscout/bin/invscoutClient_PartitionID**
- **/usr/lpp/diagnostics/bin/diagsetrto**
- **/usr/lpp/diagnostics/bin/Dctrl**
- **/usr/lpp/diagnostics/bin/diagTasksWebSM**
- **/usr/lpp/diagnostics/bin/diagela**
- **/usr/lpp/diagnostics/bin/diagela_exec**
- **/usr/lpp/diagnostics/bin/diagrpt**
- **/usr/lpp/diagnostics/bin/diagrto**
- **/usr/lpp/diagnostics/bin/diaggetrto**
- **/usr/lpp/diagnostics/bin/update_manage_flash**
- **/usr/lpp/diagnostics/bin/utape**
- **/usr/lpp/diagnostics/bin/uspchrp**
- **/usr/lpp/diagnostics/bin/update_flash**
- **/usr/lpp/diagnostics/bin/uesensor**
- **/usr/lpp/diagnostics/bin/usysident**
- **/usr/lpp/diagnostics/bin/usysfault**

- /usr/lpp/X11/bin/xlock
- /usr/lpp/X11/bin/aixterm
- /usr/lpp/X11/bin/xterm
- /usr/lpp/X11/bin/msmitpasswd
- /usr/lib/boot/tftp
- /usr/lib/lpd/digest
- /usr/lib/lpd/rembak
- /usr/lib/lpd/pio/etc/piodmgrsu
- /usr/lib/lpd/pio/etc/piomkpq
- /usr/lib/lpd/pio/etc/pioout
- /usr/lib/mh/slocal
- /usr/lib/perf/libperfstat_updt_dictionary
- /usr/lib/sa/sadc
- /usr/lib/semutil
- /usr/lib/trcload
- /usr/sbin/allocp
- /usr/sbin/audit
- /usr/sbin/auditbin
- /usr/sbin/auditcat
- /usr/sbin/auditconv
- /usr/sbin/auditmerge
- /usr/sbin/auditpr
- /usr/sbin/auditselect
- /usr/sbin/auditstream
- /usr/sbin/backbyinode
- /usr/sbin/cfgmgr
- /usr/sbin/chcod
- /usr/sbin/chcons
- /usr/sbin/chdev
- /usr/sbin/chpath
- /usr/sbin/chtcb
- /usr/sbin/cron
- /usr/sbin/acct/accton
- /usr/sbin/arp64
- /usr/sbin/arp
- /usr/sbin/devinstall
- /usr/sbin/diag_exec
- /usr/sbin/entstat
- /usr/sbin/entstat.ethchan
- /usr/sbin/entstat.scent
- /usr/sbin/diskusg
- /usr/sbin/exec_shutdown
- /usr/sbin/fdformat
- /usr/sbin/format
- /usr/sbin/fuser

- /usr/sbin/luser
- /usr/sbin/lsvg
- /usr/sbin/lsvgfs
- /usr/sbin/login
- /usr/sbin/lvaryoffvg
- /usr/sbin/lvaryonvg
- /usr/sbin/lvgenmajor
- /usr/sbin/lvgenminor
- /usr/sbin/lvrelmajor
- /usr/sbin/lvrelminor
- /usr/sbin/lsmcode
- /usr/sbin/mailq
- /usr/sbin/mkdev
- /usr/sbin/mklvcopy
- /usr/sbin/mknod
- /usr/sbin/mkpasswd
- /usr/sbin/mkpath
- /usr/sbin/mkvg
- /usr/sbin/mount
- /usr/sbin/netstat64
- /usr/sbin/mtrace
- /usr/sbin/ndp
- /usr/sbin/newaliases
- /usr/sbin/named9
- /usr/sbin/named8
- /usr/sbin/netstat
- /usr/sbin/nfsstat
- /usr/sbin/pdelay
- /usr/sbin/pdisable
- /usr/sbin/penable
- /usr/sbin/perf/diag_tool/getschedparms
- /usr/sbin/perf/diag_tool/getvmparms
- /usr/sbin/phold
- /usr/sbin/portmir
- /usr/sbin/pshare
- /usr/sbin/pstart
- /usr/sbin/putlvcb
- /usr/sbin/putlvodm
- /usr/sbin/qdaemon
- /usr/sbin/quota
- /usr/sbin/reboot
- /usr/sbin/redefinevg
- /usr/sbin/repquota
- /usr/sbin/restbyinode
- /usr/sbin/rmdev

- /usr/sbin/ping
- /usr/sbin/rmgroup
- /usr/sbin/rmpath
- /usr/sbin/rmrole
- /usr/sbin/rmuser
- /usr/sbin/rsct/bin/ctstrtcasd
- /usr/sbin/srcd
- /usr/sbin/srcmstr
- /usr/sbin/rmssock64
- /usr/sbin/sendmail_ssl
- /usr/sbin/sendmail_nonssl
- /usr/sbin/rmssock
- /usr/sbin/sliplogin
- /usr/sbin/sendmail
- /usr/sbin/rwhod
- /usr/sbin/route
- /usr/sbin/snappd
- /usr/sbin/swap
- /usr/sbin/swapoff
- /usr/sbin/swapon
- /usr/sbin/swcons
- /usr/sbin/switch.prt
- /usr/sbin/synclvodm
- /usr/sbin/tsm
- /usr/sbin/umount
- /usr/sbin/umountall
- /usr/sbin/unmount
- /usr/sbin/varyonvg
- /usr/sbin/watch
- /usr/sbin/talkd
- /usr/sbin/timedc
- /usr/sbin/uucpd
- /usr/bin/bellmail
- /usr/bin/at
- /usr/bin/capture
- /usr/bin/chcore
- /usr/bin/acctras
- /usr/bin/acctctl
- /usr/bin/chgroup
- /usr/bin/chkey
- /usr/bin/chque
- /usr/bin/chquedev
- /usr/bin/chrole
- /usr/bin/chsec
- /usr/bin/chuser

- /usr/bin/confsrc
- /usr/bin/crontab
- /usr/bin/enq
- /usr/bin/filemon
- /usr/bin/errpt
- /usr/bin/fileplace
- /usr/bin/fileplacej2
- /usr/bin/fileplacej2_64
- /usr/bin/ftp
- /usr/bin/getconf
- /usr/bin/ipcs
- /usr/bin/ipcs64
- /usr/bin/iostat
- /usr/bin/logout
- /usr/bin/lscore
- /usr/bin/lsec
- /usr/bin/mesg
- /usr/bin/mkgroup
- /usr/bin/mkque
- /usr/bin/mkquedev
- /usr/bin/mkrole
- /usr/bin/mkuser
- /usr/bin/netpmon
- /usr/bin/newgrp
- /usr/bin/pagdel
- /usr/bin/paginit
- /usr/bin/paglist
- /usr/bin/passwd
- /usr/bin/pwck
- /usr/bin/pwdadm
- /usr/bin/pwdck
- /usr/bin/rm_mlcachefile
- /usr/bin/rdist
- /usr/bin/remsh
- /usr/bin/rlogin
- /usr/bin/rexec
- /usr/bin/rcp
- /usr/bin/rmque
- /usr/bin/rmquedev
- /usr/bin/rsh
- /usr/bin/ruptime
- /usr/bin/rwho
- /usr/bin/script
- /usr/bin/setgroups
- /usr/bin/setsenv

- `/usr/bin/shell`
- `/usr/bin/su`
- `/usr/bin/sysck`
- `/usr/bin/tcbck`
- `/usr/bin/sysck_r`
- `/usr/bin/telnet`
- `/usr/bin/tftp`
- `/usr/bin/traceroute`
- `/usr/bin/tn`
- `/usr/bin/tn3270`
- `/usr/bin/usrck`
- `/usr/bin/utftp`
- `/usr/bin/vmstat`
- `/usr/bin/vmstat64`
- `/usr/bin/yppasswd`
- `/sbin/helpers/jfs2/backbyinode`
- `/sbin/helpers/jfs2/diskusg`
- `/sbin/helpers/jfs2/restbyinode`

Users, groups, and passwords

You can manage AIX users and groups.

Account ID

Each user account has a numeric ID which uniquely identifies the account. AIX grants authorization according to Account ID.

It is important to understand that accounts with the same ID are virtually the same account. When creating users and groups, the AIX **mkuser** and **mkgroup** commands always check for the target registry to make sure that the account to be created has no ID collision with existing accounts.

The system can also be configured to check all user (group) registries during account creation using the **dist_uniqid** system attribute. The **dist_uniqid** attribute of the usw stanza in the `/etc/security/login.cfg` file can be managed using the **chsec** command. To configure the system to always check for id collision against all registries, run:

```
# chsec -f /etc/security/login.cfg -s usw -a dist_uniqid=always
```

There are three valid values for the **dist_uniqid** attribute:

never This value does not check for ID collision against the non-target registries (default).

always

This value checks for ID collision against all other registries. If collision detected between the target registry and any other registry, the **mkuser** (**mkgroup**) command picks a unique ID which is not used by any registry. It only fails if the ID value is specified from the command line (for example, `mkuser id=234 foo`, and ID 234 is already taken by a user in any of the registries).

uniqbyname

This value checks for ID collision against all other registries. Collision between registries is permitted only if the account to be created has the same name as the existing account for a `mkuser id=123 foo type of command`. If the ID is not specified from the command line, the new account might not have the same ID value as an existing account with the same name in another registry. For example, `acct1` with ID 234 is a local account. When creating an LDAP account `acct1`,

mkuser -R LDAP acct1 might pick a unique ID of 235 for the LDAP account. The result is *acct1* with ID 234 on local, and *acct1* with 235 on LDAP.

Note: ID collision detection in the target registry is always enforced regardless of the **dist_uniqid** attribute.

The **uniqbyname** value works well against two registries. With more than two registries, and when ID collision already exists between two registries, the behavior of **mkuser (mkgroup)** is unspecified when creating a new account in a third registry using the colliding ID values. The new account creation might succeed or fail depending the order the registries are checked.

For example: Suppose a system is configured with three registries: local, LDAP and DCE. An *acct1* account exists in LDAP and an *acct2* account in DCE, both with ID 234. When the system administrator runs the `mkuser -R files id=234 acct1 (mkgroup -R files id=234 acct1)` command to create the local account with the **uniqbyname** value, the **mkuser (mkgroup)** command checks against the LDAP registry first, and finds that ID 234 is taken by LDAP account *acct1*. Since the account to be created has the same account name, the **mkuser (mkgroup)** command successfully creates the local account *acct1* with ID 234. If the DCE registry is checked first, the **mkuser (mkgroup)** command finds that ID 234 is taken by DCE account *acct2*, and creation of local account *acct1* fails. The check for ID collision enforces ID uniqueness between the local registry and remote registries or between remote registries. There is no guarantee of ID uniqueness between the newly created account on the remote registry and existing local users on other systems which use the same remote registry. The **mkuser (mkgroup)** command bypasses the remote registry if it is not reachable at the time the command is run.

Root account

The root account has virtually unlimited access to all programs, files, and resources on a system.

The root account is the special user in the `/etc/passwd` file with the user ID (UID) of 0 and is commonly given the user name, *root*. It is not the user name that makes the root account so special, but the UID value of 0. This means that any user that has a UID of 0 also has the same privileges as the root user. Also, the root account is always authenticated by means of the local security files.

The root account should always have a password, which should never be shared. The root account should be given a password immediately after the system is installed. Only the system administrator should know the root password. System administrators should only operate as the root user to perform system administration functions that require root privileges. For all other operations, they should return to their normal user account.

Attention: Routinely operating as the root user can result in damage to the system because the root account overrides many safeguards in the system.

Disabling direct root login:

A common attack method of potential hackers is to obtain the root password.

To avoid this type of attack, you can disable direct access to your root ID and then require your system administrators to obtain root privileges by using the **su** - command. In addition to permitting you to remove the root user as a point of attack, restricting direct root access permits you to monitor which users gained root access, as well as the time of their action. You can do this by viewing the `/var/adm/sulog` file. Another alternative is to enable system auditing, which will report this type of activity.

To disable remote login access for your root user, edit the `/etc/security/user` file. Specify False as the `rlogin` value on the entry for root.

Before you disable the remote root login, examine and plan for situations that would prevent a system administrator from logging in under a non-root user ID. For example, if a user's home file system is full,

the user would not be able to log in. If the remote root login were disabled and the user who could use the **su** - command to change to root had a full home file system, root could never take control of the system. This issue can be bypassed by system administrators creating home file systems for themselves that are larger than the average user's file system.

For more information about controlling root login, see "CAPP/EAL4+ system configuration" on page 19.

User accounts

There are several security administrative tasks for user accounts.

Recommended user attributes:

User administration consists of creating users and groups and defining their attributes.

A major attribute of users is how they are authenticated. Users are the primary agents on the system. Their attributes control their access rights, environment, how they are authenticated, as well as how, when, and where their accounts can be accessed.

Groups are collections of users who can share the same access permissions for protected resources. A group has an ID and is composed of members and administrators. The creator of the group is usually the first administrator.

Many attributes can be set for each user account, including password and login attributes. For a list of configurable attributes, refer to "Disk quota system overview" on page 70. The following attributes are recommended:

- Each user should have a user ID that is not shared with any other user. All of the security safeguards and accountability tools work only if each user has a unique ID.
- Give user names that are meaningful to the users on the system. Actual names are best, because most electronic mail systems use the user ID to label incoming mail.
- Add, change, and delete users using the Web-based System Manager or SMIT interface. Although you can perform all of these tasks from the command line, these interfaces help reduce small errors.
- Do not give an initial password to a user account until the user is ready to log in to the system. If the password field is defined as an * (asterisk) in the **/etc/passwd** file, account information is kept, but no one can log in to that account.
- Do not change the system-defined user IDs that are needed by the system to function correctly. The system-defined user IDs are listed in the **/etc/passwd** file.
- In general, do not set the *admin* parameter to *true* for any user IDs. Only the root user can change attributes for users with *admin=true* set in the **/etc/security/user** file.

The operating system supports the standard user attributes usually found in the **/etc/passwd** and **/etc/system/group** files, such as:

Authentication Information	Specifies the password
Credentials	Specifies the user identifier, principal group, and the supplementary group ID
Environment	Specifies the home or shell environment.

User and group name length limit:

You can configure and retrieve the user and group name length limit.

The user and group name length limit parameter default value is 9 characters. For AIX 5.3 and later, you can increase the user and group name length limit from 9 characters to 256 characters. Because the user and group name length limit parameter includes the terminating NULL character, the actual valid name lengths are from 8 characters to 255 characters.

The user and group name length limit is specified with the **v_max_logname** system configuration parameter for the `sys0` device. You can change or retrieve the **v_max_logname** parameter value from the kernel or ODM database. The parameter value in the kernel is the value the system uses while running. The parameter value in the ODM database is the value the system uses after the next restart.

Note: Unexpected behavior might occur if you decrease the user and group name length limit after increasing it. User and group names that you created with the larger limitation might still exist on the system.

Retrieving the user and group name length limit from the ODM database:

You can use commands or subroutines to retrieve the **v_max_logname** parameter.

You can use the **lsattr** command to retrieve the **v_max_logname** parameter in the ODM database. The **lsattr** command displays the **v_max_logname** parameter as the `max_logname` attribute.

For more information, see the **lsattr** command in *AIX Version 6.1 Commands Reference, Volume 3*.

The following example shows how to use the **lsattr** command to retrieve the `max_logname` attribute:

```
$ lsattr -El sys0
SW_dist_intr  false          Enable SW distribution of interrupts          True
autorestart  true           Automatically REBOOT system after a crash     True
boottype     disk          N/A                                           False
capacity_inc 1.00         Processor capacity increment                 False
capped       true          Partition is capped                          False
conslogin    enable        System Console Login                         False
cpuguard     enable        CPU Guard                                    True
dedicated    true          Partition is dedicated                       False
ent_capacity 4.00         Entitled processor capacity                  False
frequency    93750000     System Bus Frequency                         False
fullcore     false        Enable full CORE dump                        True
fwversion    IBM,SPH01316 Firmware version and revision levels         False
iostat       false        Continuously maintain DISK I/O history       True
keylock      normal       State of system keylock at boot time         False
max_capacity 4.00         Maximum potential processor capacity          False
max_logname  20           Maximum login name length at boot time       True
maxbuf       20           Maximum number of pages in block I/O BUFFER CACHE True
maxmbuf      0            Maximum Kbytes of real memory allowed for Mbufs True
maxpout      0            HIGH water mark for pending write I/Os per file True
maxuproc     128         Maximum number of PROCESSES allowed per user True
min_capacity 1.00         Minimum potential processor capacity          False
minpout      0            LOW water mark for pending write I/Os per file True
modelname    IBM,7044-270 Machine name                                  False
ncargs       6            ARG/ENV list size in 4K byte blocks          True
pre430core   false        Use pre-430 style CORE dump                 True
pre520tune   disable      Pre-520 tuning compatibility mode           True
realmem      3145728     Amount of usable physical memory in Kbytes   False
rtasversion  1            Open Firmware RTAS version                  False
sec_flags    0            Security Flags                               True
sed_config   select       Stack Execution Disable (SED) Mode          True
systemid     IBM,0110B5F5 Hardware system identifier                   False
variable_weight 0        Variable processor capacity weight           False
$
```

Retrieving the user and group name length limit from the kernel:

You can use commands and subroutines to retrieve the **v_max_logname** parameter from the kernel.

Using the **getconf** command

You can use the **getconf** command with the **LOGIN_NAME_MAX** parameter to retrieve the user and group name length limit in the kernel. The **getconf** command output includes the terminating NULL character.

The following example shows how to use **getconf** command to retrieve the current user and group name limit from the kernel:

```
$ getconf LOGIN_NAME_MAX
20
$
```

Using the **sysconf** subroutine

You can use the **sysconf** subroutine with the **_SC_LOGIN_NAME_MAX** parameter to retrieve the user and group name length limit in the kernel.

The following example shows how to use the **sysconf** subroutine to retrieve the user and group name length limit from the kernel:

```
#include <unistd.h>
main()
{
    long len;

    len = sysconf(_SC_LOGIN_NAME_MAX);

    printf("The name length limit is %d\n", len);
}
```

Using the **sys_parm** subroutine

You can use the **sys_parm** subroutine with the **SYSP_V_MAX_LOGNAME** parameter to retrieve the current user name length limit in the kernel.

The following example shows how to use the **sys_parm** subroutine to retrieve the user name length limit from the kernel:

```
#include <sys/types.h>
#include <sys/var.h>
#include <errno.h>
main()
{
    int rc;
    struct vario myvar;

    rc = sys_parm (SYSP_GET, SYSP_V_MAX_LOGNAME, &myvar);

    if (!rc)
        printf("Max_login_name = %d\n", myvar.v.v_max_logname.value);
    else
        printf("sys_parm() failed rc = %d, errno = %d\n", rc, errno);
}
```

Changing the user group and name length limit in the ODM database:

You can configure the user and group name length limit value in the kernel only during the system boot phase. You can change the value in the ODM database using the **chdev** command. The change takes effect after the next system restart.

The following example shows how to use the **chdev** command to change the **v_max_logname** parameter in the ODM database:

```
$ chdev -l sys0 -a max_logname=30
sys0 changed
$
```

User account control:

User accounts have attributes that can be altered.

Each user account has a set of associated attributes. These attributes are created from default values when a user is created by using the **mkuser** command. The attributes can be altered by using the **chuser** command. The following are the user attributes that control login and are not related to password quality:

account_locked	If an account must be explicitly locked, this attribute can be set to True; the default is False.
admin	If set to True, this user can not change the password. Only the administrator can change it.
admgroups	Lists groups for which this user has administrative rights. For those groups, the user can add or delete members.
auth1	The authentication method that is used to grant the user access. Typically, it is set to SYSTEM, which will then use newer methods. Note: The auth1 attribute is deprecated and should not be used.
auth2	Method that runs after the user has been authenticated by whatever was specified in auth1 . It cannot block access to the system. Typically, it is set to NONE. Note: The auth2 attribute is deprecated and should not be used.
daemon	This boolean parameter specifies whether the user is allowed to start daemons or subsystems with the startsrc command. It also restricts the use of the cron and at facilities.
login	Specifies whether this user is allowed to log in. A successful login resets the unsuccessful_login_count attribute to a value of 0 (from the loginsuccess subroutine).
logintimes	Restricts when a user can log in. For example, a user might be restricted to accessing the system only during normal business hours.
registry	Specifies the user registry. It can be used to tell the system about alternate registries for user information, such as NIS, LDAP, or Kerberos.
rlogin	Specifies whether this user is allowed to log in by using rlogin or telnet .
su	Specifies whether other users can switch to this ID with the su command.
sugroups	Specifies which groups are allowed to switch to this user ID.
ttys	Limits certain accounts to physically secure areas.
expires	Manages student or guest accounts; also can be used to turn off accounts temporarily.
loginretries	Specifies the maximum number of consecutive failed login attempts before the user ID is locked by the system. The failed attempts are recorded in the /etc/security/lastlog file.
umask	Specifies the initial umask for the user.
rcmds	Specifies whether the user account can be accessed with the rsh or exec commands. A value of allow indicates that the account may be accessed by rsh and rexec . A value of deny indicates no account access by rsh and rexec commands. A value of hostlogincontrol indicates that the account access is controlled by hostallowedlogin and hostsdeniedlogin attributes.
hostallowedlogin	Specifies the hosts which permit the user to login. This attribute is intended to be used in a networked environment where user attributes are shared by multiple hosts.
hostsdeniedlogin	Specifies the hosts which do not permit the user to login. This attribute is intended to be used in a networked environment where user attributes are shared by multiple hosts.
maxulogs	Specifies the maximum number of logins per user. If the user has reached the maximum number of allowed logins, login will be denied.

The complete set of user attributes is defined in the **/etc/security/user**, **/etc/security/limits**, **/etc/security/audit/config** and **/etc/security/lastlog** files. The default for user creation with the **mkuser** command is specified in the **/usr/lib/security/mkuser.default** file. Only options that override the general defaults in the default stanzas of the **/etc/security/user** and **/etc/security/limits** files, as well as audit

classes, must be specified in the **mkuser.default** file. Several of these attributes control how a user can log in, and they can be configured to lock the user account (prevent further logins) automatically under specified conditions.

After the user account has been locked by the system due to the number of unsuccessful login attempts, the user is not able to log in until the system administrator resets the user **unsuccessful_login_count** attribute in the **/etc/security/lastlog** file to be less than the value of login retries. This can be done using the following **chsec** command, as follows:

```
chsec -f /etc/security/lastlog -s username -a
unsuccessful_login_count=0
```

The defaults can be changed by using the **chsec** command to edit the default stanza in the appropriate security file, such as the **/etc/security/user** or **/etc/security/limits** files. Many of the defaults are defined to be the standard behavior. To explicitly specify attributes that are set every time that a new user is created, change the *user* entry in **/usr/lib/security/mkuser.default**.

For information on extended user password attributes, refer to “Passwords” on page 58.

Login-related commands affected by user attributes

The following table lists the attributes that control login and the affected commands.

Note: The attributes only affect the **ssh** and **scp** commands if the **UseLogin** attribute is set to yes in the **ssh** daemon configuration file on the server.

User attribute	Commands
account_locked	rexec, rsh, rcp, ssh, scp, rlogin, telnet, ftp, login
login	Only affects login from a console. The value of the login attribute does not affect remote login commands, remote shell commands, or remote copy commands rexec, rsh, rcp, ssh, scp, rlogin, telnet , and ftp).
logintimes	rexec, rsh, rcp, ssh, scp, rlogin, telnet, ftp, login
rlogin	Only affects remote login commands, certain remote shell commands, and certain remote copy commands (ssh, scp, rlogin , and telnet).
loginretries	rexec, rsh, rcp, ssh, scp, rlogin, telnet, ftp, login
/etc/nologin	rexec, rsh, rcp, ssh, scp, rlogin, telnet, ftp, login
rcmds=deny	rexec, rsh, rcp, ssh, scp
rcmds=hostlogincontrol and hostsdeniedlogin=<target_hosts>	rexec, rsh, rcp, ssh, scp, rlogin, telnet, ftp, login
ttys = !REXEC, !RSH	rexec, rsh, rcp, ssh, scp, rlogin, telnet, ftp, login
ttys = !REXEC, !RSH, /dev/pts	rexec, rsh
ttys = !REXEC, !RSH, ALL	rexec, rsh
expires	rexec, rsh, rcp, ssh, scp, rlogin, telnet, ftp, login

Note: **rsh** only disallows execution of remote commands. Remote logins are still permitted.

Login user IDs:

The operating system identifies users by their login user ID.

The login user ID allows the system to trace all user actions to their source. After a user logs in to the system but before running the initial user program, the system sets the login ID of the process to the user ID found in the user database. All subsequent processes during the login session are tagged with this ID. These tags provide a trail of all activities performed by the login user ID. The user can reset the effective user ID, real user ID, effective group ID, real group ID, and supplementary group ID during the session, but cannot change the login user ID.

Strengthening user security with Access Control Lists:

To achieve an appropriate level of security in your system, develop a consistent security policy to manage user accounts. The most commonly used security mechanism is the access control list (ACL).

For information about ACLs and developing a security policy, see “Access Control Lists” on page 106.

PATH environment variable:

The **PATH** environment variable is an important security control. It specifies the directories to be searched to find a command.

The default systemwide **PATH** value is specified in the **/etc/profile** file, and each user normally has a **PATH** value in the user’s **\$HOME/.profile** file. The **PATH** value in the **.profile** file either overrides the systemwide **PATH** value or adds extra directories to it.

Unauthorized changes to the **PATH** environment variable can enable a user on the system to “spoof” other users (including root users). *Spoofing* programs (also called *Trojan horse* programs) replace system commands and then capture information meant for that command, such as user passwords.

For example, suppose a user changes the **PATH** value so that the system searches the **/tmp** directory first when a command is run. Then the user places in the **/tmp** directory a program called **su** that asks for the root password just like the **su** command. Then the **/tmp/su** program mails the root password to the user and calls the real **su** command before exiting. In this scenario, any root user who used the **su** command would reveal the root password and not even be aware of it.

To prevent any problems with the **PATH** environment variable for system administrators and users, do the following:

- When in doubt, specify full path names. If a full path name is specified, the **PATH** environment variable is ignored.
- Never put the current directory (specified by **.** (period)) in the **PATH** value specified for the root user. Never allow the current directory to be specified in **/etc/profile**.
- The root user should have its own **PATH** specification in his private **.profile** file. Typically, the specification in **/etc/profile** lists the minimal standard for all users, whereas the root user might need more or fewer directories than the default.
- Warn other users not to change their **.profile** files without consulting the system administrator. Otherwise, an unsuspecting user could make changes that allow unintended access. A user **.profile** file should have permissions set to 740.
- System administrators should not use the **su** command to gain root privilege from a user session, because the user’s **PATH** value specified in the **.profile** file is in effect. Users can set their own **.profile** files. System administrators should log in to the user’s machine as root user or preferably, using their own ID and then use the following command:

```
/usr/bin/su - root
```

This ensures that the root environment is used during the session. If a system administrator does operate as root in another user session, the system administrator should specify full path names throughout the session.

- Protect the input field separator (**IFS**) environment variable from being changed in the **/etc/profile** file. The **IFS** environment variable in the **.profile** file can be used to alter the **PATH** value.

Anonymous FTP with a secure user account setup

You can set up anonymous FTP with a secure user account.

Things to Consider

The information in this how-to scenario was tested using specific versions of AIX. The results you obtain might vary significantly depending on your version and level of AIX.

This scenario sets up an anonymous FTP with a secure user account, using the command line interface and a script.

Note: This scenario cannot be used on a system with the Controlled Access Protection Profile (CAPP) with Evaluation Assurance Level 4+ (EAL4+) feature.

1. Verify that the **bos.net.tcp.client** fileset is installed on your system, by typing the following command:

```
lslpp -L | grep bos.net.tcp.client
```

If you receive no output, the fileset is not installed. For instructions on how to install it, see the *Installation and migration*.

2. Verify that you have at least 8 MB of free space available in the system's **/home** directory, by typing the following command:

```
df -k /home
```

The script in step 4 requires at least 8 MB free space in the **/home** directory to install the required files and directories. If you need to increase the amount of available space, see the *Operating system and device management*.

3. With root authority, change to the **/usr/samples/tcpip** directory. For example:

```
cd /usr/samples/tcpip
```

4. To set up the account, run the following script:

```
./anon.ftp
```

5. When prompted with Are you sure you want to modify **/home/ftp?**, type **yes**. Output similar to the following displays:

```
Added user anonymous.
Made /home/ftp/bin directory.
Made /home/ftp/etc directory.
Made /home/ftp/pub directory.
Made /home/ftp/lib directory.
Made /home/ftp/dev/null entry.
Made /home/ftp/usr/lpp/msg/en_US directory.
```

6. Change to the **/home/ftp** directory. For example:

```
cd /home/ftp
```

7. Create a **home** subdirectory, by typing:

```
mkdir home
```

8. Change the permissions of the **/home/ftp/home** directory to **drwxr-xr-x**, by typing:

```
chmod 755 home
```

9. Change to the **/home/ftp/etc** directory, by typing:

```
cd /home/ftp/etc
```

10. Create the **objrepos** subdirectory, by typing:

```
mkdir objrepos
```

11. Change the permissions of the **/home/ftp/etc/objrepos** directory to **drwxrwxr-x**, by typing:

```
chmod 775 objrepos
```

12. Change the owner and group of the **/home/ftp/etc/objrepos** directory to the root user and the system group, by typing:

```
chown root:system objrepos
```

13. Create a **security** subdirectory, by typing

```
mkdir security
```

14. Change the permissions of the **/home/ftp/etc/security** directory to **drwxr-x---**, by typing:

```
chmod 750 security
```

15. Change the owner and group of the **/home/ftp/etc/security** directory to the root user and the security group, by typing:

```
chown root:security security
```

16. Change to the **/home/ftp/etc/security** directory, by typing:

```
cd security
```

17. Add a user by typing the following SMIT fast path:

```
smit mkuser
```

In this scenario, we are adding a user named test.

18. In the SMIT fields, enter the following values:

User NAME	[test]
ADMINISTRATIVE USER?	true
Primary GROUP	[staff]
Group SET	[staff]
Another user can SU TO USER?	true
HOME directory	[/home/test]

After you enter your changes, press Enter to create the user. After the SMIT process completes, exit SMIT.

19. Create a password for this user with the following command:

```
passwd test
```

When prompted, enter the desired password. You must enter the new password a second time for confirmation.

20. Change to the **/home/ftp/etc** directory, by typing

```
cd /home/ftp/etc
```

21. Copy the **/etc/passwd** file to the **/home/ftp/etc/passwd** file, using the following command:

```
cp /etc/passwd /home/ftp/etc/passwd
```

22. Using your favorite editor, edit the **/home/ftp/etc/passwd** file. For example:

```
vi passwd
```

23. Remove all lines from the copied content except those for the root, ftp, and test users. After your edit, the content should look similar to the following:

```
root!:0:0:0:/:bin/ksh
ftp*:226:1:/:home/ftp:/usr/bin/ksh
test!:228:1:/:home/test:/usr/bin/ksh
```

24. Save your changes and exit the editor.

25. Change the permissions of the **/home/ftp/etc/passwd** file to **-rw-r--r--**, by typing:

```
chmod 644 passwd
```

26. Change the owner and group of the **/home/ftp/etc/passwd** file to the root user and the security group, by typing:

```
chown root:security passwd
```

27. Copy the contents of the **/etc/security/passwd** file to the **/home/ftp/etc/security/passwd** file, using the following command:

- ```
cp /etc/security/passwd /home/ftp/etc/security/passwd
```
28. Using your favorite editor, edit the **/home/ftp/etc/security/passwd** file. For example:
 

```
vi ./security/passwd
```
  29. Remove all stanzas from the copied content except the stanza for the test user.
  30. Remove the `flags = ADMCHG` line from the test user stanza. After your edits, the content should look similar to the following:
 

```
test:
 password = 2HaAYgpDZX3Tw
 lastupdate = 990633278
```
  31. Save your changes and exit the editor.
  32. Change the permissions of the **/home/ftp/etc/security/passwd** file to `-rw-----`, by typing:
 

```
chmod 600 ./security/passwd
```
  33. Change the owner and group of the **/home/ftp/etc/security/passwd** file to the root user and the security group, by typing:
 

```
chown root:security ./security/passwd
```
  34. Using your favorite editor, edit the **/home/ftp/etc/group** file. For example:
 

```
vi group
```
  35. Add the following lines to the file:
 

```
system*:0:
staff*:1:test
```
  36. Save your changes and exit the editor.
  37. Change the permissions of the **/home/ftp/etc/group** file to `-rw-r--r--`, by typing:
 

```
chmod 644 group
```
  38. Change the owner and group of the **/home/ftp/etc/group** file to the root user and the security group, by typing:
 

```
chown root:security group
```
  39. Using your favorite editor, edit the **/home/ftp/etc/security/group** file. For example:
 

```
vi ./security/group
```
  40. Add the following lines to the file:
 

```
system:
 admin = true
staff
 admin = false
```
  41. Save your changes and exit the editor.
  42. Change the permissions of the **/home/ftp/etc/security/group** file to `-rw-r-----`, by typing:
 

```
chmod 640 ./security/group
```
  43. Change the owner and group of the **/home/ftp/etc/security/group** file to the root user and the security, by typing:
 

```
chown root:security ./security/group
```
  44. Use the following commands to copy the appropriate content into the **/home/ftp/etc/objrepos** directory:
 

```
cp /etc/objrepos/CuAt ./objrepos
cp /etc/objrepos/CuAt.vc ./objrepos
cp /etc/objrepos/CuDep ./objrepos
cp /etc/objrepos/CuDv ./objrepos
cp /etc/objrepos/CuDvDr ./objrepos
cp /etc/objrepos/CuVPD ./objrepos
cp /etc/objrepos/Pd* ./objrepos
```
  45. Change to the **/home/ftp/home** directory, by typing:
 

```
cd ../home
```
  46. Make a new home directory for your user, by typing:

```
mkdir test
```

This will be the home directory for the new ftp user.

47. Change the owner and group of the **/home/ftp/home/test** directory to the test user and the staff group, by typing:

```
chown test:staff test
```

48. Change the permissions of the **/home/ftp/home/test** file to **-rwx-----**, by typing:

```
chmod 700 test
```

At this point, you have ftp sublogin set up on your machine. You can test this with the following procedure:

1. Using ftp, connect to the host on which you created the test user. For example:

```
ftp MyHost
```

2. Log in as anonymous. When prompted for a password, press Enter.
3. Switch to the newly created test user, by using the following command:

```
user test
```

When prompted for a password, use the password you created in step 19 on page 54

4. Use the pwd command to verify the user's home directory exists. For example:

```
ftp> pwd
/home/test
```

The output shows **/home/test** as an **ftp** subdirectory. The full path name on the host is actually **/home/ftp/home/test**.

For more information:

- "TCP/IP Security" in *Security*
- "**ftp Command**" in *AIX Version 6.1 Commands Reference*

## System special user accounts

AIX provides a default set of system special user accounts that prevents the root and system accounts from owning all operating system files and file systems.

**Attention:** Use caution when removing a system special user account. You can disable a specific account by inserting an asterisk (\*) at the beginning of its corresponding line of the **/etc/security/passwd** file. However, be careful not to disable the root user account. If you remove system special user accounts or disable the root account, the operating system will not function.

The following accounts are predefined in the operating system:

**adm** The adm user account owns the following basic system functions:

- Diagnostics, the tools for which are stored in the **/usr/sbin/perf/diag\_tool** directory.
- Accounting, the tools for which are stored in the following directories:
  - **/usr/sbin/acct**
  - **/usr/lib/acct**
  - **/var/adm**
  - **/var/adm/acct/fiscal**
  - **/var/adm/acct/nite**
  - **/var/adm/acct/sum**

**bin** The bin user account typically owns the executable files for most user commands. This account's primary purpose is to help distribute the ownership of important system directories and files so that everything is not owned solely by the root and sys user accounts.



## daemon

The daemon user account exists only to own and run system server processes and their associated files. This account guarantees that such processes run with the appropriate file access permissions.

## nobody

The nobody user account is used by the Network File System (NFS) to enable remote printing. This account exists so that a program can permit temporary root access to root users. For example, before enabling Secure RPC or Secure NFS, check the **/etc/public** key on the master NIS server to find a user who has not been assigned a public key and a secret key. As root user, you can create an entry in the database for each unassigned user by entering:

```
newkey -u username
```

Or, you can create an entry in the database for the nobody user account, and then any user can run the **chkey** program to create their own entries in the database without logging in as root.

**root** The root user account, UID 0, through which you can perform system maintenance tasks and troubleshoot system problems.

**sys** The sys user owns the default mounting point for the Distributed File Service (DFS™) cache, which must exist before you can install or configure DFS on a client. The **/usr/sys** directory can also store installation images.

## system

System group is a system-defined group for system administrators. Users of the system group have the privilege to perform some system maintenance tasks without requiring root authority.

### **Removing unnecessary default user accounts:**

During installation of the operating system, a number of default user and group IDs are created. Depending on the applications you are running on your system and where your system is located in the network, some of these user and group IDs can become security weaknesses, vulnerable to exploitation. If these users and group IDs are not needed, you can remove them to minimize security risks associated with them.

The following table lists the most common default user IDs that you might be able to remove:

*Table 4. Common default user IDs that you might be able to remove.*

| User ID     | Description                                                                                                                                                                                                                                                                                          |
|-------------|------------------------------------------------------------------------------------------------------------------------------------------------------------------------------------------------------------------------------------------------------------------------------------------------------|
| uucp, nuucp | Owner of hidden files used by uucp protocol. The uucp user account is used for the UNIX-to-UNIX Copy Program, which is a group of commands, programs, and files, present on most AIX systems, that allows the user to communicate with another AIX system over a dedicated line or a telephone line. |
| lpd         | Owner of files used by printing subsystem                                                                                                                                                                                                                                                            |
| guest       | Allows access to users who do not have access to accounts                                                                                                                                                                                                                                            |

The following table lists common group IDs that might not be needed:

*Table 5. Common group IDs that might not be needed.*

| Group ID | Description                                |
|----------|--------------------------------------------|
| uucp     | Group to which uucp and nuucp users belong |
| printq   | Group to which lpd user belongs            |

Analyze your system to determine which IDs are indeed not needed. There might also be additional user and group IDs that you might not need. Before your system goes into production, perform a thorough evaluation of available IDs.

### **Accounts created by security components:**

When security components such as LDAP and OpenSSH are installed or configured, user and group accounts are created.

The user and group accounts created include:

- **Internet Protocol (IP) Security:** IP Security adds the user *ipsec* and the group *ipsec* during its installation. These IDs are used by the key management service. Note that the group ID in `/usr/lpp/group.id.keymgt` cannot be customized before the installation.
- **Kerberos and Public Key Infrastructure (PKI):** These components do not create any new user or group accounts.
- **LDAP:** When the LDAP client or server is installed, the *ldap* user account is created. The user ID of *ldap* is not fixed. When the LDAP server is installed, it automatically installs DB2®. The DB2 installation creates the group account *dbsysadm*. The default group ID of *dbsysadm* is 400. During the configuration of the LDAP server, the `mksecldap` command creates the *ldapdb2* user account.
- **OpenSSH:** During the installation of OpenSSH, the user *sshd* and group *sshd* are added to the system. The corresponding user and group IDs must not be changed. The privilege separation feature in SSH requires IDs.

## **Passwords**

Guessing passwords is one of the most common attack methods that a system experiences. Therefore, controlling and monitoring your password-restriction policy is essential.

AIX provides mechanisms to help you enforce a stronger password policy, such as establishing values for the following:

- Minimum and maximum number of weeks that can elapse before and after a password can be changed
- Minimum length of a password
- Minimum number of alphabetic characters that can be used when selecting a password

### **Establishing good passwords:**

Good passwords are effective first lines of defense against unauthorized entry into a system.

Passwords are effective if they are:

- A mixture of both uppercase and lowercase letters
- A combination of alphabetic, numeric, or punctuation characters. Also, they may have special characters such as `~!@#$$%^&*()-_+=[]{}|\;:'",.<>?/<space>`
- Are not written down anywhere
- Are at least 7 to a maximum of `PW_PASSLEN` characters in length, if using the `/etc/security/passwd` file (authentication implementations that use registries, such as LDAP, can have passwords that exceed this maximum length)
- Are not real words that can be found in any dictionary
- Are not patterns of letters on the keyboard, like *qwerty*
- Are not real words or known patterns spelled backwards
- Do not contain any personal information about yourself, family, or friends
- Do not follow the same pattern as a previous password
- Can be typed relatively quickly so someone nearby cannot determine your password

In addition to these mechanisms, you can further enforce stricter rules by restricting passwords so that they cannot include standard UNIX words, which can be guessed. This feature uses the dictionlist, which requires that you first have the **bos.data** and **bos.txt** file sets installed.

To implement the previously defined dictionlist, edit the following line in the **/etc/security/users** file:

```
dictionlist = /usr/share/dict/words
```

The **/usr/share/dict/words** file uses the dictionlist to prevent standard UNIX words from being used as passwords.

### **Using the /etc/passwd file:**

Traditionally, the **/etc/passwd** file is used to keep track of every registered user that has access to a system.

The **/etc/passwd** file is a colon-separated file that contains the following information:

- User name
- Encrypted password
- User ID number (UID)
- User's group ID number (GID)
- Full name of the user (GECOS)
- User home directory
- Login shell

The following is an example of an **/etc/passwd** file:

```
root!:0:0:0:/:usr/bin/ksh
daemon!:1:1:1:/:etc:
bin!:2:2:2:/:bin:
sys!:3:3:3:/:usr/sys:
adm!:4:4:4:/:var/adm:
uucp!:5:5:5:/:usr/lib/uucp:
guest!:100:100:0:/:home/guest:
nobody!:4294967294:4294967294:0:/:
lpd!:9:4294967294:0:/:
lp:*:11:11:0:/:var/spool/lp:/bin/false
invscout*:200:1:0:/:var/adm/invscout:/usr/bin/ksh
nuucp*:6:5:uucp login user:/var/spool/uucppublic:/usr/sbin/uucp/uucico
paul!:201:1:0:/:home/paul:/usr/bin/ksh
jdoe*:202:1:John Doe:/home/jdoe:/usr/bin/ksh
```

AIX does not store encrypted passwords in the **/etc/password** file in the way that UNIX systems do, but in the <sup>1</sup> file by default, which is only readable by the root user. The password filed in **/etc/passwd** is used by AIX to signify if there is a password or whether the account is blocked.

The **/etc/passwd** file is owned by the root user and must be readable by all the users, but only the root user has writable permissions, which is shown as **-rw-r--r--**. If a user ID has a password, then the password field will have an **!** (exclamation point). If the user ID does not have a password, then the password field will have an **\*** (asterisk). The encrypted passwords are stored in the **/etc/security/passwd** file. The following example contains the last four entries in the **/etc/security/passwd** file based on the entries from the **/etc/passwd** file shown previously.

```
guest:
 password = *

nobody:
 password = *
```

---

1. /etc/security/password

```
lpd:
 password = *

paul:
 password = eacVScDKri4s6
 lastupdate = 1026394230
 flags = ADMCHG
```

The user ID `jdoue` does not have an entry in the `/etc/security/passwd` file because it does not have a password set in the `/etc/passwd` file.

The consistency of the `/etc/passwd` file can be checked using the `pwdck` command. The `pwdck` command verifies the correctness of the password information in the user database files by checking the definitions for all of the users or for specified users.

### ***Using the /etc/passwd file and network environments:***

In a traditional networked environment, a user must have had an account on each system to gain access to that system.

That typically meant that the user would have an entry in each of the `/etc/passwd` files on each system. However, in a distributed environment, there is no easy way to ensure that every system had the same `/etc/passwd` file. To solve this problem, several methods make the information in the `/etc/passwd` file available over the network, including Network Information System (NIS) and NIS+.

For more information about NIS and NIS+, see “Network Information Services and NIS+ security” on page 272.

### ***Hiding user names and passwords:***

To achieve a higher level of security, ensure that user IDs and passwords are not visible within the system.

The `.netrc` files contain user IDs and passwords. This file is not protected by encryption or encoding, thus its contents are clearly shown as plain text. To find these files, run the following command:

```
find `awk -F: '{print $6}' /etc/passwd` -name .netrc -ls
```

After you locate these files, delete them. A more effective way to save passwords is by setting up Kerberos. For more information about Kerberos, see “Kerberos” on page 291.

### ***Setting recommended password options:***

Proper password management can only be accomplished through user education. To provide some additional security, the operating system provides configurable password restrictions. These allow the administrator to constrain the passwords chosen by users and to force passwords to be changed regularly.

Password options and extended user attributes are located in the `/etc/security/user` file, an ASCII file that contains attribute stanzas for users. These restrictions are enforced whenever a new password is defined for a user. All password restrictions are defined per user. By keeping restrictions in the default stanza of the `/etc/security/user` file, the same restrictions are enforced on all users. To maintain password security, all passwords must be similarly protected.

Administrators can also extend the password restrictions. Using the `pwdchecks` attribute of the `/etc/security/user` file, an administrator can add new subroutines (known as *methods*) to the password restrictions code. Thus, local site policies can be added to and enforced by the operating system. For more information, see “Extending password restrictions” on page 65.

Apply password restrictions sensibly. Attempts to be too restrictive, such as limiting the password space, which makes guessing the password easier, or forcing the user to select passwords that are difficult to remember, which might then be written down, can jeopardize password security. Ultimately, password security rests with the user. Simple password restrictions, coupled with sensible guidelines and an occasional audit to verify that current passwords are unique, are the best policy.

The following table lists recommended values for some security attributes related to user passwords in the **/etc/security/user** file.

Table 6. Recommended security attribute values for user passwords.

| Attribute   | Description                                                                                                                                                                                                                 | Recommended Value            | Default Value  | Maximum Value  |
|-------------|-----------------------------------------------------------------------------------------------------------------------------------------------------------------------------------------------------------------------------|------------------------------|----------------|----------------|
| dictionlist | Verifies passwords do not include standard UNIX words.                                                                                                                                                                      | <b>/usr/share/dict/words</b> | Not applicable | Not applicable |
| histexpire  | Number of weeks before password can be reused.                                                                                                                                                                              | 26                           | 0              | 260*           |
| histsize    | Number of password iterations allowed.                                                                                                                                                                                      | 20                           | 0              | 50             |
| maxage      | Maximum number of weeks before password must be changed.                                                                                                                                                                    | 8                            | 0              | 52             |
| maxexpired  | Maximum number of weeks beyond <i>maxage</i> that an expired password can be changed by the user. (Root is exempt.)                                                                                                         | 2                            | -1             | 52             |
| maxrepeats  | Maximum number of characters that can be repeated in passwords.                                                                                                                                                             | 2                            | 8              | 8              |
| minage      | Minimum number of weeks before a password can be changed. This should not be set to a nonzero value unless administrators are always easy to reach to reset an accidentally compromised password that was recently changed. | 0                            | 0              | 52             |
| minalpha    | Minimum number of alphabetic characters required on passwords.                                                                                                                                                              | 2                            | 0              | PW_PASLEN**    |

Table 6. Recommended security attribute values for user passwords. (continued)

| Attribute   | Description                                                                                                      | Recommended Value                                                       | Default Value  | Maximum Value  |
|-------------|------------------------------------------------------------------------------------------------------------------|-------------------------------------------------------------------------|----------------|----------------|
| mindiff     | Minimum number of unique characters that passwords must contain.                                                 | 4                                                                       | 0              | PW_PASSLEN**   |
| minlen      | Minimum length of password.                                                                                      | 6 (8 for root user)                                                     | 0              | PW_PASSLEN**   |
| minother    | Minimum number of non-alphabetic characters required on passwords.                                               | 2                                                                       | 0              | PW_PASSLEN**   |
| pwdwarntime | Number of days before the system issues a warning that a password change is required.                            | 5                                                                       | Not applicable | Not applicable |
| pwdchecks   | This entry can be used to augment the <b>passwd</b> command with a custom code that checks the password quality. | For more information. see “Extending password restrictions” on page 65. | Not applicable | Not applicable |

\* A maximum of 50 passwords are retained.

\*\* PW\_PASSLEN is defined in userpw.h

For a Controlled Access Protection Profile and Evaluation Assurance Level 4+ (CAPP/EAL4+) system, use the values recommended in “User and port configuration” on page 19.

If text processing is installed on the system, the administrator can use the **/usr/share/dict/words** file as a **dictionary** dictionary file. In such a case, the administrator can set the **minother** attribute to 0. Because most words in the dictionary file do not contain characters that fall into the **minother** attribute category, setting the **minother** attribute to 1 or more eliminates the need for the vast majority of words in this dictionary file.

The minimum length of a password on the system is set by the value of the **minlen** attribute or the value of the **minalpha** attribute plus the value of the **minother** attribute, whichever is greater. The maximum length of a password is PW\_PASSLEN characters. The number of characters used when generating the stored password value is dependent on the password algorithm in use on the system. Password algorithms are defined in the **/etc/security/pwdalg.cfg** file and the default password algorithm to use can be configured through the **pwd\_algorithm** attribute in **/etc/security/login.cfg**. The value of the **minalpha** attribute plus the value of the **minother** attribute must never be greater than PW\_PASSLEN. If the value of the **minalpha** plus the value of the **minother** attribute is greater than PW\_PASSLEN, the value of the **minother** attribute is reduced to PW\_PASSLEN minus the value of the **minalpha** attribute.

If the values of both the **histexpire** attribute and the **histsize** attribute are set, the system retains the number of passwords required to satisfy both conditions, up to the system limit of 50 passwords per user. Null passwords are not retained.

You can edit the **/etc/security/user** file to include any defaults you want to use to administer user passwords. Alternatively, you can change attribute values by using the **chuser** command.

Other commands that can be used with this file are the **mkuser**, **lsuser**, and **rmuser** commands. The **mkuser** command creates an entry for each new user in the `/etc/security/user` file and initializes its attributes with the attributes defined in the `/usr/lib/security/mkuser.default` file. To display the attributes and their values, use the **lsuser** command. To remove a user, use the **rmuser** command.

### ***Support for passwords with more than 8 characters and Loadable Password Algorithm:***

Recent advancements in computer hardware makes tradition UNIX password encryption vulnerable to brute-force password guessing attacks. A cryptographically weak algorithm can lead to recovery of even strong passwords. AIX 5L introduced Loadable Password Algorithm (LPA) that supports secure password hash mechanisms. It also removes the eight-character password limitation.

#### *Traditional password crypt function:*

The standard AIX authentication mechanism uses a one-way hash function called **crypt** to authenticate users. The **crypt** function is a modified DES algorithm. It performs a one-way encryption of a fixed data array with the supplied password and a Salt.

The **crypt** function uses only the first eight characters from the password string; the user's password is truncated to eight characters. If the password contains less than eight characters, it is padded with zero bits on the right. The 56-bit DES key is derived by using the 7 bits from each character.

Salt is a two-character string (the 12 bits of the Salt is used to perturb the DES algorithm) chosen from the character set "**A-Z**", "**a-z**", "**0-9**", ".", "(period)" and "/". Salt is used to vary the hashing algorithm, so that the same clear text password can produce 4,096 possible password encryptions. A modification to the DES algorithm, swapping bits *i* and *i+24* in the DES E-Box output when bit *i* is set in the Salt, achieves this while also making DES encryption hardware useless for password guessing.

The 64-bit all-bits-zero block is encrypted 25 times with the DES key. The final output is the 12-bit salt concatenated with the encrypted 64-bit value. The resulting 76-bit value is recoded into 13 printable ASCII characters in the form of base64.

#### *Password hashing algorithms:*

Hashing algorithms such as MD5 are harder to break than the **crypt** function. This provides a strong mechanism against brute-force password guessing attacks. Since the whole password is used for generating the hash, there is no password length limitation when password hashing algorithms are used to encrypt the password.

#### *Loadable Password Algorithm (LPA):*

AIX 5L implemented a Loadable Password Algorithm (LPA) mechanism that can easily deploy new password encryption algorithms.

Each supported password encryption algorithm is implemented as a LPA load module that is loaded at runtime when the algorithm is needed. The supported LPAs and their attributes are defined in the `/etc/security/pwdalg.cfg` system configuration file.

An administrator can set up a system-wide password encryption mechanism that uses a specific LPA to encrypt the passwords. After the system-wide password mechanism is changed, AIX 5L still supports passwords that are encrypted by the previous selected password encryption mechanisms, such as the **crypt** function.

#### *Support for passwords longer than eight characters:*

All of the LPAs implemented for AIX 5L support passwords longer than eight characters. The password length limitations vary for different LPAs. The maximum password length supported by AIX 5L is 255 characters.

*LPA configuration file:*

The LPA configuration file is **/etc/security/pwdalg.cfg**. It is a stanza file that defines the attributes of the supported LPAs.

The following LPA attributes are defined in the config file:

- The path to the LPA module
- The optional flags that is passed to the LPA module at runtime

The LPA attributes defined in the configuration file can be accessed with the **getconfattr** and **setconfattr** interfaces.

The following example stanza in **/etc/security/pwdalg.cfg** defines a LPA named **ssha256**:

```
ssha256:
 lpa_module = /usr/lib/security/ssha
 lpa_options = algorithm=sha256
```

*System password algorithm:*

A system administrator can set a system-wide password algorithm by selecting an LPA as the password hashing algorithm. There can only be one active system password algorithm at a time. The system password algorithm is defined by the **pwd\_algorithm** system attribute in the **usw** stanza in the **/etc/security/login.cfg** file.

The valid values for the **pwd\_algorithm** attribute in the **/etc/security/login.cfg** file are LPA stanza names that are defined in the **/etc/security/pwdalg.cfg** file. Another valid value for the **pwd\_algorithm** attribute is **crypt**, which refers to traditional **crypt** encryption. If the **pwd\_algorithm** attribute is omitted from the config file, **crypt** is used as the default value.

The following example of the **/etc/security/login.cfg** file uses **ssha256** LPA as the system-wide password encryption algorithm.

```
... ..
usw:
 shells = /bin/sh,/bin/bsh,/bin/csh,/bin/ksh,/bin/tsh,/bin/ksh93
 maxlogins = 32767
 logintimeout = 60
 maxroles = 8
 auth_type = STD_AUTH
 pwd_algorithm = ssha256
... ..
```

The system password algorithm takes effect only for newly created passwords and changed passwords. After the migration, all subsequent new passwords or password changes use the system password algorithm. The passwords that existed before the system password algorithm is chosen, either generated by the standard **crypt** function or by other supported LPA modules, still work on the system. Therefore, mixed passwords that were generated by different LPAs can coexist on the system.

*Setting up the system password algorithm:*

A system administrator can use the **chsec** command to set up the system password algorithm or use an editor such as **vi** to manually modify the **pwd\_algorithm** attribute in the **/etc/security/login.cfg** file.



It is recommended that you use the **chsec** command to set the system password algorithm, as the **chsec** command automatically checks the definition of the specified LPA.

### Using the chsec command

Run the following command to set the **smd5** LPA as the system-wide password encryption module:

```
chsec -f /etc/security/login.cfg -s usw -a pwd_algorithm=smd5
```

When you use the **chsec** command to modify the **pwd\_algorithm** attribute, the **chsec** command checks the **/etc/security/pwdalg.cfg** file to verify the specified LPA. The **chsec** command fails if this check fails.

### Using an editor

If you use an editor to manually change the **pwd\_algorithm** attribute value in the **/etc/security/login.cfg** file, ensure that the specified value is the name of a stanza that is defined in the **/etc/security/pwdalg.cfg** file.

### *Extending password restrictions:*

The rules used by the password program to accept or reject passwords (the password composition restrictions) can be extended by system administrators to provide site-specific restrictions.

Restrictions are extended by adding methods, which are called during a password change. The **pwdchecks** attribute in the **/etc/security/user** file specifies the methods called.

The *AIX Version 6.1 Technical Reference* contains a description of the **pwdrestrict\_method**, the subroutine interface to which specified password restriction methods must conform. To correctly extend the password composition restrictions, the system administrator must program this interface when writing a password-restriction method. Use caution in extending the password-composition restrictions. These extensions directly affect the **login** command, the **passwd** command, the **su** command, and other programs. The security of the system could easily be subverted by malicious or defective code.

## User authentication

Identification and authentication are used to establish a user's identity.

Each user is required to log in to the system. The user supplies the user name of an account and a password if the account has one (in a secure system, all accounts must either have passwords or be invalidated). If the password is correct, the user is logged in to that account; the user acquires the access rights and privileges of the account. The **/etc/passwd** and **/etc/security/passwd** files maintain user passwords.

By default users are defined in the Files registry. This means that user account and group information is stored in the flat-ASCII files. With the introduction of plug-in load modules, users can be defined in other registries too. For example, when the LDAP plug-in module is used for user administration, then the user definitions are stored in the LDAP repository. In this case there will be no entry for users in the **/etc/security/user** file (there is an exception to this for the user attributes **SYSTEM** and **registry**). When a compound load module (i.e. load modules with an authentication and database part) is used for user administration, the database half determines how AIX user account information is administrated, and the authentication half describes the authentication and password related administration. The authentication half may also describe authentication-specific user account administration attributes by implementing certain load module interfaces (newuser, getentry, putentry etc).

Alternative methods of authentication are integrated into the system by means of the **SYSTEM** attribute that appears in **/etc/security/user** file. The **SYSTEM** attribute allows the system administrator to specify to a fine granularity to which method (or methods) a user must successfully authenticate in order to gain access to the system. For instance, the Distributed Computing Environment (DCE) requires password

authentication but validates these passwords in a different manner than the encryption model used in the **/etc/passwd** command and the **/etc/security/passwd** command.

The value of the **SYSTEM** attribute is defined through a grammar. By using this grammar, the system administrators can combine one or more methods to authenticate a particular user to the system. The well known method tokens are **compat**, **DCE**, **files** and **NONE**.

The system default is **compat**. The default **SYSTEM=compat** tells the system to use the local database for authentication and, if no resolution is found, the Network Information Services (NIS) database is tried. The **files** token specifies that only local files are to be used during authentication, whereas **SYSTEM=DCE** results in a DCE authentication flow.

The **NONE** token turns off method authentication. To turn off all authentication, the **NONE** token must appear in the **SYSTEM** and **auth1** lines of the user's stanza.

You can specify two or more methods and combine them with the logical constructors **AND** and **OR**. For instance **SYSTEM=DCE OR compat** indicates that the user is allowed to login if either DCE or local authentication (**crypt()**) succeeds in this given order.

In a similar fashion a system administrator can use authentication load module names for the **SYSTEM** attribute. For instance when **SYSTEM** attribute is set to **SYSTEM=KRB5files OR compat**, the AIX host will first try a Kerberos flow for authentication and if it fails, then it will try standard AIX authentication.

**SYSTEM** and **registry** attributes are always stored on the local file system in the **/etc/security/user** file. If an AIX user is defined in LDAP and the **SYSTEM** and **registry** attributes are set accordingly, then the user will have an entry in the **/etc/security/user** file.

The **SYSTEM** and **registry** attributes of a user can be changed using the **chuser** command.

Acceptable tokens for the **SYSTEM** attribute can be defined in the **/usr/lib/security/methods.cfg** file.

**Note:** The root user is always authenticated by means of the local system security file. The **SYSTEM** attribute entry for the root user is specifically set to **SYSTEM=compat** in the **/etc/security/user** file.

Alternative methods of authentication are integrated into the system by means of the **SYSTEM** attribute that appears in **/etc/security/user**. For instance, the Distributed Computing Environment (DCE) requires password authentication but validates these passwords in a manner different from the encryption model used in **etc/passwd** and **/etc/security/passwd**. Users who authenticate by means of DCE can have their stanza in **/etc/security/user** set to **SYSTEM=DCE**.

Other **SYSTEM** attribute values are **compat**, **files**, and **NONE**. The **compat** token is used when name resolution (and subsequent authentication) follows the local database, and if no resolution is found, the Network Information Services (NIS) database is tried. The **files** token specifies that only local files are to be used during authentication. Finally, the **NONE** token turns off method authentication. To turn off all authentication, the **NONE** token must appear in the **SYSTEM** and **auth1** lines of the user's stanza.

Other acceptable tokens for the **SYSTEM** attribute can be defined in **/usr/lib/security/methods.cfg**.

**Note:** The root user is always authenticated by means of the local system security file. The **SYSTEM** attribute entry for the root user is specifically set to **SYSTEM = "compat"** in **/etc/security/user**.

See *Operating system and device management* for more information on protecting passwords.

## Login user IDs

All audit events recorded for this user are labeled with this ID and can be examined when you generate audit records. See *Operating system and device management* for more information about login user IDs.

## User and Group attributes supported by the Authentication Load Modules

A set of user-related and group-related attributes are used to achieve identification and authentication in AIX.

The following tables list most of these user and group attributes as a list and also indicate the support from the various load modules for these attributes. Each row of the table corresponds to an attribute and each column represents a load module. Attributes supported by a load module are indicated with a Yes in the load module column.

**Note:** PKI and Kerberos are authentication-only modules and must be combined with a database model (such as LOCAL or LDAP). They support certain additional (extended) attributes other than those provided by LOCAL or LDAP. Markings are shown against only these extended attributes for these modules, even though other attributes could be functionally achieved using LOCAL or LDAP.

Table 7. User attributes and Authentication Load Module support

| User attribute                                                                         | Local | NIS/NIS+ | LDAP | PKI | Kerberos |
|----------------------------------------------------------------------------------------|-------|----------|------|-----|----------|
| account_locked                                                                         | Yes   | No       | Yes  | No  | No       |
| admchk                                                                                 | No    | No       | No   | No  | Yes      |
| admgroups                                                                              | Yes   | No       | Yes  | No  | No       |
| admin                                                                                  | Yes   | No       | Yes  | No  | No       |
| auditclasses                                                                           | Yes   | No       | Yes  | No  | No       |
| auth_cert                                                                              | No    | No       | No   | Yes | No       |
| auth_domain                                                                            | Yes   | No       | Yes  | No  | No       |
| auth_name                                                                              | Yes   | No       | Yes  | No  | No       |
| auth1<br><b>Note:</b> The <b>auth1</b> attribute is deprecated and should not be used. | Yes   | No       | Yes  | No  | No       |
| auth2<br><b>Note:</b> The <b>auth2</b> attribute is deprecated and should not be used. | Yes   | No       | Yes  | No  | No       |
| capabilities                                                                           | Yes   | No       | Yes  | No  | No       |
| core                                                                                   | Yes   | No       | Yes  | No  | No       |
| core_compress                                                                          | Yes   | No       | No   | No  | No       |
| core_hard                                                                              | Yes   | No       | Yes  | No  | No       |
| core_naming                                                                            | Yes   | No       | No   | No  | No       |
| core_path                                                                              | Yes   | No       | No   | No  | No       |
| core_pathname                                                                          | Yes   | No       | No   | No  | No       |
| cpu                                                                                    | Yes   | No       | Yes  | No  | No       |
| daemon                                                                                 | Yes   | No       | Yes  | No  | No       |
| data                                                                                   | Yes   | No       | Yes  | No  | No       |
| data_hard                                                                              | Yes   | No       | Yes  | No  | No       |
| dce_export                                                                             | Yes   | No       | Yes  | No  | No       |
| dictionlist                                                                            | Yes   | No       | Yes  | No  | No       |

Table 7. User attributes and Authentication Load Module support (continued)

| User attribute               | Local | NIS/NIS+ | LDAP | PKI | Kerberos |
|------------------------------|-------|----------|------|-----|----------|
| expires                      | Yes   | No       | Yes  | No  | Yes      |
| flags                        | Yes   | No       | Yes  | No  | No       |
| fsize                        | Yes   | No       | Yes  | No  | No       |
| fsize_hard                   | Yes   | No       | Yes  | No  | No       |
| funcmode                     | Yes   | No       | Yes  | No  | No       |
| gecos                        | Yes   | Yes      | Yes  | No  | No       |
| groups                       | Yes   | Yes      | Yes  | No  | No       |
| groupsids                    | Yes   | Yes      | Yes  | No  | No       |
| histexpire                   | Yes   | No       | Yes  | No  | No       |
| home                         | Yes   | Yes      | Yes  | No  | No       |
| host_last_login              | Yes   | No       | Yes  | No  | No       |
| host_last_unsuccessful_login | Yes   | Yes      | Yes  | No  | No       |
| hostsallowedlogin            | Yes   | No       | Yes  | No  | No       |
| hostsdeniedlogin             | Yes   | No       | Yes  | No  | No       |
| id                           | Yes   | Yes      | Yes  | No  | No       |
| krb5_attributes              | No    | No       | No   | No  | Yes      |
| krb5_kvno                    | No    | No       | No   | No  | Yes      |
| krb5_last_pwd_change         | No    | No       | No   | No  | Yes      |
| krb5_max_renewable_life      | No    | No       | No   | No  | Yes      |
| krb5_mknvo                   | No    | No       | No   | No  | Yes      |
| krb5_mod_date                | No    | No       | No   | No  | Yes      |
| krb5_mod_name                | No    | No       | No   | No  | Yes      |
| krb5_names                   | No    | No       | No   | No  | Yes      |
| krb5_principal               | No    | No       | No   | No  | Yes      |
| krb5_principal_name          | No    | No       | No   | No  | Yes      |
| krb5_realm                   | No    | No       | No   | No  | Yes      |
| lastupdate                   | Yes   | Yes      | Yes  | No  | No       |
| login                        | Yes   | No       | Yes  | No  | No       |
| loginretries                 | Yes   | No       | Yes  | No  | No       |
| logintimes                   | Yes   | No       | Yes  | No  | No       |
| maxage                       | Yes   | Yes      | Yes  | No  | Yes      |
| maxexpired                   | Yes   | Yes      | Yes  | No  | No       |
| maxrepeats                   | Yes   | No       | Yes  | No  | No       |
| maxulogs                     | Yes   | No       | Yes  | No  | No       |
| minage                       | Yes   | Yes      | Yes  | No  | No       |
| minalpha                     | Yes   | No       | Yes  | No  | No       |
| mindiff                      | Yes   | No       | Yes  | No  | No       |
| minlen                       | Yes   | No       | Yes  | No  | No       |
| minother                     | Yes   | No       | Yes  | No  | No       |
| nofiles                      | Yes   | No       | Yes  | No  | No       |

Table 7. User attributes and Authentication Load Module support (continued)

| User attribute               | Local | NIS/NIS+ | LDAP | PKI | Kerberos |
|------------------------------|-------|----------|------|-----|----------|
| nofiles_hard                 | Yes   | No       | Yes  | No  | No       |
| password                     | Yes   | Yes      | Yes  | No  | No       |
| pgid                         | Yes   | Yes      | No   | No  | No       |
| pgrp                         | Yes   | Yes      | Yes  | No  | No       |
| projects                     | Yes   | No       | Yes  | No  | No       |
| pwdchecks                    | Yes   | No       | Yes  | No  | No       |
| pwdwarntime                  | Yes   | No       | Yes  | No  | No       |
| rcmds                        | Yes   | No       | Yes  | No  | No       |
| registry                     | Yes   | No       | No   | No  | No       |
| rlogin                       | Yes   | No       | Yes  | No  | No       |
| roles                        | Yes   | No       | Yes  | No  | No       |
| rss                          | Yes   | No       | Yes  | No  | No       |
| rss_hard                     | Yes   | No       | Yes  | No  | No       |
| screens                      | Yes   | No       | Yes  | No  | No       |
| shell                        | Yes   | Yes      | Yes  | No  | No       |
| spassword                    | Yes   | Yes      | Yes  | No  | No       |
| stack                        | Yes   | No       | Yes  | No  | No       |
| stack_hard                   | Yes   | No       | Yes  | No  | No       |
| su                           | Yes   | No       | Yes  | No  | No       |
| sugroups                     | Yes   | No       | Yes  | No  | No       |
| sysenv                       | Yes   | No       | Yes  | No  | No       |
| SYSTEM                       | Yes   | No       | No   | No  | No       |
| time_last_login              | Yes   | No       | Yes  | No  | No       |
| time_last_unsuccessful_login | Yes   | No       | Yes  | No  | No       |
| tpath                        | Yes   | No       | Yes  | No  | No       |
| tty_last_login               | Yes   | No       | Yes  | No  | No       |
| tty_last_unsuccessful_login  | Yes   | No       | Yes  | No  | No       |
| ttys                         | Yes   | No       | Yes  | No  | No       |
| umask                        | Yes   | No       | Yes  | No  | No       |
| unsuccessful_login_count     | Yes   | No       | Yes  | No  | No       |
| unsuccessful_login_times     | Yes   | No       | Yes  | No  | No       |
| usrenv                       | Yes   | No       | Yes  | No  | No       |

Table 8. Group attributes and Authentication Load Module support

| User attribute | Local | NIS/NIS+ | LDAP | PKI | Kerberos |
|----------------|-------|----------|------|-----|----------|
| admin          | Yes   | No       | Yes  | No  | No       |
| adms           | Yes   | No       | Yes  | No  | No       |
| dce_export     | Yes   | No       | Yes  | No  | No       |
| id             | Yes   | Yes      | Yes  | No  | No       |
| primary        | Yes   | No       | Yes  | No  | No       |

Table 8. Group attributes and Authentication Load Module support (continued)

| User attribute | Local | NIS/NIS+ | LDAP | PKI | Kerberos |
|----------------|-------|----------|------|-----|----------|
| projects       | Yes   | No       | Yes  | No  | No       |
| screens        | Yes   | No       | Yes  | No  | No       |
| users          | Yes   | Yes      | Yes  | No  | No       |

## Disk quota system overview

The disk quota system allows system administrators to control the number of files and data blocks that can be allocated to users or groups.

### **Disk quota system concept:**

The disk quota system, based on the Berkeley Disk Quota System, provides an effective way to control the use of disk space. The quota system can be defined for individual users or groups, and is maintained for each journaled file system (JFS and JFS2).

The disk quota system establishes limits based on the following parameters that can be changed with the **edquota** command for JFS file systems and the **j2edlimit** command for JFS2 file systems:

- User's or group's soft limits
- User's or group's hard limits
- Quota grace period

The *soft limit* defines the number of 1 KB disk blocks or files the user or group will be allowed to use during normal operations. The *hard limit* defines the maximum amount of disk blocks or files the user can accumulate under the established disk quotas. The *quota grace period* allows the user to exceed the soft limit for a short period of time (the default value is one week). If the user fails to reduce usage below the soft limit during the specified time, the system will interpret the soft limit as the maximum allocation allowed, and no further storage is allocated to the user. The user can reset this condition by removing enough files to reduce usage below the soft limit.

The disk quota system tracks user and group quotas in the **quota.user** and **quota.group** files that reside in the root directories of file systems enabled with quotas. These files are created with the **quotacheck** and **edquota** commands and are readable with the quota commands.

### **Recovering from over-quota conditions:**

You can recover from over-quota conditions by reducing file system usage.

To reduce file system usage when you have exceeded quota limits, you can use the following methods:

- Stop the current process that caused the file system to reach its limit, remove surplus files to bring the limit below quota, and retry the failed program.
- If you are running an editor such as vi, use the shell escape sequence to check your file space, remove surplus files, and return without losing your edited file. Alternatively, if you are using the C or Korn shells, you can suspend the editor with the Ctrl-Z key sequence, issue the file system commands, and then return with the **fg** (foreground) command.
- Temporarily write the file to a file system where quota limits have not been exceeded, delete surplus files, and then return the file to the correct file system.

### **Setting up the disk quota system:**

Typically, only those file systems that contain user home directories and files require disk quotas.

Consider implementing the disk quota system under the following conditions:

- Your system has limited disk space.
- You require more file-system security.
- Your disk-usage levels are large, such as at many universities.

If these conditions do not apply to your environment, you might not want to create disk-usage limits by implementing the disk quota system.

The disk quota system can be used only with the journaled file system.

**Note:** Do not establish disk quotas for the **/tmp** file system.

To set up the disk quota system, use the following procedure:

1. Log in with root authority.
2. Determine which file systems require quotas.

**Note:** Because many editors and system utilities create temporary files in the **/tmp** file system, it must be free of quotas.

3. Use the **chfs** command to include the **userquota** and **groupquota** quota configuration attributes in the **/etc/filesystems** file. The following example uses the **chfs** command to enable user quotas on the **/home** file system:

```
chfs -a "quota = userquota" /home
```

To enable both user and group quotas on the **/home** file system, type:

```
chfs -a "quota = userquota,groupquota" /home
```

The corresponding entry in the **/etc/filesystems** file is displayed as follows:

```
/home:
dev = /dev/hd1
vfs = jfs
log = /dev/hd8
mount = true
check = true
quota = userquota,groupquota
options = rw
```

4. Optionally, specify alternate disk quota file names. The **quota.user** and **quota.group** file names are the default names located at the root directories of the file systems enabled with quotas. You can specify alternate names or directories for these quota files with the **userquota** and **groupquota** attributes in the **/etc/filesystems** file.

The following example uses the **chfs** command to establish user and group quotas for the **/home** file system, and names the **myquota.user** and **myquota.group** quota files:

```
chfs -a "userquota = /home/myquota.user" -a "groupquota = /home
/myquota.group" /home
```

The corresponding entry in the **/etc/filesystems** file is displayed as follows:

```
/home:
dev = /dev/hd1
vfs = jfs
log = /dev/hd8
mount = true
check = true
quota = userquota,groupquota
userquota = /home/myquota.user
groupquota = /home/myquota.group
options = rw
```

5. If they are not previously mounted, mount the specified file systems.

6. Set the desired quota limits for each user or group. Use the **edquota** command to create each user or group's soft and hard limits for allowable disk space and maximum number of files.

The following example entry shows quota limits for the *davec* user:

```
Quotas for user davec:
/home: blocks in use: 30, limits (soft = 100, hard = 150)
 inodes in use: 73, limits (soft = 200, hard = 250)
```

This user has used 30 KB of the maximum 100 KB of disk space. Of the maximum 200 files, *davec* has created 73. This user has buffers of 50 KB of disk space and 50 files that can be allocated to temporary storage.

When establishing disk quotas for multiple users, use the **-p** flag with the **edquota** command to duplicate a user's quotas for another user.

To duplicate the quotas established for user *davec* for user *nanc*, type:

```
edquota -p davec nanc
```

7. Enable the quota system with the **quotaon** command. The **quotaon** command enables quotas for a specified file system, or for all file systems with quotas (as indicated in the */etc/filesystems* file) when used with the **-a** flag.
8. Use the **quotacheck** command to check the consistency of the quota files against actual disk usage.

**Note:** Do this each time you first enable quotas on a file system and after you reboot the system. The **quotacheck** command takes longer to run on a JFS filesystem than on a JFS2 filesystem of the same size. If quotas are enabled all the time prior to reboot, it is not necessary to run the **quotacheck** command on the filesystem during reboot.

To enable this check and to turn on quotas during system startup, add the following lines at the end of the */etc/rc* file:

```
echo " Enabling filesystem quotas "
/usr/sbin/quotacheck -a
/usr/sbin/quotaon -a
```

## Role Based Access Control (RBAC)

System administration is an important aspect of daily operations, and security is an inherent part of most system administration functions. Also, in addition to securing the operating environment, it is necessary to closely monitor daily system activities.

Most environments require that different users manage different system administration duties. It is necessary to maintain separation of these duties so that no single system management user can accidentally or maliciously bypass system security. While traditional UNIX system administration cannot achieve these goals, Role Based Access Control (RBAC) can.

### Traditional UNIX administration limitations

RBAC resolves some traditional UNIX system administration issues. These issues include the following:

#### root administrative account

Traditionally, AIX and other UNIX operating systems have defined a single system administrator account named **root** (normally designated with a UID of 0) that can perform all privileged system administration tasks on the system. Reliance on a single user for all system administration tasks is a problem in regard to the separation of duties. While a single administrative account is acceptable in certain environments, many environments require multiple administrators, with each administrator responsible for different system administration tasks.

In order to share the administration responsibilities with multiple users of the system, the historical practice was to either share the password of the root user or create another user with the same UID as the root user. This method of sharing system administration duties presents security issues, since each



administrator has complete system control and there is no method to limit the operations that an administrator can perform. Since the root user is the most privileged user, root users can perform unauthorized operations and can also erase any audits of these activities, making it impossible to track these administrative actions.

## Privilege escalation through SUID

Access control in UNIX operating systems has historically been performed by using the UID associated with the process to determine access. However, the root UID of 0 has traditionally been allowed to bypass permission checks. Therefore, a process that is running as the root user can pass any access checks and perform any operation. This is a security issue for the UNIX concept of **setuid** applications.

The **setuid** concept allows a command to run under a different identity than the user who invoked the command. This is necessary when a normal user needs to accomplish a privileged task. An example of this is the AIX **passwd** command. Since a normal user does not have access to the file that stores user passwords, an additional privilege is needed to change the user's password, so the **passwd** command is **setuid** to the root user. When a normal user runs the **passwd** command, it appears to the operating system that the root user is accessing the file and the access is granted.

While this concept does provide the desired functionality, it carries with it an inherent risk. Since the **setuid** program is effectively running in the root context, if an attacker successfully takes over the program before it exits, then the attacker has all of the powers of root and can then bypass all operating system access checks and perform all operations. A better solution is to only assign a subset of the root user privileges to the program so that the "Least privilege principal" on page 74 is followed and the threat is mitigated.

## Elements of RBAC

RBAC allows the creation of roles for system administration and the delegation of administrative tasks across a set of trusted system users. In AIX, RBAC provides a mechanism through which the administrative functions typically reserved for the root user can be assigned to regular system users.

RBAC accomplishes this by defining job functions (roles) within an organization and assigning those roles to specific users. RBAC is essentially a framework that allows for system administration through the use of roles. Roles are typically defined with the scope of managing one or more administrative aspects of the environment. Assigning a role to a user effectively confers a set of permissions or privileges and powers to the user. For example, one management role might be to manage the filesystems, while another role might be to enable the creation of user accounts.

RBAC administration has the following advantages as compared to traditional UNIX administration:

- System administration can be performed by multiple users without sharing account access.
- Security isolation through granular administration since each administrator does not need to be granted more power than is required.
- Allows for enforcing a least-privilege security model. Users and applications are only granted necessary privileges when required, thereby reducing the impact a system attacker can have.
- Allows for implementing and enforcing company-wide security policies consistently in regard to system management and access control.
- A role definition can be created once and then assigned to users or removed as needed when users change job functions.

The RBAC framework is centered on the following three core concepts:

- Authorizations
- Roles
- Privileges

Together, these concepts allow an RBAC system to enforce the least-privilege principle.

**Authorizations:**

An authorization is a text string associated with security-related functions or commands. Authorizations provide a mechanism to grant rights to users to perform privileged actions and to provide different levels of functionality to different classes of users.

When a command governed by an authorization is run, access is granted only if the invoking user has the required authorization. An authorization can be thought of as a key that is able to unlock access to one or more commands. Authorizations are not directly assigned to users. Users are assigned roles, which are a collection of authorizations.

**Roles:**

Roles allow a set of management functions in the system to be grouped together. Using the analogy that an authorization is a key, a role can be thought of as a key ring that can hold multiple authorizations. Authorizations may be directly assigned to a role or indirectly assigned through a sub-role. A sub-role is simply another role that a given role inherits the authorizations from.

A role by itself does not grant the user any additional powers, but instead serves as a collection mechanism for authorizations and a facility for assigning authorizations to a user. Defining a role and assigning the role to a user determines the system administration tasks that can be performed by the user. After a role has been defined, the role administrator can assign the role to one or more users to manage the privileged operations that are represented by the role. Additionally, a user can be assigned multiple roles. Once a role has been assigned to a user, the user can use the authorizations assigned to the role to unlock access to administrative commands on the system.

Organizational policies and procedures determine how to allocate roles to users. Do not assign too many authorizations to a role or assign a role to too many users. Most roles should only be assigned to members of the administrative staff. Just as the powers of root have historically only been given to trusted users, roles should only be assigned to trusted users. Grant roles only to users with legitimate needs and only for the duration of the need. This practice reduces the chances that an unauthorized user can acquire or abuse authorizations.

**Privileges:**

A privilege is a process attribute that allows the process to bypass specific system restrictions and limitations.

The privilege mechanism provides trusted applications with capabilities that are not permitted to untrusted applications. For example, privileges can be used to override security constraints, to permit the expanded use of certain system resources such as memory and disk space, and to adjust the performance and priority of a process. A privilege can be thought of as an ability that allows a process to overcome a specific security constraint in the system.

Authorizations and roles are user-level tools that configure a user's ability to access privileged operations. On the other hand, privileges are the restriction mechanism used in the kernel to determine if a process is allowed to perform a particular action.

Privileges are associated with a process and are typically acquired through the invocation of a privileged command. Because of these associated privileges, the process is eligible to perform the related privileged operation. For example, if a user uses a role that has an authorization to run a command, a set of privileges is assigned to the process when the command is run.

*Least privilege principal:*

In an operating system, some operations are privileged and permission to perform these operations is restricted to authorized users. These privileged operations usually include tasks such as rebooting the system, adding and modifying filesystems, adding and deleting users, and modifying the system date and time.

In traditional UNIX systems, a process or user can be in normal mode or privileged mode (also called superuser or root). A process running as root can execute any command and perform any system operation, while a normal user cannot perform privileged operations. A traditional UNIX system has a very coarse all-or-nothing concept of privilege and faces the security threat of the overprivileged administrator.

The traditional UNIX approach where a single privileged mode grants all access to the system is too coarse to meet the requirements of highly secured systems. A system designed to be secure requires that each process be granted the most restrictive set of privileges needed to perform a task. Privileges provide the advantage that only processes that require certain privileges need to be granted these privileges. This restriction of privileges is known as the principle of least privilege and is useful in limiting damage to the system due to careless or malicious administrators and operators.

For example, changing a password requires certain privileges in order to access files that are not typically accessible by a normal user. If users always had these privileges, they could also perform other actions that are undesirable from a security standpoint. Therefore, the required privileges are granted only to the **passwd** command and not to all users.

In an RBAC environment, users themselves do not have any inherent privileges. Users are simply allowed to run certain commands which are then granted privileges. If a user was instead directly granted privileges, they could use the privileges at any time and in any manner wanted. Limiting privileges to individual commands allows the context in which the privileges are applied to be constrained. This leads to enhanced security because if a trusted application is exploited by an attacker, the attacker will have a limited set of privileges instead of the whole powers of root with all privileges.

Trusted applications should be carefully inspected before they are granted privileges. In addition, privileges should only be granted when and where necessary for the application. Trusted applications are just like any other program, the only difference being that trusted applications are allowed to perform actions that are denied to untrusted applications.

## **AIX RBAC**

AIX has provided a limited RBAC implementation since AIX 4.2.1.

Beginning with AIX 6.1, a new implementation of RBAC provides for a very fine granular mechanism to segment system administration tasks. Since these two RBAC implementations differ greatly in functionality, the following terms are used:

### **Legacy RBAC Mode**

The historic behavior of AIX roles that was introduced in AIX 4.2.1

### **Enhanced RBAC Mode**

The new implementation introduced with AIX 6.1

Both modes of operation are supported. However, Enhanced RBAC Mode is the default on a newly installed AIX 6.1 system. The following sections provide a brief discussion of the two modes and their differences, and information on configuring the system to operate in the desired RBAC mode.

### ***Legacy RBAC Mode:***

AIX 4.2.1 provided limited RBAC functionality that allowed non-root users to perform certain system administration tasks.

In this RBAC implementation, when a given administrative command is invoked by a non-root user, the code in the command determines if the user is assigned a role with the required authorization. If a match is found, the command execution continues. If not, the command fails with an error. It is often required that the command being controlled by an authorization be **setuid** to the root user for an authorized invoker to have the necessary privilege to accomplish the operation.

This RBAC implementation also introduced a predefined but user-expandable set of authorizations that can be used to determine access to administrative commands. Additionally, a framework of administrative commands and interfaces to create roles, assign authorizations to roles, and assign roles to users is also provided.

While this implementation provides the ability to partially segment system administration responsibilities, it functions with the following constraints:

1. The framework requires changes to commands and applications to be RBAC-enabled.
2. Predefined authorizations are not granular and the mechanisms to create authorizations are not robust.
3. Membership in a certain group is often required as well as having a role with a given authorization in order to run a command.
4. Separation of duties is difficult to implement. If a user is assigned multiple roles, there is no way to act under a single role. The user always has all of the authorizations for all of their roles.
5. The least privilege principle is not adopted in the operating system. Commands must typically be SUID to the root user.

Legacy RBAC Mode is supported for compatibility, but Enhanced RBAC Mode is the default RBAC mode. Enhanced RBAC Mode is preferred on AIX.

#### ***Enhanced RBAC Mode:***

A more powerful implementation of RBAC is provided with AIX 6.1. Applications that require administrative privileges for certain operations have new integration options with the enhanced AIX RBAC infrastructure.

These integration options center on the use of granular privileges and authorizations and the ability to configure any command on the system as a privileged command. Features of the enhanced RBAC mode will be installed and enabled by default on all installations of AIX beginning with AIX 6.1.

The enhanced RBAC mode provides a configurable set of authorizations, roles, privileged commands, devices and files through the following RBAC databases listed below. With enhanced RBAC, the databases can reside either in the local filesystem or can be managed remotely through LDAP.

- Authorization database
- Role database
- Privileged command database
- Privileged device database
- Privileged file database

Enhanced RBAC mode introduces a new naming convention for authorizations that allows a hierarchy of authorizations to be created. AIX provides a granular set of system-defined authorizations and an administrator is free to create additional user-defined authorizations as necessary.

The behavior of roles has been enhanced to provide separation of duty functionality. Enhanced RBAC introduces the concept of role sessions. A role session is a process with one or more associated roles. A user can create a role session for any roles that they have been assigned, thus activating a single role or several selected roles at a time. By default, a new system process does not have any associated roles. Roles have further been enhanced to support the requirement that the user must authenticate before activating the role to protect against an attacker taking over a user session since the attacker would then need to authenticate to activate the user's roles.

The introduction of the privileged command database implements the least privilege principle. The granularity of system privileges has been increased, and explicit privileges can be granted to a command and the execution of the command can be governed by an authorization. This provides the functionality to enforce authorization checks for command execution without requiring a code change to the command itself. Use of the privileged command database eliminates the requirement of SUID and SGID applications since the capability of only assigning required privileges is possible.

The privileged device database allows access to devices to be governed by privileges, while the privileged file database allows unprivileged users access to restricted files based on authorizations. These databases increase the granularity of system administrative tasks that can be assigned to users who are otherwise unprivileged.

The information in the RBAC databases is gathered and verified and then sent to an area of the kernel designated as the Kernel Security Tables (KST). It is important to note that the state of the data in the KST determines the security policy for the system. Entries that are modified in the user-level RBAC databases are not used for security decisions until this information has been sent to the KST with the **setkst** command.

### ***Configuring the RBAC mode:***

The RBAC mode is controlled by a system-wide configuration variable in the kernel. This variable specifies whether Enhanced RBAC Mode is enabled or disabled.

Enhanced RBAC mode is enabled by default on AIX 6.1. You can run the **chdev** command on the **sys0** device and specify a value of **false** for the **enhanced\_RBAC** attribute to disable enhanced RBAC mode and revert to legacy RBAC mode. You must reboot the system for the change to the **enhanced\_RBAC** attribute to take effect. To enable the enhanced RBAC mode, the **enhanced\_RBAC** attribute should be set to **true**. Programmatically, the mode can also be set or queried through the **sys\_parm()** system call.

Run the following command on the system to retrieve the current RBAC mode:

```
lsattr -E -l sys0 -a enhanced_RBAC
```

You can disable the enhanced RBAC mode by running the following command and then rebooting the system:

```
chdev -l sys0 -a enhanced_RBAC=false
```

In a WPAR environment, the RBAC mode can only be configured from the global system and will uniformly affect the global as well as all of the WPARs on the system.

### ***Legacy RBAC mode and enhanced RBAC mode comparison:***

Existing and new interfaces have been modified to check the system configuration and run the new code or follow the old behavior.

In legacy RBAC mode, only authorizations that are checked within the code of the command itself are enforced. The Kernel Security Tables (KST) do not have any affect on command execution or authorization checks. Determination of whether a user has an authorization follows the legacy RBAC mode behavior of retrieving all the user's authorizations and checking for a match. New features such as the **swrole** command and the **default\_roles** and **auth\_mode** attributes are not available in legacy RBAC mode. However, the new privileges, authorizations, and management commands for authorizations are supported in legacy RBAC mode.

The following table lists some of the differences between the legacy and enhanced RBAC modes.

Table 9.

| Feature                           | Legacy RBAC                                                    | Enhanced RBAC                                                                                           |
|-----------------------------------|----------------------------------------------------------------|---------------------------------------------------------------------------------------------------------|
| Role activation                   | All of a user's roles are always active                        | By default, roles are not active until assumed explicitly via the <b>swrole</b> command                 |
| <b>default_roles</b> attribute    | Not available                                                  | Supported                                                                                               |
| <b>swrole</b> command             | Not available                                                  | Supported                                                                                               |
| Role management commands          | Supported                                                      | Supported                                                                                               |
| Authorization management commands | Supported                                                      | Supported                                                                                               |
| Authorization hierarchy           | Each authorization is independent. No hierarchy functionality. | Supports concept of authorization hierarchy where authorizations can be parents of other authorizations |
| Authorization checks              | Only enforced if command itself checks for authorization       | Enforced through Privileged Command Database and/or by the command itself                               |
| Granular Privileges               | Supported                                                      | Supported                                                                                               |
| <b>pvi</b> command                | Not available                                                  | Supported                                                                                               |
| Kernel Security Tables            | Not available                                                  | Supported                                                                                               |
| RBAC Database Location            | Local files                                                    | Local files or LDAP                                                                                     |

## Using Enhanced RBAC

System administrators should be knowledgeable in the following areas in order to effectively use Enhanced RBAC.

### **RBAC Authorizations:**

Authorizations are an important part of Role Based Access Control (RBAC). The operating system uses authorization strings to determine eligibility before performing a privileged operation. Related checks can be performed from within the code explicitly or can be done by the loader when running protected privileged executables.

The naming of authorization strings indicates the privileged operation that they represent and control. The AIX naming convention for authorizations supports a hierarchical structure that is denoted by the authorization's textual name. AIX authorization strings use a dotted notation format to describe the authorization hierarchy. For example, the authorization to create new file systems is **aix.fs.manage.create**. If this authorization is included in a role, then a user who is assigned this role can create AIX filesystems. If the parent authorization **aix.fs.manage** is included in a role, then a user who is assigned this role can perform other file system management tasks as well as create filesystems.

AIX RBAC differentiates between system-provided authorizations (system-defined authorizations) and authorizations that are created after installation (user-defined authorizations).

### *System-defined authorizations:*

AIX provides a predefined and non-modifiable set of authorizations. These are known as System-Defined Authorizations. These authorizations are associated with various privileged AIX operations; the association is specified in the Privileged Command Database.

At the top of the system-defined authorization hierarchy is the **aix** authorization. This authorization is the parent of all other system-defined authorizations. Granting this authorization to a role grants every system-defined authorization to the role. To display the complete set of AIX system-defined authorizations and a brief description of each authorization, run the following command:

```
lsauth -f -a description ALL_SYS
```

The output of the above command shows that the list of system-defined authorizations is a multi-level hierarchy. For example, the **aix** authorization has several immediate children. Each of those children is then a parent of another hierarchy. The **aix.fs** authorization includes multiple child authorizations, including **aix.fs.manage**, which in turn includes multiple authorizations such as **aix.fs.manage.change**, and **aix.fs.manage.create**.

#### *User-defined authorizations:*

In addition to system-defined authorizations, AIX RBAC allows system administrators to define their own custom authorizations in the authorization database (/etc/security/authorizations). These are known as user-defined authorizations.

A system administrator can add, modify, or delete user-defined authorizations. For example, a system administrator can allow some users to run a privileged command by creating a user-defined authorization and then associating this authorization with the command and granting the authorization to a role that is assigned to these users.

User-defined authorizations support the same hierarchy concept as system-defined authorizations. However, there are restrictions placed on the naming of AIX user-defined authorizations.

- User-defined authorizations must be defined beneath a new top-level parent. In other words, user-defined authorizations cannot be children of system-defined authorizations (**aix**).
- An authorization name can contain a maximum of 63 printable characters.
- An authorization's parent hierarchy can contain a maximum of eight levels.
- An authorization can have any number of immediate children, but can only have one immediate parent. Two independent authorizations cannot have the same immediate child.

Since the hierarchy does not allow an element to have multiple direct parents, you cannot create a user-defined authorization that is a parent of an existing system-defined authorization. Therefore, an attempt to create an authorization named **aix.custom** will fail and the creation of an authorization named **custom.aix** will result in a brand new authorization and does not function as the parent of the **aix** system-defined authorization.

The following syntax is suggested when creating user-defined authorizations to avoid conflicts between authorization names across multiple software components:

```
vendor_name.product_name.function.function1.function2...
```

*vendor\_name*

Identifies the name of the vendor of the software module.

*product\_name*

High-level product name of the product that is managed with RBAC.

*function, function1, function2 ...*

These strings represent the functions that are being managed with RBAC. These strings also provide a hierarchical representation of how these functions are organized.

For example, **ibm.db2.manage** could potentially represent the management aspects of the IBM DB2 database suite. As mentioned previously, the *vendor\_name* string **aix** is reserved for AIX use and is not allowed for user-defined authorizations.

There are several authorization management commands that system administrators can use to list, create, modify, and remove user-defined authorizations. User-defined authorizations can be created with the **mkauth** command, modified with the **chauth** command, removed by the **rmauth** command, and displayed with the **lsauth** command. To display all of the user-defined system authorizations and a brief description of each, run the following command:

```
lsauth -f -a description ALL_USR
```

Before creating a user-defined authorization, consider the following issues:

- Would it be appropriate to use an existing system-defined authorization instead of creating a new user-defined authorization?
- Does the new authorization belong beneath an existing user-defined authorization hierarchy or is it the first authorization of a new hierarchy?
- If this is a new hierarchy, what is the structure?
- What is the text description of the authorization?
- Is language translation of the authorization description required?
- Is there any reason to specify a certain authorization ID when creating the authorization? It is recommended that the **mkauth** command be used to generate the authorization ID.

After considering these issues, perform the following steps to create the authorization:

1. If language translation is required, create or add the description to a message catalog.
2. Use the **mkauth** command to create all parent authorizations in the hierarchy if these do not already exist.
3. Use the **mkauth** command to create the desired authorization. Specify the **id** attribute with the command if a specific value is required.

*Legacy authorization migration:*

Prior to AIX Version 6.1 the operating system had a limited, predefined set of authorizations that were recognized by the operating system. These authorizations were not defined in any file on the system, but could be readily assigned to roles. To support these legacy authorizations within the new AIX Version 6.1 RBAC framework, these legacy authorizations are defined as user-defined authorizations and are provided by default in the authorization database.

Since AIX is moving to a new authorization naming convention, any checks for old authorization names in AIX have been modified to additionally check for the new corresponding authorization and allow access if either authorization exists for the process. The following table lists the legacy predefined authorizations and the corresponding new system-defined authorizations.

| Existing AIX Authorization | Corresponding New Authorization |
|----------------------------|---------------------------------|
| Backup                     | aix.fs.manage.backup            |
| Diagnostics                | aix.system.config.diag          |
| DiskQuotaAdmin             | aix.fs.manage.quota             |
| GroupAdmin                 | aix.security.group              |
| ListAuditClasses           | aix.security.audit.list         |
| PasswdAdmin                | aix.security.passwd             |
| PasswdManage               | aix.security.passwd.normal      |
| UserAdmin                  | aix.security.user               |
| UserAudit                  | aix.security.user.change        |
| RoleAdmin                  | aix.security.role               |
| Restore                    | aix.fs.manage.restore           |



### **RBAC roles:**

Roles are the mechanism used to assign authorizations to a user and to group a set of system administration tasks together. An AIX role is primarily a container for a collection of authorizations.

AIX supports the direct assignment of authorizations to a role or the indirect assignment of authorizations through a sub-role. A sub-role can be specified for a role in the **rolelist** attribute of a role. Configuring a role to have a designated sub-role effectively assigns all of the authorizations in the sub-role to the role.

Assigning a role to a user allows the user to access the role and use the authorizations that are contained in the role. A system administrator can assign a role to multiple users and can assign multiple roles to a user. A user who has been assigned multiple roles can activate more than one role (up to a maximum of eight roles) simultaneously if necessary to perform system management functions.

AIX provides a set of predefined roles for system management. However it is expected that customers will need to create their own custom roles or modify the existing predefined roles. Several role-management commands are available to list, create, modify, and remove AIX roles. Roles can be created with the **mkrole** command, modified with the **chrole** command, removed with the **rmrole** command, and displayed with the **lsrole** command.

When creating a new AIX role, consider the following issues:

- What will be the name of the role?
- The role name is a text string, but should provide some insight into the role's capabilities. Role names can contain a maximum of 63 printable characters.
- What authorizations are required for the role? Consider whether authorizations should be directly assigned to the role or indirectly assigned to the role through a sub-role.
- Should the user be required to authenticate when activating the role?

### *Activating a role:*

By default in AIX Version 6.1 with enhanced RBAC, when a user authenticates to the system, the user's session does not have any associated roles or authorizations. In order to associate roles to the session, the user must invoke a separate authentication command (the **swrole** command) to switch to the role or roles.

The user can only activate roles that have previously been assigned to the user. By default, a user is required to authenticate as themselves when entering a role session or when adding a role to their session. Roles can optionally be designated to not require authentication with the **auth\_mode** role attribute.

Switching to a new role session creates a new shell (session) without inheriting roles from the prior session. This is accomplished by creating a new process shell for the role and assigning the new role ID (RID) to the process. Creation of the new session is similar to using the **su** command except in this case only the role ID of the process is changed and not characteristics such as the UID or GID. The **swrole** command allows the user to create a role session composed of a single role or multiple roles. There is no restriction to prevent a user from switching to a new role session from the current role session. Since the new session is a new process, the new session will not inherit any roles from the prior session. In order to restore the previous session, the user must exit the current role session. The roles assumed in a session (the active role set) can be listed by running the **rolelist** command in the session. An administrator can also use the **rolelist** command to list the active role set for a given system process.

A user can optionally be assigned a default set of roles with the new **default\_roles** user attribute. This attribute is intended for situations where processes that are created on behalf of a user always need to be

associated with a given set of roles, for example, the **cron** command. The cron facility runs in the background and runs commands as the defined user. It is possible that some of the commands that are run may require authorizations. This requires the ability to designate that a set of roles always be active for a user ID since there is no mechanism for the **cron** command to later acquire these roles. The **default\_roles** attribute can be set to include up to eight role names or the special value of **ALL**. Setting **default\_roles=ALL** assigns all of the user's roles to the session. If the user has been assigned more than eight roles, then only the first eight roles will be enabled for the session.

*Maximum number of roles per session:*

In enhanced RBAC, a system administrator can configure on a system-wide basis the maximum number of roles that a user can activate in a given role session. By default, a user can activate up to eight roles in a session.

Certain environments may require a greater separation of duties in which a user can only activate a single role at a time. In these environments, the **maxroles** attribute of the **usw** stanza in the **/etc/security/login.cfg** file can be modified to restrict the maximum allowed number of roles per session. The **maxroles** attribute can be set to a value in the range of 1 to 8 to specify the maximum allowable number of roles per session.

To display the current value of the restriction on the number of roles per session, run the following command:

```
lssec -f /etc/security/login.cfg -s usw -a maxroles
```

To modify the system to allow a user to only activate a single role at a time, run the following command:

```
chsec -f /etc/security/login.cfg -s usw -a maxroles=1
```

Modification of the **maxroles** attribute value is effective immediately for any new role sessions that are created and does not require a system reboot. Role sessions that existed prior to the modification of the value are not affected by the change. The enforcement of the maximum number of roles per session is performed at session initiation.

*Predefined roles:*

A predefined set of roles is defined in the local role database (**/etc/security/roles**) on a new AIX Version 6.1 installation. This set of roles is intended to group typical administrative responsibilities.

This set of roles serves as a suggested means of dividing administrative duties. Role administrators can modify or remove these roles or create new roles as needed for their environment. The following lists the provided roles and a brief description of each role's abilities.

| Role name | Role description                                                                                                                                                                                                                                                                                                                                                                                  |
|-----------|---------------------------------------------------------------------------------------------------------------------------------------------------------------------------------------------------------------------------------------------------------------------------------------------------------------------------------------------------------------------------------------------------|
| isso      | Information System Security Officer. An ISSO is responsible for creating and assigning roles and is therefore the most powerful role on the system. Some ISSO responsibilities include: <ul style="list-style-type: none"> <li>• Establishing and maintaining security policy</li> <li>• Setting passwords for users</li> <li>• Network configuration</li> <li>• Device administration</li> </ul> |

| Role name | Role description                                                                                                                                                                                                                                                                                                                                            |
|-----------|-------------------------------------------------------------------------------------------------------------------------------------------------------------------------------------------------------------------------------------------------------------------------------------------------------------------------------------------------------------|
| sa        | System Administrator. The SA role provides functionality for daily administration and is responsible for: <ul style="list-style-type: none"> <li>• User administration (except password setting)</li> <li>• File system administration</li> <li>• Software installation update</li> <li>• Network daemon management</li> <li>• Device allocation</li> </ul> |
| so        | System Operator. The SO role provides functionality for day to day operations and is responsible for: <ul style="list-style-type: none"> <li>• System shutdown and reboot</li> <li>• File system backup, restore and quotas</li> <li>• System error logging, trace and statistics</li> <li>• Workload administration</li> </ul>                             |

*Role migration:*

If an AIX system prior to AIX Version 6.1 is being updated to an AIX enhanced RBAC level via a migration install, migration of the **/etc/security/roles** file attempts to update the file for the new functionality while maintaining the current role abilities.

Role definitions in the file are preserved and are simply modified to include a unique role ID to allow the role to function properly in the new framework. Any authorizations in the **/etc/security/roles** file that are not known predefined authorizations are considered user-defined authorizations. During migration, these authorization names are added as entries in the local **/etc/security/authorizations** authorization database. In addition to migration of the old role definitions, the new predefined roles are appended to the file. After migration, the system administrator must verify that the authorizations and roles are defined as needed for the environment.

**RBAC privileges:**

The enhanced RBAC framework relies heavily on system privileges to allow non-privileged users to perform privileged tasks. A privilege is a mechanism used to grant a process augmented functionality in system calls.

The concept of privileges is primarily a kernel-level construct since the definition and most of the checking occurs in the kernel. However, user-level interfaces are provided to handle the assignment of privileges to commands, devices, and processes.

It is important to note the difference between privileges and authorizations. Both privileges and authorizations are used to control certain allowable exceptions to system security policy. The defining difference between privileges and authorizations is that privileges are associated with specific processes, while authorizations are associated with users through roles. Authorizations reside with a role and the user who has the role, and do not depend on the program that is being run. Privileges reside with the program and provide the mechanism to fine tune the system security policy. Because of these associated privileges, the process is eligible to perform the related privileged operation.

Privileges are defined in the AIX kernel as individual bits of a bit-mask which enforce access control over privileged operations. Over 100 privileges are provided with AIX, providing for a very fine granular control of privileged operations. When determining access in a system call, the kernel determines if the process has the required associated privilege bit and then grants or denies the request.

Privileges are assigned to command invocations through the privileged command database and privileges are used to control access to devices through the privileged device database.

#### *Privilege naming and hierarchy:*

AIX privileges cannot be created, modified or deleted by a system administrator.

The list of available privileges and a brief description of the privilege can be displayed on a system by running the following command:

```
lspriv -v
```

The privileges provided on AIX are listed in AIX privileges. All AIX privileges have a textual representation of the privilege bit that begins with **PV\_**. The naming convention used after the **PV\_** prefix denotes the hierarchical relationship between privileges. For example, the auditing privilege **PV\_AU\_** is the parent of privileges **PV\_AU\_ADD**, **PV\_AU\_ADMIN**, **PV\_AU\_READ**, **PV\_AU\_WRITE** and **PV\_AU\_PROC**. When checking for privilege, the system first determines if the process has the lowest privilege needed and then proceeds up the hierarchy, checking for the presence of a more powerful privilege. The **PV\_ROOT** privilege is a special privilege that represents the parent of all privileges except **PV\_SU\_**. A process that is assigned the **PV\_ROOT** privilege behaves as if it has been assigned every privilege on the system except **PV\_SU\_**.

#### *Process privilege sets:*

Multiple sets of privileges are defined in the kernel to provide varied controls for privileged operations. Multiple privilege sets allow the operating system to enforce dynamic privilege controls and allow applications to manage least-privilege principles.

Privileges are associated with a process through the following privilege sets:

#### **Limiting Privilege Set (LPS)**

Defines the hard limit on privileges for a given process. No privilege escalation in the system can raise process privileges beyond this value. This means that a process cannot acquire any more privileges than this value using any of the defined system interfaces. In other words, the process is restricted to these privileges at any point in time. This also means that the rest of the privilege sets will always be subsets of LPS. Even though LPS cannot be expanded, every process will have the right to reduce the LPS. However, once the LPS is reduced, it cannot be expanded back to its original value. The lowering of the LPS allows a process to restrict the boundaries in regard to associated privileges. For example, a process might reduce the LPS just before running a custom user-provided program. By default, all of the privileges available on the system are set in the LPS for a process.

#### **Maximum Privilege Set (MPS)**

The full set of privileges that the process is authorized to use. The MPS can include any privilege in the LPS, but cannot exceed the LPS. The MPS can change during the lifetime of a process for many reasons. The following are some of the reasons:

- When the current process executes another privileged command and then gains related additional privileges
- If the process has the right privilege, then it can expand the MPS programmatically in a dynamic manner

#### **Effective Privilege Set (EPS)**

The list of privileges which are currently active for the process. The EPS is always a subset of the process' MPS and is used by the kernel to perform access checks in regard to privileged operations. The EPS can be manipulated by the process and can equal the MPS, but cannot exceed the MPS. Dynamic manipulation of the EPS can be performed by the process to enforce least-privilege principles. For example, user-space code can potentially raise the audit privilege bit

in the EPS using the **priv\_raise** API before making an audit-related system call or kernel call. The privilege can then be lowered with the **priv\_lower** API when the audit call returns.

### **Inheritable Privilege Set (IPS)**

Privileges which are passed from a parent process to its child processes' MPS and EPS. The IPS can include any privilege in the LPS, but cannot exceed the LPS. The IPS can be set in a process in the following ways:

- If the process has the proper privilege, it can expand the IPS programmatically through the **setpriv** system call
- When a privileged command is run, the privileges specified in the **inheritprivs** attribute that is associated with the command are assigned into the IPS.

### **Used Privilege Set (UPS)**

Denotes the privileges that have been used for access checks during the life of the process. The UPS can be used to determine the privileges required by the process. When the kernel checks if a process has a given privilege, it stores a successful check in the UPS for the privilege.

### **Workload Partition Privilege Set (WPS)**

A system WPAR can be restricted to not allow all of the privileged operations that are allowed in a global WPAR. The privileged operations allowed in a system WPAR can be controlled through the WPS. The global root can assign a limited set of privileges to a WPAR using WPS. The WPS can be specified in the **/etc/wpar/secattr** configuration file or during the start of a WPAR using the **/usr/sbin/startwpar** command. All processes running in a WPAR have their LPS equal to their WPS.

A system administrator can use administrative commands to list and modify the various privilege sets of a process. The **lssecattr** command can be used to list the LPS, MPS, EPS, IPS, and UPS. The **setsecattr** command can be used to modify the LPS, MPS, EPS, and IPS. The UPS cannot be modified with the **setsecattr** command since the UPS is a read-only attribute.

### ***Privileged command database:***

Authorizations, roles, and privileges allow granular security controls to be implemented. However, the exploitation of RBAC by various system operations allows an RBAC security policy to be enforced.

While historically some AIX commands directly checked for authorizations, it required that the executable code itself be modified to perform these checks. The enhanced RBAC mode provides a framework to enforce authorization checks and grant associated privileges through the privileged command database without requiring changes to system executables.

The privileged command database grants access and powers to users for commands they would not otherwise be able to run or for which they would not have the proper privilege to perform the task. The database saves the authorization information for a particular command as well as the privileges that are granted to the process if authorization checks succeed. When the database is stored locally, it exists in the **/etc/security/privcmds** file and contains stanzas of information in the form of command-versus-security attributes. The following are a few of the key attributes in this database (for a full description of all of the attributes, see the **/etc/security/privcmds** file).

#### **accessauths**

List of access authorizations that protect the execution of the command. A user with any one of the listed authorizations is allowed to run the command and perform some or all of the privileged operations that are contained in the command.

#### **innateprivs**

Innate privileges are privileges assigned to the process if the invoker succeeds the access authorization checks.

#### **authprivs**

Authorized privileges are additional privileges assigned to the process if the user has the

associated authorization. This attribute allows more granular control of the command to allow a restricted set of users to perform additional privileged operations.

### **inheritprivs**

Inheritable privileges are privileges that the process passes on to child processes.

### **secflags**

List of security flags. **FSF\_EPS** is a flag which causes the maximum privilege set (MPS) to be loaded into the effective privilege set (EPS) when the command is run.

When a user on an enhanced RBAC mode system attempts to run a command, the command is first checked in the privileged command database. If the command exists in the database, a check is performed against the authorizations associated with the user's session and the value of the **accessauths** attribute for the command. If the session has one of the authorizations listed, the user can run the command regardless of whether the user passes the DAC execution checks for the command. Upon invocation, the command process has the privileges listed in the **innateprivs** attribute assigned into its maximum privilege set (MPS). Additional authorization checks are performed with the authorization-privilege pairs listed in the **authprivs** attribute. If the session has one of the listed authorizations, the associated privilege(s) are also added to the MPS of the command process. A command entry in the privileged command database that has the **FSF\_EPS** value set in the **secflags** attribute assigns all of the privileges in the MPS to the effective privilege set (EPS) upon when the command is invoked.

A command is known as a privileged command when it is included in the privileged command database. While setuid programs that are not listed in the database are still technically privileged commands, they are not referred to as privileged commands when describing RBAC behavior. If a command does not have an entry in the privileged commands database, then it is not a privileged command and access to it is enforced by DAC and the command itself. Additionally, if a command is listed in the privileged command database, but the user's session does not have an authorization that allows invocation of the command, the system reverts to checking DAC access and allows the command to be run if these checks succeed.

Several management commands have been created to manipulate and query the privileged command database. Entries in the privileged command database can be created or modified with the **setsecattr** command, displayed with the **lssecattr** command, and removed with the **rmsecattr** command.

#### *Determining required privileges for a command:*

Many system administrative applications require privileges to run properly. While a set of predefined commands is provided in the privileged command database, a system administrator may need to add entries that are specific to their environment. The privileged command database allows entries to be added to the database and privileges to be associated with the invocation of the command.

Prior to adding a command to the privileged command database, the minimum set of required privileges must be determined to ensure that command execution is as secure as possible. Any privileges granted beyond those necessary for proper execution violate the least-privilege principle. Therefore, an important step in adding a privileged command to the system is determining the minimum required privileges.

The following is the basic strategy to determine the minimum required privileges for a command:

1. Assign the **PV\_ROOT** privilege to the invoking shell
2. Run the command
3. Record the privilege set used for the process
4. Store the necessary privileges in the **innateprivs** attribute of the command in the privileged command database

These steps should be performed in a controlled environment since the **PV\_ROOT** privilege is assigned to a shell and the **PV\_ROOT** privilege is extremely powerful. In addition, running the command may have

some system impact that can affect other users. In practice, this is likely to be a trial-and-error procedure. In order to obtain the full set of privileges, the command will likely need to be run repeatedly with different flags and options, and possibly for a long period of time for long-running applications. The required privilege set of the process can be easily gathered using one of the following procedures, which can be performed by an administrator with proper authority:

#### **tracepriv**

Takes an argument that is the command to execute. The **tracepriv** command runs the command and records the privileges used during the lifetime of the process. When the command finishes, the **tracepriv** command displays the privileges that were used on **stdout**.

#### **lssecattr**

If the command is a long-running process, the **lssecattr** command can be used to display the privileges used by the process. To display the used privilege set for a process, run the command as follows, substituting the PID of the process that is being monitored:

```
lssecattr -p -a uprivs PID
```

After the minimum required privileges have been determined, perform the steps in “Adding a command to the privileged command database” to add the command to the privileged command database. The command should then be run by an authorized user to verify that it runs properly.

#### *Privilege escalation:*

When a new process is created by the **fork** system call, **fork** grants the process the same privileges as the parent process (the process that called the **fork** system call). When a process does an **exec** system call on an executable file, **exec** recalculates the privileges for the executable file based on the privileges that **exec** currently possesses and the privileges possessed by the executable file.

Escalated privileges are calculated as follows:

1. First, the union (bitwise-OR operation) of inheritable privileges possessed by the old (parent) process and the set of innate privileges possessed by the executable file is calculated.
2. If the user is appropriately authorized, the union (bitwise-OR) of the result from the previous step and the authorized privileges is calculated.
3. If the limiting privileges exist, then the intersection of the result from the previous step and the limiting privileges is calculated. Limiting privileges, if any, are inherited across an **exec** system call.
4. The set of privileges resulting from that union become the set of maximum privileges for the new process.
5. If the inherited privileges exist in the executable file, they are assigned to inheritable privileges set in the new process. Otherwise, the set of inheritable privileges possessed by the old (parent) process is carried forward in the new process’s inheritable privilege set.

If the executable file has its **FSF\_EPS** file security flag set, the set of effective privileges for the new process is the same as its set of maximum privileges. Otherwise, the effective privileges for the new process are same as the inheritable privileges possessed by the old (parent) process.

#### *Adding a command to the privileged command database:*

You should consider carefully before adding a command to the privileged command database to ensure that the proper authorizations and privileges are assigned.

See the **/etc/security/privcmds** file for a full description of the attributes that are valid for a command. The following questions can be used as a guide to determine the entry required for a command:

1. Should an authorization control access to run the command?

**YES** If the authorization does not exist, create it with the **mkauth** command. Specify the authorization in the **accessauths** attribute.

- NO** If all users should be allowed to run the command, specify the **ALLOW\_ALL** authorization in the **accessauths** attribute.
2. Should the owner or group of the command be allowed to run the command even if they do not have the proper authorization?
- YES** Add the **ALLOW\_OWNER** or **ALLOW\_GROUP** authorization to the list of authorizations in the **accessauths** attribute.
3. When the command is executed, does it require an explicit set of privileges?
- YES** Run the command with various options as the root user with the **tracepriv** command to determine the required privileges for the **innateprivs** attribute.
4. Should users with a specific authorization be granted additional privileges?
- YES** Specify the additional authorization-privilege pairs in the **authprivs** attribute.
5. Does the command need to behave like a SUID or SGID program?
- YES** Specify the EUID or EGID as appropriate.
6. Do privileges assigned to the command need to be passed on to child processes?
- YES** Specify the privileges in the **inheritprivs** attribute.
7. Should the effective privilege set of the command be equal to the maximum privilege set at the time the command is invoked?
- YES** Specify the **FSF\_EPS** flag for the **secflags** attribute.
- NO** Do not specify the **secflags** attribute. The command code is expected to raise and lower its privileges as required when the **FSF\_EPS** flag is not specified.

After answering these questions, run the **setsecattr** command with the appropriate parameters to add the command to the database. If the command is an existing command and is an SUID or SGID command, then consideration should be given to remove the **SUID** and **SGID** bits from the file so that the least-privilege model is enforced.

### ***Privileged device database:***

The privileged device database stores the list of privileges that are allowed to read from or write to a device. This database provides a mechanism for an administrator to further control access to a device than can be managed through traditional device access controls.

When this database is stored locally, it is contained in the **/etc/security/privdevs** file. The database stores the privileges required to access a given device for read or write operations in the following attributes:

#### **readprivs**

Lists privileges which are allowed to read from the device

#### **writeprivs**

Lists privileges which are allowed to write to the device

When a privileged device is requested to be opened in read mode, the open is only allowed if one of the privileges specified in the **readprivs** attribute exists in the effective privilege set (EPS) for the process. Similarly, if the device is opened for write mode, a privilege in the **writeprivs** attribute must exist in the EPS.

The process of adding a device to the privileged device database is normally not a common operation. The **lssecattr** and **setsecattr** commands can be used to list and manipulate the database, but adding or modifying entries in the database requires considerable investigation. Since the read and write permission for a device is controlled through privileges, a thorough investigation of the commands and applications that need to access the device must be performed to ensure that the proper privileges are specified.



### ***Privileged file database:***

Many system configuration files in traditional UNIX systems are owned by the root user and are not directly modifiable by other users. RBAC allows a user to modify these system configuration files by activating a role and running a command to gain the privileges needed to modify the file.

There are some AIX configuration files that do not have command interfaces to allow modification of the file. In these cases, it is necessary to have a tool that allows an administrator with the appropriate authorization to directly edit and save a file to which they otherwise would not have access.

The privileged file database provides a method to use authorizations to determine access to system configuration files. When the database is stored locally, it is contained in the **/etc/security/privfiles** file. This database maps configuration files to the authorizations required to view or modify these files. Access to a configuration file is controlled in this database with the following attributes:

#### **readauths**

List of authorizations allowed to read from the file

#### **writeauths**

List of authorizations allowed to write to the file (read authorization is implied in this case)

Entries in the privileged file database can be listed with the **lssecattr** command and can be created or modified with the **setsecattr** command. Files defined in the privileged file database can be accessed by authorized users with the **/usr/bin/pvi** command. The **pvi** command is a privileged and restricted version of the **vi** editor based on the **/usr/bin/tvi** command. The **pvi** command imposes all of the same security precautions as the **tvi** command (for example, no **-r** or **-t** flags, no shell escapes, no user defined macros) and also enforces the following restrictions:

- The system must be in Enhanced RBAC Mode.
- Only files defined in the privileged file database can be opened.
- Only one file can be opened at a time.
- Writing to a different filename than the one specified on the command line is disabled.
- The **/etc/security/privfiles** file cannot be edited with the **pvi** command.
- Attempts to open links will fail. Only regular files can be edited.

The authorization checks are performed prior to opening the file. If the authorization matches, the privilege set of the process is raised to include **PV\_DAC\_R** or **PV\_DAC\_W** (depending on whether the file is being opened for reading or writing). If the authorization does not match, an error message is displayed and the user is denied access to the file with the **pvi** command.

### ***Kernel security tables:***

The information contained in the authorization, role, privileged command, and privileged device databases is not used for security considerations until the data has been loaded into an area of the kernel designated as the kernel security tables (KST). In the enhanced RBAC mode, authorization and privilege checks are performed in the kernel, so the databases must be sent to the kernel before they can be used.

The KST is composed of the following sub-tables:

- Kernel Authorization Table (KAT)
- Kernel Role Table (KRT)
- Kernel Command Table (KCT)
- Kernel Device Table (KDT)

All of the tables or select tables can be sent to the kernel from the user space with the **setkst** command. The KRT and KCT are dependent on the KAT, so if the KAT is selected to be updated, the KRT and KCT are also updated to verify that the tables are in sync. The preferred method for adding updates to the KST

is to create or modify all of the necessary databases at the user level (with commands such as **mkauth**, **chauth**, **mkrole**, and **setsecattr**) and then use the **setkst** command to send the tables to the kernel. Once the tables have been loaded in the kernel, the **lskst** command can be used to display the information contained in each table.

A given table in the KST is always sent as a complete table. In other words, the KST does not allow for individual entry modifications; the entire table must be replaced. Prior to sending the tables to the kernel, the **setkst** command validates the tables and the relationships between them. The **setkst** command is also placed in the **inittab** file to ensure that the databases are sent to the KST early in the boot process.

If for some reason the tables cannot be created or cannot be loaded into the kernel and no tables have previously been loaded, the system operates as if there are no authorizations or roles. Commands, APIs, and system calls for authorization and role checking return failure in this scenario since no match is found. System operation in this state is very similar to the legacy RBAC mode, except that no user can access sections of code in commands that enforce authorizations.

### ***Disabling the root user:***

In enhanced RBAC mode, it is possible to configure the system so that the root user has no associated special powers and is treated by the system as a normal user.

Historically, the root user's ID value of 0 has been treated as a privileged ID by the operating system and is allowed to bypass enforced security checks. Disabling the root user effectively removes the checks in the operating system which allow the user ID of 0 to bypass security checks and instead requires the process to have privileges to pass the security checks. Disabling the root user minimizes the damage an attacker can cause since there is no longer a single all-powerful user identity on the system. After disabling the root user, system administration must be performed by users who have been assigned privileged roles.

The root powers can be disabled with the **/usr/sbin/setsecconf** command. Run the following command and then reboot the system to disable the powers of the root user:

```
setsecconf -o root=disable
```

After running this command the root user account cannot be accessed through remote or local login or through the **su** command. However, since the root user account remains the owner of files on the file system, if the account is acquired, the user would have access to privileged files.

On a system where root has been disabled, processes owned by root are no longer assigned any special powers or privileges. This should be considered if the system has **setuid** applications owned by root that have not been added to the privileged command database. These **setuid** applications will probably fail in a root-disabled environment since the process cannot perform privileged operations. In a root-disabled system, any command that needs to perform privileged operations should be added to the privileged command database and assigned the appropriate privileges. Therefore, a careful analysis of the system and the applications used on the system should be performed before disabling the powers of the root user.

### ***Remote RBAC database support:***

In an enterprise environment, it is desirable to be able to implement and enforce a common security policy across all systems in the environment. If the databases that control the policy are stored independently on each system, management of the security policy becomes a burden for the designated system administrator. AIX enhanced RBAC mode allows the RBAC databases to be stored in LDAP so that the security policy for all systems in the environment can be centrally managed.

Support has been added in AIX for all of the RBAC-relevant databases to be stored in LDAP. The following are the relevant RBAC databases:

- Authorization database

- Role database
- Privileged command database
- Privileged device database
- Privileged file database

**Note:** The authorization database stored in LDAP contains only the user-defined authorizations. System-defined authorizations cannot be stored in LDAP and remain local to each client system.

AIX provides utilities to easily export local RBAC data to LDAP, to configure the client to use RBAC data in LDAP, to control the lookup of RBAC data, and to manage the LDAP data from a client system. The following sections provide more information on the LDAP features that are provided in enhanced RBAC.

#### *Exporting RBAC data to LDAP:*

Initial preparation for using LDAP as an RBAC database repository requires populating the LDAP server with the RBAC data.

The LDAP server must have the RBAC schema for LDAP installed on it before LDAP clients can use the server for RBAC data. The RBAC schema for LDAP is available on an AIX system in the **/etc/security/ldap/sec.ldif** file. The schema of the LDAP server should be updated with this file by using the **ldapmodify** command.

The **/usr/sbin/rbactoldif** file can be used to read the data in the local RBAC databases and output them in a format suitable for LDAP. The output generated by the **rbactoldif** command can be saved to a file and then used to populate the LDAP server with the data with the **ldapadd** command. The following databases on the local system are used by the **rbactoldif** command to generate the RBAC data for LDAP:

- **/etc/security/authorizations**
- **/etc/security/privcmds**
- **/etc/security/privdevs**
- **/etc/security/privfiles**
- **/etc/security/roles**

The LDAP storage location for the RBAC data should be given some consideration. It is recommended that the RBAC data in LDAP be placed under the same parent DN as the user and group data. The ACLs on the data should then be adjusted as needed for the chosen security policy.

#### *LDAP client configuration for RBAC:*

A system must be configured as an LDAP client to use RBAC data stored in LDAP.

You can use the AIX **/usr/sbin/mksecldap** command to configure a system as an LDAP client. The **mksecldap** command dynamically searches the specified LDAP server to determine the location of the authorization, role, privileged command, device, and file data, and saves the results to the **/etc/security/ldap/ldap.cfg** file.

After successfully configuring the system as an LDAP client with the **mksecldap** command, the system must be further configured to enable LDAP as a lookup domain for RBAC data. The **/etc/nscontrol.conf** file must be modified to include LDAP in the **secorder** attribute for databases that are stored in LDAP.

Once the system has been configured as both an LDAP client and as a lookup domain for RBAC data, the **/usr/sbin/secldapclntd** client daemon periodically retrieves the RBAC data from LDAP and sends the data to the Kernel Security Tables (KST) with the **setkst** command. You can configure the time period used by the daemon to retrieve the RBAC data from LDAP with the **rbacinterval** attribute in the

**/etc/security/ldap/ldap.cfg** file. The default value of this attribute is 3600, which specifies to retrieve the RBAC data from LDAP and update the KST once every hour. The KST can also be manually updated when an administrator runs the **setkst** command.

*Name service control file:*

The RBAC data can reside strictly in local files, strictly in LDAP, or can be merged in local files and LDAP by configuring a given database in the **/etc/nscontrol.conf** name service control file.

The search order for the authorization, role, privileged command, device, and file databases is specified individually in the **/etc/nscontrol.conf** file. The search order for a database is specified in the file with the **secorder** attribute, which is a comma-separated list of domains. The following is an example of a configuration for the authorization database:

```
authorizations:
 secorder = LDAP,files
```

This example specifies that queries on authorizations should search in LDAP first and then in the local files if the authorization is not found in LDAP. The collection of authorizations available to the system is the merge of the authorizations provided by LDAP and those provided in the local files. The merge is not a simple combination of the values from the two domains, but rather a union of the values. For the configuration above, all LDAP authorizations are included and then only unique authorizations from local files are added to the result.

Modifications and deletions are attempted on the first domain listed and are only attempted on subsequent domains if the entity is not found in the first domain. In this case, LDAP is attempted first and local files are only attempted if the authorization is not found in LDAP. New entries are always created in the first domain listed in the **secorder** attribute. In the example above, a creation of a new authorization occurs in the LDAP database.

If there is no entry for a database in the **/etc/nscontrol.conf** file or if the file does not exist, queries and modifications on the database are only performed in the local files database. The configuration for a database in the file can be set with the **chsec** command and listed through the **lssec** command. To configure authorization data to be retrieved from LDAP first and then from the local files, run the following command:

```
chsec -f /etc/nscontrol.conf -s authorizations -a secorder=LDAP,files
```

The configuration in the **/etc/nscontrol.conf** file controls both the library and command line interfaces. Applications can retrieve the current value of the **secorder** attribute for a database with the **getsecorder** interface. The value of the **secorder** attribute can be overridden for the process with the **setsecorder** interface.

*RBAC command enablement for LDAP:*

All of the RBAC database management commands are enabled to use the configuration in the **/etc/nscontrol.conf** file and to query, modify, create, or remove the entity in the domain or domains defined for a given database.

By default, the domains are processed as defined in the **secorder** attribute for a database, but this can be overridden by using the **-R** option on the command line. Specifying the **-R** option for a command forces the operation to occur on the specified domain and overrides the configuration in the **/etc/nscontrol.conf** file. The following RBAC database management commands are enabled for remote domain support:

- **mkauth**, **chauth**, **lsauth**, and **rmauth**
- **mkrole**, **chrole**, **lsrole**, and **rmrole**
- **setsecattr**, **lssecattr**, and **rmsecattr**

In addition, the **setkst** command is enabled to use the configuration contained in the **/etc/nscontrol.conf** file. The **setkst** command retrieves a merged copy of the entries for a given database as defined in the file and then loads the resulting data into the Kernel Security Tables.

#### *Cross-domain assignment:*

When designing an environment where RBAC data is provided by two domains such as local files and LDAP, consideration must be given to the issue of cross-domain assignment of entities. Examples of cross-domain assignment include assigning an LDAP-defined role to a local user or assigning a local-defined role to an LDAP user.

The assignment of a remote entity (LDAP role) to a local entity (local user) is not much of a concern since it has no impact on other systems in the environment. However, assigning a local entity (local role) to a remote entity (LDAP user) should only be done with great care. Since the remote entity (LDAP user) is visible on multiple clients, there is no guarantee that the local entity (local role) assigned to it is defined or has the same definition on each client system. For example, a role may be defined locally on each client but have different associated authorizations. A remote user that is assigned this local role would therefore have different authorizations on each of these clients and this can have undesirable security consequences.

To prevent possible security issues with assigning a local entity to LDAP entity, it is recommended that the LDAP server implement access control to the RBAC databases to prevent each client from modifying entries. Only clients connecting to the LDAP server through a privileged account should be allowed to modify LDAP RBAC entities. Other clients should only have read access to the LDAP RBAC databases.

#### **Size limits in enhanced RBAC:**

The following table lists the various limits for the RBAC-related elements:

*Table 10.*

| <b>Description</b>                                  | <b>Maximum size</b>     |
|-----------------------------------------------------|-------------------------|
| Role name                                           | 63 printable characters |
| Maximum roles per session                           | 8                       |
| Maximum authorization name size                     | 63 printable characters |
| Maximum number of levels in authorization hierarchy | 9                       |
| Maximum number of access authorizations per command | 8                       |
| Maximum authorized privileged sets per command      | 8                       |

#### **Administering enhanced RBAC:**

This section describes common command line usage scenarios for administering RBAC. These examples illustrate major aspects of the functionality. SMIT interfaces are also provided for RBAC administration. The fastpath to RBAC SMIT menus is `smit rbac`.

#### *Creating a user-defined authorization:*

You can create user-defined authorizations that can be used to control execution of commands.

You can use the `mkauth` command to create user-defined authorizations. Changes to the authorization database are effective after the changes are downloaded to the kernel with the **setkst** command.

- Run the following command to create a user-defined authorization:

```
mkauth auth_name
```

### *Creating and modifying roles:*

You can create a role with the **mkrole** command.

Roles are created with the **mkrole** command. Changes to the roles database are effective after they are downloaded to the kernel with the **setkst** command. You can modify roles with the **chrole** command.

- Run the following command to create a role:

```
mkrole dflt_msg="My Role" role_name
```

- To create a role and inherit the authorizations from existing roles, run the following command:

```
mkrole roletlist=child_role1,child_role2 role_name
```

- To modify a role definition, run the following command:

```
chrole roletlist=child_role3 role_name
```

### *Assigning authorizations to roles:*

You can use the **mkrole** or **chrole** commands to assign authorizations to a role.

- Run the **mkrole** command to assign the **auth\_name1** and **auth\_name2** authorizations to the **role\_name** role:

```
mkrole authorizations=auth_name1,auth_name2 role_name
```

- Run the **chrole** command to assign the **auth\_name1** and **auth\_name2** authorizations to the **role\_name** role:

```
chrole authorizations=auth_name1,auth_name2 role_name
```

### *Setting the authentication mode for a role:*

You can control the activation of roles with the role's **auth\_mode** attribute.

Valid values for the **auth\_mode** attribute are:

**NONE** No authentication necessary

#### **INVOKER**

Invokers must enter their own password. This is the default.

Enter the following command to force users to authenticate as themselves when assuming a given role:

```
chrole auth_mod=INVOKER role_name
```

### *Assigning roles to a user:*

You can use the **chuser** command to assign roles to users.

Run the following command to assign the **role\_name1** and **role\_name2** roles to the user **user\_name**:

```
chuser roles=role_name1,role_name2 user_name
```

### *Activating roles:*

By default, a user must activate the role in the session in order to execute privileged commands.

- To activate the **role\_name1** and **role\_name2** roles, run the following command:

```
swrole role_name1,role_name2
```

- Some of the roles that are assigned to users are classified as default roles. These roles are activated automatically when the user logs in. These roles are active during the entire login session. To assign **role\_name1** as a default role for a user, run the following command:

```
chuser roles=role_name1,role_name2 default_roles=role_name1 user_name
```

### *Listing the active role set:*

You can use the **rolelist** command with the **-e** option to display information about the effective active role set for a session.

- To display the effective active role set for a session, run the following command:

```
rolelist -e
```

### *Listing the roles for a user:*

The **rolelist** command provides role and authorization information about a user's current roles or the roles that have been assigned to them.

By default, the **rolelist** command displays the list of roles that have been assigned to the user. This is basically the same information displayed by the `lsuser -a roles user1` command except that it also includes the text description of the role if one has been provided.

- To list your assigned roles and associated authorizations, run the following command:

```
rolelist -a
```

### *Auditing session roles:*

The roles that are active in a login session are audited along with other attributes such as UID and GID. You can list these roles with the **auditpr** command.

To display the roles from the audit trail, run the following command:

```
auditpr -h eli -i /audit/trail
```

### *Assigning privileges to a running process:*

You can use the **setsecattr** command to modify the privileges of a running process.

- To update the effective privilege set associated with a process, run the following command:  
**setsecattr -p eprivs=privileges pid**
- Before adding any privilege to the effective privilege set of a process, you should ensure that the privilege already exists in the maximum privilege set. To modify maximum privilege set, run the following command:

```
setsecattr -p mprivs=privileges pid
```

### *Administering WPAR privileges:*

Each WPAR is associated with a set of privileges that determine its powers. This is referred to as WPAR privilege set (WPS).

Processes running within a given WPAR can use only those privileges that are available in the WPS.

- To modify the WPS from the global WPAR, run the following command:

```
chwpar -S privs+=privileges wpar_name
```

### *Determining the privileges required for a command:*

Some commands require special privileges to perform privileged operations. Privileges are used in the kernel to bypass security restrictions.

You can use the **tracepriv** command to profile a command to determine the privileges that are required for the command to run successfully. The **tracepriv** command records the privileges that are used by another

command when the command is run. The command should be run with the **PV\_ROOT** privilege so that any attempts to use privileges will succeed. When the command completes, the set of privileges that have been used are sent to **stdout**.

- To profile a given command, run the following command:

```
tracepriv -ef command_name
```

#### *Using authorizations to control commands:*

Authorizations can be used to control the running of commands.

You can use the **setsecattr** command to associate authorizations with a command. The **setsecattr** command adds a stanza to the privileged commands database (**/etc/security/privcmds**). Modifications to this database must be downloaded to the kernel with the **setkst** command.

- To associate authorizations with a command, run the following command:

```
setsecattr -c accessauths=auth_names innateprivs=privileges proxyprivs=privileges
authprivs=auth_name=privileges command_name
```

#### *Controlling access to devices:*

RBAC provides a mechanism to further control access to devices. A system administrator can specify the privileges that are required to open a device in read mode or write mode.

For example, write access to a DVD writer can be controlled with the **PV\_DEV\_CONFIG** privilege so that only processes which have this privilege can create DVDs.

- To add a device to the device database, run the following command:

```
setsecattr -d readprivs=privileges writeprivs=privileges device_name
```

#### *Updating RBAC Kernel Security Tables:*

The **setkst** command reads the security databases and loads the information from the databases in the Kernel Security Tables (KST).

By default, all of the security databases are sent to the KST. Alternatively, a specific database can be specified with the **-t** option. However, specifying that only the authorization database should be sent to the KST also updates the role and privileged command databases in the KST since the role and privileged command database are dependent on the authorization database.

- To send all the latest RBAC databases to the kernel, run the following command:

```
setkst
```

#### *Using the enhanced RBAC mode switch:*

A system-wide configuration switch is provided to disable the enhanced RBAC capabilities and revert to legacy RBAC behavior.

A system administrator can disable enhanced RBAC mode by running the **chdev** command on the **sys0** device and specifying the **enhanced\_RBAC** attribute with a value of **false** and then rebooting the system. The mode can be switched back to enhanced RBAC mode by setting the **enhanced\_RBAC** attribute to **true** and then rebooting the system.

- To revert to legacy RBAC mode, run the following command:

```
chdev -l sys0 -a enhanced_RBAC=false
```

- To list the value of the **enhanced\_RBAC** attribute, run the following command:

```
lsattr -E -l sys0 -a enhanced_RBAC
```



In a WPAR environment, the RBAC mode can only be configured from the global system and affects the global as well as all WPARs.

**Note:** Disabling the enhanced RBAC mode may lower the security threshold of your system, especially in a WPAR.

## RBAC-related commands

The following table lists the RBAC-related commands that are provided in AIX to manage and use the RBAC framework.

| Command           | Description                                                                     |
|-------------------|---------------------------------------------------------------------------------|
| <b>ckauth</b>     | Check the current process for an authorization                                  |
| <b>chauth</b>     | Modify user-defined authorization attributes                                    |
| <b>lsauth</b>     | Display user- and system-defined authorization attributes                       |
| <b>mkauth</b>     | Create a new user-defined authorization                                         |
| <b>rmauth</b>     | Remove user-defined authorizations                                              |
| <b>chrole</b>     | Modify role attributes                                                          |
| <b>lsrole</b>     | Display role attributes                                                         |
| <b>mkrole</b>     | Create a new role                                                               |
| <b>rmrole</b>     | Remove a role                                                                   |
| <b>rolelist</b>   | Display role information for a user or process                                  |
| <b>swrole</b>     | Create a new role session                                                       |
| <b>lssecattr</b>  | Display security attributes of a command, device, process, or file              |
| <b>rmsecattr</b>  | Remove the definition of security attributes for a command, device, or file     |
| <b>setsecattr</b> | Set the security attributes of a command, device, process, or file              |
| <b>lskst</b>      | List the entries in the Kernel Security Tables                                  |
| <b>setkst</b>     | Send the entries in the RBAC user-level databases to the Kernel Security Tables |
| <b>lspriv</b>     | Display the privileges available on the system                                  |
| <b>tracepriv</b>  | Trace the privileges needed by a command to successfully run                    |
| <b>pvi</b>        | Privileged file editor                                                          |
| <b>rbactoldif</b> | Output RBAC user-level databases in LDAP-compatible format                      |
| <b>setseconf</b>  | Modify kernel security flags                                                    |

## RBAC-related files

The following table lists the RBAC-related files provided in AIX to configure and store database information.

| File                                | Description                                              |
|-------------------------------------|----------------------------------------------------------|
| <b>/etc/nscontrol.conf</b>          | Name service control file for certain security databases |
| <b>/etc/security/authorizations</b> | User-defined authorization database                      |
| <b>/etc/security/privcmds</b>       | Privileged command database                              |

| File                                 | Description                |
|--------------------------------------|----------------------------|
| <code>/etc/security/privfiles</code> | Privileged file database   |
| <code>/etc/security/privdevs</code>  | Privileged device database |
| <code>/etc/security/roles</code>     | Role database              |

## Using enhanced RBAC in applications

Many applications do not require any modifications to run successfully in the enhanced RBAC environment. Simply defining the application's access authorizations and associated privileges and then assigning the application to the privileged command database may be sufficient.

However, an application can use enhanced RBAC by calling RBAC interfaces to control the application's execution at a granular level and thereby result in a more secure application. Applications that might benefit from integration with enhanced RBAC include the following:

- Applications that restrict use to either the root user or members of a specific group. These applications typically check for effective user identity or group membership and can be modified to check for an authorization instead.
- Applications that utilize **setuid** or **setgid** mode bits to allow unprivileged users to gain privileges during the command invocation. These applications would usually be more secure by using privilege bracketing so that less privilege is used to accomplish their task.

### **Authorization checking:**

Applications that currently use the user ID or group ID of the invoking user to determine the ability to perform privileged operations should be modified to check for an authorization instead.

For example, consider an application which performs filesystem configuration tasks and currently allows the root user (UID = 0) to perform some privileged operations:

```
if (getuid() == 0) {
 /* allow privileged operation to continue */
}
```

To enable this application to instead allow users with a specific authorization (**aix.fs.config**) to perform the privileged operation, the code can be modified to use the **checkauths** API to perform the authorization check:

```
if (checkauths("aix.fs.config", CHECK_ALL)) {
 /* allow privileged operation to continue */
}
```

The **checkauths** API is enabled for both the legacy and enhanced RBAC modes and will return a **0** success code if the invoking process has the specified authorization. The **checkauths** API also determines if the root user powers are enabled or disabled and then allows or disallows the root user to bypass authorization checks as appropriate. Prior to AIX Version 6.1, the **MatchAllAuths**, **MatchAnyAuths**, **MatchAllAuthsList**, and **MatchAnyAuthsList** APIs were normally used to perform authorization checks. Applications provided on AIX Version 6.1 and later should use the **checkauths** API instead due to its support for legacy and enhanced RBAC modes and root disablement.

As in the example above, applications that call **getuid**, **getgid**, or a similar function to only allow certain users to perform specific tasks can be modified to use the **checkauths** API to perform an authorization check instead. If the user ID or group ID being checked is not that of the root user, the **sys\_parm** system call can be used first to query whether enhanced RBAC is enabled or not. If enhanced RBAC is not enabled, the code can perform the checks that are already in place. Otherwise, if enhanced RBAC is enabled, the code can check for the relevant system or user-defined authorizations.

### **Privilege bracketing:**

Once applications have been modified to check for authorizations, they can be further modified to utilize fine-grained privilege bracketing during operation.

Applications can use the **priv\_raise** API to raise the privileges required to perform an operation and lower the privilege with the **priv\_lower** API. Raising privileges immediately before a privileged operation is attempted and lowering privileges after the operation has completed is known as privileged bracketing and is the preferred method for applications to use privileges. To raise a privilege, the privilege needs to be available in the maximum privilege set of the application in the privileged commands database. Raising a privilege causes the privilege to be placed in the effective privilege set (EPS) of the process. Lowering a privilege removes the privilege from the EPS. The following code sample shows privilege bracketing around the **auditproc** API.

```
priv_raise(PV_AU_ADMIN, -1); /* raise privilege when needed */
auditproc(); /* call auditing system call */
priv_lower(PV_AU_ADMIN, -1); /* lower privilege */
```

### ***RBAC-aware applications:***

Traditionally, in AIX and on root-enabled enhanced RBAC systems, a root or root-owned **setuid** program (with UID=0) that does not appear in the privileged command database is always granted all privileges in the kernel. Privilege checks in the kernel will therefore always return success even when a requested privilege is not present in the process effective privilege set (EPS).

This behavior is still needed to support existing **setuid** applications, but this can be a security risk because a **setuid** program will have all of the powers of root.

To allow proper privilege bracketing in a process on a root-enabled enhanced RBAC system, a new bit in the process structure has been introduced. If this bit is set, then the process becomes an RBAC-aware process and an effective UID of 0 does not provide any extra privileges. This bit can be set in a program with the **proc\_rbac\_op** system call. Any **setuid** programs which are not listed in the privileged command database can use this functionality to reduce security vulnerability by lowering the available privileges. Note that programs that are defined in the privileged command database are automatically marked as RBAC-aware processes and are only assigned the privileges listed in the database.

The following code demonstrates how an application can mark itself as RBAC-aware and then perform proper privilege bracketing:

```
#include <userpriv.h>
#include <sys/priv.h>

privg_t effpriv;

int rbac_flags = SEC_RBACAWARE;

/* Mark the process as RBAC-aware. */
proc_rbac_op(-1, PROC_RBAC_SET, &rbac_flags);

/* Set the effective privilege set as empty. */
priv_clrall(effpriv);
setppriv(-1, &effpriv, NULL, NULL, NULL);

/* Raise privilege when required. */
priv_raise(PV_AU_ADMIN, -1);
auditproc();

/* Lower privilege when no longer needed. */
priv_lower(PV_AU_ADMIN, -1);
```

### ***RBAC APIs:***

The RBAC-related APIs available on the system are listed in the following table. Please see the specific APIs for more information.

| API                                                                | Description                                                                                              |
|--------------------------------------------------------------------|----------------------------------------------------------------------------------------------------------|
| checkauths                                                         | Compares the passed in list of authorizations to the authorizations associated with the current process. |
| GetUserAuths                                                       | Retrieves the set of authorizations assigned to the current process.                                     |
| MatchAllAuths, MatchAllAuthsList, MatchAnyAuths, MatchAnyAuthsList | Compares authorizations. The checkauths API is preferred to these APIs.                                  |
| getauthattr, putauthattr                                           | Queries or modifies authorizations defined in the authorization database.                                |
| getauthattrs                                                       | Retrieves multiple authorization attributes from the authorization database.                             |
| putauthattrs                                                       | Updates multiple authorization attributes in the authorization database.                                 |
| getcmdattr, putcmdattr                                             | Queries or modifies the command security information in the privileged command database.                 |
| getcmdattrs                                                        | Retrieves multiple command attributes from the privileged command database.                              |
| putcmdattrs                                                        | Updates multiple command attributes in the privileged command database.                                  |
| getdevattr, putdevattr                                             | Queries or modifies the device security information in the privileged device database.                   |
| getdevattrs                                                        | Retrieves multiple device attributes from the privileged device database.                                |
| putdevattrs                                                        | Updates multiple device attributes in the privileged device database.                                    |
| getpfileattr, putpfileattr                                         | Queries or modifies the file security information in the privileged file database                        |
| getpfileattrs                                                      | Retrieves multiple file attributes from the privileged file database.                                    |
| putpfileattrs                                                      | Updates multiple file attributes in the privileged file database.                                        |
| getroleattr, putroleattr                                           | Queries or modifies roles defined in the role database.                                                  |
| getroleattrs                                                       | Retrieves multiple role attributes from the role database.                                               |
| putroleattrs                                                       | Updates multiple role attributes in the role database.                                                   |
| getsecorder                                                        | Retrieves the ordering of domains for certain security databases.                                        |
| setsecorder                                                        | Sets the ordering of domains for certain security databases.                                             |

## AIX privileges

The privileges that are available in AIX are listed in the following table. A description of each privilege and its related system calls is provided. Some privileges form a hierarchy where one privilege can grant all of the rights that are associated with another privilege.

When checking for privileges, the system first determines if the process has the lowest privilege needed, and then proceeds up the hierarchy checking for the presence of a more powerful privilege. For example, a process with the **PV\_AU\_** privilege automatically has the **PV\_AU\_ADMIN**, **PV\_AU\_ADD**,

**PV\_AU\_PROC**, **PV\_AU\_READ**, and **PV\_AU\_WRITE** privileges, and a process with the **PV\_ROOT** privilege automatically has all of the privileges listed below except for the **PV\_SU\_** privileges.

| Privilege   | Description                                                                                                           | System call reference                                                                                                           |
|-------------|-----------------------------------------------------------------------------------------------------------------------|---------------------------------------------------------------------------------------------------------------------------------|
| PV_ROOT     | Grants a process the equivalent of all privileges listed below except PV_SU_ (and the privileges it dominates)        |                                                                                                                                 |
| PV_AU_ADD   | Allows a process to record/add an audit record                                                                        | auditlog                                                                                                                        |
| PV_AU_ADMIN | Allows a process to configure and query the audit system                                                              | audit, auditbin, auditevents, auditobj                                                                                          |
| PV_AU_PROC  | Allows a process to get or set an audit state of a process                                                            | auditproc                                                                                                                       |
| PV_AU_READ  | Allows a process to read a file marked as an audit file in Trusted AIX                                                |                                                                                                                                 |
| PV_AU_WRITE | Allows a process to write or delete a file marked as an audit file, or to mark a file as an audit file in Trusted AIX |                                                                                                                                 |
| PV_AU_      | Equivalent to all above auditing privileges (PV_AU_*) combined                                                        |                                                                                                                                 |
| PV_AZ_ADMIN | Allows a process to modify the kernel security tables                                                                 | sec_setkst                                                                                                                      |
| PV_AZ_READ  | Allows a process to retrieve the kernel security tables                                                               | sec_getkat, sec_getkpct, sec_getkpkt, sec_getkrt, etc.                                                                          |
| PV_AZ_ROOT  | Causes a process to pass authorization checks during exec() (used for inheritance purposes)                           |                                                                                                                                 |
| PV_AZ_CHECK | Causes a process to pass all authorization checks                                                                     | sec_checkauth                                                                                                                   |
| PV_DAC_R    | Allows a process to override DAC read restrictions                                                                    | access, creat, accessx, open, read, faccessx, mkdir, getea, rename, statx, _sched_getparam, _sched_getscheduler, statea, listea |
| PV_DAC_W    | Allows a process to override DAC write restrictions                                                                   | Many of the above and setea, write, symlink, _setpri, _sched_setparam, _sched_setscheduler, fsetea, rmdir, removeea             |
| PV_DAC_X    | Allows a process to override DAC execute restrictions                                                                 | Many of the above and execve, symlink, rmdir, chdir, fchdir, ra_execve                                                          |
| PV_DAC_O    | Allows a process to override DAC ownership restrictions                                                               | chmod, utimes, setacl, revoke, mprotect                                                                                         |
| PV_DAC_UID  | Allows a process to change its user ID                                                                                | setuid, seteuid, setuidx, setreuid, ptrace64                                                                                    |
| PV_DAC_GID  | Allows a process to set a new or change its group ID                                                                  | setgid, setgidx, setgroups, ptrace64                                                                                            |
| PV_DAC_RID  | Allows a process to set a new or change its role ID                                                                   | setroles, getroles                                                                                                              |
| PV_DAC_     | Equivalent to all above DAC privileges (PV_DAC_*) combined                                                            |                                                                                                                                 |

| Privilege     | Description                                                                                     | System call reference                                                                                                                                          |
|---------------|-------------------------------------------------------------------------------------------------|----------------------------------------------------------------------------------------------------------------------------------------------------------------|
| PV_FS_MOUNT   | Allows a process to mount and unmount a filesystem                                              | vmount, umount                                                                                                                                                 |
| PV_FS_MKNOD   | Allows a process to create a file of any type or to perform the mknod system call               | mknod                                                                                                                                                          |
| PV_FS_CHOWN   | Allows a process to change the ownership of a file                                              | chown, chownx, fchownx, lchown                                                                                                                                 |
| PV_FS_QUOTA   | Allows a process to manage disk quotas related operations                                       | quotactl                                                                                                                                                       |
| PV_FS_LINKDIR | Allows a process to make a hard link to a directory                                             | link, unlink, remove                                                                                                                                           |
| PV_FS_CNTL    | Allows a process to perform various control operations except extend and shrink on a filesystem | fscntl                                                                                                                                                         |
| PV_FS_RESIZE  | Allows a process to perform extend and shrink type of operations on a filesystem                | fscntl                                                                                                                                                         |
| PV_FS_CHROOT  | Allows a process to change its root directory                                                   | chroot                                                                                                                                                         |
| PV_FS_PDMODE  | Allows a process to make or set partitioned type directory                                      | pdmkdir                                                                                                                                                        |
| PV_FS_        | Equivalent to all above filesystem privileges (PV_FS_*) combined                                |                                                                                                                                                                |
| PV_PROC_PRIV  | Allows a process to modify or view privilege sets associated with a process                     | setppriv, getppriv                                                                                                                                             |
| PV_PROC_PRIO  | Allows a process/thread to change priority, policy and other scheduling parameters              | _prio_requeue, _setpri, _setpriority, _getpri, _sched_setparam, _sched_setscheduler, _thread_setsched, thread_boostceiling, thread_setmystate, thread_setstate |
| PV_PROC_CORE  | Allows a process to dump core                                                                   | gencore                                                                                                                                                        |
| PV_PROC_RAC   | Allows a process create more processes than the per-user limit                                  | appsetrlimit, setrlimit64, mlock, mlockall, munlock, munlockall, plock, upfget, upfput, restart, brk, sbrk                                                     |
| PV_PROC_RSET  | Allow to attach resource set (rset) to a process or thread                                      | bindprocessor, ra_attachrset, ra_detachrset, rs_registername, rs_setnameattr, rs_discardname, rs_setpartition, rs_getassociativity, kra_mmapv                  |
| PV_PROC_ENV   | Allows a process to set user information in the user structure                                  | ue_proc_register, ue_proc_unregister, usrinfo                                                                                                                  |
| PV_PROC_CKPT  | Allows a process to checkpoint or restart another process                                       | setcrid, restart                                                                                                                                               |
| PV_PROC_CRED  | Allows a process to set credential attributes                                                   | __pag_setvalue, __pag_setvalue64, __pag_genpagvalue                                                                                                            |
| PV_PROC_SIG   | Allows a process to send signal to an unrelated process                                         | _sigqueue, kill, signohup, gencore, thread_post, thread_post_many                                                                                              |

| Privilege      | Description                                                                                                                                        | System call reference                                                                                      |
|----------------|----------------------------------------------------------------------------------------------------------------------------------------------------|------------------------------------------------------------------------------------------------------------|
| PV_PROC_TIMER  | Allows a process to submit and use fine-granularity timers                                                                                         | appresabs, appresinc, absinterval, incinterval, _poll, _select<br>_timer_settime                           |
| PV_PROC_RTCLK  | Allows a process to access the CPU-time clock                                                                                                      | _clock_getres, _clock_gettime, _clock_settime, _clock_getcpuclid                                           |
| PV_PROC_VARS   | Allows a process to retrieve and update process tunable parameters                                                                                 | smttune                                                                                                    |
| PV_PROC_PDMODE | Allows a process to change REAL mode of partitioned directory                                                                                      | setppdmode                                                                                                 |
| PV_PROC_       | Equivalent to all above process privileges (PV_PROC_*) combined                                                                                    |                                                                                                            |
| PV_TCB         | Allows a process to modify the kernel trusted library path                                                                                         | chpriv, fchpriv                                                                                            |
| PV_TP          | Indicates a process is a trusted path process and allows actions limited to trusted path processes. (note: same as old AIX BYPASS_TPATH privilege) |                                                                                                            |
| PV_WPAR_CKPT   | Allows a process to perform checkpoint/restart operation in WPAR                                                                                   | smcr_proc_info, smcr_exec_info, smcr_mapinfo, smcr_net_oper, smcr_proccattr, aio_suspend_io, aio_resume_io |
| PV_KER_ACCT    | Allows a process to perform restricted operations pertaining to the accounting subsystem                                                           | acct, _acctctl, projctl                                                                                    |
| PV_KER_DR      | Allows a process to invoke dynamic reconfiguration operations                                                                                      | _dr_register, _dr_notify, _dr_unregister, dr_reconfig                                                      |
| PV_KER_TIME    | Allows a process to modify the system clock and system time                                                                                        | adjtime, appsettimer, _clock_settime                                                                       |
| PV_KER_RAC     | Allows a process to use large (non-pageable) pages for the shared memory segments                                                                  | shmctl, vmgetinfo                                                                                          |
| PV_KER_WLM     | Allows a process to initialize and modify WLM configuration                                                                                        | _wlm_set, _wlm_tune, _wlm_assign                                                                           |
| PV_KER_EWLM    | Allows a process to initialize or query the eWLM environment                                                                                       |                                                                                                            |
| PV_KER_VARS    | Allows a process to examine or set kernel runtime tunable parameters                                                                               | sys_parm, getkerninfo, __pag_setname, sysconfig, kunload64                                                 |
| PV_KER_REBOOT  | Allows a process to shut down the system                                                                                                           | reboot                                                                                                     |
| PV_KER_RAS     | Allows a process to configure or write RAS records, error logging, tracing, dumps functions                                                        | mtrace_set, mtrace_ctl                                                                                     |
| PV_KER_LVM     | Allows a process to configure the LVM subsystem                                                                                                    |                                                                                                            |
| PV_KER_NFS     | Allows a process to configure the NFS subsystem                                                                                                    |                                                                                                            |
| PV_KER_VMM     | Allows a process to modify swap parameters and other VMM tunable parameters in the kernel                                                          | swapoff, _swapon_ext, vmgetinfo                                                                            |

| Privilege        | Description                                                                                                  | System call reference                                                                                                       |
|------------------|--------------------------------------------------------------------------------------------------------------|-----------------------------------------------------------------------------------------------------------------------------|
| PV_KER_WPAR      | Allows a process to configure a workload partition                                                           | brand, corral_config, corral_delete, corral_modify, wpar_mkdevexport, wpar_rmdevexport, wpar_lsdevexport                    |
| PV_KER_CONF      | Allows a process to perform various system-configuration operations                                          | sethostname, sethostid, unameu, setdomainname                                                                               |
| PV_KER_EXTCONF   | Allows a process to perform various configuration tasks in kernel extensions (for kernel extension services) |                                                                                                                             |
| PV_KER_IPC       | Allows a process to raise the value of IPC message queue buffer and allow shmget with ranges to attach       | msgctl, shm_open, shmget, ra_shmget, ra_shmgetv, shmctl                                                                     |
| PV_KER_IPC_R     | Allows a process to read a IPC message queue, semaphore set, or shared memory segment                        | msgctl, __msgrcv, _mq_open, semctl, shmat, shm_open, __semop, shmctl, __semimedop, sem_post, _sem_wait, __msgrcv, __msgxrcv |
| PV_KER_IPC_W     | Allows a process to write a IPC message queue, semaphore set, or shared memory segment                       | _mq_open, shmat, _sem_open, semctl, shm_open, shmctl, mq_unlink, sem_unlink, shm_unlink, msgctl, __msgsnd                   |
| PV_KER_IPC_O     | Allows a process to override DAC ownership on all IPC objects                                                | msgctl, semctl, shmctl, fchmod, fchown                                                                                      |
| PV_KER_SECCONFIG | Allows a process to set kernel security flags                                                                | sec_setseconf, sec_setrunmode, sec_setsyslab, sec_getsyslab                                                                 |
| PV_KER_PATCH     | Allows a process to patch kernel extensions                                                                  |                                                                                                                             |
| PV_KER_          | Equivalent to all above kernel privileges (PV_KER_*) combined                                                |                                                                                                                             |
| PV_DEV_CONFIG    | Allows a process to configure kernel extensions and devices in the system                                    | sysconfig                                                                                                                   |
| PV_DEV_LOAD      | Allows a process to load and unload kernel extensions and devices in the system                              | sysconfig                                                                                                                   |
| PV_DEV_QUERY     | Allows a process to query kernel modules                                                                     | sysconfig                                                                                                                   |
| PV_SU_ROOT       | Grants the process all privileges associated with the standard AIX superuser                                 |                                                                                                                             |
| PV_SU_EMUL       | Grants the process all privileges associated with the standard AIX super user if the UID is 0                |                                                                                                                             |
| PV_SU_UID        | Causes the getuid system call to return 0                                                                    | getuidx                                                                                                                     |
| PV_SU_           | Equivalent to all of the above superuser privileges (PV_SU_*) combined                                       |                                                                                                                             |
| PV_NET_CNTL      | Allows a process to modify network tables                                                                    | socket, bind, listen, _naccept, econnect, ioctl, rmssock, setsockopt                                                        |
| PV_NET_PORT      | Allows a process to bind to privileged ports                                                                 | bind                                                                                                                        |



| Privilege      | Description                                                       | System call reference                      |
|----------------|-------------------------------------------------------------------|--------------------------------------------|
| PV_NET_RAWSOCK | Allows a process to have direct access to the network layer       | socket, _send, _sendto, sendmsg, _nsendmsg |
| PV_NET_CONFIG  | Allows a process to configure networking parameters               |                                            |
| PV_NET_        | Equivalent to all above networking privileges (PV_NET_*) combined |                                            |

The privileges listed in the following table are specific to Trusted AIX:

| Trusted AIX privilege | Description                                                                                                                                                                  | System call reference |
|-----------------------|------------------------------------------------------------------------------------------------------------------------------------------------------------------------------|-----------------------|
| PV_LAB_CL             | Allows a process to modify subject SCLs, subject to the process's clearance                                                                                                  |                       |
| PV_LAB_CLTL           | Allows a process to modify subject TCLs, subject to the process's clearance                                                                                                  |                       |
| PV_LAB_LEF            | Allows a process to read the label encoding file                                                                                                                             |                       |
| PV_LAB_SLDG           | Allows a process to downgrade SLs, subject to the process's clearance                                                                                                        |                       |
| PV_LAB_SLDG_STR       | Allows a process to downgrade the SL of a packet, subject to the process's clearance                                                                                         |                       |
| PV_LAB_SL_FILE        | Allows a process to change object SLs, subject to the process's clearance                                                                                                    |                       |
| PV_LAB_SL_PROC        | Allows a process to change subject SL, subject to the process's clearance                                                                                                    |                       |
| PV_LAB_SL_SELF        | Allows a process to change its own SL, subject to the process's clearance                                                                                                    |                       |
| PV_LAB_SLUG           | Allows a process to upgrade SLs, subject to the process's clearance                                                                                                          |                       |
| PV_LAB_SLUG_STR       | Allows a process to upgrade the SL of a packet, subject to the process's clearance                                                                                           |                       |
| PV_LAB_TL             | Allows a process to modify subject and object TLs                                                                                                                            |                       |
| PV_LAB_               | Equivalent to all above label privileges (PV_LAB_*) combined                                                                                                                 |                       |
| PV_MAC_CL             | Allows a process to bypass sensitivity clearance restrictions                                                                                                                |                       |
| PV_MAC_R_PROC         | Allows a process to bypass MAC read restrictions when getting information about a process, provided that the target process's label is within the acting process's clearance |                       |

| Trusted AIX privilege | Description                                                                                                                                                             | System call reference |
|-----------------------|-------------------------------------------------------------------------------------------------------------------------------------------------------------------------|-----------------------|
| PV_MAC_W_PROC         | Allows a process to bypass MAC write restrictions when sending a signal to a process, provided that the target process's label is within the acting process's clearance |                       |
| PV_MAC_R              | Allows a process to bypass MAC read restrictions                                                                                                                        |                       |
| PV_MAC_R_CL           | Allows a process to bypass MAC read restrictions when the object's label is within the process's clearance                                                              |                       |
| PV_MAC_R_STR          | Allows a process to bypass MAC read restrictions when reading a message from a STREAM, provided that the message's label is within the process's clearance              |                       |
| PV_MAC_W              | Allows a process to bypass MAC write restrictions                                                                                                                       |                       |
| PV_MAC_W_CL           | Allows a process to bypass MAC write restrictions when the object's label is within the process's clearance                                                             |                       |
| PV_MAC_W_DN           | Allows a process to bypass MAC write restrictions when the process label dominates the object's label and the object's label is within the process's clearance          |                       |
| PV_MAC_W_UP           | Allows a process to bypass MAC write restrictions when the process label is dominated by the object's label and the object's label is within the process's clearance    |                       |
| PV_MAC_OVRRD          | Bypasses MAC restrictions for files flagged as being exempt from MAC                                                                                                    |                       |
| PV_MAC_               | Equivalent to all above MAC privileges (PV_MAC_*) combined                                                                                                              |                       |
| PV_MIC                | Allows a process to bypass integrity restrictions                                                                                                                       |                       |
| PV_MIC_CL             | Allows a process to bypass integrity clearance restrictions                                                                                                             |                       |

## Access Control Lists

Typically an ACL consists of series of entries called an Access Control Entry (ACE). Each ACE defines the access rights for a user in relationship to the object.

When an access is attempted, the operating system will use the ACL associated with the object to see whether the user has the rights to do so. These ACLs and the related access checks form the core of the Discretionary Access Control (DAC) mechanism supported by AIX.

The operating system supports several types of system objects that allow user processes to store or communicate information. The most important types of access controlled objects are as follows:

- Files and directories
- Named pipes

- IPC objects such as message queues, shared memory segments, and semaphores

All access permission checks for these objects are made at the system call level when the object is first accessed. Because System V Interprocess Communication (SVIPC) objects are accessed statelessly, checks are made for every access. For objects with file system names, it is necessary to be able to resolve the name of the actual object. Names are resolved either relatively (to the process' working directory) or absolutely (to the process' root directory). All name resolution begins by searching one of these directories.

The discretionary access control mechanism allows for effective access control of information resources and provides for separate protection of the confidentiality and integrity of the information. Owner-controlled access control mechanisms are only as effective as users make them. All users must understand how access permissions are granted and denied, and how these are set.

For example, an ACL associated with a file system object (file or directory) could enforce the access rights for various users in regards to access of the object. It is possible that such an ACL could enforce different levels of access rights, such as read or write, for different users.

Typically, each object will have a defined owner and, in some cases, be associated to a primary group . The owner of a specific object controls its discretionary access attributes. The owner's attributes are set to the creating process's effective user ID.

The following table lists direct access control attributes for the different types of objects:

#### **Owner**

For System V Interprocess Communication (SVIPC) objects, the creator or owner can change the object's ownership. SVIPC objects have an associated creator that has all the rights of the owner (including access authorization). The creator cannot be changed, even with root authority.

SVIPC objects are initialized to the effective group ID of the creating process. For file system objects, the direct access control attributes are initialized to either the effective group ID of the creating process or the group ID of the parent directory (this is determined by the group inheritance flag of the parent directory).

**Group** The owner of an object can change the group. The new group must be either, the effective group ID of the creating process, or the group ID of the parent directory. (As above, SVIPC objects have an associated creating group that cannot be changed, and share the access authorization of the object group.)

**Mode** The **chmod** command (in numeric mode with octal notations) can set base permissions and attributes. The **chmod** subroutine that is called by the command, disables extended permissions. The extended permissions are disabled if you use the numeric mode of the **chmod** command on a file that has an ACL. The symbolic mode of the **chmod** command disables extended ACLs for NSF4 ACL type but does not disable extended permissions for AIXC type ACLs. For information about numeric and symbolic mode, see **chmod**.

Many objects in the operating system, such as sockets and file system objects, have ACLs associated for different subjects. Details of ACLs for these object types could vary from one to another.

Traditionally, AIX has supported mode bits for controlling access to the file system objects. It has also supported a unique form of ACL around mode bits. This ACL consisted of base mode bits and also allowed for the definition of multiple ACE entries; each ACE entry defining access rights for a user or group around the mode bits. This classic type of ACL behavior existed prior to AIX 5.3 and will continue to be supported. This ACL type has been named as AIXC ACL type.

Note that support of an ACL on file system objects depends on the underlying physical file system (PFS). The PFS must understand the ACL data and be able to store, retrieve, and enforce the accesses for various users. It is possible that some of the physical file systems do not support any ACLs at all (may just

support the base mode bits) as compared to a physical file system that supported multiple types of ACLs. Beginning with AIX 5.3, few of the file systems under AIX have been enhanced to support multiple ACL types. JFS2 and GPFS™ will have the capability to support NFS version 4 protocol based ACL type too. This ACL has been named NFS4 ACL type on AIX. This ACL type adheres to most of the ACL definition in the NFS version 4 protocol specifications. It also supports more granular access controls as compared to the AIXC ACL type and provides for capabilities such as inheritance.

## Multiple Access Control List type framework support

Beginning with version 5.3.0, AIX supports an infrastructure for different Access Control List (ACL) types to exist for different file system objects within the operating system.

This infrastructure allows for uniform methods to manage ACLs irrespective of the ACL type associated with the object. The framework includes the following components:

### ACL administration commands

These are commands, such as **aclget**, **aclput**, **acledit**, **aclconvert**, **aclgettypes**. These commands call library interfaces that invoke ACL-type-specific modules.

### ACL library interfaces

ACL Library interfaces act as front-ends to the applications that need to access ACLs.

### ACL-type-specific dynamically loadable ACL modules

AIX provides a set of ACL-type-specific modules for AIX Classic ACLs (**AIXC**) and NFS4 ACLs (**nfs4**).

### *Binary compatibility:*

There are no compatibility issues for applications that run on the existing JFS2 file systems, with or without the existing AIX ACLs.

However, note that applications might find that access to files might fail if they encounter file system objects with much stricter ACLs (such as NFS4) associated. Simple checks to see whether the file exists will require level of read permission in NFS4 ACL.

## Access Control List types supported on AIX

AIX currently supports AIXC and NFS4 ACL types.

As mentioned, it also supports an infrastructure for the addition of any other ACL type supported by the underlying physical file system. Note that the JFS2 PFS supports NFS4 ACL natively if the file system instance is created with Extended Attributes Version 2 capability.

### *AIXC Access Control List:*

The AIXC Access Control List type represents the behavior of the ACL type supported on AIX releases prior to 5.3.0. AIXC ACLs include base permissions and extended permissions.

The AIXC Access Control List (ACL) type represents the behavior of the ACL type supported on AIX releases prior to 5.3.0. AIXC ACLs include base permissions and extended permissions. The JFS2 file system allows a maximum size of 4 KB for AIXC ACLs.

### Setting base permissions for AIXC ACL

Base permissions are the traditional file-access modes assigned to the file owner, file group, and other users. The access modes are: read (r), write (w), and execute/search (x).

In an ACL, base permissions are in the following format, with the *Mode* parameter expressed as rwx (with a hyphen (-) replacing each unspecified permission):

```
base permissions:
 owner(name): Mode
 group(group): Mode
 others: Mode
```

## Setting attributes for AIXC ACL

The following attributes can be added to an AIXC ACL:

### setuid (SUID)

Set-user-ID mode bit. This attribute sets the effective and saved user IDs of the process to the owner ID of the file at run time.

### setgid (SGID)

Set-group-ID mode bit. This attribute sets the effective and saved group IDs of the process to the group ID of the file at run time.

### savetext (SVTX)

For directories, indicates that only file owners can link or unlink files in the specified directory.

These attributes are added in the following format:

```
attributes: SUID, SGID, SVTX
```

## Setting extended permissions for AIXC Access ACL

Extended permissions allow the owner of a file to more precisely define access to that file. Extended permissions modify the base file permissions (owner, group, others) by permitting, denying, or specifying access modes for specific individuals, groups, or user and group combinations. Permissions are modified through the use of keywords.

The **permit**, **deny**, and **specify** keywords are defined as follows:

|                |                                                                         |
|----------------|-------------------------------------------------------------------------|
| <b>permit</b>  | Grants the user or group the specified access to the file               |
| <b>deny</b>    | Restricts the user or group from using the specified access to the file |
| <b>specify</b> | Precisely defines the file access for the user or group                 |

If a user is denied a particular access by either a **deny** or a **specify** keyword, no other entry can override that access denial.

The **enabled** keyword must be specified in the ACL for the extended permissions to take effect. The default value is the **disabled** keyword.

In an ACL, extended permissions are in the following format:

```
extended permissions:
 enabled | disabled
 permit Mode UserInfo...
 deny Mode UserInfo...
 specify Mode UserInfo...
```

Use a separate line for each **permit**, **deny**, or **specify** entry. The *Mode* parameter is expressed as **rwX** (with a hyphen (-) replacing each unspecified permission). The *UserInfo* parameter is expressed as **u:UserName**, or **g:GroupName**, or a comma-separated combination of **u:UserName** and **g:GroupName**.

**Note:** Because a process has only one user ID, if more than one user name is specified in an entry, that entry cannot be used in an access control decision.

## Textual representation of AIXC ACL

The following stanza shows the textual representation of an AIXC ACL:

```
Attributes: { SUID | SGID | SVTX }
Base Permissions:
 owner(name): Mode
 group(group): Mode
 others: Mode
Extended Permissions:
 enabled | disabled
 permit Mode UserInfo...
 deny Mode UserInfo...
 specify Mode UserInfo...
```

## Binary format of AIXC ACL

The AIXC ACL binary format is defined in `/usr/include/sys/acl.h` and is implemented in the current AIX release.

## AIXC ACL example

The following is an example of an AIXC ACL:

```
attributes: SUID
base permissions:
 owner(frank): rw-
 group(system): r-x
 others: ---
extended permissions:
 enabled
 permit rw- u:dhs
 deny r-- u:chas, g:system
 specify r-- u:john, g:gateway, g:mail
 permit rw- g:account, g:finance
```

The ACL entries are described as follows:

- The first line indicates that the **setuid** bit is turned on.
- The next line, which introduces the base permissions, is optional.
- The next three lines specify the base permissions. The owner and group names in parentheses are for information only. Changing these names does not alter the file owner or file group. Only the **chown** command and the **chgrp** command can change these file attributes.
- The next line, which introduces the extended permissions, is optional.
- The next line indicates that the extended permissions that follow are enabled.
- The last four lines are the extended entries. The first extended entry grants user *dhs* read (r) and write (w) permission on the file.
- The second extended entry denies read (r) access to user *chas* only when he is a member of the *system* group.
- The third extended entry specifies that as long as user *john* is a member of both the *gateway* group and the *mail* group, he has read (r) access. If user *john* is not a member of both groups, this extended permission does not apply.
- The last extended entry grants any user in *both* the *account* group and the *finance* group read (r) and write (w) permission.

**Note:** More than one extended entry can apply to a process that is requesting access to a controlled object, with restrictive entries taking precedence over permissive modes.

For the complete syntax, see the **acledit** command in the *AIX Version 6.1 Commands Reference*.

## NFS4 Access Control List:

AIX also supports the NFS4 Access Control List (ACL) type.

The NFS4 ACL type implements access control as specified in the *Network File System (NFS) version 4 Protocol RFC 3530*. The JFS2 file system allows a maximum size of 64KB for NFS4 ACLs.

### Textual representation of NFS4 ACL

A textual NFS V4 ACL is a list of ACEs (Access Control Entries) each ACE per line. An ACE has four elements in the following format.

```
IDENTITY ACE_TYPE ACE_MASK ACE_FLAGS
```

where:

```
IDENTITY => Has format of 'IDENTITY_type:(IDENTITY_name or IDENTITY_ID or IDENTITY_who):'
```

```
 where:
```

```
 IDENTITY_type => One of the following Identity type:
```

```
 u : user
```

```
 g : group
```

```
 s : special who string (IDENTITY_who must be a special who)
```

```
 IDENTITY_name => user/group name
```

```
 IDENTITY_ID => user/group ID
```

```
 IDENTITY_who => special who string (e.g. OWNER@, GROUP@, EVERYONE@)
```

```
ACE_TYPE => One of the following ACE Type:
```

```
 a : allow
```

```
 d : deny
```

```
 l : alarm
```

```
 u : audit
```

```
ACE MASK => One or more of the following Mask value Key without separator:
```

```
 r : READ_DATA or LIST_DIRECTORY
```

```
 w : WRITE_DATA or ADD_FILE
```

```
 p : APPEND_DATA or ADD_SUBDIRECTORY
```

```
 R : READ_NAMED_ATTRS
```

```
 W : WRITE_NAMED_ATTRS
```

```
 x : EXECUTE or SEARCH_DIRECTORY
```

```
 D : DELETE_CHILD
```

```
 a : READ_ATTRIBUTES
```

```
 A : WRITE_ATTRIBUTES
```

```
 d : DELETE
```

```
 c : READ_ACL
```

```
 C : WRITE_ACL
```

```
 o : WRITE_OWNER
```

```
 s : SYNCHRONIZE
```

```
ACE_FLAGS (Optional) => One or more of the following Attribute Key without separator:
```

```
 fi : FILE_INHERIT
```

```
 di : DIRECTORY_INHERIT
```

```
 oi : INHERIT_ONLY
```

```
 ni : NO_PROPAGATE_INHERIT
```

```
 sf : SUCCESSFUL_ACCESS_ACE_FLAG
```

```
 ff : FAILED_ACCESS_ACE_FLAG
```

**Note:** Concerning the SYNCHRONIZE Ace\_Mask value key, s, AIX does not take any action concerning this value key. AIX stores and preserves the s value key but this value key does not have any meaning to AIX.

When the WRITE\_OWNER Ace\_Mask is set to Ace\_Type allow, users can change ownership of the file to themselves only.

Deleting a file depends on two ACEs, the DELETE entry of the object to be deleted and the DELETE\_CHILD entry of its parent directory. AIX provides the user with two modes of behavior. In the *secure* mode, DELETE behaves similar to AIXC ACLs. In the *compatibility* mode, DELETE behaves like other major implementations of NFS4 ACLs. To turn on the compatibility mode, use the **chdev** command as follows:

```
chdev -l sys0 -a nfs4_acl_compat='true'
```

You must reboot the system after running the **chdev** command before the configuration change will take place.

If you switch your system back and forth between the two modes, you need to be aware that NFS4 ACLs generated by AIX in secure mode might not be accepted by other platforms even if the system was changed back to compatibility mode.

Example:

```
u:user1(aa@ibm.com): a rwp fidi
*s:(OWNER@): d x dini * This line is a comment
g:staff(jj@jj.com): a rx
s:(GROUP@): a rwpx fioi
u:2: d r di * This line shows user bin (uid=2)
g:7: a ac fi * This line shows group security (gid=7)
s:(EVERYONE@): a rca ni
```

## Binary format for NFS4 ACL

The NFS4 ACL binary format is defined in **/usr/include/sys/acl.h** and is implemented in the current AIX release.

## NFS4 ACL example

The following example shows an NFS4 ACL applied on a directory (such as, **/j2eav2/d0**):

```
s:(OWNER@): a rwpRWxDdo difi * 1st ACE
s:(OWNER@): d D difi * 2nd ACE
s:(GROUP@): d x ni * 3rd ACE
s:(GROUP@): a rx difi * 4th ACE
s:(EVERYONE@): a c difi * 5th ACE
s:(EVERYONE@): d C difi * 6th ACE
u:user1: a wp oi * 7th ACE
g:grp1: d wp * 8th ACE
u:101: a C * 9th ACE
g:100: d c * 10th ACE
```

The ACL entries are described as follows:

- The first ACE indicates that the owner has the following privileges on **/j2eav2/d0** and all its offspring created after this ACL is applied:
  - READ\_DATA (= LIST\_DIRECTORY)
  - WRITE\_DATA (=ADD\_FILE)
  - APPEND\_DATA (= ADD\_SUBDIRECTORY)
  - READ\_NAMED\_ATTR
  - WRITE\_NAMED\_ATTR
  - EXECUTE (=SEARCH\_DIRECTORY)
  - DELETE\_CHILD
  - DELETE
  - WRITE\_OWNER
- The second ACE indicates the owner is denied the privilege for DELETE\_CHILD (deleting the files or subdirectories created under **/j2eav2**), but owner can still delete them because of the first ACE, which allows owner the privilege for DELETE\_CHILD.
- The third ACE indicates all members of the group for the object (**/j2eav2/d0**) are denied the privilege for EXECUTE (=SEARCH\_DIRECTORY), but the owner is still allowed that privilege by the first ACE. This ACE can not be propagated to all of its offsprings because the NO\_PROPAGATE\_INHERIT flag is specified. This ACE is applied only to the directory **/j2eav2/d0** and its immediate child files and subdirectories.
- The fourth ACE indicates that every member of the group of the object (**/j2eav2/d0**) is allowed the privilege for READ\_DATA (= LIST\_DIRECTORY) and EXECUTE (=SEARCH\_DIRECTORY) on **/j2eav2/d0** and all its



offsprings. However, because of third ACE group members (except the owner) are not allowed the privilege for EXECUTE (=SEARCH\_DIRECTORY) on the **/j2eav2/d0** directory and its immediate child files and subdirectories.

- The fifth ACE indicates that everyone is allowed the privilege for READ\_ACL on the **/j2eav2/d0** directory and any offspring that are created after this ACL is applied.
- The sixth ACE indicates that everyone is denied the privilege for WRITE\_ACL on the **/j2eav2/d0** directory and any offspring. The owner always has the privilege for WRITE\_ACL on files and directories with NFS4 ACLs.
- The seventh ACE indicates that user1 has the privilege for WRITE\_DATA (=ADD\_FILE) and APPEND\_DATA (= ADD\_SUBDIRECTORY) on all the offspring of the **/j2eav2/d0** directory but not on the **/j2eav2/d0** directory itself.
- The eighth ACE indicates that all the members of grp1 are denied the privilege for WRITE\_DATA (=ADD\_FILE) and APPEND\_DATA (= ADD\_SUBDIRECTORY). This ACE does not apply to the owner even it belongs to grp1 because of the first ACE.
- The ninth ACE indicates that the user with **UID 101** has the privilege for WRITE\_ACL, but no one, except the owner has the privilege for WRITE\_ACL because of the sixth ACE.
- The tenth ACE indicates that all the members of the group with **GID 100** are denied for READ\_ACL, but they will have this privilege because of the fifth ACE.

## Access Control List Management

There are several methods of managing ACLs. AIX users can use the Web-based System Manager to view and set ACLs, or they can use the commands.

Applications programmers and other subsystem developers can use the ACL library interfaces and ACL conversion routines described in this section.

### ACL administration commands

You can use the following commands to work with ACLs for a file system object:

**aclget** Writes to standard output the ACL of the file object named *FileObject*, presented in readable format or writes the same to the output file named *outAclFile*.

**aclput** Sets the ACL of *FileObject* on the file system using the input specified through standard input or *inAclFile*.

#### **acledit**

Opens an editor for editing the ACL of the specified *FileObject*.

#### **aclconvert**

Converts an ACL from one type to another type. This command fails if the conversion is not supported.

#### **aclgettypes**

Gets ACL types supported by a file system path.

### ACL library interfaces

ACL Library interfaces act as front-ends to the applications that need to access ACLs. The applications (including the generic ACL administration commands given above) do not directly invoke the undocumented ACL syscalls; instead, they access the generic syscalls and the type-specific loadable modules via the library interfaces. This will shield the customer application programmers from the complexity of using loadable modules, and reduces the backward binary compatibility issues for future AIX releases.

The following library interfaces call syscalls.

### **aclx\_fget and aclx\_get**

The **aclx\_get** and **aclx\_fget** functions retrieve the access control information for a file system object, and put it into the memory region specified by **acl**. The size and type information for the **acl** are stored in **\*acl\_sz** and **\*acl\_type**.

### **aclx\_fput and aclx\_put**

The **aclx\_put** and **aclx\_fput** functions store the access control information specified in **acl** for the input file object. These functions do not do ACL type conversions; for doing ACL type conversion, the caller has to explicitly call the **aclx\_convert** function.

### **aclx\_gettypes**

The **aclx\_gettypes** function gets the list of ACL types supported on the particular file system. A file system type can support more than one ACL type simultaneously. Each file system object is associated with a unique ACL type belonging to the list of ACL types supported by the file system.

### **aclx\_gettypeinfo**

The **aclx\_gettypeinfo** function gets the characteristics and capabilities of an ACL type on the file system specified by path. Note that the ACL characteristics will normally be of a data structure type, which is specific for each particular ACL type. The data structures used for AIXC and NFS4 ACLs will be described in a separate document.

### **aclx\_print and aclx\_printStr**

These two functions convert the ACL given in binary format into textual representation. These functions are called by the **aclget** and **acledit** commands.

### **aclx\_scan and aclx\_scanStr**

These two functions convert the given textual representation of the ACL into binary format.

### **aclx\_convert**

Converts an ACL from one type to another. This function is used for implicit conversion by commands, such as **cp**, **mv**, or **tar**.

## **ACL conversion**

ACL conversion allows you to convert one ACL type to another. Support of multiple ACL types is dependent upon what ACL types are supported on a specific physical file system. All file systems do not support all ACL types. For example, file system one might support only AIXC ACL types, and file system two might support AIXC and NFS4 ACL types. You can copy AIXC ACLs between the two file systems, but you must use ACL conversion to copy the NFS ACLs from file system two to file system one. ACL conversion preserves the access control information as much as possible.

**Note:** The conversion process is approximate and could result in loss of access control information. You should consider this when planning your ACL conversions.

ACL conversion in AIX is supported with the following infrastructure:

### **Library routines**

These routines and user level ACL framework enable ACL conversion from one ACL type to another.

### **aclconvert command**

This command converts ACLs.

### **aclput and acledit commands**

These commands are used to modify ACL types.

### **cp and mv commands**

These commands have been enabled to handle multiple ACL types and perform any internal ACL conversion, as necessary.

## backup command

This command converts the ACL information to a known type and form (AIXC ACL type), if requested to backup in the legacy format. To retrieve the ACL in its native format, specify the **-U** option. See `backup` for more information.

Each ACL type is unique, and refinement of access control masks varies widely from one ACL type to another. The conversion algorithms are approximate and are not equivalent to manually converting an ACL. In some cases, the conversion will not be exact. For example, NFS4 ACLs cannot truly be converted to AIXC ACLs because NFS4 ACLs provides up to 16 access masks and has inheritance features that are not supported in the AIXC ACL type). You should not use the ACL conversion facilities and interfaces if you are concerned about the loss of access control information.

**Note:** The ACL conversion algorithms are proprietary in nature and are subject to change.

## S bits and Access Control Lists

You can use `setuid` and `setgid` programs and applying S bits to ACLs.

### Using `setuid` and `setgid` programs

The permission bits mechanism allows effective access control for resources in most situations. But for more precise access control, the operating system provides the `setuid` and `setgid` programs.

AIX defines identity only in terms of uids and gids. ACL types that do not define identity with uids and gids are mapped to the AIX identity model. For example, the NFS4 ACL type defines user identity as strings of the form `user@domain`, and this string is mapped to numeric UIDs and GIDs.

Most programs run with the user and group access rights of the user who invoked them. Program owners can associate the access rights of the user who invoked them by making the program a `setuid` or `setgid` program; that is, a program with the `setuid` or `setgid` bit set in its permissions field. When that program is run by a process, the process acquires the access rights of the owner of the program. A `setuid` program runs with the access rights of its owner, while a `setgid` program has the access rights of its group, and both bits can be set according to the permission mechanism.

Although the process is assigned the additional access rights, these rights are controlled by the program bearing the rights. Thus, the `setuid` and `setgid` programs allow for user-programmed access controls in which access rights are granted indirectly. The program acts as a trusted subsystem, guarding the user's access rights.

Although these programs can be used with great effectiveness, there is a security risk if they are not designed carefully. In particular, the program must never return control to the user while it still has the access rights of its owner, because this would allow a user to make unrestricted use of the owner's rights.

**Note:** For security reasons, the operating system does not support `setuid` or `setgid` program calls within a shell script.

### Applying S bits to ACLs

ACLs such as NFS4 do not directly deal with the S bits. NFS4 ACL does not specify how these bits could be accommodated as part of the ACL. AIX has approached the problem such that S bits will be used while performing access checks and will compliment any NFS4 ACL related access checks. AIX's `chmod` command can be used set or reset S bits on file system objects with ACLs such as NFS4.

## Administrative access rights

The operating system provides privileged access rights for system administration.

System privilege is based on user and group IDs. Users with effective user or group IDs of 0 are recognized as privileged.

Processes with effective user IDs of 0 are known as root-user processes and can:

- Read or write any object
- Call any system function
- Perform certain subsystem control operations by executing **setuid-root** programs.

You can manage the system using two types of privilege: the **su** command privilege and **setuid-root** program privilege. The **su** command allows all programs you invoke to function as root-user processes. The **su** command is a flexible way to manage the system, but it is not very secure.

Making a program into a **setuid-root** program means the program is a root-user-owned program with the setuid bit set. A **setuid-root** program provides administrative functions that ordinary users can perform without compromising security; the privilege is encapsulated in the program rather than granted directly to the user. It can be difficult to encapsulate all necessary administrative functions in **setuid-root** programs, but it provides more security to system managers.

## Access authorization

When a user logs in to an account (using the **login** or **su** commands), the user IDs and group IDs assigned to that account are associated with the user's processes. These IDs determine the access rights of the process.

A process with a user ID of 0 is known as a *root user process*. These processes are generally allowed all access permissions. But if a root user process requests execute permission for a program, access is granted only if execute permission is granted to at least one user.

## Access Authorization for AIXC ACLs

The owner of the information resource is responsible for managing access rights. Resources are protected by *permission bits*, which are included in the mode of the object. The permission bits define the access permissions granted to the owner of the object, the group of the object, and for the others default class. The operating system supports three different modes of access (read, write, and execute) that can be granted separately.

For files, directories, named pipes, and devices (special files), access is authorized as follows:

- For each access control entry (ACE) in the ACL, the identifier list is compared to the identifiers of the process. If there is a match, the process receives the permissions and restrictions defined for that entry. The logical unions for both permissions and restrictions are computed for each matching entry in the ACL. If the requesting process does not match any of the entries in the ACL, it receives the permissions and restrictions of the default entry.
- If the requested access mode is permitted (included in the union of the permissions) and is not restricted (included in the union of the restrictions), access is granted. Otherwise, access is denied.

The identifier list of an ACL matches a process if all identifiers in the list match the corresponding type of effective identifier for the requesting process. A USER-type identifier matches if it is equal to the effective user ID of the process, and a GROUP-type identifier matches if it is equal to the effective group ID of the process or to one of the supplementary group IDs. For instance, an ACE with an identifier list such as the following:

```
USER:fred, GROUP:philosophers, GROUP:software_programmer
```

would match a process with an effective user ID of *fred* and a group set of:

```
philosophers, philanthropists, software_programmer, doc_design
```

but would not match for a process with an effective user ID of *fred* and a group set of: *philosophers*, *iconoclasts*, *hardware\_developer*, *graphic\_design*

Note that an ACE with an identifier list of the following would match for both processes:

```
USER:fred, GROUP:philosophers
```

In other words, the identifier list in the ACE functions is a set of conditions that must hold for the specified access to be granted.

All access permission checks for these objects are made at the system call level when the object is first accessed. Because System V Interprocess Communication (SVIPC) objects are accessed statelessly, checks are made for every access. For objects with file system names, it is necessary to be able to resolve the name of the actual object. Names are resolved either relatively (to the process' working directory) or absolutely (to the process' root directory). All name resolution begins by searching one of these directories.

The discretionary access control mechanism allows for effective access control of information resources and provides for separate protection of the confidentiality and integrity of the information. Owner-controlled access control mechanisms are only as effective as users make them. All users must understand how access permissions are granted and denied, and how these are set.

## Access Authorization for NFS4 ACLs

Any user who has the privilege for `WRITE_ACL` can control the access rights. The owner of the information resource is always has the privilege for `WRITE_ACL`. For files and directories with NFS4 ACLs, access is authorized as follows:

- The list of ACEs is processed in order and only those ACEs which have a "who" (i.e. Identity ) that matches the requester are considered for processing. The credentials of the requester is not checked while processing the ACE with special who `EVERYONE@`.
- Each ACE is processed until all of the bits of requester's access have been allowed. Once a bit is has been allowed, it is no longer considered in the processing of later ACEs.
- If any bit corresponding to the requester's access is denied, access is denied and the remaining ACEs are not processed.
- If all of the bits of requester's access have not been allowed, and there is no ACE left for processing, access is denied.

If the access requested is denied by the ACEs and the requesting user is superuser or root, access is generally allowed. Note that the object owner is always permitted for `READ_ACL`, `WRITE_ACL`, `READ_ATTRIBUTES`, and `WRITE_ATTRIBUTES`. For more information on the algorithm for access authorization, see "NFS4 Access Control List" on page 111.

## Access Control List Troubleshooting

The following information can be used for troubleshooting the Access Control List (ACL).

### NFS4 Access Control List on an object failed application

You can use the return code or the trace facility to troubleshoot problems with setting an NFS4 ACL on an object, such as a file or directory. Both methods use command the `aclput` command and the `acledit` command to find the cause of the problem.

### Using the Return Code for troubleshooting

To display the return code, use the `echo $?` command after you run the `aclput` command. The following lists shows the return codes and their explanations:

## 22 (EINVAL, defined in /usr/include/sys/errno.h)

The following are possible causes for this code:

- Invalid textual format in any field of the 4 fields.
- The size of the input NFS4 ACL is more than 64 KB.
- The ACL is applied on a file that already has at least one ACE with ACE mask set to w (WRITE\_DATA) but not p (APPEND\_DATA) or p (APPEND\_DATA) but not w (WRITE\_DATA).
- The ACL is applied on a directory that already has at least one ACE with ACE mask set to w (WRITE\_DATA) but not p (APPEND\_DATA) or p (APPEND\_DATA) but not w (WRITE\_DATA), and the ACE flag fi (FILE\_INHERIT).
- There is at least one ACE with OWNER@ set as a special **who (Identity)** and one or more of the ACE masks c (READ\_ACL), C (WRITE\_ACL), a (READ\_ATTRIBUTE) and A (WRITE\_ATTRIBUTE) are being denied by ACE type d.

## 124 (ENOTSUP, defined in /usr/include/sys/errno.h)

The following are possible causes for this code:

- The special who might not be any one of the three values (OWNER@, GROUP@, or EVERYONE@) in one of the ACEs.
- There is at least one ACE with ACE type u (AUDIT) or l (ALARM).

## 13 (EACCES, defined in /usr/include/sys/errno.h)

The following are possible causes for this code:

- You are not allowed to read the input file containing NFS4 ACEs.
- You are not allowed to search the parent directory of the target object because you do not have x (EXECUTE) permission on the parent directory of the target object.
- You might not be allowed to write or change the ACL. If the object is already associated with an NFS4 ACL ensure that you have the privilege for the ACE mask C (WRITE\_ACL).

## Using the Trace facility for troubleshooting

You can also generate a trace report to find the cause of the problem. The following scenario shows how to use trace to find the cause of the problem applying an NFS4 ACL. If you have a file, **/j2v2/file1** with the following NFS4 ACL:

```
s:(EVERYONE@): a acC
```

And, the following ACL is contained in the **input\_acl\_file** input file:

```
s:(EVERYONE@): a rwxacC
```

Complete the following steps to troubleshoot with the trace facility:

1. Run the trace, **aclput** and **trcrpt** using the following commands:

```
$ trace -j 478 -o trc.raw
$->!aclput -i input_acl_file -t NFS4 /j2v2/file1
$ ->quit
$ trcrpt trc.raw > trc.rpt
```

2. Analyze the trace report. When the ACL is applied on a file or directory, it checks for the access to write or change the ACL, and then applies the ACL. The file contains lines similar to the following:

```
478 xxx xxx ACL ENGINE: chk_access entry: type=NFS4 obj_mode=33587200 size=68 ops=16384 uid=100

478 xxx xxx ACL ENGINE: chk_access exit: type=NFS4 rc=0 ops=16384 priv=0 against=0
478 xxx xxx ACL ENGINE: set_acl entry: type=NFS4 ctl_flg=2 obj_mode=33587200 mode=0 size=48

478 xxx xxx ACL ENGINE: validate_acl: type=NFS4 rc=22 ace_cnt=1 acl_len=48 size=12
478 xxx xxx ACL ENGINE: set_acl exit: type=NFS4 rc=22 obj_mode=33587200 size=68 cmd=536878912
```

The second line containing, **chk\_access exit**, indicates access is allowed (**rc = 0**) to write the ACL. The fourth line, containing **validate\_acl**, and the fifth line, containing **set\_acl exit**, indicate that the

ACL is not applied successfully (rc=22 indicates **EINVAL**). The fourth line, containing `validate_acl`, indicates there is problem in the first line of the ACE (`ace_cnt=1`). If you refer to the first ACE, `s:(EVERYONE@): a rwxacC`, there is no **p** as the access mask. The **p** is needed in addition to the **w** when applying the ACL.

## Troubleshooting access denies

A filesystem operation (for example, read or write) might fail on an object associated with an NFS4 ACL. Usually, an error message is displayed, but that message might not contain enough information to determine the access problem. You can use the trace facility to find the access problem. For example, if you have a file, `/j2v2/file2` with the following NFS4 ACL:

```
s:(EVERYONE@): a rwx
```

The following command reports a "Permission denied" error:

```
ls -l /j2v2/file2
```

Complete the following steps to troubleshoot this problem:

1. Run the trace, `ls -l /j2v2/file2` and `trcrpt` using the following commands:

```
$ trace -j 478 -o trc.raw
$->!ls -l /j2v2/file2
$ ->quit
$ trcrpt trc.raw > trc.rpt
```

2. Analyze the trace report. The file contains lines similar to the following:

```
478 xxx xxx ACL ENGINE: chk_access entry: type=NFS4 obj_mode=33587711 size=68 ops=1024 uid=100
478 xxx xxx ACL ENGINE: nfs4_chk_access_self: type=NFS4 aceN=1 aceCnt=1 req=128 deny=0
478 xxx xxx ACL ENGINE: nfs4_mask_privcheck: type=NFS4 deny=128 priv=128
478 xxx xxx ACL ENGINE: chk_access exit: type=NFS4 rc=13 ops=1024 priv=0 against=0
```

The third line indicates the access is denied for access mask = 128 (**0x80**) which is only `READ_ATTRIBUTES` (see the `/usr/include/sys/acl.h` file).

## Auditing overview

The auditing subsystem enables the system administrator to record security-relevant information, which can be analyzed to detect potential and actual violations of the system security policy.

### Auditing subsystem

The auditing subsystem has detection, collection, and processing functions.

- "Auditing event detection"
- "Event information collection" on page 120
- "Audit trail information processing" on page 120

The system administrator can configure each of these functions.

### Auditing event detection

Event detection is distributed throughout the Trusted Computing Base (TCB), both in the kernel (supervisor state code) and the trusted programs (user state code). An auditable event is any security-relevant occurrence in the system. A security-relevant occurrence is any change to the security state of the system, any attempted or actual violation of the system access control or accountability security policies, or both. The programs and kernel modules that detect auditable events are responsible for reporting these events to the system audit logger, that runs as part of the kernel and can be accessed either with a subroutine (for trusted program auditing) or within a kernel procedure call (for supervisor state auditing). The information reported includes the name of the auditable event, the success or failure of the event, and any additional event-specific information that is relevant to security auditing.

Event detection configuration consists of turning event detection on or off, and specifying which events are to be audited for which users. To activate event detection use the **audit** command to enable or disable the audit subsystem. The **/etc/security/audit/config** file contains the events and users that are processed by the audit subsystem.

## Event information collection

Information collection encompasses logging the selected auditable events. This function is performed by the kernel audit logger, which provides both a system call and an intra-kernel procedure call interface that records auditable events.

The audit logger is responsible for constructing the complete audit record, consisting of the audit header, that contains information common to all events (such as the name of the event, the user responsible, the time and return status of the event), and the audit trail, which contains event-specific information. The audit logger appends each successive record to the kernel audit trail, which can be written in either (or both) of two modes:

### **BIN mode**

The trail is written into alternating files, providing for safety and long-term storage.

### **STREAM mode**

The trail is written to a circular buffer that is read synchronously through an audit pseudo-device. STREAM mode offers immediate response.

Information collection can be configured at both the front end (event recording) and at the back end (trail processing). Event recording is selectable on a per-user basis. Each user has a defined set of audit events that are logged in the audit trail when they occur. At the back end, the modes are individually configurable, so that the administrator can employ the back-end processing best suited for a particular environment. In addition, BIN mode auditing can be configured to generate an alert in case the file system space available for the trail is getting too low.

## Audit trail information processing

The operating system provides several options for processing the kernel audit trail. The BIN mode trail can be compressed, filtered, or formatted for output, or any reasonable combination of these before archival storage of the audit trail, if any. Compression is done through Huffman encoding. Filtering is done with standard query language (SQL)-like audit record selection (using the **auditselect** command), which provides for both selective viewing and selective retention of the audit trail. Formatting of audit trail records can be used to examine the audit trail, to generate periodic security reports, and to print a paper audit trail.

The STREAM mode audit trail can be monitored in real time, to provide immediate threat-monitoring capability. Configuration of these options is handled by separate programs that can be invoked as daemon processes to filter either BIN or STREAM mode trails, although some of the filter programs are more naturally suited to one mode or the other.

## Auditing subsystem configuration

The auditing subsystem has a global state variable that indicates whether the auditing subsystem is on. In addition, each process has a local state variable that indicates whether the auditing subsystem should record information about this process.

Both of these variables determine whether events are detected by the Trusted Computing Base (TCB) modules and programs. Turning TCB auditing off for a specific process allows that process to do its own auditing and not to bypass the system accountability policy. Permitting a trusted program to audit itself allows for more efficient and effective collection of information.



## Auditing subsystem information collection

Information collection addresses event selection and kernel audit trail modes. It is done by a kernel routine that provides interfaces to log information, used by the TCB components that detect auditable events, and configuration interfaces, used by the auditing subsystem to control the audit logging routine.

### Audit logging

Auditable events are logged by the following interfaces: the user state and supervisor state. The user state portion of the TCB uses the **auditlog** or **auditwrite** subroutine, while the supervisor state portion of the TCB uses a set of kernel procedure calls.

For each record, the audit event logger prefixes an audit header to the event-specific information. This header identifies the user and process for which this event is being audited, as well as the time of the event. The code that detects the event supplies the event type and return code or status and optionally, additional event-specific information (the event tail). Event-specific information consists of object names (for example, files that are refused access or tty used in failed login attempts), subroutine parameters, and other modified information.

Events are defined symbolically, rather than numerically. This lessens the chances of name collisions, without using an event registration scheme. Because subroutines are auditable and the extendable kernel definition has no fixed switched virtual circuit (SVC) numbers, it is difficult to record events by number. The number mapping would have to be revised and logged every time that the kernel interface was extended or redefined.

### Audit record format

The audit records consist of a common header, followed by audit trails specific to the audit event of the record. The structures for the headers are defined in the **/usr/include/sys/audit.h** file. The format of the information in the audit trails is specific to each base event and is shown in the **/etc/security/audit/events** file.

The information in the audit header is generally collected by the logging routine to ensure its accuracy, while the information in the audit trails is supplied by the code that detects the event. The audit logger has no knowledge of the structure or semantics of the audit trails. For example, when the **login** command detects a failed login, it records the specific event with the terminal on which it occurred and writes the record into the audit trail using the **auditlog** subroutine. The audit logger kernel component records the subject-specific information (user IDs, process IDs, time) in a header and appends this to the other information. The caller supplies only the event name and result fields in the header.

### Audit logger configuration

The audit logger is responsible for constructing the complete audit record. You must select the audit events that you want to be logged.

### Audit events selection

Audit event selection has the following types:

#### Per-Process Auditing

To select process events efficiently, the system administrator can define audit classes. An audit class is a subset of the base auditing events in the system. Auditing classes provide for convenient logical groupings of the base auditing events.

For each user on the system, the system administrator defines a set of audit classes that determine the base events that could be recorded for that user. Each process run by the user is tagged with its audit classes.

## **Per-Object Auditing**

The operating system provides for the auditing of object accesses by name; that is, the auditing of specific objects (normally files). By-name object auditing prevents having to cover all object accesses to audit the few pertinent objects. In addition, the auditing mode can be specified, so that only accesses of the specified mode (read/write/execute) are recorded.

## **Kernel audit trail modes**

Kernel logging can be set to BIN or STREAM modes to define where the kernel audit trail is to be written. If the BIN mode is used, the kernel audit logger must be given (before audit startup) at least one file descriptor to which records are to be appended.

BIN mode consists of writing the audit records into alternating files. At auditing startup, the kernel is passed two file descriptors and an advisory maximum bin size. It suspends the calling process and starts writing audit records into the first file descriptor. When the size of the first bin reaches the maximum bin size, and if the second file descriptor is valid, it switches to the second bin and reactivates the calling process. The kernel continues writing into the second bin until it is called again with another valid file descriptor. If at that point the second bin is full, it switches back to the first bin, and the calling process returns immediately. Otherwise, the calling process is suspended, and the kernel continues writing records into the second bin until it is full. Processing continues this way until auditing is turned off. See the following figure for an illustration of audit BIN mode:

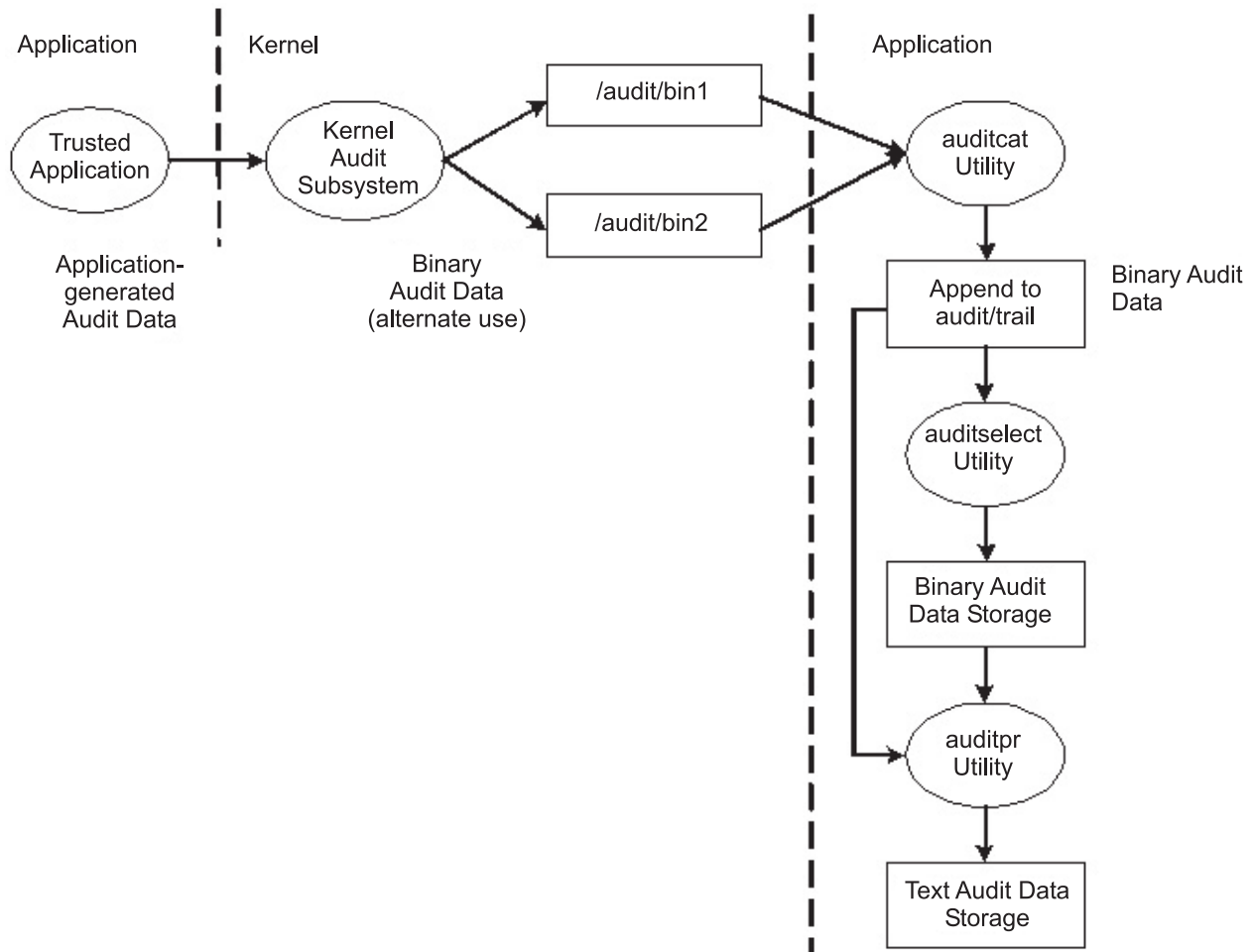

Figure 1. Process of the audit BIN mode.. This illustration shows the process of the audit BIN mode.

The alternating bin mechanism is used to ensure that the audit subsystem always has something to write to while the audit records are processed. When the audit subsystem switches to the other bin, it empties the first bin content to the **trace** file. When time comes to switch the bin again, the first bin is available. It decouples the storage and analysis of the data from the data generation. Typically, the **auditcat** program is used to read the data from the bin that the kernel is not writing to at the moment. To make sure that the system never runs out of space for the audit trail (the output of the **auditcat** program), the *freespace* parameter can be specified in the **/etc/security/audit/config** file. If the system has less than the amount of 512-byte blocks specified here, it generates a syslog message.

If auditing is enabled, the *binmode* parameter in the *start* stanza in **/etc/security/audit/config** should be set to *panic*. The *freespace* parameter in the *bin* stanza should be configured at minimum to a value that equals 25 percent of the disk space dedicated to the storage of the audit trails. The *bytethreshold* and *binsize* parameters should each be set to 65536 bytes.

In the STREAM mode, the kernel writes records into a circular buffer. When the kernel reaches the end of the buffer, it simply wraps to the beginning. Processes read the information through a pseudo-device called **/dev/audit**. When a process opens this device, a channel is created for that process. Optionally, the events to be read on the channel can be specified as a list of audit classes. See the following figure for an illustration of audit STREAM mode:

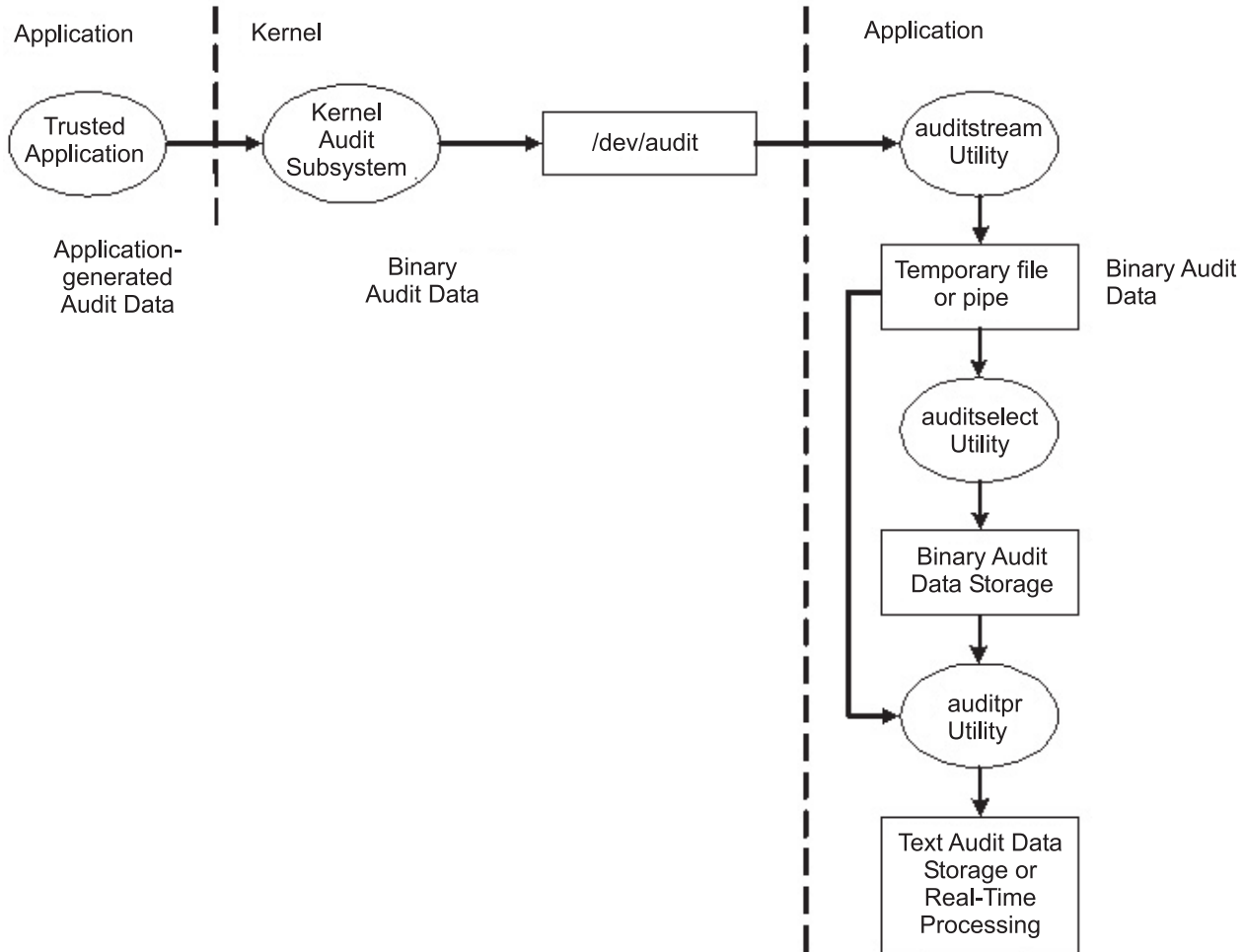

Figure 2. Process of the audit STREAM mode. This illustration shows the process of the audit STREAM mode.

The main purpose of the STREAM mode is to allow for timely reading of the audit trail, which is desirable for real-time threat monitoring. Another use is to create a trail that is written immediately, preventing any possible tampering with the audit trail, as is possible if the trail is stored on some writable media.

Yet another method to use the STREAM mode is to write the audit stream into a program that stores the audit information on a remote system, which allows central near-time processing, while at the same time protecting the audit information from tampering at the originating host.

## Audit records processing

The **auditselect**, **auditpr**, and **auditmerge** commands are available to process BIN or STREAM mode audit records. Both utilities operate as filters so that they can be easily used on pipes, which is especially handy for STREAM mode auditing.

### auditselect

Can be used to select only specific audit records with SQL-like statements. For example, to select only **exec()** events that were generated by user *afx*, type the following:

```
auditselect -e "login==afx && event==PROC_Execute"
```

## auditpr

Used to convert the binary audit records into a human-readable form. The amount of information displayed depends on the flags specified on the command line. To get all the available information, run the **auditpr** command as follows:

```
auditpr -v -hhe1rtRpPTc
```

When the **-v** flag is specified, the audit tail which is an event specific string (see the **/etc/security/audit/events** file) is displayed in addition to the standard audit information that the kernel delivers for every event.

## auditmerge

Used to merge binary audit trails. This is especially useful if there are audit trails from several systems that need to be combined. The **auditmerge** command takes the names of the trails on the command line and sends the merged binary trail to standard output, so you still need to use the **auditpr** command to make it readable. For example, the **auditmerge** and **auditpr** commands could be run as follows:

```
auditmerge trail.system1 trail.system2 | auditpr -v -hhe1rRtpc
```

### **Using the audit subsystem for a quick security check:**

To monitor a single suspicious program without setting up the audit subsystem, the **watch** command can be used. It will record either the requested or all events that are generated by the specified program.

For example, to see all **FILE\_Open** events when running **vi /etc/hosts**, type the following:

```
watch -eFILE_Open -o /tmp/vi.watch vi /etc/hosts
```

The **/tmp/vi.watch** file displays all **FILE\_Open** events for the editor session.

## Event selection

Event selection must maintain a balance between insufficient to too much detail.

The set of auditable events on the system defines which occurrences can actually be audited and the granularity of the auditing provided. The auditable events must cover the security-relevant events on the system, as defined previously. The level of detail you use for auditable event definition must maintain a balance between insufficient detail, which makes it difficult for the administrator to understand the selected information, and too much detail, which leads to excessive information collection. The definition of events takes advantage of similarities in detected events. For the purpose of this discussion, a *detected event* is any single instance of an auditable event; for instance, a given event might be detected in various places. The underlying principle is that detected events with similar security properties are selected as the same auditable event. The following list shows a classification of security policy events:

- Subject Events
  - Process creation
  - Process deletion
  - Setting subject security attributes: user IDs, group IDs
  - Process group, control terminal
- Object Events
  - Object creation
  - Object deletion
  - Object open (including processes as objects)
  - Object close (including processes as objects)
  - Setting object security attributes: owner, group, ACL
- Import/Export Events
  - Importing or exporting an object

- Accountability Events
  - Adding a user, changing user attributes in the password database
  - Adding a group, changing group attributes in the group database
  - User login
  - User logoff
  - Changing user authentication information
  - Trusted path terminal configuration
  - Authentication configuration
  - Auditing administration: selecting events and audit trails, switching on or off, defining user auditing classes
- General System Administration Events
  - Use of privilege
  - File system configuration
  - Device definition and configuration
  - System configuration parameter definition
  - Normal system IPL and shutdown
  - RAS configuration
  - Other system configuration
  - Starting the audit subsystem
  - Stopping the audit subsystem
  - Querying the audit subsystem
  - Resetting the audit subsystem
- Security Violations (potential)
  - Access permission refusals
  - Privilege failures
  - Diagnostically detected faults and system errors
  - Attempted alteration of the TCB

## Setting up auditing

This procedure shows you how to set up an auditing subsystem. For more specific information, refer to the configuration files noted in these steps.

1. Select system activities (events) to audit from the list in the **/etc/security/audit/events** file. If you have added new audit events to applications or kernel extensions, you must edit the file to add the new events.
  - You add an event to this file if you have included code to log that event in an application program (using the **auditwrite** or **auditlog** subroutine) or in a kernel extension (using the **audit\_svcstart**, **audit\_svcbcopy**, and **audit\_svcfinis** kernel services).
  - Ensure that formatting instructions for any new audit events are included in the **/etc/security/audit/events** file. These specifications enable the **auditpr** command to write an audit trail when it formats audit records.
2. Group your selected audit events into sets of similar items called *audit classes*. Define these audit classes in the classes stanza of the **/etc/security/audit/config** file.
3. Assign the audit classes to the individual users and assign audit events to the files (objects) that you want to audit, as follows:
  - To assign audit classes to an individual user, add a line to the users stanza of the **/etc/security/audit/config** file. To assign audit classes to a user, you can use the **chuser** command.
  - To assign audit events to an object (data or executable file), add a stanza for that file to the **/etc/security/audit/objects** file.

- You can also specify default audit classes for new users by editing the **/usr/lib/security/mkuser.default** file. This file holds user attributes that will be used when generating new user IDs. For example, use the general audit class for all new user IDs, as follows:

```
user:
 auditclasses = general
 pgrp = staff
 groups = staff
 shell = /usr/bin/ksh
 home = /home/$USER
```

To get all audit events, specify the ALL class. When doing so on even a moderately busy system, a huge amount of data will be generated. It is typically more practical to limit the number of events that are recorded.

4. In the **/etc/security/audit/config** file, configure the type of data collection that you want using BIN collection, STREAM collection, or both methods. Make sure that audit data does not compete with other data about file space by using a separate file system for audit data. This ensures that there is enough space for the audit data. Configure the type of data collection as follows:
  - To configure BIN collection:
    - a. Enable the BIN mode collection by setting `binmode = on` in the start stanza.
    - b. Edit the binmode stanza to configure the bins and trail, and specify the path of the file containing the BIN mode back-end processing commands. The default file for back-end commands is the **/etc/security/audit/bincmds** file.
    - c. Make sure that the audit bins are large enough for your needs and set the *freespace* parameter accordingly to get an alert if the file system is filling up.
    - d. Include the shell commands that process the audit bins in an audit pipe in the **/etc/security/audit/bincmds** file.
  - To configure STREAM collection:
    - a. Enable the STREAM mode collection by setting `streammode = on` in the start stanza.
    - b. Edit the streammode stanza to specify the path to the file containing the streammode processing commands. The default file containing this information is the **/etc/security/audit/streamcmds** file.
    - c. Include the shell commands that process the stream records in an audit pipe in the **/etc/security/audit/streamcmds** file.
5. When you have finished making any necessary changes to the configuration files, you are ready to use the **audit start** command to enable the audit subsystem. This will generate the **AUD\_It** event with a value of 1.
6. Use the **audit query** command to see which events and objects are audited. This will generate the **AUD\_It** event with a value of 2.
7. Use the **audit shutdown** command to deactivate the audit subsystem again. This will generate the **AUD\_It** event with a value of 0.

### **Generating a generic audit log:**

The following are examples of generating a generic audit log.

In this example, assume that a system administrator wants to use the audit subsystem to monitor a large multi-user server system. No direct integration into an IDS is performed, all audit records will be inspected manually for irregularities. Only a few essential audit events are recorded, to keep the amount of generated data to a manageable size.

The audit events that are considered for event detection are the following:

|            |                                                                                                                              |
|------------|------------------------------------------------------------------------------------------------------------------------------|
| FILE_Write | We want to know about file writes to configuration files, so this event will be used with all files in the <b>/etc</b> tree. |
|------------|------------------------------------------------------------------------------------------------------------------------------|

|                 |                                                             |
|-----------------|-------------------------------------------------------------|
| PROC_SetUserIDs | All changes of user IDs                                     |
| AUD_Bin_Def     | Audit bin configuration                                     |
| USER_SU         | The <b>su</b> command                                       |
| PASSWORD_Change | <b>passwd</b> command                                       |
| AUD_Lost_Rec    | Notification in case there where lost records               |
| CRON_JobAdd     | new cron jobs                                               |
| AT_JobAdd       | new at jobs                                                 |
| USER_Login      | All logins                                                  |
| PORT_Locked     | All locks on terminals because of too many invalid attempts |

The following is an example of how to generate a generic audit log:

1. Set up a list of critical files to be monitored for changes, such as, all files in **/etc** and configure them for **FILE\_Write** events in the **objects** file as follows:

```
find /etc -type f | awk '{printf("%s:\n\tw = FILE_Write\n\n", $1)}' >> /etc/security/audit/objects
```

2. Use the **auditcat** command to set up BIN mode auditing. The **/etc/security/audit/bincmds** file is similar to the following:

```
/usr/sbin/auditcat -p -o $trail $bin
```

3. Edit the **/etc/security/audit/config** file and add a class for the events we have interest. List all existing users and specify the custom class for them.

```
start:
 binmode = on
 streammode = off

bin:
 cmds = /etc/security/audit/bincmds
 trail = /audit/trail
 bin1 = /audit/bin1
 bin2 = /audit/bin2
 binsize = 100000
 freespace = 100000

classes:
 custom = FILE_Write,PROC_SetUser,AUD_Bin_Def,AUD_Lost_Rec,USER_SU, \
 PASSWORD_Change,CRON_JobAdd,AT_JobAdd,USER_Login,PORT_Locked

users:
 root = custom
 afx = custom
 ...
```

4. Add the custom audit class to the **/usr/lib/security/mkuser.default** file, so that new IDs will automatically have the correct audit call associated:

```
user:
 auditclasses = custom
 pgrp = staff
 groups = staff
 shell = /usr/bin/ksh
 home = /home/$USER
```

5. Create a new file system named **/audit** by using SMIT or the **crfs** command. The file system should be large enough to hold the two bins and a large audit trail.
6. Run the **audit start** command option and examine the **/audit** file. You should see the two bin files and an empty **trail** file initially. After you have used the system for a while, you should have audit records in the **trail** file that can be read with:

```
auditpr -hhelpPRtTc -v | more
```

This example uses only a few events. To see all events, you could specify the classname ALL for all users. This action will generate large amounts of data. You might want to add all events related to user changes and privilege changes to your custom class.



### **Monitoring file access to critical files in real time:**

These steps can be used to monitor file access to critical files in real time.

Perform these steps:

1. Set up a list of critical files to be monitored for changes, for example all files in **/etc** and configure them for **FILE\_Write** events in the **objects** file:

```
find /etc -type f | awk '{printf("%s:\n\tw = FILE_Write\n\n",$1)}' >> /etc/security/audit/objects
```

2. Set up stream auditing to list all file writes. (This example lists all file writes to the console, but in a production environment you might want to have a backend that sends the events into an Intrusion Detection System.) The **/etc/security/audit/streamcmds** file is similar to the following:

```
/usr/sbin/auditstream | /usr/sbin/auditselect -e "event == FILE_Write" |
auditpr -hhelppRtTc -v > /dev/console &
```

3. Set up STREAM mode auditing in **/etc/security/audit/config**, add a class for the file write events and configure all users that should be audited with that class:

```
start:
 binmode = off
 streammode = on

stream:
 cmds = /etc/security/audit/streamcmds

classes:
 filemon = FILE_write

users:
 root = filemon
 afx = filemon
 ...
```

4. Now run **audit start**. All **FILE\_Write** events are displayed on the console.

### **Audit events selection:**

The purpose of an audit is to detect activities that might compromise the security of your system.

When performed by an unauthorized user, the following activities violate system security and are candidates for an audit:

- Engaging in activities in the Trusted Computing Base
- Authenticating users
- Accessing the system
- Changing the configuration of the system
- Circumventing the auditing system
- Initializing the system
- Installing programs
- Modifying accounts
- Transferring information into or out of the system

The audit system does not have a default set of events to be audited. You must select events or event classes according to your needs.

To audit an activity, you must identify the command or process that initiates the audit event and ensure that the event is listed in the **/etc/security/audit/events** file for your system. Then you must add the event either to an appropriate class in the **/etc/security/audit/config** file, or to an object stanza in the

**/etc/security/audit/objects** file. See the **/etc/security/audit/events** file on your system for the list of audit events and trail formatting instructions. For a description of how audit event formats are written and used, see the **auditpr** command.

After you have selected the events to audit, you must combine similar events into audit classes. Audit classes are then assigned to users.

### Audit classes selection

You can facilitate the assignment of audit events to users by combining similar events into audit classes. These audit classes are defined in the classes stanza of the **/etc/security/audit/config** file.

Some typical audit classes might be as follows:

|                |                                                                                                                                |
|----------------|--------------------------------------------------------------------------------------------------------------------------------|
| <b>general</b> | Events that alter the state of the system and change user authentication. Audit attempts to circumvent system access controls. |
| <b>objects</b> | Write access to security configuration files.                                                                                  |
| <b>kernel</b>  | Events in the kernel class are generated by the process management functions of the kernel.                                    |

An example of a stanza in the **/etc/security/audit/config** file is as follows:

```
classes:
 general = USER_SU,PASSWORD_Change,FILE_Unlink,FILE_Link,FILE_Rename
 system = USER_Change,GROUP_Change,USER_Create,GROUP_Create
 init = USER_Login,USER_Logout
```

### Audit data-collection method selection

Your selection of a data-collection method depends on how you intend to use the audit data. If you need long-term storage of a large amount of data, select BIN collection. If you want to process the data as it is collected, select STREAM collection. If you need both long-term storage and immediate processing, select both methods.

|                          |                                                                                                                                                                                                                                                                                                                              |
|--------------------------|------------------------------------------------------------------------------------------------------------------------------------------------------------------------------------------------------------------------------------------------------------------------------------------------------------------------------|
| <b>Bin collection</b>    | Allows storage of a large audit trail for a long time. Audit records are written to a file that serves as a temporary bin. After the file is filled, the data is processed by the <b>auditbin</b> daemon while the audit subsystem writes to the other bin file, and records are written to an audit trail file for storage. |
| <b>Stream collection</b> | Allows processing of audit data as it is collected. Audit records are written into a circular buffer within the kernel, and are retrieved by reading <b>/dev/audit</b> . The audit records can be displayed, printed to provide a paper audit trail, or converted into bin records by the <b>auditcat</b> command.           |

## Light Directory Access Protocol

The Light Directory Access Protocol (LDAP) defines a standard method for accessing and updating information in a directory (a database) either locally or remotely in a client-server model.

The protocol is optimized for reading, browsing, and searching directories, and was originally developed as a lightweight front-end to the X.500 Directory Access Protocol. The LDAP method is used by a cluster of hosts to allow centralized security authentication as well as access to user and group information. This functionality is intended to be used in a clustering environment to keep authentication, user, and group information common across the cluster.

Objects in LDAP are stored in a hierarchical structure known as a Directory Information Tree (DIT). A good directory starts with the structural design of the DIT. The DIT should be designed carefully before implementing LDAP as a means of authentication.

## LDAP authentication load module

The LDAP exploitation of the security subsystem is implemented as the LDAP authentication load module. It is conceptually similar to the other load modules such as NIS, DCE, and KRB5. Load modules are defined in the `/usr/lib/security/methods.cfg` file.

The LDAP loadmodule provides user authentication and centralized user and group management functionality through the LDAP protocol. A user defined on a LDAP server can be configured to log in to an LDAP client even if that user is not defined locally.

The AIX LDAP load module is fully integrated within the AIX operating system. After the LDAP authentication load module is enabled to serve user and group information, high-level APIs, commands, and system-management tools work in their usual manner. An **-R** flag is introduced for most high-level commands to work through different load modules. For example, to create an LDAP user named *joe* from a client machine, use the following command:

```
mkuser -R LDAP joe
```

**Note:** Even though the LDAP infrastructure can support an unlimited number of users in a group, up to 25 000 users have been created in a single group and various operations tested against that group. Some of the historical POSIX interfaces might not return the complete information for the group. Refer to the individual API's documentation for such limitations.

### ***LDAP based authentication:***

There are limits on the various entities as part of LDAP based authentication on AIX.

Note that LDAP infrastructure itself does not specify any limits on the database contents. However, this section documents the results based on test configurations as to limits. The following limits have been tested with respect to the LDAP based authentication on AIX:

**Total number of users:** Up to 500 000 users have been created on a single system and simultaneous authentication has been tested for hundreds of users.

**Total number of groups:** Up to 500 groups have been created on a single system and tested.

**Maximum number of users per group:** Up to 25 000 users have been created in a single group and various operations tested against that group.

Some of the historical POSIX interfaces might not return the complete information for the group. Refer to the individual API's documentation for such limitations. Also, the above values are based on the testing done. They do not preclude the possibility that one can configure systems with much larger users and groups provided necessary resources exist.

### ***Setting up an ITDS security information server:***

To set up a system as an LDAP security information server that serves authentication, user, and group information through LDAP, the LDAP server and client packages must be installed.

If the Secure Socket Layer (SSL) is required, the **GSKit** package must be installed. The system administrator must create a key using the **keyman** command. For more information about configuring the server to use SSL, see Secure Communication with SSL.

To simplify server configuration, AIX created the **mksecldap** command. The **mksecldap** command can be used to set up an LDAP security information server. It sets up a database named *ldapdb2*, populates the database with the user and group information from the local host, and sets the LDAP server administrator DN (distinguished name) and password. Optionally, it can set up SSL for client/server communication. The **mksecldap** command adds an entry into the `/etc/inittab` file to start the LDAP server at every reboot. The

entire LDAP server setup is done through the **mksecdap** command, which updates the **ibmslapd.conf** file (IBM Tivoli® Directory Server Version 5.1 and later) or **slapd.conf** file (SecureWay® Directory Version 3.2 and 4.1) or **slapd32.conf** file (SecureWay Directory Version 3.2).

Unless the **-u NONE** command option for **mksecdap** is used, all users and groups from the local system are exported to the LDAP server during setup. Select one of the following LDAP schemas for this step:

#### **AIX schema**

Includes **aixAccount** and **aixAccessGroup** object class. This schema offers a full set of attributes for AIX users and groups.

#### **RFC 2307 schema**

Includes **posixAccount**, **shadowAccount**, and **posixGroup** object class and is used by several vendors' directory products. The RFC 2307 schema defines only a small subset of attributes that AIX uses.

#### **RFC2307AIX schema**

Includes **posixAccount**, **shadowAccount**, and **posixGroup** object classes plus the **aixAuxAccount** and **aixAuxGroup** object classes. The **aixAuxAccount** and **aixAuxGroup** object classes provide the attributes which are used by AIX but not defined by the RFC 2307 schema.

Using the RFC2307AIX schema type for users and groups is highly recommended. The RFC2307AIX schema type is fully compliant to RFC 2307 with extra attributes to support additional AIX user management functionality. An ITDS server with RFC2307AIX schema configuration not only supports AIX LDAP clients, but also other RFC 2307 compliant UNIX and Linux® LDAP clients.

AIX 5.1 and earlier requires AIX schema type. Use of AIX schema type is not encouraged unless such a server is required to support systems with AIX 5.1 and earlier. Non-AIX systems might not work with ITDS with AIX schema for user and group management.

All the user and group information is stored under a common AIX tree (suffix). The default suffix is "cn=aixdata". The **mksecdap** command accepts a user-supplied suffix through the **-d** flag. The name for the subtrees to be created for the user, group, ID, and so on is controlled by the **sectoldif.cfg** configuration file. Refer to the **sectoldif.cfg** file for more information.

The created AIX tree is ACL (Access Control List) protected. The default ACL grants administrative privilege only to the entity specified as the administrator with the **-a** command option. Additional privilege can be granted to a proxy identity if the **-x** and **-X** command options are used. Use of these options creates the proxy identity and configure access privilege as defined in the **/etc/security/ldap/proxy.ldif.template** file. Creation of a proxy identity allows LDAP clients to bind to the server without the use of the administrator identity, thereby restricting client administrator privileges on the LDAP server.

The **mksecdap** command works even if an LDAP server has been set up for other purposes; for example, for user ID lookup information. In this case, **mksecdap** adds the AIX tree and populates it with the AIX security information to the existing database. This tree is ACL-protected independently from other trees. In this case, the LDAP server works as usual, in addition to serving as an AIX LDAP Security Server.

**Note:** Back up the existing database before running the **mksecdap** command to set up the security server to share the same database is recommended.

After the LDAP security information server is successfully set up, the same host can also be set up as a client so that LDAP user and group management can be completed and LDAP users can log in to this server.

If the LDAP security information server setup is not successful, you can undo the setup by running the **mksecdap** command with the **-U** flag. This restores the **ibmslapd.conf** (or **slapd.conf** or **slapd32.conf**)

file to its pre-setup state. Run the **mksecldap** command with the **-U** flag after any unsuccessful setup attempt before trying to run the **mksecldap** command again. Otherwise, residual setup information might remain in the configuration file and cause a subsequent setup to fail. As a safety precaution, the **undo** option does not do anything to the database or to its data, because the database could have existed before the **mksecldap** command was run. Remove any database manually if it was created by the **mksecldap** command. If the **mksecldap** command has added data to a pre-existing database, decide what steps to take to recover from a failed setup attempt.

For more information on setting up an LDAP security information server, see the **mksecldap** command.

### **Setting up an LDAP client:**

To set up a client to use LDAP for authentication and user/group information, make sure that each client has the LDAP client package installed. If the SSL is required, the GSKit must be installed, a key must be created, and the LDAP server SSL key certificate must be added to this key.

Similar to LDAP server setup, client setup can be done using the **mksecldap** command. To have this client contact the LDAP security information server, the server name must be supplied during setup. The server's bind DN and password are also needed for client access to the AIX tree on the server. The **mksecldap** command saves the server bind DN, password, server name, AIX tree DN on the server, the SSL key path and password, and other configuration attributes to the **/etc/security/ldap/ldap.cfg** file.

The **mksecldap** command saves the bind password and SSL key password (if configuring SSL) to the **/etc/security/ldap/ldap.cfg** file in encrypted format. The encrypted passwords are system specific, and can only be used by the **secldapclntd** daemon on the system where they are generated. The **secldapclntd** daemon can make use of clear text or encrypted password from the **/etc/security/ldap/ldap.cfg** file.

Multiple servers can be supplied to the **mksecldap** command during client setup. In this case, the client contacts the servers in the supplied order and establishes connection to the first server that the client can successfully bind to. If a connection error occurs between the client and the server, a reconnection request is tried using the same logic. The Security LDAP exploitation model does not support referral. It is important that the replicate servers are kept synchronized.

The client communicates to the LDAP security information server through a client side daemon (**secldapclntd**). If the LDAP load module is enabled on the client, high-level commands are routed to the daemon through the library APIs for users defined in LDAP. The daemon maintains a cache of requested LDAP entries. If a request is not satisfied from the cache, the daemon queries the server, updates the cache, and returns the information back to the caller.

Other fine-tuning options can be supplied to the **mksecldap** command during client setup, such as settings for the number of threads used by the daemon, the cache entry size, and the cache expiration timeout. These options are for experienced users only. For most environments, the default values are sufficient.

In the final steps of the client setup, the **mksecldap** command starts the client-side daemon and adds an entry in the **/etc/inittab** file so the daemon starts at every reboot. You can check whether the setup is successful by checking the **secldapclntd** daemon process through the **ls-secldapclntd** command. Provided that the LDAP security information server is setup and running, this daemon will be running if the setup was successful.

The server must be set up before the client. Client setup depends on the migrated data being on the server. Follow these steps to set up the client:

1. Install **ldap.client** fileset on the AIX 5.3 system.
2. To configure the LDAP client, run the following command:

```
mksecdap -c -h server1.ibm.com -a cn=admin -p adminpwd -d cn=basedn
```

Replace the values above as appropriate for your environment.

See the **mksecdap** command description in *AIX Version 6.1 Commands Reference* for more details.

#### *Client enablement for LDAP netgroups:*

You can use netgroups as part of NIS-LDAP (the name-resolution method).

Perform the following steps for client enablement for LDAP netgroups:

1. Install and set up LDAP based user group management as detailed in `../../../../com.ibm.aix.security/doc/security/ldap_client_setup.htm`.

If the netgroup setup is not completed, any LDAP-defined user will be listed by the system. For example, if *nguser* is a netgroup user belonging to netgroup *mygroup* already defined in the LDAP server, `lsuser -R LDAP nguser` will list the user.

2. To enable the netgroup function, the module definition for LDAP in the `/usr/lib/security/methods.cfg` file needs to include an options attribute with a netgroup value. Edit the `/usr/lib/security/methods.cfg` file and add the line `options = netgroup` to the LDAP stanza. This marks the LDAP load module as a netgroup-capable load module. For example:

```
LDAP:
 program = /usr/lib/security/LDAP
 program_64 = /usr/lib/security/LDAP64
 options = netgroup
```

Now the commands `lsuser -R LDAP nguser`, or `lsuser nguser` or `lsuser -R LDAP -a ALL` do not list any users. LDAP is now considered a netgroup-only database from this client and no netgroups have been enabled for access to this client yet.

3. Edit the `/etc/passwd` file, and append a line for the netgroup that should have access to the system. For example if *mygroup* is a netgroup on the LDAP server that contains the desired user, append the following:

```
+@mygroup
```

4. Edit the `/etc/group` file and append a `+:`  line to enable NIS lookups for groups:

```
+:
```

Running the command `lsuser nguser` now returns the user because *nguser* is in the netgroup *mygroup*.

The `lsuser -R LDAP nguser` command does not find the user, but the command `lsuser -R compat nguser` does because the user is considered a **compat** user now.

5. In order for netgroup users to authenticate to the system, the AIX authentication mechanism must know the method to use. If the default stanza in the `/etc/security/user` file includes `SYSTEM = compat`, then all netgroup users in the netgroup added to the `/etc/passwd` file can authenticate. Another option would be to individually configure users by manually adding stanzas to the `/etc/security/user` file for the desired users. An example stanza for *nguser* is:

```
nguser:
 SYSTEM = compat
 registry = compat
```

Netgroup users in the allowed netgroups can now authenticate to the system.

Enabling the netgroup feature also activates the following conditions:

- Users defined in the `/etc/security/user` file as members of the LDAP registry (having `registry=LDAP` and `SYSTEM="LDAP"`) cannot authenticate as LDAP users. These users are now **nis\_ldap** users and require native NIS netgroup membership.

- The meaning of registry compat is expanded to include modules that use netgroup. For example, if LDAP module is netgroup enabled, compat includes the files, NIS, and LDAP registries. Users retrieved from those modules have a registry value of compat.

### **Related information**

- The exports File for NFS document
- The .rhosts File Format for TCP/IP document
- The hosts.equiv File Format for TCP/IP document

### **Supported LDAP servers:**

AIX LDAP-based user and group management supports IBM Tivoli Directory Servers, non IBM servers with RFC 2307 compliant schema, and Microsoft® active directory servers.

### **IBM Tivoli Directory Server**

It is highly recommended that AIX user/group management be configured using IBM Tivoli Directory Servers (ITDS) servers. For more information about setting up an ITDS server for user and group management, see Setting up an ITDS security information server.

### **Non IBM Directory Servers**

AIX supports a variety of directory servers whose users and groups are defined using the RFC 2307 schema. When configured as an LDAP client to such servers, AIX uses the servers the same way as an ITDS server with RFC 2037 schema. These servers must support LDAP Version 3 protocol.

Because the RFC 2307 schema only defines a subset of user and group attributes that AIX can use, some AIX user and group management functionality could not be done if AIX is configured to use such an LDAP server (for example, user password reset enforcement, password history, per user resource limit, login control to certain systems through the AIX `hostsallowedlogin` and `hostsdeniedlogin` attributes, capability, and so on).

AIX does not support non-RFC 2307 compliant directory servers. However, AIX may be made to work with such servers that are not RFC 2307 compliant, but whose users and groups are defined with all the required UNIX attributes. The minimal set of user and group attributes required by AIX is the set defined in RFC 2307. Support for such directory servers requires manual configuration. AIX provides a schema mapping mechanism for this purpose. For more information on schema file format and schema file usage, see LDAP Attribute Mapping File Format.

### **Microsoft Active Directory**

AIX supports Microsoft Active Directory (AD) as an LDAP server for user and group management. The AD server must have the UNIX supporting schema installed. The UNIX support schema of AD comes from the Microsoft Service For UNIX (SFU) package. Each SFU version has slightly different user and group schema definitions from its predecessors. AIX supports AD running on Windows® 2000 and 2003 with SFU schema Version 3.0 and 3.5, and AD running on Windows 2003 R2 with its built in UNIX schema.

Due to the difference in user and group management between UNIX systems and Windows systems, not all AIX commands may work on LDAP users if the server is AD. Commands that do not work include **mkuser** and **mkgroup**. Most user and group management commands do work, depending on the access rights given to the identity with which AIX binds to AD. These commands include **lsuser**, **chuser**, **rmuser**, **lsgroup**, **chgroup**, **rmgroup**, **id**, **groups**, **passwd**, and **chpasswd**.

AIX supports two user authentication mechanisms against Windows servers: LDAP authentication and Kerberos authentication. With either mechanism, AIX supports user identification through LDAP protocol

against AD, with no requirement for a corresponding user account on AIX.

#### *Configuring AIX to work with Active Directory through LDAP:*

AIX supports Microsoft Active Directory (AD) as an LDAP server for user and group management. It is required that the AD server has the UNIX supporting schema installed.

An administrator can use the **mksecdap** command to configure AIX on the AD server in the same manner as an ITDS server. The **mksecdap** command hides all the details of configuration to simplify the process. Before running the **mksecdap** command to configure AIX on the AD server:

1. The AD server must have the UNIX support schema installed.
2. The AD server must contain users which are UNIX enabled.

For more information about installing UNIX schema to AD and enabling AD users with UNIX support, see the related Microsoft documentation.

The AD schema often has multiple attribute definitions for the same UNIX attribute (for example, there are multiple user password and group member definitions). Although AIX supports most of them, consideration and planning should be done carefully when selecting the definitions to use. It is recommended that AIX systems and other non-AIX systems sharing the same AD use the same definition to avoid conflicts.

#### *Active Directory password attribute selection:*

AIX supports two authentication mechanisms, **unix\_auth** and **ldap\_auth**.

With **unix\_auth**, the password in Microsoft Active Directory (AD) is required to be in encrypted format. During authentication, the encrypted password is retrieved from AD and compared to the encrypted format of the user-entered password. Authentication is successful if they match. In **ldap\_auth** mode, AIX authenticates a user by an LDAP bind operation to the server with the user's identity and the supplied password. The user is authenticated if the bind operation is successful. AD supports multiple user password attributes. A different AIX authentication mode requires a different AD user password attribute.

#### **unix\_auth mode**

The following AD password attributes can be used for **unix\_auth** mode:

- **userPassword**
- **unixUserPassword**
- **msSFU30Password**

Password management on AIX can be difficult due to AD's multiple password attributes. Knowing which password management attributes should be used by the UNIX clients can be confusing. AIX LDAP attribute mapping capability enables you to customize the password management according to your needs.

By default, AIX uses the **msSFU30Password** attribute for AD running on Windows 2000 and 2003, and the **userPassword** attribute on Windows 2003 R2. If a different password is used, you need to modify the **/etc/security/ldap/sfu30user.map** file (or the **/etc/security/ldap/sfur2user.map** file if AD is running on Windows 2003 R2). Find the line that starts with the word **spassword** and change the third field of the line to the desired AD password attribute name. For more information, see LDAP Attribute Mapping File Format. Run the **mksecdap** command to configure the AIX LDAP client after the change. If the AIX LDAP client is already configured, run the **restart-secdapclntd** command to restart the **secdapclntd** daemon to absorb the change.

In **unix\_auth** mode, the password might be out of sync between Windows and UNIX, resulting in a different password for each system. This occurs when you change a password from AIX to Windows, because Windows uses the **unicodepwd** password attribute. The AIX **passwd** command can reset the



UNIX password to be the same as a Windows password, but AIX does not support automatically changing the Window's password when you change your UNIX password from AIX.

### **ldap\_auth mode**

Active Directory also has the **unicodepwd** password attribute. This password attribute is used by Windows systems to authenticate Windows users. In a bind operation to AD, the **unicodePwd** password must be used. None of the passwords mentioned under **unix\_auth** mode works for a bind operation. If the **ldap\_auth** option is specified from the command line, the **mksecdap** command maps the password attribute to AD's **unicodePwd** attribute at client configuration with no manual step required.

By mapping AIX passwords with the **unicodePwd** attribute, users defined in AD can login to Windows and AIX systems using the same password. A password reset from either a AIX or Windows system is in effect for both AIX and Windows systems.

*Active Directory group member attribute selection:*

Microsoft's Service for UNIX defines the **memberUid**, **msSFU30MemberUid**, and **msSFU30PosixMember** group member attributes.

The **memberUid** and **msSFU30MemeberUid** attributes accept user account names, while the **msSFU30PosixMember** accepts only full DN. For example, for a user account *foo* (with last name *bar*) defined in AD:

- **memberUid: foo**
- **msSFU30MemberUid: foo**
- **msSFU30PosixMember: CN=foo bar,CN=Users,DC=austin,DC=ibm,DC=com**

AIX supports all of these attributes. Consult with your AD administrator to determine which attribute to use. By default, the **mksecdap** command configures AIX to use the **msSFU30PosixMember** attribute against AD running on Windows 2000 and 2003, and the **uidMember** attribute against AD running on Windows 2003 R2. Such selection is due to the AD behavior as AD selects that attribute when adding a user to a group from Windows. Your business strategy might require the use of a non-default group member attribute for supporting multiple platforms.

If a different group member attribute is needed, you can change the mapping by editing the group mapping file. The group mapping file for AD is **/etc/security/ldap/sfu30group.map** running on Windows 2000 and 2003, and **/etc/security/ldap/sfur2group.map** for Windows 2003 R2. Find the line that starts with the word **users**, and replace the third field with the desired attribute name for group members. For more information, see LDAP Attribute Mapping File Format. Run the **mksecdap** command to configure AIX LDAP client after the change, or if the AIX is already configured, run the **restart-secdapclntd** command to restart the **secdapclntd** daemon to absorb the change.

*Multiple organizational units:*

Your AD server might have multiple organizational units defined, with each containing a set of users.

Most Windows AD users are defined in the **cn=users,...** subtree, but some may be defined elsewhere. The AIX multiple base DN feature can be used for such an AD server. For more information, see Multiple base DN support.

*Kerberos authentication for Windows servers:*

In addition to the LDAP authentication mechanisms, AIX also supports user authentication through the Kerberos protocol for Windows servers.

AIX supports Kerberos authentication for Windows KDC and LDAP identification for Windows Active Directory by creating a KRB5ALDAP compound loadmodule. Because user identification information is pulled from Microsoft Active Directory, you do not need to create the corresponding user accounts on AIX.

### **LDAP user management:**

You can manage users and groups on an LDAP security information server from any LDAP client by using high-level commands.

An **-R** flag added to most of the high-level commands can manage users and groups using LDAP as well as other authentication load modules such as DCE, NIS, and KRB5. For more information concerning the use of the **-R** flag, refer to each of the user or group management commands.

To enable a user to authenticate through LDAP, run the **chuser** command to change the user's **SYSTEM** attribute value to LDAP. By setting the **SYSTEM** attribute value according to the defined syntax, a user can be authenticated through more than one load module (for example, compat and LDAP). For more information on setting users' authentication methods, see "User authentication" on page 65 and the **SYSTEM** attribute syntax defined in the **/etc/security/user** file.

A user can become an LDAP user at client setup time by running the **mksecldap** command with the **-u** flag in either of the following forms:

1. Run the command:

```
mksecldap -c -u user1,user2,...
```

where *user1,user2,...* is a list of users. The users in this list can be either locally defined or remote LDAP-defined users. The **SYSTEM** attribute is set to LDAP in each of the above users' stanzas in the **/etc/security/user** file. Such users are only authenticated through LDAP. The users in this list must exist on the LDAP security information server; otherwise, they can not log in from this host. Run the **chuser** command to modify the **SYSTEM** attribute and allow authentication through multiple methods (for example, both local and LDAP).

2. Run

```
mksecldap -c -u ALL
```

This command sets the **SYSTEM** attribute to LDAP in each user's stanza in the **/etc/security/user** file for all locally defined users. All such users only authenticate through LDAP. The locally defined users must exist on the LDAP security information server; otherwise they can not log in from this host. A user that is defined on the LDAP server but not defined locally cannot log in from this host. To allow a remote LDAP-defined user to log in from this host, run the **chuser** command to set the **SYSTEM** attribute to LDAP for that user.

Alternatively, you can enable all LDAP users, whether they are defined locally or not, to authenticate through LDAP on a local host by modifying the "default" stanza of the **/etc/security/user** file to use "LDAP" as its value. All users that do not have a value defined for their **SYSTEM** attribute must follow what is defined in the default stanza. For example, if the default stanza has "SYSTEM = "compat"" , changing it to "SYSTEM = "compat OR LDAP"" allows authentication of these users either through AIX or LDAP. Changing the default stanza to "SYSTEM = "LDAP"" enables these users to authenticate exclusively through LDAP. Those users who have a **SYSTEM** attribute value defined are not affected by the default stanza.

### *Multiple base DN support:*

Previous to AIX 5L Version 5.3 with the 5300-05 Technology Level, AIX supports only one base DN for an LDAP entity. For example, you can only specify a single user base DN in the **/etc/security/ldap/ldap.cfg** file.

In case of multiple subtrees, the **userbasedn** attribute must point to a common parent of the subtrees for all of the users to be visible to AIX. This requires that all subtrees are under the same suffix, since there is no common parent between suffixes.

AIX 5L Version 5.3 with the 5300-05 Technology Level and later supports multiple base DN's. Up to 10 base DN's for each entity can be specified in the **/etc/security/ldap/ldap.cfg** file. The base DN's are prioritized in the order they appear in the **/etc/security/ldap/ldap.cfg** file. An operation by AIX commands in case of multiple base DN's is done according to the base DN priority with the following behavior:

- A query operation (for example, by the **lsuser** command), is done to the base DN's according to their priority until a matching account is found, or failure is returned if all of the base DN's are searched without finding a match. Querying for ALL results in all of the accounts from every base DN being returned.
- A modification operation (for example, by the **chuser** command), is done to the first matching account.
- A delete operation (for example, by the **rmuser** command), is done to the first matching account.
- A creation operation (for example, the **mkuser** command), is done only to the first base DN. AIX does not support creating accounts to other base DN's.

It is the directory server administrator's responsibility to maintain a collision-free account database. If there are multiple definitions of the same account, each under a different subtree, only the first account is visible to AIX. An search operation returns only the first matching account. Similarly, a modification or a delete operation is done only to the first matching account.

The **mksecldap** command, when used to configure a LDAP client, will find the base DN for each entity and save it to the **/etc/security/ldap/ldap.cfg** file. When multiple base DN's are available on the LDAP server for a entity, the **mksecldap** command randomly uses any one of them. To have AIX work with multiple base DN's, you need to edit the **/etc/security/ldap/ldap.cfg** file after the **mksecldap** command has completed successfully. Find the appropriate base DN definition and add additional base DN's needed. AIX supports up to 10 base DN's for each entity, any additional base DN's are ignored.

AIX also supports user defined filter and search scope for each base DN. A base DN can have its own filter and scope that might be different from its peer base DN's. Filters can be used to define the set of accounts that are visible to AIX.

Only those accounts that satisfy the filter are visible to AIX.

*Setting up SSL on the LDAP server:*

In order to set up SSL on the LDAP server, install the **ldap.max\_crypto\_server** and **GSKit** file sets to enable server encryption support. These file sets can be found on the AIX expansion pack.

Follow these steps to enable SSL support for IBM Directory server authentication.

1. Install the IBM Directory **GSKit** package if it is not installed.
2. Generate the IBM Directory server private key and server certificate using the **gsk7ikm** utility (installed with **GSKit**). The server's certificate might be signed by a commercial Certification Authority (CA), such as VeriSign, or it might be self-signed with the **gsk7ikm** tool. The CA's public certificate (or the self-signed certificate) must also be distributed to the client application's key database file.
3. Store the server's key database file and associated password stash file on the server. The default path for the key database, **/usr/ldap/etc** directory, is a typical location.
4. For initial server setup, run the following command:

```
mksecldap -s -a cn=admin -p pwd -S rfc2307aix -k /usr/ldap/etc/mykey.kdb -w keypwd
```

Where **mykey.kdb** is the key database, and **keypwd** is the password to the key database. To set up a server that has already been configured and is running:

```
mksecldap -s -a cn=admin -p pwd -S rfc2307aix -u NONE -k /usr/ldap/etc/mykey.kdb -w keypwd
```

### Setting up SSL on the LDAP client:

To use SSL on an LDAP client, install the **ldap.max\_crypto\_client** and **GSKit** filesets off of the AIX expansion pack.

Follow these steps to enable SSL support for LDAP after the server has been enabled for SSL.

1. Run `gsk7ikm` to generate the key database on each client.
2. Copy the server certificate to each of the clients. If the server SSL uses a self-signed certificate, the certificate must be exported first.
3. On each client system, run `gsk7ikm` to import the server certificate to the key database.
4. Enable SSL for each client:

```
mksecldap -c -h servername -a adminDN -p pwd -k /usr/ldap/etc/mykey.kdb -p keypwd
```

Where **/usr/ldap/etc/mykey.kdb** is the full path to the key database and *keypwd* is the password to the key. If the key password is not entered from the command line, a stashed password file from the same directory is used. The stashed file needs to have the same name as the key database with an extension of **.sth** (for example, **mykey.sth**).

### LDAP host access control:

AIX provides user-level host access (login) control for a system. Administrators can configure LDAP users to log in to an AIX system by setting their **SYSTEM** attribute to LDAP.

The **SYSTEM** attribute is in the **/etc/security/user** file. The **chuser** command can be used to set its value, similar to the following:

```
chuser -R LDAP SYSTEM=LDAP registry=LDAP foo
```

**Note:** With this type of control, do not set the default **SYSTEM** attribute to LDAP, which allows all LDAP users to login to the system.

This sets the LDAP attribute to allow user *foo* to log in to this system. It also sets the registry to LDAP, which allows the login process to log *foo*'s login attempts to LDAP, and also allows any user management tasks done on LDAP.

The administrator needs to run such setup on each of the client systems to enable login by certain users.

Starting with AIX 5.2, AIX has implemented a feature to limit a LDAP user only to log in to certain LDAP client systems. This feature allows centralized host access control management. Administrators can specify two host access control lists for a user account: an allow list and a deny list. These two user attributes are stored in the LDAP server with the user account. A user is allowed access to systems or networks that are specified in the allow list, while he is denied access to systems or networks in the deny list. If a system is specified in both the allow list and the deny list, the user is denied access to the system. There are two ways to specify the access lists for a user: with the **mkuser** command when the user is created or with the **chuser** command for an existing user. For backward compatibility, if both the allow list and deny list do not exist for a user, the user is allowed to login to any LDAP client systems by default. Beginning in AIX 5.2, this host access control feature is available.

Examples of setting allow and deny permission lists for users are the following:

```
mkuser -R LDAP hostsallowedlogin=host1,host2 foo
```

This creates a user *foo*, and user *foo* is only allowed to log in to *host1* and *host2*.

```
mkuser -R LDAP hostsdeniedlogin=host2 foo
```

This create user *foo*, and user *foo* can log in to any LDAP client systems except *host2*.

```
chuser -R LDAP hostsallowedlogin=192.9.200.1 foo
```

This sets user *foo* with permission to log in to the client system at address 192.9.200.1.

```
chuser -R LDAP hostsallowedlogin=192.9.200/24 hostsdeniedlogin=192.9.200.1 foo
```

This sets user *foo* with permission to log in to any client system within the 192.9.200/24 subnet , except the client system at address 192.9.200.1.

For more information, see the **chuser** command.

### ***Secure communication with SSL:***

Depending on the authentication type being used between the LDAP client and server, passwords are sent in either crypted format (*unix\_auth*) or in clear text (*ldap\_auth*). Use Secure Socket Layer (SSL) to protect against security exposure when you send even encrypted passwords over the network, or, in some cases, the Internet. AIX provides packages for SSL that can provide secure communication between directory servers and clients.

For more information, see:

- “Setting up SSL on the LDAP server” on page 139
- “Setting up SSL on the LDAP client” on page 140

### ***Kerberos bind:***

In addition to a simple bind using a bind DN and a bind password, the **secdapclntd** daemon also supports a bind using Kerberos V credentials.

The keys of the bind principal are stored in a keytab file and need to be made available to the **secdapclntd** daemon in order to use Kerberos bind. With Kerberos bind enabled, the **secdapclntd** daemon does Kerberos authentication to the LDAP server using the principal name and keytab specified in the **/etc/security/ldap/ldap.cfg** client configuration file. Using Kerberos bind makes the **secdapclntd** daemon ignore the bind DN and the bind password specified in **/etc/security/ldap/ldap.cfg** file.

When Kerberos authentication is successful, the **secdapclntd** daemon saves the bind credentials to the **/etc/security/ldap/krb5cc\_secdapclntd** directory. The saved credentials are used for a later rebind. If credentials are more than one hour old at the time that the **secdapclntd** daemon tries to rebind to a LDAP server, the **secdapclntd** daemon will reinitialize to renew credentials.

To configure the LDAP client system to use Kerberos bind, you must configure the client using the **mksecdap** command using a bind DN and a bind password. If the configuration is successful, edit the **/etc/security/ldap/ldap.cfg** file with the correct values for Kerberos related attributes. The **secdapclntd** daemon uses the Kerberos bind at restart. After successful configuration, the bind DN and the bind password are not used any more. They can be safely removed or commented out of the **/etc/security/ldap/ldap.cfg** file.

#### *Creating a Kerberos principal:*

You need to create at least two principals on the Key Distribution Center (KDC) for use by the IDS server and client in order to support Kerberos bind. The first principal is the LDAP server principal and the second one is the principal used by client systems to bind to the server.

Each of the principal keys need to be placed in a keytab file so that they can be used to start the server process or the client daemon process.

The following example is based on the IBM Network Authentication Service. If you install Kerberos software from other sources, the actual commands may be different than what is shown here.

- Start the kadmin tool on the KDC server as the root user.

```
#/usr/krb5/sbin/kadmin.local
kadmin.local:
```

- Create the `ldap/serverhostname` principal for the LDAP server. The `serverhostname` is the fully qualified DNS host that will run the LDAP server.

```
kadmin.local: addprinc ldap/plankton.austin.ibm.com
WARNING: no policy specified for "ldap/plankton.austin.ibm.com@ud3a.austin.ibm.com":
Re-enter password for principal "ldap/plankton.austin.ibm.com@ud3a.austin.ibm.com":
Principal "ldap/plankton.austin.ibm.com@ud3a.austin.ibm.com" created.
kadmin.local:
```

- Create a keytab for the created server principal. This key will be used by the LDAP server during server startup. To create a keytab called **slapd\_krb5.keytab**:

```
kadmin.local: ktadd -k /etc/security/slapd_krb5.keytab ldap/plankton.austin.ibm.com
Entry for principal ldap/plankton.austin.ibm.com with kvno 2,
encryption type Triple DES cbc mode with HMAC/shal added to keytab
WRFIELD:/etc/security/slapd_krb5.keytab.
Entry for principal ldap/plankton.austin.ibm.com with kvno 2,
encryption type ArcFour with HMAC/md5 added to keytab WRFIELD:/etc/security/slapd_krb5.keytab.
Entry for principal ldap/plankton.austin.ibm.com with kvno 2,
encryption type AES-256 CTS mode with 96-bit SHA-1 HMAC added to keytab
WRFIELD:/etc/security/slapd_krb5.keytab.
Entry for principal ldap/plankton.austin.ibm.com with kvno 2,
encryption type DES cbc mode with RSA-MD5 added to keytab WRFIELD:/etc/security/slapd_krb5.keytab.
kadmin.local:
```

- Create a principal named `ldapadmin` for the IDS administrator.

```
kadmin.local: addprinc ldapadmin
WARNING: no policy specified for ldapadmin@ud3a.austin.ibm.com; defaulting to no policy.
Note that policy may be overridden by ACL restrictions.
Enter password for principal "ldapadmin@ud3a.austin.ibm.com":
Re-enter password for principal "ldapadmin@ud3a.austin.ibm.com":
Principal "ldapadmin@ud3a.austin.ibm.com" created.
kadmin.local:
```

- Create a keytab for the bind principal **kdapadmin.keytab**. This key can be used by the **secdapclntd** client daemon.

```
kadmin.local: ktadd -k /etc/security/ldapadmin.keytab ldapadmin
Entry for principal ldapadmin with kvno 2, encryption type
Triple DES cbc mode with HMCA/shal added to keytab WRFIELD:/etc/security/ldapadmin.keytab.
Entry for principal ldapadmin with kvno 2, encryption type
ArcFour with HMAC/md5 added to keytab WRFIELD:/etc/security/ldapadmin.keytab.
Entry for principal ldapadmin with kvno 2, encryption type
AES-256 CTS mode with 96-bit SHA-1 HMAC added to keytab WRFIELD:/etc/security/ldapadmin.keytab.
Entry for principal ldapadmin with kvno 2, encryption type
DES cbc mode with RSA-MD5 added to keytab WRFIELD:/etc/security/ldapadmin.keytab.
kadmin.local
```

- Create a principal named `ldaproxy` for clients to bind to the LDAP server.

```
kadmin.local: addprinc ldaproxy
WARNING: no policy specified for ldaproxy @ud3a.austin.ibm.com; defaulting to no policy.
Note that policy may be overridden by ACL restriction
Enter password for principal "ldaproxy@ud3a.austin.ibm.com":
Re-enter password for principal "ldaproxy@ud3a.austin.ibm.com":
Principal "ldaproxy@ud3a.austin.ibm.com" created.
kadmin.local:
```

- Create a keytab called **ldaproxy.keytab** for the bind principal **ldaproxy**. This key can be used by the **secdapclntd** client daemon.

```
kadmin.local: ktadd -k /etc/security/ldaproxy.keytab ldaproxy
Entry for principal ldaproxy with kvno 2, encryption type
Triple DES cbc mode with HMAC/sh1 added to keytab WRFIELD:/etc/security/ldaproxy.keytab.
Entry for principal ldaproxy with kvno 2, encryption type
ArcFour with HMAC/md5 added to keytab WRFIELD:/etc/security/ldaproxy.keytab
Entry for principal ldaproxy with kvno 2, encryption type
```

```
AES-256 CTS mode with 96-bit SHA-1 HMAC added to keytab WRFILE:/etc/security/ldapproxy.keytab
Entry for principal ldapproxy with kvno 2,
encryption type DES cbc mode with RSA-MD5 added to keytab WRFILE:/etc/security/ldapproxy.keytab.
kadmin.local:
```

### *Enabling the IDS server Kerberos bind:*

The following procedure enables the IDS server for Kerberos bind.

The following example shows how to configure an IDS server for Kerberos bind.

This example was tested using IDS v5.1:

1. Install the **krb5.client** fileset.
2. Make sure the **/etc/krb5/krb5.conf** file exists and is configured properly. If you need to configure it, you can run the **/usr/sbin/config.krb5** command.

```
config.krb5 -r ud3a.austin.ibm.com -d austin.ibm.com -c KDC -s alyssa.austin.ibm.com
Initializing configuration...
Creating /etc/krb5/krb5_cfg_type...
Creating /etc/krb5/krb5.conf...
The command completed successfully.
cat /etc/krb5/krb5.conf
[libdefaults]
 default_realm = ud3a.austin.ibm.com
 default_keytab_name = FILE:/etc/krb5/krb5.keytab
 default_tkt_enctypes = des3-cbc-sha1 arcfour-hmac aes256-cts des-cbc-md5 des-cbc-crc
 default_tgs_enctypes = des3-cbc-sha1 arcfour-hmac aes256-cts des-cbc-md5 des-cbc-crc
[realms]
 ud3a.austin.ibm.com = {
 kdc = alyssa.austin.ibm.com:88
 admin_server = alyssa.austin.ibm.com:749
 default_domain = austin.ibm.com
 }
[domain_realm]
 .austin.ibm.com = ud3a.austin.ibm.com
 alyssa.austin.ibm.com = ud3a.austin.ibm.com
[logging]
 kdc = FILE:/var/krb5/log/krb5
 admin_server = FILE:/var/krb5/log/kadmin.log
 default = FILE:/var/krb5/log/krb5lib.log
```

3. Get the keytab file of the `ldap:/serverhostname` principal, and place it in the **/usr/ldap/etc** directory. For example: **/usr/ldap/etc/slaped\_krb5.keytab**.
4. Set the permission to allow the server process to access the file.

```
chown ldap:ldap/usr/ldap/etc/slaped_krb5.keytab
#
```

5. To enable the IDS server for Kerberos bind, edit the **/etc/ibmslapd.conf** file and append the following entry:

```
dn: cn=Kerberos, cn=Configuration
cn: Kerberos
ibm-slapdKrbAdminDN: ldapadmin
ibm-slapdKrbEnable: true
ibm-slapdKrbIdentityMap: true
ibm-slapdKrbKeyTab: /usr/ldap/etc/slaped_krb5.keytab
ibm-slapdKrbRealm: ud3a.austin.ibm.com
objectclass: ibm-slapdKerberos
objectclass: ibm-slapdconfigEntry
objectclass: top
```

6. Map the `ldapproxy` principal to a bind DN named `cn-proxyuser,cn=aixdata`.

- a. If the bind DN entry exists in the IDS server, create a file named **ldaproxy.ldif** with the following content:

```
dn: cn=proxyuser,cn=aixdata
changetype: modify
add: objectclass
objectclass: ibm-securityidentities
-
add:altsecurityidentities
alsecurityidentities: Kerberos:ldaproxy@ud3a.austin.ibm.com
```

OR

- b. If the bind DN entry is not yet added to the server, create a file named **proxyuser.ldif** with the following content:

**Note:** You will need to replace *proxyuserpwd* with your password.

```
dn: cn=proxyuser,cn=mytest
cn: proxyuser
sn: proxyuser
userpassword: proxyuserpwd
objectclass: person
objectclass: top
objectclass: ibm-securityidentities
altsecurityidentities: Kerberos:ldaproxy@ud3a.austin.ibm.com
```

Add the bind DN entry that is created to the IDS server using the **ldapmodify** command.

```
ldapmodify -D cn-admin -w adminPwd -f /tmp/proxyuser.ldif modifying entry cn=proxyuser,cn=mytest
#
```

7. Restart the IDS server.

*Enabling the AIX LDAP client Kerberos bind:*

You can configure an AIX LDAP client system to use Kerberos in its initial bind to an LDAP server.

The IDS server must be configured in this manner for the server host to be a client to itself.

This example was tested using IDS v 5.1:

1. Install the **krb5.client** fileset.
2. Make sure the **/etc/krb.conf** file exists and is configured properly. If it is not properly configured, you can run the **/usr/sbin/config.krb5** command to configure it.
3. Get the keytab file of the bind principal, and place it in the **/etc/security/ldap** directory.
4. Set the permission to 600.
5. Configure the client using the **mksecldap** command using the bind DN and the bind password. Make sure that AIX commands work on LDAP users.
6. Edit the **/etc/security/ldap/ldap.cfg** file to set the Kerberos related attributes. In the following example, the bind principal is **ldaproxy** and the keytab file is **ldaproxy.keytab**. If you want IDS server administrator privileges, replace the *ldaproxy* with *ldapadmin* and replace the *ldaproxy.keytab* with *ldapadmin.keytab*.

```
useKRB5:yes
krbprincipal:ldaproxy
krbkeypath:/etc/security/ldap/ldaproxy.keytab
krbcmddir:/usr/krb5/bin/
```

Now the bind DN and bind password can be removed or commented out of the **ldap.cfg** file because the **secldapclntd** daemon now uses Kerberos bind.

7. Restart the **secldapclntd** daemon.
8. The **/etc/security/ldap/ldap.cfg** file can now be propagated to other client systems.



### ***LDAP security information server auditing:***

SecureWay Directory version 3.2 (and later) provides a default server audit logging function. Once enabled, this default audit plugin logs LDAP server activities to a log file. See the LDAP documentation in *Packaging Guide for LPP Installation* for more information on this default audit plugin.

An LDAP security information server auditing function has been implemented in AIX 5.1 and later, called the *LDAP security audit plugin*. It is independent of the SecureWay Directory default auditing service, so that either one or both of these auditing subsystems can be enabled. The AIX audit plugin records only those events that update or query the AIX security information on an LDAP server. It works within the framework of AIX system auditing.

To accommodate LDAP, the following audit events are contained in the **/etc/security/audit/event** file:

- LDAP\_Bind
- LDAP\_Unbind
- LDAP\_Add
- LDAP\_Delete
- LDAP\_Modify
- LDAP\_Modifydn
- LDAP\_Search

An `ldapserv` audit class definition is also created in the **/etc/security/audit/config** file that contains all of the above events.

To audit the LDAP security information server, add the following line to each user's stanza in the **/etc/security/audit/config** file:

```
ldap = ldapserv
```

Because the LDAP security information server audit plug-in is implemented within the frame of the AIX system auditing, it is part of the AIX system auditing subsystem. Enable or disable the LDAP security information server audit using system audit commands, such as **audit start** or **audit shutdown**. All audit records are added to the system audit trails, which can be reviewed with the **auditpr** command. For more information, see "Auditing overview" on page 119.

### ***LDAP commands:***

There are several LDAP commands.

#### **lsldap command**

The **lsldap** command can be used to display naming service entities from the configured LDAP server. These entities are aliases, automount, bootparams, ethers, groups, hosts, netgroups, networks, passwd, protocols, rpc and services.

#### **mksecldap command**

The **mksecldap** command can be used to set up IBM SecureWay Directory servers and clients for security authentication and data management. This command must be run on the server and all clients.

#### **secldapclntd daemon**

The **secldapclntd** daemon accepts requests from the LDAP load module, forwards the request to the LDAP Security Information Server, and passes the result from the server back to the LDAP load module.

For more information on the LDAP attribute mapping file format, see **LDAP attribute mapping file format** in the *AIX Version 6.1 Files Reference*.

## Related information

The **mksecdap**, **start-secdapclntd**, **stop-secdapclntd**, **restart-secdapclntd**, **ls-secdapclntd**, **sectoldif**, and **flush-secdapclntd** commands.

The **secdapclntd** daemon.

The **/etc/security/ldap/ldap.cfg** file.

The LDAP attribute mapping file format.

Migration to LDAP from NIS, including the netgroup setting can be found in the Network Information Services (NIS and NIS+) Guide: Appendix B. Migrating from NIS and NIS+ to RFC 2307-compliant LDAP services.

*LDAP management commands:*

Several commands are used for LDAP management.

### **start-secdapclntd** command

The **start-secdapclntd** command starts the **secdapclntd** daemon if it is not running.

### **stop-secdapclntd** command

The **stop-secdapclntd** command terminates the running **secdapclntd** daemon process.

### **restart-secdapclntd** command

The **restart-secdapclntd** script stops the **secdapclntd** daemon if it is running, and then restarts it. If the **secdapclntd** daemon is not running, it simply starts it.

### **ls-secdapclntd** command

The **ls-secdapclntd** command lists the **secdapclntd** daemon status.

### **flush-secdapclntd** command

The **flush-secdapclntd** command clears the cache for the **secdapclntd** daemon process.

### **sectoldif** command

The **sectoldif** command reads users and groups defined locally, and prints the result to standard output in **ldif** format.

*ldap.cfg file format:*

The **/etc/security/ldap/ldap.cfg** file contains information for the **secdapclntd** daemon to start and function properly as well as information for fine tuning the daemon's performance.

Before AIX 5L Version 5.3 with the 5300-05 Technology Level, AIX supports only one base DN for each entity. For example, only one **userbasedn** can be specified for the user entity. For AIX 5L Version 5.3 with

the 5300-05 Technology Level and later, the **secdapclntd** daemon supports multiple base DN's (up to 10 base DN's can be specified for each entity). The following example shows two base DN's for the user entity:

```
userbasedn: ou=people, ou=dept1, cn=aixdata
userbasedn: ou=people, ou=dept2, cn=aixdata
```

With multiple base DN's, search operations are done in the order of the base DN's specified until a matching account is found. The search fails only if no match is found from all of the base DN's. A search of ALL accounts (for example, **lsuser -R LDAP ALL**), results in all base DN being searched and all user accounts returned. Modification operations and delete operations are done to the first matching account found from the base DN's. An account creation operation by AIX commands is only be created to the first base DN.

AIX 5L Version 5.3 with the 5300-05 Technology Level and later also supports extended base DN format for associating a customized filter and scope with each base DN. The following base DN formats are supported:

1. **userbasedn: ou=people, cn=aixdata**
2. **userbasedn: ou=people, cn=aixdata?scope**
3. **userbasedn: ou=people, cn=aixdata??filter**
4. **userbasedn: ou=people, cn=aixdata?scope?filter**

The first format represents the default format used by the **secdapclntd** daemon. The second and third formats allow limiting of a search by using a scope attribute or a filter attribute respectively. The fourth format allows both a scope and a filter.

The scope attribute accepts the following values:

- **sub**
- **one**
- **base**

If the scope field is not specified, it defaults to **sub**.

The filter attribute allows further limiting the entries defined in the LDAP server. You can use this filter to make only users with certain properties visible to the system. The following shows a few valid filter formats, where attribute is the name of a LDAP attribute, and value specifies the search criteria. The value can be a wild card **"\*\*"**.

- **(attribute=value)**
- **(&(attribute=value)(attribute=value))**
- **(!(attribute=value)(attribute=value))**

The **/etc/security/ldap/ldap.cfg** file is updated by the **mksecdap** command at client setup.

For more information on the **/etc/security/ldap/ldap.cfg** file, see **/etc/security/ldap/ldap.cfg** in the *AIX Version 6.1 Files Reference*.

*Mapping file format for LDAP attributes:*

These map files are used by the **/usr/lib/security/LDAP** module and the **secdapclntd** daemon for translation between AIX attribute names to LDAP attribute names.

Each entry in a mapping file represents a translation for an attribute. An entry has four space-separated fields:

```
AIX_Attribute_Name AIX_Attribute_Type LDAP_Attribute_Name LDAP_Value_Type
```

|                            |                                                                                                   |
|----------------------------|---------------------------------------------------------------------------------------------------|
| <b>AIX_Attribute_Name</b>  | Specifies the AIX attribute name.                                                                 |
| <b>AIX_Attribute_Type</b>  | Specifies the AIX attribute type. Values are SEC_CHAR, SEC_INT, SEC_LIST, and SEC_BOOL.           |
| <b>LDAP_Attribute_Name</b> | Specifies the LDAP attribute name.                                                                |
| <b>LDAP_Value_Type</b>     | Specifies the LDAP value type. Values are <b>s</b> for single value and <b>m</b> for multi-value. |

## EFS Encrypted File System

The Encrypted Files System enables individual users on the system to encrypt their data on J2 file system through their individual key stores.

A key is associated to each user. These keys are stored in cryptographically protected key store and upon successful login, the user's keys are loaded into the kernel and associated with the processes credentials. Later on, when the process needs to open an EFS-protected file, these credentials are tested and if a key matching the file protection is found, the process is able to decrypt the file key and therefore the file content. Group based key management are supported too.

**Note:** EFS is part of an overall security strategy. It is designed to work in conjunction with sound computer security practices and controls.

### Encrypted File System usability

Encrypted File System (EFS) key management, file encryption, and file decryption are transparent to users in normal operations.

EFS is part of base AIX OS. To enable EFS, root (or any user with the RBAC **aix.security.efs** authorization, see EFS actors for more information) must use the **efsenable** command to activate EFS and create the EFS environment. This is a one time system enablement. After EFS is enabled, when the user logs in, its key and keystore are silently created and protected or encrypted with the user login password. The users keys are then used silently by the J2 file system when encrypting or decrypting EFS files. Every EFS file is protected with its own unique file key, and this file key is in turn protected or encrypted with the file owner or group key depending on the file permissions.

By default, a J2 File System is not EFS-enabled. When it is EFS-enabled, the J2 File System transparently manages encryption and decryption in the kernel for read and write requests. Users and groups administration commands (such as **mkgroup**, **chuser**, and **chgroup**) transparently manage the users' and groups' keystores.

The following EFS commands are provided to allow users to manage their keys and file encryption:

#### **efskeymgr**

Manages and administers the keys

#### **efsmgr**

Manages the encryption of files/directories/file system

### Encrypted File System actors

There are three types of users who can manage and use EFS keys:

#### **Full or restricted access as root:**

The root access to the keys can be unlimited or limited. In either mode, it is not possible for root to simply **su** to a user and gain access to the user's encrypted file or keystore.

In one mode, root can reset the user's keystore password, and might gain access to the user's keys within this keystore. This mode provides greater system administration flexibility.

In the other mode, root can reset the user's logon password, cannot reset the user's keystore password. It is not possible for root to substitute user (with the **su** command) and inherit an open keystore. While root can create and delete users and groups, along with their associated keystores, cannot gain access to the keys within these keystores. This mode provides a greater degree of protection against an attack from malicious root.

There are two modes for managing and using keystores, Root Admin and Root Guard. An EFS administration key is also provided.

The EFS administration key enables access to reset the password to all keystores in Root Admin mode. This key is located in the **efs\_admin** special keystore. Access to the **efs\_admin** special keystore is granted only to authorized users (root user and security group at installation, or the RBAC **aix.security.efs** authorization).

When a keystore is in Root Guard mode, the keys contained in this keystore cannot be retrieved without the correct keystore password. This provides strong security against a malicious root, but can also cause problems if a user forgets their password, as there is no way to regenerate the password without losing the keys in the keystore, and the user can no longer access their data as a result. In this keystore mode, some operations cannot be treated immediately and are scheduled as pending operations. These pending operations are generated in cases such as adding or suppressing a group access key in a user keystore or regenerating a private key. These are managed by the keystore owner.

*efs\_admin administration key:*

The **efs\_admin** keystore contains a special key which can open any user or group keystore in root admin mode (the default mode).

The password to open this special keystore is stored in root user and security group keystores when EFS is activated. This password can be given to other groups and users or removed with the **efskeymgr** command. This key, in conjunction with the RBAC **aix.security.efs** authorization, allows an user to administrate EFS (that is, access keystores in root admin mode).

### **efs\_admin RBAC considerations**

On systems with Role Based Access Control enabled, the **efs\_admin** command is protected with the **aix.security.efs** authorization.

### ***User keystore:***

The user keystore is managed automatically for most common operations. The **efskeymgr** command is used for maintenance tasks and advanced EFS use. Users can create encrypted files and directories with the **efsmgr** command. Key store management is integrated into most user admin commands. If a user is added to a group, then the user will automatically have access to the group keystore.

A file owner with EFS access to the file use the **efsmgr** command to grant EFS access to other users and groups (similar to the control that file owners have with ACLs in UNIX). Users can change their passwords without effecting separate processes running under the same UID with an open keystore.

### **Encrypted File System keystore**

Keystores are protected with a password. Users can choose an alternate keystore password other than their login password. In this case, the keystore is not opened and available during the user's standard login. Instead, the user must manually load the keystore by using the **efskey** command to provide the keystore password.

The keystore format is **PKCS # 12**. The keystores are stored in the following files:

**user keystore**

/var/efs/users//keystore

**group keystore**

/var/efs/groups//keystore

**efsadmin keystore**

/var/efs/efs\_admin/keystore

If a user sets their logon password and their keystore password to the same password, their keystore is opened and enabled when they log in.

A user can use the EFS **efskeymgr** command to select the type of encryption algorithm and the key length.

Access to the keystore is inherited by any child process.

Group- based key management is also supported. Only group members can add or remove group keys to member's keystores if the group keystore is in guard mode. A user keystore contains the user's private key and also the password to open the user's groups keystores, which contain the group's private keys.

**Note:** The EFS keystore is opened automatically as part of the standard AIX login only when the user's keystore password matches their login password. This is set up by default during the initial creation of the user's keystore. Login methods other than the standard AIX login, such as loadable authentication modules and pluggable authentication modules may not automatically open the keystore.

**Encryption and inheritance**

EFS is a feature of J2. The filesystem's **efs** option must be set to **yes** (see the **mkfs** and **chfs** commands).

J2 EFS automatically encrypts and decrypts user data. However, if a user has read access to an EFS-activated file but does not have the right key, then the user cannot read the file in the normal manner; if the user does not have a valid key, it is impossible to decrypt the data.

All cryptographic functions come from the CLiC kernel services and CLiC user libraries.

By default, a J2 File System is not EFS-enabled. A J2 File System must be EFS-enabled before File System EFS inheritance can be activated or any EFS encryption of user data can take place. A file is created as an encrypted file either explicitly with the **efsmgr** command or implicitly via EFS inheritance. EFS inheritance can be activated either at the File System level, at a Directory level, or both.

The **ls** command lists entries of an encrypted file with a preceding **e**.

The **cp** and **mv** commands can handle metadata and encrypted data seamlessly across EFS-to-EFS and EFS-to-non-EFS scenarios.

The **backup**, **restore**, and **tar** commands and related commands can back up and restore encrypted data, including EFS meta-data used for encryption and decryption.

**Backup and restore**

It is important to properly manage the archiving or backup of the keystores associated with the archived EFS files. You must also manage and maintain the keystore passwords associated with the archived or backup keystores. Failure to do either of these tasks may result in data loss.

When backing up EFS encrypted files, it is possible to use the **-Z** option with the **backup** command to back up the encrypted form of the file, along with the file's cryptographic meta-data. Both the file data and

meta-data are protected with strong encryption. This has the security advantage of protecting the backed-up file through strong encryption. It is necessary to back up the keystore of the file owner and group associated with the file that is being backed up. These key stores are located in the following files:

**users keystores**

`/var/efs/users/user_login/*`

**group keystore**

`/var/efs/groups//keystore`

**efsadmin keystore**

`/var/efs/efs_admin/keystore`

To restore an EFS backup (made with the **backup -Z**), the **restore** command's **-Z** option must be used to restore the data. The **restore** command's **-Z** option ensures that the file's necessary crypto-meta data is also restored. During the restore process, it is not necessary to restore the backed-up keystores if the user has not changed the keys in their individual keystore. When a user changes their password to open their keystore, it does not change their keystore's internal key. The keystore's internal keys are changed with the **efskeymgr** command.

If the user's internal, keystore key remains the same, the user can immediately open and decrypt the restored file using their current keystore. However, if the key internal to the user's keystore has changed, the user must open the keystore that was backed up in association with the backed-up file. This keystore can be opened with the **efskeymgr -o** command. The **efskeymgr** command prompts the user for a password to open the keystore. This password is the one used in association with the keystore at time of the backup.

For example, assume that the user Bob's keystore was protected with the password **foo** (the password 'foo' is not a secure password and only used in this example for simplicities sake) and a backup of Bob's encrypted files was performed in January along with Bob's keystore. In this example, Bob also uses **foo** for his AIX login password. In February, Bob changed his password to **bar**, which also had the effect of changing his keystore access password to **bar**. If, in March, Bob's EFS files were restored, then Bob would be able to open and view these files with his current key store and password, because he did not change the keystore's internal key.

If however, it was necessary to change Bob's keystore's internal key (with the **efskeymgr** command), then by default the old keystore internal key is deprecated and left in Bob's keystore. When the user accesses the file, EFS will automatically recognize that the restored file used the old internal key, and EFS will then use the deprecated key to decrypt it. During this same access instance, EFS will convert the file over to using the new internal key. There is not a significant performance impact in the process, because it is all handled via the key store and file's crypto meta-data, and does not require that the file data is re-encrypted.

If the deprecated internal key is removed through **efskeymgr**, then the old keystore containing the old internal key must be restored and used in conjunction with the files encrypted with this internal key.

This raises the question of how to securely maintain and archive old passwords. There are methods and tools to archive passwords. Generally, these methods involve having a file which contains a list of all old passwords, and then encrypting this file and protecting it with the current keystore, which in turn is protected by the current passwords. However, IT environments and security policies vary from organization to organization, and consideration and thought should be given to the specific security needs of your organization to develop security policy and practices that are best suited to your environment.

## J2 EFS internal mechanism

Each J2 EFS-activated file is associated with a special extended attribute which contains EFS meta-data used to validate crypto authority and information used to encrypt and decrypt files (keys, crypto algorithm, etc).

The EA content is opaque for J2. Both user credentials and EFS meta-data are required to determine a crypto authority (access control) for any given EFS-activated file.

**Note:** Special attention should be given to situations where a file or data may be lost (for example, removal of the file's EA).

### EFS Protection Inheritance

After a directory is EFS-activated, any newly created immediate children are automatically EFS-activated if not manually overridden.

The scope of a directory's inheritance is exactly one level. Any newly created child also inherits its parent's EFS attributes if its parent's directory is EFS-activated. Existing children maintain their current encrypted or non-encrypted state. The logical inheritance chain is broken if the parent changes its EFS attributes. These changes do not propagate down to the directory's existing children. Enabling encryption for a directory is a non-recursive operation (that is, it does not effect it's grandchildren). The parent directory's EFS attributes takes precedence over the filesystem's EFS attributes.

### Workload Partition considerations

Before enabling or using Encrypted File System within a Workload Partition, EFS must first be enabled on the global system with the **efsenable** command. This enablement only needs to be performed once. Additionally, all filesystems, including EFS-enabled filesystems, must be created from the global system.

### Setting up the Encrypted File System

You need to do this first.

The stage needs to be set just so.

1. Install the **clic.rte** fileset. This fileset contains the cryptographic libraries and kernel extension required by EFS. The **clic.rte** fileset can be found on the AIX Expansion Pack.
2. Enable EFS on the system with the **efsenable** command (for example `>efsenable -a`). When prompted for a password, it is reasonable to use the root password. Users keystores are created automatically, then the user logs in, or re-logs in, after the **efsenable** command has been run. Once **efsenable -a** has been run on a system, then the system is EFS-enabled and the **efsenable** command does not need to be run again.
3. Create an EFS-enabled filesystem with the **-a efs=yes** option. For example, `crfs -v jfs2 -m /foo -A yes -a efs=yes -g rootvg -a size=20000`
4. After mounting the filesystem, turn on the cryptographic inheritance on the EFS-enabled filesystem. This can be done with the **efsmgr** command. To continue the previous example where the filesystem **/foo** was created, run the following command: `efsmgr -s -E /foo`. This allows every file created and used in this filesystem to be an encrypted file.

From this point forward, when a user or process with an open keystore creates a file on this filesystem, the file will be encrypted. When the user or file reads the file, the file is automatically decrypted for users who are authorized to access the file.

See the following for more information:

- **chfs, chgroup, chuser, cp, efsenable, efskeymgr, efsmgr, lsuser, ls, mkgroup, mkuser, and mv** commands
- **/etc/security/group** and **/etc/security/user** files

### Public Key Cryptography Standards #11

The Public Key Cryptography Standards #11 (PKCS #11) subsystem provides applications with a method for accessing hardware devices (tokens) regardless of the type of device.



The content in this section conforms to Version 2.01 of the PKCS #11 standard.

The PKCS #11 subsystem has been implemented using the following components:

- A slot manager daemon (**pkcsslotd**), which provides the subsystem with information regarding the state of available hardware devices. This daemon is started automatically during installation and when the system is rebooted.
- An API shared object (**/usr/lib/pkcs11/pkcs11\_API.so**) is provided as a generic interface to the adapters for which PKCS #11 support has been implemented.
- An adapter-specific library, which provides the PKCS #11 support for the adapter. This tiered design allows the user to use new PKCS #11 devices when they come available without recompiling existing applications.

## **IBM 4758 Model 2 Cryptographic Coprocessor**

The IBM 4758 Model 2 Cryptographic Coprocessor provides a secure computing environment.

Before attempting to configure the PKCS #11 subsystem, verify that the adapter has been properly configured with a supported microcode.

## **IBM 4960 Cryptographic Accelerator**

The IBM 4960 Cryptographic Accelerator provides a means of offloading cryptographic transactions. Before attempting to configure the PKCS #11 subsystem, verify that the adapter has been properly configured.

### ***Verifying the IBM 4758 Model 2 Cryptographic Coprocessor for use with the Public Key Cryptography Standards #11 subsystem:***

The PKCS #11 subsystem is designed to automatically detect adapters capable of supporting PKCS #11 calls during installation and at reboot. For this reason, any IBM 4758 Model 2 Cryptographic Coprocessor that is not properly configured will not be accessible from the PKCS #11 interface and calls sent to the adapter will fail.

To verify that your adapter is set up correctly, complete the following:

1. Ensure that the software for the adapter is properly installed by typing the following command:

```
lsdev -Cc adapter | grep crypt
```

If the IBM 4758 Model 2 Cryptographic Coprocessor is not included in the resulting list, check that the card is seated properly and that the supporting software is correctly installed.

2. Determine that the proper firmware has been loaded onto the card by typing the following:

```
csufc1u /tmp/1 ST device_number_minor
```

Verify that the Segment 3 Image has the PKCS #11 application loaded. If it is not loaded refer to the adapter specific documentation to obtain the latest microcode and installation instructions.

**Note:** If this utility is not available, then the supporting software has not been installed.

### ***Verifying the IBM 4960 Model 2 Cryptographic Accelerator for use with the Public Key Cryptography Standards #11 subsystem:***

The PKCS #11 subsystem is designed to automatically detect adapters capable of supporting PKCS #11 calls during installation and at reboot. For this reason, any IBM 4960 Cryptographic Accelerator that is not properly configured will not be accessible from the PKCS #11 interface and calls sent to the adapter will fail.

To ensure that the software for the adapter is properly installed, type the following command:

```
lsdev -Cc adapter | grep ica
```

If the IBM 4960 Cryptographic Accelerator is not included in the resulting list, check that the card is seated properly and that the supporting device driver is correctly installed.

## **Public Key Cryptography Standards #11 subsystem configuration**

The PKCS #11 subsystem automatically detects devices supporting PKCS #11. However, in order for some applications to use these devices, some initial set up is necessary.

These tasks can be performed through the API (by writing a PKCS #11 application) or by using the SMIT interface. The PKCS #11 SMIT options are accessed either through **Manage the PKCS11 subsystem** from the main SMIT menu, or by using the **smit pkcs11** fast path.

### ***Initializing the token:***

Each adapter or PKCS #11 token must be initialized before it can be used successfully.

This initialization procedure involves setting a unique label to the token. This label allows applications to uniquely identify the token. Therefore, the labels should not be repeated. However; the API does not verify that labels are not re-used. This initialization can be done through a PKCS #11 application or by the system administrator using SMIT. If your token has a Security Officer PIN, the default value is set to 87654321. To ensure the security of the PKCS #11 subsystem, this value should be changed after initialization.

To initialize the token:

1. Enter the token management screen by typing `smit pkcs11`.
2. Select **Initialize a Token**.
3. Select a PKCS #11 adapter from the list of supported adapters.
4. Confirm your selection by pressing Enter.

**Note:** This will erase all information on the token.

5. Enter the Security Officer PIN (SO PIN) and a unique token label.

If the correct PIN is entered, the adapter will be initialized or reinitialized after the command has finished running.

### ***Setting the security officer PIN:***

Follow these steps to change an SO PIN from its default value.

To change the PIN from its default value:

1. Type `smit pkcs11`.
2. Select **Set the Security Officer PIN**.
3. Select the initialized adapter for which you want to set the PIN.
4. Enter the current PIN and a new PIN.
5. Verify the new PIN.

### ***Initializing the user PIN:***

After the token has been initialized, it might be necessary to set the user PIN to allow applications to access token objects.

Refer to your device specific documentation to determine if the device requires a user to log in before accessing objects.

To initialize the user PIN:

1. Enter the token management screen typing `smit pkcs11`.
2. Select **Initialize the User PIN**.
3. Select a PKCS #11 adapter from the list of supported adapters.
4. Enter the SO PIN and the User PIN.
5. Verify the User PIN.
6. Upon verification, the User PIN must be changed.

*Resetting the user PIN:*

To reset the user PIN, you can either reinitialize the PIN using the SO PIN or set the user PIN by using the existing user PIN.

To reset the PIN:

1. Enter the token management screen by typing `smit pkcs11`.
2. Select **Set the User PIN**.
3. Select the initialized adapter for which you want to set the user PIN.
4. Enter the current user PIN and a new PIN.
5. Verify the new user PIN.

## Public Key Cryptography Standards #11 usage

For an application to use the PKCS #11 subsystem, the subsystem's slot manager daemon must be running and the application must load in the API's shared object.

The slot manager is normally started at boot time by **inittab** calling the **/etc/rc.pkcs11** script. This script verifies the adapters in the system before starting the slot manager daemon. As a result, the slot manager daemon is not available before the user logs on to the system. After the daemon starts, the subsystem incorporates any changes to the number and types of supported adapters without intervention from the systems administrator.

The API can be loaded either by linking in the object at runtime or by using deferred symbol resolution. For example, an application can get the PKCS #11 function list in the following manner:

```
d CK_RV (*pf_init)();
void *d;
CK_FUNCTION_LIST *functs;

d = dlopen(e, RTLD_NOW);
if (d == NULL) {
 return FALSE;
}

pfoo = (CK_RV (*)())dlsym(d, "C_GetFunctionList");
if (pfoo == NULL) {
 return FALSE;
}

rc = pf_init(&functs);
```

## X.509 Certificate Authentication Service and Public Key Infrastructure

Certificate Authentication Service provides the AIX operating system with the ability to authenticate users using X.509 Public Key Infrastructure (PKI) certificates and to associate certificates with processes as proof of a user's identity. It provides this capability through the Loadable Authentication Module Framework (LAMF), the same extensible AIX mechanism used to provide DCE, Kerberos, and other authentication mechanisms.

## Overview of Certificate Authentication Service

Every user account participating in PKI authentication has a unique PKI certificate. The certificate in conjunction with a password is used to authenticate the user during login.

PKI certificates are based on public key/private key technology. This technology uses two asymmetric keys to encrypt and decrypt data. Data encrypted using one key can only be decrypted using the other key. A user keeps one key private, called the private key, storing it in a private keystore while publishing the other key, called the public key, in the form of a certificate. Certificates are commonly maintained on a Lightweight Directory Access Protocol (LDAP) server, either within an organization for intra-company usage or on the Internet for world-wide usage.

For a user named John to send a user named Kathy data that only she can decrypt, John would obtain the public key from Kathy's published certificate, encrypt the data using Kathy's public key, and send the data to her. Kathy would decrypt the data from John using her private key located in her private keystore.

This technology is also used for digital signatures. If Kathy wants to send data to John that is digitally signed by her, Kathy would use her private key to digitally sign the data and send the data and digital signature to John. John would obtain the public key from Kathy's published certificate and use the public key to verify the digital signature before using the data.

In both cases, Kathy's private key is maintained in a private keystore. The many types of private keystores include smart cards and files, but all keystore types protect private keys through the use of passwords or Personal Identification Numbers (PINs). They typically provide storage for multiple private keys along with certificates and other PKI objects. Users typically have their own keystores.

Certificate authentication service uses digital-signature technology to authenticate a user during login. Certificate authentication service locates the user's certificate and keystore based off the user's account name, obtains the certificate's matching private key from the user's keystore using the user's password, signs a data item with the user's private key, and checks the signature using the user's public key from the certificate. After the user authenticates, the system stores the user's certificate in protected memory, associating the certificate with every process created by the user. This in-memory association enables quick access to the user's certificate for any process owned by the user, as well as by the operating system's kernel.

### **Certificates:**

Understanding certificate authentication service requires a basic understanding of certificates, certificate formats, and certificate lifecycle management.

Certificates are standardized objects that follow the X.509 standard, of which version 3 (X.509v3) is the latest version. Certificates are created, signed, and issued by a Certificate Authority (CA) which is most commonly a software application that accepts and processes certificate requests. Certificates are comprised of several certificate attributes. Some of the attributes are required, but many are optional. Certificate attributes commonly used and discussed in this document are:

- Certificate Version - The X.509 version number (that is, 1, 2, or 3).
- Serial Number - A certificate serial number that uniquely distinguishes the certificate from all other certificates issued by the same CA.
- Issuer Name - A name specifying the certificate's issuing CA.
- Validity Period - The activation and expiration date of the certificate.
- Public Key - The public key.
- Subject Distinguished Name - A name specifying the certificate's owner.
- Subject Alternate Name Email - The owner's email address.
- Subject Alternate Name URI - The owner's Web site URI/URL.

Each certificate has a unique version number that indicates with which version of the X.509 standard it conforms. Each certificate has a serial number which uniquely distinguishes it from all other certificates issued by the same CA. The serial number is unique only to the issuing CA. The certificate's issuer name identifies the issuing CA.

Certificates are valid only between two specified dates: the "Not Before" date and the "Not After" date. Therefore, certificates may be created prior to their validity date and expire at some date in the future. It is common for certificates to have a life span of 3 months to 5 years.

The subject distinguished name specifies the certificate owner by using a specialized naming format known as a Distinguished Name (DN). A DN allows for the specification of the country, organization, city, state, owner name, and other attributes associated with the requesting entity (usually a person, but not limited to a person). The subject alternate name email allows for the specification of the owner's email address and the subject alternate name URI allows for the specification of the owner's Web site URI/URL.

### **Certificate authorities and certificates**

Certificate Authorities (CA) issue, store, and typically publish certificates. A common place to publish certificates is on an LDAP server, because LDAP allows for easy access to community oriented data. Certificate Authorities also handle the revocation of certificates and the management of certificate revocation lists (CRLs). Revoking a certificate is the act of publishing the fact that a specific certificate is no longer valid due to reasons other than the expiration of the certificate's validity period. Because copies of certificates can be maintained and used outside the control of the issuing CA, CAs publish a list of revoked certificates in a CRL so that outside entities may query the list. This places the responsibility on entities using a copied certificate to compare the copied certificate against the issuing CA's CRL. A CA may only revoke certificates that it creates or issues. It cannot revoke certificates issued by other CAs.

Administrative reasons for revoking a certificate include:

- Compromise of the certificate's private key.
- Certificate owner left the company.
- Compromise of the CA.

CAs also have their own identifying certificate. This allows CAs to identify each other in peer-to-peer communications among other uses (for example, chains of trust).

Many CAs support the Certificate Management Protocol (CMP) for requesting and revoking certificates. The protocol supports multiple methods to establish a secure connection between a client (also known as an End Entity) and the CA, though not all clients and CAs support all methods. One common method requires each certificate creation and revocation request to use a reference number and password recognized by the CA. Other data such as a special certificate recognized by the CA may also be required. Revocation requests may require the matching private key of the certificate being revoked.

Although CMP provides for certificate creation and revocation requests, it does not support CRL query requests. In fact, CRLs are often accessed through out-of-band methods. Since CRLs are often published on LDAP servers, software applications can obtain the CRL from an LDAP server and manually scan the CRL. Another emerging method is the Online Certification Status Protocol (OCSP), but not all CAs support OCSP.

CAs are typically owned and operated by government organizations or trusted private organizations that attempt to provide assurance that certificates issued by them correspond to the person who requested the issuance of the certificate. The phrase *issuing a certificate* means to create a certificate and is not the same as requesting a copy of a published certificate.

## Certificate storage format

The most common format for storing individual certificates is in Abstract Syntax Notation version 1 (ASN.1) format using the Distinguished Encoding Rules (DER). This format is referred to as *DER format*.

### **Keystores:**

A keystore (sometimes called a *keyset*) contains a user's private keys matching the public keys of their certificates.

A unique key label is assigned to every private key, usually by the user, for easy identification. Keystores are password-protected requiring a user to enter a password prior to accessing the keys or adding new keys. And typically, users have their own keystores. Keystores come in many different forms, for example: smart cards, LDAP-based, file-based, and so on. Not only do the forms vary, but so do the methods used to access them and the formats used to store the private key data. Certificate authentication service only supports file-based keystores.

## Certificate Authentication Service implementation

The server side of certificate authentication service publishes certificates and certificate revocation lists (CRLs) that it creates to an LDAP server. The client side of certificate authentication service implements the user authentication, user administration, and user certificate management functions of certificate authentication service.

Certificate authentication service functions as a client/server model. The server side contains a Certificate Authority (CA) for creating and maintaining X.509 version 3 certificates and CRLs. (Typically, an organization uses one CA for the entire organization.) The client side contains the software (commands, libraries, load modules, and configuration files) required by every system participating in PKI authentication. The installation package for the server is **cas.server** and the installation package for the client is **cas.client**.

### **Creating PKI user accounts:**

To create a PKI user account, use the AIX **mkuser** command.

After it is created, each account has a certificate and a private keystore. (Existing accounts can be converted to PKI accounts too, but other steps are required.) The administrator supplies the keystore passwords to the new users, and new users can then log in to the system and change their keystore password.

### *User authentication data flow:*

Users can have multiple certificates associated with their accounts. Each certificate has a unique, user defined tag value associated with it for easy identification, but only one certificate can be specified as the authentication certificate. Certificate authentication service uses a per-user attribute named *auth\_cert* to specify which of the user's certificates is the user's authentication certificate. The value of the *auth\_cert* attribute is the certificate's tag value.

The certificates, tags, matching keystore locations, matching key labels, and other related data are maintained under LDAP on a per-user basis. The combination of the user name and tag allows certificate authentication service to locate the certificate under the LDAP server. For more information on the PKI LDAP layer, see "PKI LDAP Layer (certificate storage)" on page 161.

At login, users supply a user name and password. Using the user name, the system retrieves the user's authentication certificate tag from the user's *auth\_cert* attribute. Combining the user name and tag, the system retrieves the user's certificate, keystore location, and matching key label from LDAP. It checks the validity period values found in the certificate to determine if the certificate has expired or has not reached

its activation date. The system then retrieves the user's private key by using the keystore location, key label, and supplied password. After the private key is retrieved, the system verifies that the private key and certificate match using an internal signing process. If the two match, the user passes the PKI authentication step of the login procedure. (This does not imply that the user is logged in. Several other account checks are performed by the AIX system on a user account before allowing the user access to the system.)

For a certificate to be used as an authentication certificate, the certificate must be signed using a trusted signing key. The signature is stored under LDAP with the certificate for later reference. The implementation requires that a certificate have a signature before the tag can be assigned to *auth\_cert*.

The authentication process does not compare a certificate against a CRL. This is due to performance reasons (CRLs take time to acquire and scan and may be temporarily unavailable), but also due to publishing delays of CRLs (CAs may delay an hour or more before publishing a revoked certificate through a CRL, making certificate revocation a poor substitute for disabling a user's account).

It is also worth noting that authentication does not require a CA. The majority of the work is performed locally by certificate authentication service, with the exception of retrieving data stored under LDAP.

### **Server implementation:**

The server side of certificate authentication service implements a CA written in Java and contains a Registration Authority (RA) along with self-auditing features. It publishes certificates and CRLs that it creates to an LDAP server.

The CA is configurable through a set of configuration files (Java property files). It contains an administrative application called **runpki** that provides sub-commands to start and stop the server among other functions and supports CMP for creating and revoking certificates. The CA requires Java 1.3.1, the IBM DB2 7.1 database, and the IBM Directory 4.1. Due to DB2 requirements, the CA must run under a user account other than the root user.

The server contains the following commands to help install and manage the **cas.server** component:

#### **mksecpki**

This command is used during installation to configure the AIX PKI server components. As part of its tasks, the command creates a certificate authority user account for the certificate authority.

#### **runpki**

This command allows the system administrator to start the server. If the JavaPKI daemons are running, they must first be stopped. The **runpki** command starts the daemon in the background by using the *lb* flags combination. If the daemons need to be started in interactive mode, the administrator can edit the **runpki** command and use the */* flag instead of the *lb* flags.

The **runpki** command must be run after performing an **su** - operation to the user account under which the certificate authority is running. The command is located in the **javapki** directory under the certificate authority user account's home directory. (The **mksecpki** command creates the certificate authority user account.)

For example, if the certificate authority user account is **pkiinst**, then with root authority, type the following:

1. `su - pkiinst`
2. `cd javapki`
3. `runpki`

### **Client implementation:**

The client side of certificate authentication service implements the user authentication, user administration, and user certificate management functions of certificate authentication service.

After it is installed and configured on a system, certificate authentication service integrates into the existing user authentication and administration functions (such as the **mkuser**, **chuser**, **passwd**, and **login** commands) through the use of the AIX Loadable Authentication Module Framework (LAMF). It also adds several commands, libraries, and configuration files to help manage user certificates and keystores.

Certificate authentication service can be used in conjunction with either the AIX LDAP database mechanism or the file-based database mechanism for storing standard AIX attributes. Certificate authentication service always uses LDAP to maintain user certificates, even when the file-based database mechanism is used. For limitations when using the file-based database, see “Certificate Authentication Service planning” on page 168.

The client side of certificate authentication service contains the most user oriented software of the two parts. For this reason, the following sections describe how certificate authentication service maintains and uses the data required for PKI authentication.

#### *General client features:*

The certificate authentication service provides several features and commands for managing and using certificates.

Some of the general features of certificate authentication service include the following:

- Provides user authentication via PKI certificates
- Provides commands to manage user certificates and keystores
- Supports multiple certificates per user
- Supports multiple CA's simultaneously
- Integrates into existing AIX administration commands and authentication (for example, **login**, **passwd**, **mkuser**)
- Generate certificates at user creation time or add certificates after user creation
- Works with either an LDAP user database or the standard AIX file-based user database
- Configurable key sizes and algorithms
- Associates certificates with Process Authentication Groups (PAGs).

#### *General client architecture:*

The client architecture of the Certificate Authentication Service takes a layered approach.

#### *Java daemon:*

At the foundation of the client side is a Java-based daemon using the JCE security package.

The Java daemon manages user keystores, creates key pairs, performs CMP communications, and provides all hashing and encryption functions. Because APIs of PKI service provider packages are not standardized for C applications, a wrapper layer API called the Service Management Layer (SML) provides a normalized API to application programs and daemons.

#### *Service Management Layer:*

Service Management Layer creates certificates and keystores, and manages keystores, but it doesn't manage certificate storage.



The SML service for the Java daemon is named `/usr/lib/security/pki/JSML.sml`. Certificate storage is managed by the PKI LDAP Layer.

### Private Key Storage Through SML

The Java daemon uses PKCS#12 formatted keystore files for storing user keys. The keystores are protected by a single password used to encrypt all the keys in the keystore. The location of a keystore is specified as a URI. By default, certificate authentication service maintains keystore files in the `/var/pki/security/keys` directory.

Keystores are typically limited in size, including file keystores. The SML Layer provides the API for managing keystores.

Certificate authentication service supports only file keystores. It does not support smart card or LDAP keystores. You can support roaming users by placing the file keystores on a shared file system under the same mount point on all systems.

*PKI LDAP Layer (certificate storage):*

Certificate authentication service stores certificates and other certificate related information on a per-user basis in LDAP through the PKI LDAP Layer.

A user account can have multiple certificates associated with it. Each association has a unique, user-specified tag for easy identification and lookup. Certificate authentication service uses the combination of the user's name and the tag to locate a user's certificate association in LDAP.

For performance versus disk space trade-offs, certificate authentication service can save either the entire certificate under LDAP or just a URI reference to the certificate. If a URI reference is used instead of a certificate, certificate authentication service queries the reference to obtain the actual certificate. References are most commonly used in conjunction with a CA which publishes its certificates on an LDAP sever. The types of URI references currently supported by certificate authentication service are LDAP references. Certificate authentication service stores certificates in DER format and expects URI references to refer to DER formatted certificates.

Certificate authentication service also stores the type and location of each certificate's matching keystore and key label in the same record as the certificate association on the LDAP server. This allows users to have more than one keystore and allows certificate authentication service to quickly find a certificate's matching private key. To support roaming users, a user's keystore must reside in the same location on all systems.

Certificate authentication service maintains the `auth_cert` attribute in LDAP on a per-user basis. This attribute specifies the tag of the certificate used for authentication.

All LDAP information is readable by ordinary users, except for the `auth_cert` attribute which is restricted to the LDAP `Idappkiadmin` account. Since the root user has access to the LDAP `Idappkiadmin` password through the `acct.cfg` file, applications running with the effective UID of root can access the `auth_cert` attribute. (This applies to the accessibility of the URI reference value, not to the data referenced by the URI reference value. Typically, the data referenced by the URI reference value is public.) The API for managing the certificate storage is contained in the `libpki.a` library.

*libpki.a library:*

In addition to serving as the home of the SML APIs and the PKI LDAP Layer APIs, the `libpki.a` library houses several subroutines.

The library includes APIs that do the following:

- Manage the new configuration files
- Access certificate specific attributes
- Combine multiple lower layer functions into higher level functions
- Are expected to be common among SML services

**Note:** The APIs are not published.

*Loadable Authentication Module Framework Layer:*

On top of the SML API and PKI LDAP API resides the Loadable Authentication Module Framework (LAMF) layer. LAMF supplies AIX authentication and user administration applications with common authentication and user administration APIs regardless of the underlying mechanism (for example, Kerberos, LDAP, DCE, files).

LAMF uses the SML API and the PKI LDAP API as building blocks in implementing PKI authentication. It does this through the use of load modules that map LAMF's API to different authentication/database technologies. Commands like **login**, **telnet**, **passwd**, **mkuser**, and others use the LAMF API to implement their functions; hence, these commands automatically support new authentication and database technologies when new load modules for these technologies are added to the system.

Certificate authentication service adds a new LAMF load module to the system named **/usr/lib/security/PKI**. The module must be added by the system administrator to the **/usr/lib/security/methods.cfg** file before using PKI for authentication. The module must also be paired with a database type (for example, LDAP) in the **methods.cfg** file before it can be used for authentication. An example of the **methods.cfg** file containing the LAMF module and database definition can be found in "methods.cfg file" on page 181.

Once the definitions are added to **methods.cfg**, the administrator can set the *registry* and *SYSTEM* user attributes (defined in the **/etc/security/user** file) to the new stanza value or values for PKI authentication.

*Client commands:*

Above all the API layers (LAMF, PKI LDAP, and SML) reside the commands.

Besides the standard AIX authentication and user administration commands supporting certificate authentication service (through LAMF), several certificate authentication service specific commands exist. These commands help the user manage certificates and keystores. Below is a list of the commands along with a brief description.

**certadd**

Adds a certificate to the user's account in LDAP and checks if the certificate is revoked.

**certcreate**

Creates a certificate.

**certdelete**

Deletes a certificate from the user's account (i.e., from LDAP).

**certget**

Retrieves a certificate from the user's account (i.e., from LDAP).

**certlink**

Adds a link to a certificate that exists in a remote repository to the user's account in LDAP and checks if the certificate is revoked.

**certlist**

Lists the certificates associated with the user's account contained in LDAP.

**certrevoke**

Revokes a certificate.

**certverify**

Verifies the private key matches the certificate and performs trusted signing.

**keyadd**

Adds a keystore object to a keystore.

**keydelete**

Deletes a keystore object from a keystore.

**keylist**

Lists the objects in a keystore.

**keypasswd**

Changes the password on a keystore.

For more information about these commands, see the *AIX Version 6.1 Commands Reference*.

*Process Authentication Group commands:*

The Process Authentication Group (PAG) commands are new to AIX. PAGs are data items that associate user-authentication data with processes.

For certificate authentication service, if the PAG mechanism is enabled, the user's authentication certificate is associated with the user's login shell. As the shell creates child processes, the PAG propagates to each child.

The PAG mechanism requires the **/usr/sbin/certdaemon** daemon to be enabled in order to provide this functionality. By default, the mechanism is not enabled. Certificate authentication service does not require the PAG mechanism to be enabled, but works with the mechanism if it is enabled.

To enable the **certdaemon** daemon, add the following line to the **/etc/inittab** file:

```
certdaemon:2:wait:/usr/sbin/certdaemon
```

A list of PAG commands along with brief descriptions follows:

**paginit**

Authenticates a user and creates a PAG association.

**pagdel**

Lists authentication information associated with the current process.

**paglist**

Removes existing PAG associations within the current process' credentials.

For more information about these commands, see the *AIX Version 6.1 Commands Reference*.

*User administration commands:*

Similar to user-authentication, certificate authentication service integrates with the AIX user-administration functions through the AIX LAMF. Commands like **chuser**, **lsuser**, **mkuser**, and **passwd** use the LAMF API to implement their functions. Therefore, these commands automatically support new authentication and database technologies when new load modules for these technologies are added to the system.

The subsections below provide a more in-depth look at how PKI authentication affects the user administration commands.

The following commands are affected by the PKI authentication process:

## **chuser**

This command allows the administrator to modify the *auth\_cert* user attribute. This attribute specifies the tag value of the certificate used for authentication. The certificate must be signed by the trusted signing key in order to be used as the authentication certificate. (Certificate attributes, certificate storage attributes, and keystore attributes are not available through this command.)

**lsuser** This command lists the value of the user's *auth\_cert* attribute, as well as, the certificate attributes listed below. The *auth\_cert* attribute specifies the tag value of the certificate used for authentication. (Other certificate attributes, certificate storage attributes, and keystore attributes are not available through this command.)

The certificate attributes listed by the **lsuser** command are as follows:

### **subject-DN**

The user's subject distinguished name.

### **subject-alt-name**

The user's subject alternate name email.

### **valid-after**

The date the user's certificate becomes valid.

### **valid-until**

The date the user's certificate becomes invalid.

**issuer** The distinguished name of the issuer.

## **mkuser**

This command provides an administrator the option of generating a certificate at user creation time. An administrator can use the **mkuser** command to generate a certificate during user creation for users who don't already have an authentication certificate. Optionally, if a user already has an authentication certificate, but no user account, the administrator can create the account without generating a certificate and add the certificate (and keystore) later. The default value for this option is specified in the */usr/lib/security/pki/policy.cfg* file in the *newuser* stanza by the *cert* attribute.

Many default values are required when automatically generating an authentication certificate for a user using the **mkuser** command. Many of these values are specified in the *newuser* stanza of the */usr/lib/security/pki/policy.cfg* file. The *newuser* stanza provides administrative control over these default values. Some of the default values are as follows:

- CA
- Value for the *auth\_cert* attribute
- Location for the keystore
- Password for the keystore
- Private key label
- Domain name for the subject alternate name e-mail field

A behavioral difference between creating a PKI user account and a non-PKI user account is that creating a PKI user account requires a password to encrypt the private key if the **mkuser** command generates an authentication certificate for the account. Since the **mkuser** command is a non-interactive command, the command obtains the password from the *policy.cfg* file and sets the keystore password (the private key password) to this value; therefore, the account is immediately accessible after creation. When creating a non-PKI user account, the **mkuser** command sets the password to an invalid value, preventing accessibility.

## **passwd**

This command modifies the user's keystore password when used on a PKI user account. It enforces the password restriction rules found in the */etc/security/user* file, it enforces the flags attribute found in the */etc/security/passwd* file, and it enforces any rules required by the PKI service provider.

Because file-based keystores encrypt their private keys using the user's password, the root user cannot reset a file-based keystore password without knowing the keystore's current password. If a user forgets their keystore password, the root user will not be able to reset the password unless root knows the keystore's password. If the password is unknown, a new keystore and new certificates may have to be issued to the user.

#### *Configuration files:*

Certificate authentication service uses configuration files for configuring the client-side: **acct.cfg**, **ca.cfg**, and **policy.cfg**.

The SMIT interface provides support for these configuration files. The following sections provide information about the configuration files.

#### **acct.cfg file**

The **acct.cfg** file consists of CA stanzas and LDAP stanzas. The CA stanzas contain private CA information not suitable for the publicly readable **ca.cfg** file, such as CMP reference numbers and passwords. The LDAP stanzas contain private LDAP information not suitable for public access, such as PKI LDAP administrative names and passwords.

For every CA stanza in the **ca.cfg** file, the **acct.cfg** file should contain an equivalently named CA stanza, and all CA stanzas must be uniquely named. The LDAP stanzas are all named `ldap`, and for this reason, a CA stanza cannot be named `ldap`. Also, no stanza can be named `default`. An LDAP stanza must exist, and at least one CA stanza, named `local`, must also exist.

CA stanzas contain the following attributes:

#### **capasswd**

Specifies the CA's CMP password. The length of the password is specified by the CA.

#### **carefnum**

Specifies the CA's CMP reference number.

#### **keylabel**

Specifies the label of the private key in the trusted keystore used to sign certificate requests.

#### **keypasswd**

Specifies the password for the trusted keystore.

#### **rvpasswd**

Specifies the revocation password used for CMP. The length of the password is specified by the CA.

#### **rvrefnum**

Specifies the revocation reference number used for CMP.

The LDAP stanza contains the following attributes:

#### **ldappkiadmin**

Specifies the account name of the LDAP server listed in **ldapservers**.

#### **ldappkiadmpwd**

Specifies the password for the LDAP server's account.

#### **ldapservers**

Specifies the LDAP server name.

#### **ldapsuffix**

Specifies the DN attributes added to a user's certificate DN by the **mkuser** command.

The following is an example **acct.cfg** file:

```
local:
 carefnum = 12345678
 capasswd = password1234
 rvrefnum = 9478371
 rvpasswd = password4321
 keylabel = "Trusted Key"
 keypasswd = joshua

ldap:
 ldappkiadmin = "cn=admin"
 ldappkiadmpwd = secret
 ldapservers = "LDAP server.austin.ibm.com"
 ldapsuffix = "ou=aix,cn=us"
```

For more information, see the *AIX Version 6.1 Files Reference*.

### **ca.cfg file**

The **ca.cfg** file consists of CA stanzas. The CA stanzas contain public CA information used by certificate authentication service for generating certificate requests and certificate revocation requests.

For every CA stanza in the **ca.cfg** file, the **acct.cfg** file should contain an equivalently named CA stanza. Each CA stanza name in the **ca.cfg** file must be unique. At least one stanza named `local` must exist. No stanzas should be named `ldap` or `default`.

CA stanzas contain the following attributes:

#### **algorithm**

Specifies the public key algorithm (for example, RSA).

**crl** Specifies the CA's CRL URI.

**dn** Specifies the base DN used when creating certificates.

#### **keysize**

Specifies the minimum key size in bits.

#### **program**

Specifies the PKI service module file name.

#### **retries**

Specifies the number of retry attempts when contacting the CA.

**server** Specifies the CA's URI.

#### **signinghash**

Specifies the hash algorithm used to sign certificates (for example, MD5).

#### **trustedkey**

Specifies the trusted keystore containing the trusted signing key used for signing authentication certificates.

**url** Specifies the default value for the subject alternate name URI.

The default CA stanza is named `local`. The following is an example **ca.cfg** file:

```
local:
 program = /usr/lib/security/pki/JSML.sm1
 trustedkey = file:/usr/lib/security/pki/trusted.p15
 server = "cmp://9.53.230.186:1077"
 crl = "ldap://dracula.austin.ibm.com/o=aix,c=us"
 dn = "o=aix,c=us"
 url = "http://www.ibm.com/"
```

```
algorithm = RSA
keysize = 512
retries = 5
signinghash = MD5
```

For more information, see the *AIX Version 6.1 Files Reference*.

### **policy.cfg file**

The **policy.cfg** file consists of four stanzas: **newuser**, **storage**, **crl**, and **comm**. These stanzas modify the behavior of some system administration commands.

The **mkuser** command uses the **newuser** stanza. The **certlink** command uses the **storage** stanza. The **certadd** and **certlink** commands use the **comm** and **crl** stanzas.

The **newuser** stanza contains the following attributes:

**ca** Specifies the CA used by the **mkuser** command when generating a certificate.

**cert** Specifies whether the **mkuser** command generates a certificate (**new**) or not (**get**) by default.

#### **domain**

Specifies the domain part of the certificate's subject alternate name e-mail value used by the **mkuser** command when generating a certificate.

#### **keysize**

Specifies the minimum encryption key size in bits used by the **mkuser** command when generating a certificate.

#### **keystore**

Specifies the keystore URI used by the **mkuser** command when generating a certificate.

#### **keyusage**

Specifies the certificate's key usage value used by the **mkuser** command when generating a certificate.

**label** Specifies the private key label used by the **mkuser** command when generating a certificate.

#### **passwd**

Specifies the keystore's password used by the **mkuser** command when generating a certificate.

#### **subalturi**

Specifies the certificate's subject alternate name URI value used by the **mkuser** command when generating a certificate.

**tag** Specifies the *auth\_cert* tag value used by the **mkuser** command when creating a user when **cert = new**.

#### **validity**

Specifies the certificate's validity period value used by the **mkuser** command when generating a certificate.

#### **version**

Specifies the version number of the certificate to be created. The value 3 is the only supported value.

The **storage** stanza contains the following attributes:

#### **replicate**

Specifies whether the **certlink** command saves a copy of the certificate (**yes**) or just the link (**no**).

The **crl** stanza contains the **check** attribute, which specifies whether the **certadd** and **certlink** commands should check the CRL (**yes**) or not (**no**).

The `comm` stanza contains the **timeout** attribute which specifies the timeout period in seconds used by **certadd** and **certlink** when requesting certificate information using HTTP (for example, retrieving CRLs).

The following is an example of the **policy.cfg** file:

```
newuser:
 cert = new
 ca = local
 passwd = pki
 version = "3"
 keysize = 512
 keystore = "file:/var/pki/security/keys"
 validity = 86400

storage:
 replicate = no

crl:
 check = yes

comm:
 timeout = 10
```

For more information, see the *AIX Version 6.1 Files Reference*.

#### *Audit-log events:*

The Certificate Authentication Service (CAS) client generates several audit-log events.

- CERT\_Create
- CERT\_Add
- CERT\_Link
- CERT\_Delete
- CERT\_Get
- CERT\_List
- CERT\_Revoke
- CERT\_Verify
- KEY\_Password
- KEY\_List
- KEY\_Add
- KEY\_Delete

#### *Trace events:*

The Certificate Authentication Service (CAS) client generates trace events.

The CAS client generates several new trace events in the 3B7 and 3B8 range.

## **Certificate Authentication Service planning**

Certificate Authentication Service (CAS) is available beginning with AIX 5.2. The minimum software requirements for CAS are a DB2 server, an IBM Directory server, and a certificate authentication service server. All can be installed on one system or on a combination of systems. Each enterprise must determine the best choice for their environment.

This section provides information on planning for certificate authentication service, as follows:

#### ***Certificate considerations:***



Certificate authentication service supports X.509 version 3 certificates. It also supports several version 3 certificate attributes, but not all certificate attributes.

For a list of supported certificate attributes, see the **certcreate** command and the **ca.cfg** file. Certificate authentication service contains limited support of the Teletex character set. Specifically, only 7-bit (ASCII subset of) Teletex is supported by certificate authentication service.

#### ***Keystore considerations:***

Certificate authentication service supports keystore files. Smart cards, LDAP keystores, and other types of keystores are not supported.

By default, user keystores are kept in the local file system under the **/var/pki/security/keys** directory. Because the keystores are local to the system, they cannot be accessed by other systems; thus, user authentication will be restricted to the system containing the user's keystore. To allow for roaming users, either copy the user's keystore to the identical location with the same keystore name on other systems or place the keystores on a distributed file system.

**Note:** Care must be taken to ensure that access permission to the user's keystore remains unchanged. (In AIX, every certificate in LDAP contains the path name to the private keystore containing the certificate's private key. The keystore must exist at the path name specified in LDAP in order to be used for authentication.)

#### ***User registry considerations:***

Certificate authentication service supports an LDAP user-registry. LDAP is also the recommended user registry type to use with certificate authentication service.

Certificate authentication service also supports a file-based user registry. Certain restrictions must be enforced by the administrator for file-based PKI to work correctly. Specifically, identically named user accounts on different systems participating in PKI authentication must refer to the same account.

For example, user *Bob* on *system A* and user *Bob* on *system B* must refer to the same user *Bob*. This is because certificate authentication service uses LDAP to store certificate information on a per user basis. The user name is used as the indexing key to access this information. Because file-based registries are local to each system and LDAP is global to all systems, the user names on all systems participating in PKI authentication must map to unique user names in the LDAP namespace. If user *Bob* on *system A* is different from user *Bob* on *system B*, either only one of the *Bob*'s can participate in PKI authentication or each *Bob* account must use a different LDAP namespace/server.

#### ***Configuration considerations:***

For configuration simplicity, consider maintaining the three configuration files (**acct.cfg**, **ca.cfg**, and **policy.cfg**) on a distributed file system using symbolic links to avoid having to modify configuration files on every system.

Maintain proper access-control settings on these files. This situation may increase your security vulnerability because the information in these files will be transferred across your network.

#### ***Security considerations:***

The **acct.cfg** and **ca.cfg** files contain sensitive reference numbers, passwords, and certificate information.

## acct.cfg file

The **acct.cfg** file contains sensitive CA reference numbers and passwords (see the **carefnum**, **capasswd**, **rvrefnum**, and **rvpasswd** attribute descriptions for **acct.cfg**). These values are used solely for CMP communications with the CA when creating a certificate and revoking a certificate, respectively. If compromised, the compromiser may be able to create certificates at will, and revoke anyone's certificate at will.

To limit the exposure, consider restricting certificate creation or revocation to a small number of systems. The **carefnum** and **capasswd** attribute values are required only on systems where certificates are created (either through the **certcreate** or **mkuser** commands). This may imply limiting user account creation to the same set of systems.

**Note:** The **mkuser** command can be configured to automatically create a certificate during user creation or it can create an account without a certificate, whereby the administrator must create and add the certificate at a later time.

Similarly, the **rvrefnum** and **rvpasswd** attribute values are required only on systems where certificates are to be revoked (through the **certrevoke** command).

The **acct.cfg** file also contains sensitive trusted signing key information (see the **keylabel** and **keypasswd** attribute descriptions for the **acct.cfg** file). These values are used solely for special certificate verification operations. If compromised, the compromiser may be able to forge verified certificates.

To limit the exposure, consider restricting certificate verification to a small number of systems. The **keylabel** and **keypasswd** attribute values of the **acct.cfg** file and the **trustedkey** attribute value of the **ca.cfg** file are required only on systems where certificate verification is required. Specifically, on systems where the **mkuser** (with automatic certificate creation enabled) and **certverify** commands are required.

## Active new accounts

When creating a PKI user account, if the **cert** attribute of the **newuser** stanza in the **policy.cfg** file is set to **new**, the **mkuser** command creates an active PKI account complete with a working certificate and password. The password on the account is specified by the **passwd** attribute in the **newuser** stanza. Because keystores require a password in order to store private keys. This differs from other types of user account creations where the administrator must first create the account, then set the password before the account is activated.

## The root user and keystore passwords

Unlike other account types where the root user can change an account's password without knowing the account's password, PKI accounts do not allow this. This is because account passwords are used to encrypt keystores and keystores cannot be decrypted without knowing the password. When users forget their passwords, new certificates must be issued and new keystores created.

### ***Other Certificate Authentication Service considerations:***

There are several factors to consider when planning for the Certificate Authentication Service (CAS).

- Certificate authentication service contains its own certificate authority (CA). Other CA implementations are not supported by certificate authentication service.
- The larger the key size, the more time required to generate key pairs and to encrypt data. Hardware based encryption is not supported.
- Certificate authentication service uses the IBM Directory for LDAP. Other LDAP implementations are not supported by certificate authentication service.
- Certificate authentication service uses DB2 for database support. Other database implementations are not supported by certificate authentication service.

- Certificate authentication service requires all commands, libraries, and daemons run in a Unicode environment.

## Packaging of Certificate Authentication Service

This table shows the package components of the Certificate Authentication Service (CAS).

Table 11. Packaging of Certificate Authentication Service

| Package Name | Fileset               | Contents                                                                                                                                                                                   | Dependencies                                                                                                                                                                                                                                  | Installation          |
|--------------|-----------------------|--------------------------------------------------------------------------------------------------------------------------------------------------------------------------------------------|-----------------------------------------------------------------------------------------------------------------------------------------------------------------------------------------------------------------------------------------------|-----------------------|
| cas.server   | cas.server.rte        | Certificate Authority (CA)                                                                                                                                                                 | <ul style="list-style-type: none"> <li>• AIX 5.2</li> <li>• Java131 (ships with AIX base media)</li> <li>• Java131 Security Extensions (ships with Expansion Pack)</li> <li>• IBM Directory Server (LDAP)</li> <li>• DB2 7.1</li> </ul>       | Manual                |
| cas.client   | cas.client.rte        | <ul style="list-style-type: none"> <li>• Cert commands</li> <li>• PKI Auth Load Module</li> <li>• libpki.a</li> <li>• SML Module</li> <li>• Config Files</li> <li>• Java Daemon</li> </ul> | <ul style="list-style-type: none"> <li>• AIX 5.2</li> <li>• Java131 (ships with AIX base media)</li> <li>• Java131 Security Extensions (ships with Expansion Pack)</li> <li>• IBM Directory Client (LDAP)</li> <li>• PAG (assumed)</li> </ul> | Manual                |
| cas.msg      | cas.msg.[lang].client | Message catalogs                                                                                                                                                                           | cas.client                                                                                                                                                                                                                                    | Manual                |
| bos          | bos.security.rte      | PAG commands and daemon                                                                                                                                                                    | not applicable                                                                                                                                                                                                                                | Installed with kernel |

The **cas.server** package contains the CA and installs in the **/usr/cas/server** and **/usr/cas/client** directories. An organization typically uses only one CA, and therefore, this package is installed manually. This package prerequisites the IBM Directory server side, **db2\_07\_01.client**, **Java131.rte**, and **Java131.ext.security**. The **Java131.rte package** is installed by default when the AIX 5.2 operating system is installed, but the other packages are manually installed.

In order for the **db2\_07\_01.client** package to work, the **db2\_07\_01.server** package must be installed on a system that is on the network.

The **cas.client** package contains the files required for every client system supporting certificate authentication service. Without this package, a system cannot participate in AIX PKI authentication.

## Certificate Authentication Service installation and configuration

The following procedures are used to install and configure the Certificate Authentication Services (CAS).

### **LDAP server for PKI installation and configuration:**

The following are some possible scenarios when installing and configuring LDAP for PKI user certificate data.

*Installing the LDAP server:*

Detailed instructions for installing the IBM Directory Server software can be found in the product documentation contained in the **ldap.html.en\_US.config** fileset. After installing the **ldap.html.en\_US.config** fileset, the documentation can be viewed using a Web browser at the following URL: **file:/usr/ldap/web/C/getting\_started.htm**.

Perform the following steps to install the LDAP server:

1. Login as the **root** user.
2. Place volume 1 of the AIX Base Operating System CDs in the CD-ROM drive.
3. Type `smitty install_latest` at the command line and press Enter.
4. Select **Install Software**.
5. Select the input device or software directory containing the IBM Directory Server software and press Enter.
6. Use the **F4** key to list the install packages in the **Software to Install** field.
7. Select the LDAP server package and press Enter.
8. Verify that the **AUTOMATICALLY install requisite software** option is set to **YES**, and press Enter. This will install the LDAP server and client filesets and the DB2 backend database filesets.

The filesets installed include the following:

- LDAP client **.adt** (Directory Client SDK)
  - LDAP client **.dmt** (Directory Client DMT)
  - LDAP client **.java** (Directory Client Java)
  - LDAP client **.rte** (Directory Client Run-time Environment)
  - LDAP server **.rte** (Directory Server Run-time Environment)
  - LDAP server **.admin** (Directory Server)
  - LDAP server **.cfg** (Directory Server Config)
  - LDAP server **.com** (Directory Server Framework)
  - **db2\_07\_01.\*** (DB2 Run-time Environment and associated filesets)
9. Install the DB2 package, **db2\_07\_01.jdbc**. The DB2 package, **db2\_07\_01.jdbc**, is located on the Expansion Pack CD. Use the installation procedure listed above to install the **db2\_07\_01.jdbc** package.

#### *Configuring the LDAP server:*

After the LDAP and DB2 filesets have been installed, the LDAP server must be configured.

Even though the configuration can be done through the command line and file editing, for ease of administration and configuration, the LDAP web administrator is used. This tool requires a web server.

The Apache web server application is located on the AIX Toolbox for LINUX Applications CD. Use either the SMIT interface or the **geninstall** command to install the Apache web server. Other web servers can also be used, see the LDAP documentation for details.

You can find detailed instructions for configuring LDAP in the product HTML documentation. To configure the LDAP, perform the following steps:

1. Use **ldapcfg** to set the admin DN and password for the LDAP database. The administrator is the **root** user of the LDAP database. To configure an administrator DN of **cn=admin** with a password of **secret**, type the following:

```
ldapcfg -u cn=admin -p secret
```

The DN and password will be required later when configuring each client. Specifically, the DN and password will be used as the *ldappkiadmin* and *ldappkiadmpwd* attributes of an **ldap** stanza in the **acct.cfg** file.

2. Configure the web administrator tool using the location of the web server configuration file, as follows:  
# ldapcfg -s apache -f /etc/apache/httpd.conf
3. Restart the web server. For the Apache server, use the command:  
# /usr/local/bin/apachectl restart
4. Access the web administrator using the URL **http:// hostname/ldap**. Then login using the LDAP administrator DN and password configured in step 2.
5. Using the web administrator tool, follow the directions to configure the DB2 database backend and restart the LDAP server.

### *Configuring the LDAP Server for PKI:*

Certificate authentication service requires two separate LDAP directory information trees. One tree is used by the CA for publishing certificates and CRLs. The other tree is used by each client for storing and retrieving per-user PKI data.

The following steps configure the LDAP directory information tree used for storing and retrieving per-user PKI data.

1. **Add the LDAP Configuration Suffix Entry.** The default suffix for the PKI data is **cn=aixdata**. This places the PKI certificate data below the default suffix for all AIX data. The default data root for the PKI data is **ou=pkidata,cn=aixdata**. All PKI data is placed under this location.

#### **PKI Data Suffix**

##### **cn=aixdata**

Common suffix for all AIX data. May already exist if LDAP server is being used for other AIX data.

The suffix configuration entry can be added through the web administrator tool, or by directly editing the LDAP server configuration file.

To add the suffix configuration entry using the Web administrator, do the following:

- a. Select **Settings** from the left side menu.
- b. Select **Suffixes**.
- c. Enter the necessary suffix for the PKI data, and then click the **Update** button.
- d. Restart the LDAP server, after the suffix is successfully added.

To add the suffix configuration entry by editing the LDAP server configuration file, do the following:

- a. In the **/usr/ldap/etc/slapd32.conf** file, locate the line containing  
ibm-slapdSuffix: cn=localhost

This is the default system suffix.

- b. Add the necessary **ibm-slapdSuffix** entry for the PKI data. For example, you can add a suffix entry similar to the following:

```
ibm-slapdSuffix: cn=aixdata
```

- c. Save the configuration file changes.
- d. Restart the LDAP server.

2. **Add the PKI Data Suffix, Root, and ACL Database Entries.** The Data Root is the point in the LDAP directory structure under which all the PKI data resides. The ACL is the Access Control List for the Data Root that sets the access rules for all the PKI data. The **pkiconfig.ldif** file is supplied to add the suffix, root, and ACL entries to the database.

- a. First, add the suffix and root database entries and the PKI data administrator password. The first part of the file adds the default suffix entries to the database and sets the password as follows:

```

dn: cn=aixdata
objectclass: top
objectclass: container
cn: aixdata

dn: ou=pkidata,cn=aixdata
objectclass: organizationalUnit
ou: cert
userPassword: <<password>>

```

- b. Edit the **pkiconfig.ldif** file and replace the <<password>> character string after the **userPassword** attribute with your password for the PKI data administrator.

The DN and **userPassword** values will be required later when configuring each client. Specifically, the DN (ou=pkidata,cn=aixdata) and value for *password* will be used as the **ldappkiadmin** and **ldappkiadmpwd** attributes of an ldap stanza in the **acct.cfg** file.

The second part of the file changes the ownership and adds the ACL for the PKI data as follows:

```

dn: ou=pkidata,cn=aixdata
changetype: modify
add: entryOwner
entryOwner: access-id:ou=pkidata,cn=aixdata
ownerPropagate: true

dn: ou=pkidata,cn=aixdata
changetype: modify
add: aclEntry
aclEntry: group:cn=anybody:normal:grant:rsc:normal:deny:w
aclEntry: group:cn=anybody:sensitive:grant:rsc:sensitive:deny:w
aclEntry: group:cn=anybody:critical:grant:rsc:critical:deny:w
aclEntry: group:cn=anybody:object:deny:ad aclPropagate: true

```

**Note:** To avoid jeopardizing the integrity of your PKI implementation, *do not* make any changes to the ACL settings.

The **pkiconfig.ldif** file can be edited to use a suffix other than the default, however this is recommended only for experienced LDAP administrators. The **ldif** file can then be applied to the database using the **ldapadd** command below.

- c. Replace the values for the **-D** and **-w** options with your local LDAP administrator DN and password, as follows:

```
ldapadd -c -D cn=admin -w secret -f pkiconfig.ldif
```

3. **Restart the LDAP Server.** Restart the LDAP server using the web administrator tool, or by stopping and restarting the **slapd** process.

### **Installing and configuring the Certificate Authentication Service:**

The following steps are used to install and configure the certificate authentication service.

To install and configure the certificate authentication service, do the following:

1. Install the Java security filesets (**Java131.ext.security.\***) from the Expansion Pack CD. The required packages are as follows:
  - **Java131.ext.security.cmp-us** (Java Certificate Management)
  - **Java131.ext.security.jce-us** (Java Cryptography Extension)
  - **Java131.ext.security.jsse-us** (Java Secure Socket Extension)
  - **Java131.ext.security.pkcs-us** (Java Public Key Cryptography)
2. Move the **ibmjcaprovider.jar** file from **/usr/java131/jre/lib/ext** to another directory. This file conflicts with the Java security filesets and must be moved for correct functioning of the certificate authentication service.
3. Install the certificate authentication service server fileset (**cas.server.rte**) from the Expansion Pack CD.

## Configuring the Certificate Authentication Service server to work with LDAP:

If the Certificate Authentication Service (CAS) is to be used with LDAP, CAS must be configured to work with LDAP.

To configure the CAS server to work with LDAP, perform the following steps:

1. If not already installed, then install the IBM Directory client package on the system supporting the **cas.server** package.

2. If not already configured, then configure the IBM Directory client, as follows:

```
ldapcfg -l /home/ldapdb2 -u "cn=admin" -p secret -s apache \
-f /usr/local/apache/conf/httpd.conf
```

It is assumed that the Web Server is the Apache Web Server in the above configuration command.

3. Add the following suffix to the **slapd.conf** file, as follows:

```
ibm-slapdSuffix: o=aix,c=us
```

You can specify a different distinguished name instead of o=aix,c=us.

4. Run the **slapd** command, as follows:

```
/usr/bin/slapd -f /etc/slapd32.conf
```

5. Add the object classes, as follows:

```
ldapmodify -D cn=admin -w secret -f setup.ldif
```

where **setup.ldif** contains the following:

```
dn: cn=schema
changetype: modify
add: objectClasses
objectClasses: (2.5.6.21 NAME 'pkuser' DESC 'auxiliary class for non-CA certificate owners'
 SUP top AUXILIARY MAY userCertificate)
```

```
dn: cn=schema
changetype: modify
add: objectClasses
objectClasses: (2.5.6.22 NAME 'pkICA' DESC 'class for Cartification Authorities' SUP top
 AUXILIARY MAY (authorityRevocationList $ caCertificate $ certificateRevocationList $
 crossCertificatePair))
```

```
dn:cn=schema
changetype: modify
replace: attributetypes
attributetypes: (2.5.4.39 NAME ('certificateRevocationList'
 'certificateRevocationList;binary') DESC ' ' SYNTAX 1.3.6.1.4.1.1466.115.121.1.5
 SINGLE-VALUE)
```

```
replace:ibmattributetypes
ibmattributetypes:(2.5.4.39 DBNAME ('certRevocationLst' 'certRevocationLst')
 ACCESS-CLASS NORMAL)
```

6. Add the entries:

```
ldapadd -D cn=admin -w secret -f addentries.ldif
```

where **addentries.ldif** contains the following:

```
dn: o=aix,c=us
changetype: add
objectclass: organization
objectclass: top
objectclass: pkICA
o: aix
```

**Note:** Sample **addentries.ldif** and **setup.ldif** files are provided in the **cas.server** package.

7. Stop and start the **slapd** daemon.

## Creating the Certificate Authority:

The following steps are used to create the certificate authority.

1. Create a reference file. The reference file contains one or more certificate creation reference number and password pairs. A pair represents the authentication information accepted by the certificate authentication service server when a certificate authentication service client attempts to authenticate to the server during the creation of a certificate (typically using the CMP protocol). The format of the file is a reference number followed by a password, both on separate lines. For example:

```
12345678
password1234
87654321
password4321
```

where 12345678 and 87654321 are reference numbers, and password1234 and password4321 are their respective passwords. Blank lines are not allowed. Space characters should not precede or follow reference numbers or passwords. At least one reference number and password must exist in the file. An example file can be found in **/usr/cas/server/iafile**. You will need to reference these values each time you set up a client.

2. Configure the CA using the **mksecpki** command as follows:

```
mksecpki -u pkiuser -f /usr/cas/server/iafile -p 1077 -H ldap.cert.mydomain.com \
-D cn=admin -w secret -i o=aix,c=us
```

Information on the **mksecpki** flags follows:

- u Specifies a user account name where the certificate authentication service server will be installed.
- f Specifies the reference file created in the previous step.
- p Specifies a port number for the LDAP server.
- H Specifies the LDAP server host name or IP address.
- D Specifies the LDAP administrator's common name.
- w Specifies the LDAP administration password.
- i Specifies the LDAP branch where the user certificate data will reside.

The **mksecpki** command automatically generates the trusted signing key with a key label of **TrustedKey**, the password of the CA user account, and places it in the **/usr/lib/security/pki/trusted.pkcs12** keystore file. It's not necessary to perform the steps in "Creating the trusted signing key" unless you need to generate multiple keys or want a trusted signing key with a different key label and/or password.

## Creating the trusted signing key:

The **mksecpki** command automatically generates a trusted signing key with a key label of *TrustedKey*, the password of the CA user account, and places it in the **/usr/lib/security/pki/trusted.pkcs12** keystore file. If you need to generate a new trusted signing key or multiple trusted signing keys, then this section provides the steps needed to generate a trusted signing key.

All certificate authentication service clients where certificate creation and revocation are allowed require a trusted signing key for signing the user's authentication certificate. The key is saved in a separate keystore and is made available to all systems where certificates can be created. A single key can be used by all systems or, for a more secure approach, multiple keys can be created and distributed.

To create a trusted key, use the **/usr/java131/bin/keytool** command. Use a file name of a non-existing file. The **keytool** command prompts for a keystore password and key password. Both the keystore password and key password must be identical for certificate authentication service to access the key in the keystore. Run the **keytool** command as follows:



```
keytool -genkey -dname `cn=trusted key' -alias `TrustedKey' -keyalg RSA \
-keystore filename.pkcs12 -storetype pkcs12ks
```

In this example, the trusted key label is *TrustedKey* and the trusted keystore password is user-supplied. Remember these values, because you will need them when configuring the certificate authentication service clients. When configuring a certificate authentication service client, the **keylabel** and **keypasswd** attributes in the **acct.cfg** file will need to be set to the trusted key label and trusted keystore password, respectively.

For security reasons, make sure the keystore file (*filename.pkcs12*) is read and write protected. Only the root user should have access to this file. The trusted key should be the only object in the keystore.

### ***Configuring the Certificate Authentication Service client:***

There are many configuration options on the client side of Certificate Authentication Service. The following sections provide the configuration procedure required for each system participating in PKI authentication.

### **Trusted Signing Key installation**

For information on creating the trusted signing key, see “Creating the trusted signing key” on page 176. The default location for the trusted keystore is in the **/usr/lib/security/pki** directory.

For security reasons, make sure the keystore file is read and write protected. Only the root user should have access to this file.

### **Editing the acct.cfg file**

Remove any ldap stanzas that may exist in the **/usr/lib/security/pki/acct.cfg** file using a text-based editor like the **vi** command.

### *Certificate Authority account configuration:*

Minimally, the local CA account must be configured. By default, the local CA account exists, but must be modified to match your environment.

Certificate authentication service supports the use of multiple CA's by a single system through stanza-based configuration files. The default CA stanza name of *local* is used when a CA is not specified by a user or by the software. All systems must have a valid local stanza definition in the appropriate certificate authentication service configuration files. Only one CA may have a stanza name of *local*. All other CA's must have a unique stanza name. CA stanza names cannot be *ldap* or *default*.

The following sections guide you through the SMIT configuration screens for configuring the local CA.

### *Change/Show a Certificate Authority:*

You can change or show a Certificate Authority (CA).

Perform the following steps are used to change/show a CA:

1. Run PKI SMIT, as follows:  
`smitty pki`
2. Select **Change / Show a Certificate Authority**.
3. Type *local* for the **Certificate Authority Name** field and press Enter.
4. Set the **Service Module Name** field to `/usr/lib/security/pki/JSML.sm1`. This is the default SML load module. This field maps to the **program** attribute in the **/usr/lib/security/pki/ca.cfg** file.

5. Ignore the **Pathname of CA's Certificate** field. This field maps to the **certfile** attribute in the **/usr/lib/security/pki/ca.cfg** file.
6. Set the **Pathname of CA's Trusted Key** field to a URI that is the location of the trusted keystore on the local system. Only file-based keystores are supported. The typical location for the trusted keystore is in the **/usr/lib/security/pki** directory. (See "Configuring the Certificate Authentication Service client" on page 177.) This field maps to the **trustedkey** attribute in the **/usr/lib/security/pki/ca.cfg** file.
7. Set the **URI of the Certificate Authority Server** field to a URI that is the location of the CA (**cmp://myserver:1077**). This field maps to the **server** attribute in the **/usr/lib/security/pki/ca.cfg** file.
8. Ignore the **Certificate Distribution Point** field. This field maps to the **cdp** attribute in the **/usr/lib/security/pki/ca.cfg** file.
9. Set the **Certificate Revocation List (CRL) URI** field. This field specifies the URI that should be set to the location of the certificate revocation list for this CA. This is typically an LDAP URI, for example:  
`ldap://cr1server/o=XYZ,c=us`

This field maps to the **crl** attribute in the **/usr/lib/security/pki/ca.cfg** file.

10. The **Default Certificate Distinguished Name** field specifies the baseline DN used when creating certificates (for example, **o=XYZ,c=us**). This field is *not* required. This field maps to the **dn** attribute in the **/usr/lib/security/pki/ca.cfg** file.
11. The **Default Certificate Subject Alternate Name URI** field specifies the default subject alternate name URI used when creating certificates if a subject alternate name URI is not provided at creation time. This field is *not* required. This field maps to the **url** attribute in the **/usr/lib/security/pki/ca.cfg** file.
12. The **Public Key Algorithm** field specifies the public key algorithm used when creating a certificate. The choices are RSA and DSA. If neither are specified, the system defaults to RSA. This field maps to the **algorithm** attribute in the **/usr/lib/security/pki/ca.cfg** file.
13. The **Public Key Size (in bits)** field specifies the bit size of the public key algorithm. This field is in bits, not bytes, and this value may be rounded up by the underlying public key mechanism to support the next feasible byte size. (Typically, rounding occurs when the number of bits is not an even multiple of 8). Example values are 512, 1024, and 2048. If this field is not specified, the system defaults to 1024 bits. This field maps to the **keysize** attribute in the **/usr/lib/security/pki/ca.cfg** file.
14. The **MAX. Communications Retries** field specifies the number of times the system attempts to contact the CA (when creating or revoking a certificate) before giving up. The system defaults to 5 attempts. This field maps to the **retries** attribute in the **/usr/lib/security/pki/ca.cfg** file.
15. The **Signing Hash Algorithm** field specifies the hash algorithm used when signing an authentication certificate. The choices are MD2, MD5, and SHA1. The system defaults to MD5. This field maps to the **signinghash** attribute in the **/usr/lib/security/pki/ca.cfg** file.
16. Press Enter to commit the changes.

#### *Change/Show Certificate Authority accounts:*

Perform the following steps to change/show the Certificate Authority (CA) accounts.

1. Run PKI SMIT, as follows:  
`smitty pki`
2. Select **Change/Show CA Accounts**.
3. Type **local** for the **Certificate Authority Name** field and press Enter.
4. The **Certificate Creation Reference Number** field specifies the CA's reference number used in creating a certificate. The creation reference number must be composed of all digits and be at least 7 digits in length. The reference number is defined by the CA. (See "Creating the Certificate Authority" on page 176.) This field maps to the **carefnum** attribute in the **/usr/lib/security/pki/acct.cfg** file.
5. The **Certificate Creation Password** field specifies the CA's reference password used when creating a certificate. The creation password must be composed of 7-bit ASCII alpha-numeric characters and be at least 12 characters in length. The creation password is defined at the CA and must be the matching

password to the creation reference number above. (See “Creating the Certificate Authority” on page 176.) This field maps to the **capasswd** attribute in the **/usr/lib/security/pki/acct.cfg** file.

6. The **Certificate Revocation Reference Number** field specifies the reference number used when revoking a certificate. The revocation reference number must be composed of all digits and be at least 7 digits in length. The revocation reference number is sent to the CA during each certificate creation and is associated with the certificate by the CA. To revoke a certificate, the same revocation reference number (and revocation password) must be sent during revocation as was sent when creating the certificate. This field maps to the **rvrefnum** attribute in the **/usr/lib/security/pki/acct.cfg** file.
7. The **Certificate Revocation Password** field specifies the reference password used when revoking a certificate. The revocation password must be composed of 7-bit ASCII alpha-numerics and be at least 12 characters in length. The revocation password is sent to the CA during each certificate creation and is associated with the certificate by the CA. To revoke a certificate, the same revocation password (and revocation reference number) must be sent during revocation as was sent when creating the certificate. This field maps to the **rvpasswd** attribute in the **/usr/lib/security/pki/acct.cfg** file.
8. The **Trusted Key Label** field specifies the label (sometimes called *alias*) of the trusted signing key located in the trusted keystore. The trusted key label value is the value from “Creating the trusted signing key” on page 176. This field maps to the **keylabel** attribute in the **/usr/lib/security/pki/acct.cfg** file.
9. The **Trusted Key Password** field specifies the password of the trusted signing key located in the trusted keystore. The trusted key password value is the value from “Creating the trusted signing key” on page 176. This field maps to the **keypasswd** attribute in the **/usr/lib/security/pki/acct.cfg** file.
10. Press Enter to commit the changes.

#### *Adding a Certificate Authority LDAP Account:*

The following steps are used to add a Certificate Authority (CA) LDAP account.

1. Run PKI SMIT, as follows  

```
smitty pki
```
2. Select **Add an LDAP Account**.
3. The **Administrative User Name** field specifies the LDAP administrative account DN. The administrative user name for the CA LDAP account is the same name used in both “Configuring the LDAP server” on page 172 and “Configuring the Certificate Authentication Service server to work with LDAP” on page 175. The value should be **cn=admin**. It is used by the client side to communicate with the LDAP server when accessing CA LDAP data. This field maps to the **ldappkiadmin** attribute in the **/usr/lib/security/pki/acct.cfg** file. For example:  

```
ldappkiadmin = "cn=admin"
```
4. The **Administrative Password** field specifies the LDAP administrative account password. The administrative password is the same password used in both “Configuring the LDAP server” on page 172 and “Configuring the Certificate Authentication Service server to work with LDAP” on page 175. This field maps to the **ldappkiadmpwd** attribute in the **/usr/lib/security/pki/acct.cfg** file. For example:  

```
ldappkiadmpwd = secret
```
5. The **Server Name** field specifies the name of the LDAP server and must be defined in every LDAP stanza. The value is a single LDAP server name. This field maps to the **ldapservers** attribute in the **/usr/lib/security/pki/acct.cfg** file. For example:  

```
ldapservers = ldapservers.mydomain.com
```
6. The **Suffix** field specifies the DN suffix for the directory information tree where the data resides. The suffix is the value of the **ibm-slapsuffix** attribute used in “Configuring the Certificate Authentication Service server to work with LDAP” on page 175. This attribute must be defined in every LDAP stanza. This field maps to the **ldapsuffix** attribute in the **/usr/lib/security/pki/acct.cfg** file. For example:  

```
ldapsuffix = "ou=aix,cn=us"
```

7. Press Enter to commit the changes.

*Add a PKI Per-User LDAP account:*

Use this procedure to add a PKI Per-User LDAP account.

Perform the same steps as in “Adding a Certificate Authority LDAP Account” on page 179, except use the values used in the **Adding the PKI Suffix** and **ACL Database Entries** step in “Configuring the LDAP Server for PKI” on page 173. Use the following values:

- Administrative User Name (ou=pkidata,cn=aixdata),
- Administrative Password (*password*),
- Server Name (*site specific*),
- Suffix (ou=pkidata,cn=aixdata).

Press Enter to commit the changes.

*Change/Show the Policy:*

The following steps are used to change/show the policy.

1. Run PKI SMIT, as follows:

```
smitty pki
```

2. Select **Change / Show the Policy**.

- The **Create Certificates for New Users** field specifies whether the **mkuser** command generates a certificate and keystore for the new user (*new*), or if the administrator provides a certificate and keystore after the user is created (**get**). This field maps to the **cert** attribute of the newuser stanza in the **/usr/lib/security/pki/policy.cfg** file.
- The **Certificate Authority Name** field specifies the CA used by the **mkuser** command when generating a certificate. The field value must be a stanza name found in the **ca.cfg** file; for example, *local*. This field maps to the **ca** attribute of the newuser stanza in the **/usr/lib/security/pki/policy.cfg** file.
- The **Initial User Password** field specifies the password used by the **mkuser** command when creating a user’s keystore. This field maps to the **passwd** attribute of the newuser stanza in the **/usr/lib/security/pki/policy.cfg** file.
- The **Certificate Version** field specifies the certificate version used by the **mkuser** command when generating a certificate. Currently, the only supported value is 3, which represents X.509v3. This field maps to the **version** attribute of the newuser stanza in the **/usr/lib/security/pki/policy.cfg** file.
- The **Public Key Size** field specifies the size (in bits) of the public key used by the **mkuser** command when generating a certificate. This field maps to the **keysize** attribute of the newuser stanza in the **/usr/lib/security/pki/policy.cfg** file.
- The **Keystore Location** field specifies the keystore directory in URI format used by the **mkuser** command when creating a keystore. This field maps to the **keystore** attribute of the newuser stanza in the **/usr/lib/security/pki/policy.cfg** file.
- The **Validity Period** field specifies the certificate’s requested validity period used by the **mkuser** command when generating a certificate. The requested validity period may or may not be honored by the CA when creating the certificate. The period can be specified in seconds, days, or years. If just a number is provided, it is assumed to be in seconds. If the letter d immediately follows the number, it is interpreted as days. If the letter y immediately follows the number, it is interpreted as years. Example values are:
  - 1y (for 1 year)
  - 30d (for 30 days)
  - 2592000 (for 30 days represented in seconds)

This field maps to the **validity** attribute of the newuser stanza in the **/usr/lib/security/pki/policy.cfg** file.

- The **Replicate Non-Local Certificates** field specifies whether the **certlink** command saves a copy of a certificate (Yes) or just the link to the certificate (No). This field maps to the **replicate** attribute of the storage stanza in the **/usr/lib/security/pki/policy.cfg** file.
- The **Check Certificate Revocation Lists** field specifies whether the **certadd** and **certlink** commands check the CRL before performing their tasks (Yes) or not (No). This field maps to the **check** attribute of the **crl** stanza in the **/usr/lib/security/pki/policy.cfg** file.
- The **Default Communications Timeout** field specifies the timeout period in seconds used by the **certadd** and **certlink** commands when requesting certificate information using HTTP (for example, retrieving CRLs). This field maps to the **timeout** attribute of the **comm** stanza in the **/usr/lib/security/pki/policy.cfg** file.

*methods.cfg* file:

The **methods.cfg** file specifies the definitions of the authentication grammar used by the **registry** and **SYSTEM** attributes. Specifically, this is where the authentication grammar for **PKILDAP** (for PKI using LDAP) and **FPKI** (*files* PKI) must be defined and added by the system administrator.

Below is a typical **methods.cfg** definition. The stanza names **PKI**, **LDAP**, and **PKILDAP** are arbitrary names and can be changed by the administrator. This section uses these stanza names throughout for consistency.

```
PKI:
 program = /usr/lib/security/PKI
 options = authonly

LDAP:
 program = /usr/lib/security/LDAP

PKILDAP:
 options = auth=PKI,db=LDAP
```

To support roaming users, use the same **methods.cfg** file stanza names and attribute values across all systems that support roaming users.

### **Administration configuration examples:**

The following examples show typical administration configuration tasks.

#### **Creating a new PKI user account**

To create a new PKI user account, use the **mkuser** command and the appropriate **/usr/lib/security/methods.cfg** stanza name (PKILDAP). Depending on the attribute settings in the **/usr/lib/security/pki/policy.cfg** file, the **mkuser** command can automatically create a certificate for the user. Below is a **mkuser** command example that creates the user account bob:

```
mkuser -R PKILDAP SYSTEM="PKILDAP" registry=PKILDAP bob
```

#### **Converting a non-PKI user account to a PKI user account**

There are two different approaches for converting a non-PKI user account into a PKI user account. The first approach allows the system administrator access to the user's private keystore initially, which might be acceptable in a given environment, but is the quickest way to convert a user. The second way requires interaction between the user and system administrator, which might take more time to setup.

Both examples use the following assumptions:

- **cas.server** and **cas.client** are already installed, configured, and working.
- **PKILDAP** is defined in **methods.cfg** as shown in "methods.cfg file."

### Example 1:

With root authority, the system administrator can perform the following commands for user account bob:

```
certcreate -f cert1.der -l auth_lb11 cn=bob bob # Create & save cert in cert1.der.
certadd -f cert1.der -l auth_lb11 auth_tag1 bob # Add cert to LDAP as auth_tag1.
certverify auth_tag1 bob # Verify & sign the cert in LDAP.
chuser SYSTEM="PKILDAP" registry=PKILDAP bob # Change account type to PKILDAP.
chuser -R PKILDAP auth_cert=auth_tag1 bob # Set the user's auth certificate.
```

Then, have user bob change his password on the keystore using the **keypasswd** command.

### Example 2:

Have user bob run the first 3 commands of example 1 above (**certcreate**, **certadd**, **certverify**), creating his own certificate and keystore. Then have the system administrator perform the last two **chuser** commands of example 1 above.

### Creating and adding an authentication certificate

If a PKI user requires a new authentication certificate, the user can create a new certificate and have the system administrator make it the user's authentication certificate. Below is an example of user bob creating a certificate and the system administrator making the certificate the authentication certificate.

```
Logged in as user account bob:
certcreate -f cert1.der -l auth_lb11 cn=bob # Create & save cert in cert1.der.
certadd -f cert1.der -l auth_lb11 auth_tag1 # Add cert to LDAP as auth_tag1.
certverify auth_tag1 # Verify & sign the cert in LDAP.
As the system administrator:
chuser -R PKILDAP auth_cert=auth_tag1 bob # Set the user's auth certificate.
```

### Changing the default new-keystore password

Edit the **passwd** attribute value of the newuser stanza in the **/usr/lib/security/pki/policy.cfg** file to modify the password used to create the keystores of new PKI users.

### Handling a compromised trusted signing key

The file that contains the trusted signing key needs to be replaced and the user authentication certificates need to be re-signed.

### Handling a compromised user private key

If a user's private key is compromised, the user or the administrator should revoke the certificate using the appropriate reason code, other users that use the public key should be notified of the compromise and, depending on the purpose of the private/public key, a new certificate should be issued. If the certificate was used as the user's authentication certificate, then another certificate (either the new certificate or an existing non-compromised certificate owned by the user) should be added as the new authentication certificate.

### Handling a compromised keystore or keystore password

Change the password on the keystore. Revoke all the user's certificates. Create new certificates for the user including a new authentication certificate. The compromised private keys may still be useful to the user for accessing previously encrypted data.

### Moving a user's keystore or changing the name of a user's keystore

Every user certificate maintained in LDAP contains the keystore location of its matching private key. To move a user's keystore from one directory to another or to change the name of the keystore, requires

changing the LDAP keystore location and name associated with the user's certificates. If the user uses multiple keystores, then extra care must be taken to change only the LDAP information of the certificates affected by the keystore change.

To move a keystore from `/var/pki/security/keys/user1.p12` to `/var/pki/security1/keys/user1.p12`:

```
As root...

cp /var/pki/security/keys/user1.p12 /var/pki/security1/keys/user1.p12

Retrieve a list of all the certificates associated with the user.
certlist ALL user1

For each certificate associated with the keystore, do the following:
A) Retrieve the certificate's private key label and its "verified" status.
B) Retrieve the certificate from LDAP.
C) Replace the certificate in LDAP using the same private key label,
but the new keystore path name.
D) If the certificate was previously verified, it must be verified again.
(Step D requires the password to the keystore.)

Example modifying one certificate.
Assume:

username: user1

cert tag: tag1

key label: label1

Retrieve the certificate's private key label.
certlist -a label tag1 user1

Retrieve the certificate from LDAP and place it in file cert.der.
certget -f cert.der tag1 user1

Replace the certificate in LDAP.
certadd -r -f cert.der -p /var/pki/security1/keys/user1.p12 -l label1 tag1 user1

Re-verify the certificate if it was previously verified.
(Need to know the keystore password.)
certverify tag1 user1
```

### ***Adding a certificate issued by a non-AIX Certificate Authority:***

You must have possession of the certificate and private key before adding this certificate into AIX for login purposes. Certificate Authentication Services filesets must be installed and configured.

The certificate must be a DER-encoded x509 v3 certificate and the keystore must be a pkcs12 type keystore. In the following example, the name of the certificate file is **aixtest.cer**, the name of the private key file is **aixtest.p12**, and the name of the AIX user is **aixuser**. The user **aixuser** must already exist on the system. The key label is **aixtest** and keystore password is secret.

The size of the key in the keystore might not be supported by the underlying crypto provider. In that case you might need to get the proper Java security policy files to remove the restrictions.

Perform these steps to use a certificate issued by another Certificate Authority (CA) for login:

1. Verify that the keystore is compatible by listing the keystore using the `/usr/bin/keylist` command.

```
keylist -v -p aixtest.p12
Enter password for the keystore :
Private Key : aixtest
Certificate : aixtest
#
```

The **keytool** command also displays the contents of the keystore. An error from the **keytool** command might be an indication of lack of key size support by the underlying crypto provider.

```
keytool -list -keystore aixtest.p12 -storepass secret -storetype pkcs12
```

```
Keystore type: pkcs12
Keystore provider: IBMJCE
```

Your keystore contains 1 entry

2. Add the private key into the AIX keystore by using the **keyadd** command. The keys are stored in the user's default keystore. If the keystore does not exist, a new one is created. Remember the password of the keystore as you will need it during login.

```
keyadd -l aixtest -s aixtest.p12 aixuser
Enter password for the source keystore :
Enter password for the destination keystore :
Re-enter password for the destination keystore :
#
```

Verify that the key is added by specifying the AIX user name:

```
keylist -v aixuser
Enter password for the keystore :
Private Key : aixtest
Certificate : aixtest
#
```

3. Add the certificate to AIX LDAP certificate repository:

```
certadd -c -f aixtest.cer -l aixtest logincert aixuser
```

Verify that the certificate is added to the repository:

```
certlist -f logincert aixuser
aixuser:
 auth_cert=
 distinguished_name=c=US,o=IBM,ou=Sec Team,cn=AIX test
 alternate_name=
 validafter=0412230006
 validuntil=1231215916
 issuer=c=US,o=IBM,ou=Sec Team,cn=AIX test
 tag=logincert
 verified=false
```

4. Verify that the user's private key matches the certificate:

```
certverify logincert puser1
Enter password for the keystore :
```

Check that verification is successful:

```
certlist -f -a verified logincert aixuser
aixuser:
 verified=true
```

5. Set the user's authentication certificate:

```
chuser -R PKIfiles auth_cert=logincert aixuser
```

Verify that the **auth\_cert** attribute is set correctly:

```
lsuser -R PKIfiles -a auth_cert aixuser
```

```
aixuser auth_cert=logincert
```

6. Set the **SYSTEM** and **registry** attributes:

```
chuser -R PKIfiles SYSTEM=PKIfiles registry=PKIfiles aixuser
```

Verify that the attributes are set:

```
lsuser -f -R PKIfiles -a SYSTEM registry auth_cert aixuser
aixuser:
 SYSTEM=PKIfiles
 registry=PKIfiles
 auth_cert=logincert
```



7. Add an entry into the **ca.cfg** file corresponding to the non-AIX CA. Specify the certificate issuer's distinguished name in the **dn** field and the program name in the **program** field. Use the **certlist** command to get the distinguished name of the CA that issued the certificate.

```
certlist -f -a issuer logincert aixuser
aixuser:
 issuer=c=US,o=IBM,ou=Sec Team,cn=AIX test
```

```
#
```

Specify the program name as **/usr/lib/security/pki/JSML.sml**.

Edit the **/usr/lib/security/pki/ca.cfg** file to add the above information:

```
remoteCA:
 program = /usr/lib/security/pki/JSML.sml
 dn = "c=US,o=IBM,ou=Sec Team,cn=AIX test"
```

```
telnet testsystem.ibm.com
AIX Version 5
(C) Copyrights by IBM and by others 1982, 2006.
login: aixuser
aixuser's Password:
```

8. Verify that **aixuser** can login to the system using this certificate:

```
telnet testsystem.ibm.com
AIX Version 5
(C) Copyrights by IBM and by others 1982, 2006.
login: aixuser
aixuser's Password:
```

```
.....
```

```
Last login: Fri Apr 14 10:46:29 CDT 2006 on /dev/pts/3 from localhost
```

```
$ echo $AUTHSTATE
PKIfiles
$
```

## Pluggable Authentication Modules

The pluggable authentication module (PAM) framework provides system administrators with the ability to incorporate multiple authentication mechanisms into an existing system through the use of pluggable modules.

Applications enabled to make use of PAM can be *plugged-in* to new technologies without modifying the existing applications. This flexibility allows administrators to do the following:

- Select any authentication service on the system for an application
- Use multiple authentication mechanisms for a given service
- Add new authentication service modules without modifying existing applications
- Use a previously entered password for authentication with multiple modules

The PAM framework consists of a library, pluggable modules, and a configuration file. The PAM library implements the PAM application programming interface (API) and serves to manage PAM transactions and invoke the PAM service programming interface (SPI) defined in the pluggable modules. Pluggable modules are dynamically loaded by the library based on the invoking service and its entry in the configuration file. Success is determined not only by the pluggable module but also by the behavior defined for the service. Through the concept of *stacking*, a service can be configured to authenticate through multiple authentication methods. If supported, modules can also be configured to use a previously submitted password rather than prompting for additional input.

The system administrator can configure an AIX system to use PAM through modification of the **auth\_type** attribute in the **usw** stanza of the **/etc/security/login.cfg** file. Setting **auth\_type = PAM\_AUTH** configures

PAM-enabled commands to invoke the PAM API directly for authentication rather than use the historic AIX authentication routines. This configuration is a run-time decision and does not require a reboot of the system to take affect. For further information about the **auth\_type** attribute, see the **/etc/security/login.cfg** file reference. The following native AIX commands and applications have been modified to recognize the **auth\_type** attribute and enabled for PAM authentication:

- **login**
- **passwd**
- **su**
- **ftp**
- **telnet**
- **rlogin**
- **rexec**
- **rsh**
- **snappd**
- **imapd**
- **dtaction**
- **dtlogin**
- **dtsession**

The following illustration shows the interaction between PAM-enabled applications, PAM library, configuration file, and PAM modules on a system that has been configured to use PAM. PAM enabled applications invoke the PAM API in the PAM library. The library determines the appropriate module to load based on the application entry in the configuration file and calls the PAM SPI in the module. Communication occurs between the PAM module and the application through the use of a conversation function implemented in the application. Success or failure from the module and the behavior defined in the configuration file then determine if another application module needs to be loaded. If so, the process continues; otherwise, the result is passed back to the application.

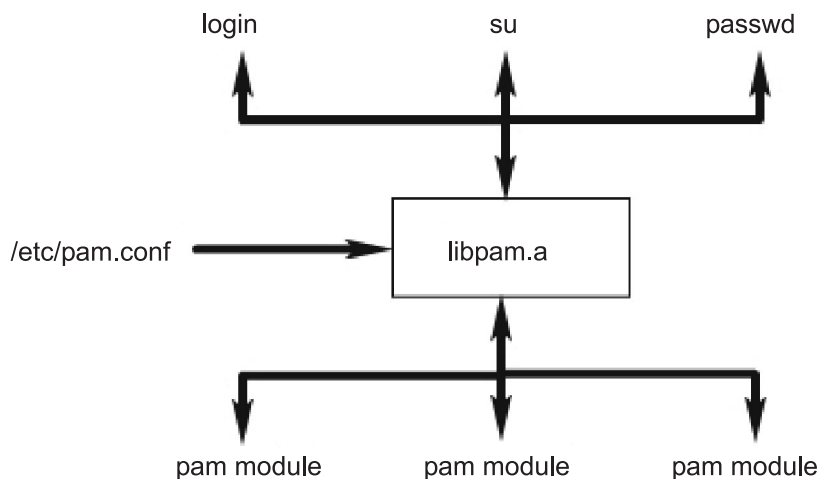

*Figure 3. PAM Framework and Entities. This illustration shows how PAM enabled commands use the PAM library to access the appropriate PAM module.*

### **PAM library**

The PAM library, **/usr/lib/libpam.a**, contains the PAM API that serves as a common interface to all PAM applications and also controls module loading.

Modules are loaded by the PAM library based on the stacking behavior defined in the **/etc/pam.conf** file.

The following PAM API functions invoke the corresponding PAM SPI provided by a PAM module. For example, the pam\_authenticate API invokes the pam\_sm\_authenticate SPI in a PAM module.

- pam\_authenticate
- pam\_setcred
- pam\_acct\_mgmt
- pam\_open\_session
- pam\_close\_session
- pam\_chauthtok

The PAM library also includes several framework APIs that enable an application to invoke PAM modules and pass information to PAM modules. The following table shows the PAM framework APIs that are implemented in AIX and their functions:

|                |                                                                                  |
|----------------|----------------------------------------------------------------------------------|
| pam_start      | Establish a PAM session                                                          |
| pam_end        | Terminate a PAM session                                                          |
| pam_get_data   | Retrieve module-specific data                                                    |
| pam_set_data   | Set module-specific data                                                         |
| pam_getenv     | Retrieve the value of a defined PAM environment variable                         |
| pam_getenvlist | Retrieve a list of all of the defined PAM environment variables and their values |
| pam_putenv     | Set a PAM environment variable                                                   |
| pam_get_item   | Retrieve common PAM information                                                  |
| pam_set_item   | Set common PAM information                                                       |
| pam_get_user   | Retrieve user name                                                               |
| pam_strerror   | Get PAM standard error message                                                   |

## PAM modules

PAM modules allow multiple authentication mechanisms to be used collectively or independently on a system.

A given PAM module must implement at least one of four module types. The module types are described as follows, along with the corresponding PAM SPIs that are required to conform to the module type.

### Authentication Modules

Authenticate users and set, refresh, or destroy credentials. These modules identify user based on their authentication and credentials.

Authentication module functions:

- pam\_sm\_authenticate
- pam\_sm\_setcred

### Account Management Modules

Determine validity of the user account and subsequent access after identification from authentication module. Checks performed by these modules typically include account expiration and password restrictions.

Account management module function:

- pam\_sm\_acct\_mgmt

### Session Management Modules

Initiate and terminate user sessions. Additionally, support for session auditing may be provided.

Session management module functions:

- pam\_sm\_open\_session
- pam\_sm\_close\_session

## Password Management Modules

Perform password modification and related attribute management.

Password management module functions:

- pam\_sm\_chauthtok

## PAM configuration file

The `/etc/pam.conf` configuration file consists of service entries for each PAM module type and serves to route services through a defined module path.

Entries in the file are composed of the following whitespace-delimited fields:

```
service_name module_type control_flag module_path module_options
```

Where:

|                       |                                                                                                                                                                                                                                                                                                                                                                                             |
|-----------------------|---------------------------------------------------------------------------------------------------------------------------------------------------------------------------------------------------------------------------------------------------------------------------------------------------------------------------------------------------------------------------------------------|
| <i>service_name</i>   | Specifies the name of the service. The keyword <b>OTHER</b> is used to define the default module to use for applications not specified in an entry.                                                                                                                                                                                                                                         |
| <i>module_type</i>    | Specifies the module type for the service. Valid module types are <b>auth</b> , <b>account</b> , <b>session</b> , or <b>password</b> . A given module will provide support for one or more module types.                                                                                                                                                                                    |
| <i>control_flag</i>   | Specifies the stacking behavior for the module. Supported control flags are required, requisite, sufficient, or optional.                                                                                                                                                                                                                                                                   |
| <i>module_path</i>    | Specifies the module to load for the service. Valid values for <i>module_path</i> may be specified as either the full path to the module or just the module name. If the full path to the module is not specified, then the PAM library will prepend to the module name either <code>/usr/lib/security</code> for 32-bit services or <code>/usr/lib/security/64</code> for 64-bit services. |
| <i>module_options</i> | Specifies a space-delimited list of options that can be passed to the service modules. Values for this field are dependent on the options supported by the module defined in the <i>module_path</i> field. This field is optional.                                                                                                                                                          |

Malformed entries or entries with incorrect values for the **module\_type** or **control\_flag** fields are ignored by the PAM library. Entries beginning with a number sign (#) character at the beginning of the line are also ignored because this denotes a comment.

PAM supports a concept typically referred to as "stacking", allowing multiple mechanisms to be used for each service. Stacking is implemented in the configuration file by creating multiple entries for a service with the same **module\_type** field. The modules are invoked in the order in which they are listed in the file for a given service, with the final result determined by the **control\_flag** field specified for each entry. Valid values for the **control\_flag** field and the corresponding behavior in the stack are as follows:

|            |                                                                                                                                                                                                                                                      |
|------------|------------------------------------------------------------------------------------------------------------------------------------------------------------------------------------------------------------------------------------------------------|
| required   | All required modules in a stack must pass for a successful result. If one or more of the required modules fail, all of the required modules in the stack will be attempted, but the error from the first failed required module is returned.         |
| requisite  | Similar to required except that if a requisite module fails, no further modules in the stack are processed and it immediately returns the first failure code from a required or requisite module.                                                    |
| sufficient | If a module flagged as sufficient succeeds and no previous required or sufficient modules have failed, all remaining modules in the stack are ignored and success is returned.                                                                       |
| optional   | If none of the modules in the stack are required and no sufficient modules have succeeded, then at least one optional module for the service must succeed. If another module in the stack is successful, a failure in an optional module is ignored. |

The following `/etc/pam.conf` subset is an example of stacking in the **auth** module type for the login service.

```

#
PAM configuration file /etc/pam.conf
#

Authentication Management
login auth required /usr/lib/security/pam_ckfile file=/etc/nologin
login auth required /usr/lib/security/pam_aix
login auth optional /usr/lib/security/pam_test use_first_pass
OTHER auth required /usr/lib/security/pam_prohibit

```

The example of configuration file contains three entries for the login service. Having specified both **pam\_ckfile** and **pam\_aix** as required, both modules will be run and both must be successful for the overall result to be successful. The third entry for the fictitious **pam\_test** module is optional and its success or failure will not affect whether the user is able to login. The option **use\_first\_pass** to the **pam\_test** module requires that a previously entered password be used instead of prompting for a new one.

Use of the OTHER keyword as a service name enables a default to be set for any other services that are not explicitly declared in the configuration file. Setting up a default ensures that all cases for a given module type will be covered by at least one module. In the case of this example, all services other than login will always fail since the **pam\_prohibit** module returns a PAM failure for all invocations.

### pam\_aix module

The **pam\_aix** module is a PAM module that provides PAM-enabled applications access to AIX security services by providing interfaces that call the equivalent AIX services where they exist.

These services are in turn performed by a loadable authentication module or the AIX built-in function based on the user's definition and the corresponding setup in the **methods.cfg** file. Any error codes generated during execution of an AIX service are mapped to the corresponding PAM error code.

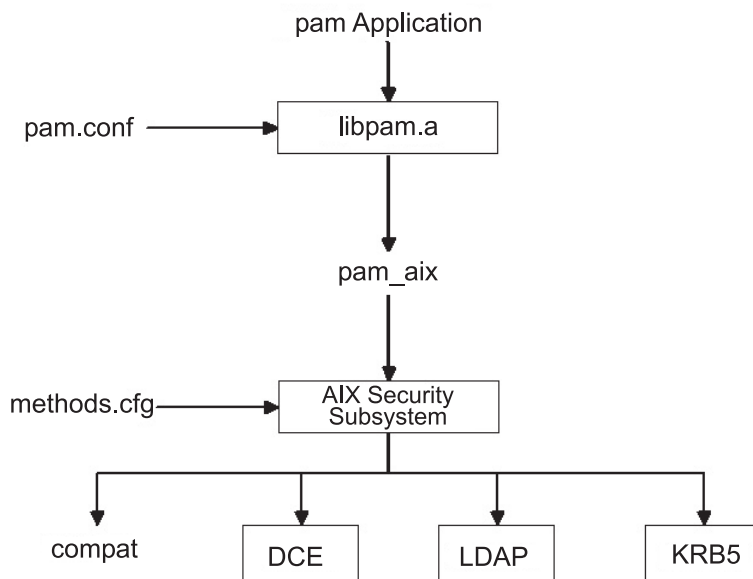

Figure 4. PAM Application to AIX Security Subsystem Path

This illustration shows the path that a PAM application API call will follow if the **/etc/pam.conf** file is configured to make use of the **pam\_aix** module. As shown in the diagram, the integration allows users to be authenticated by any of the loadable authentication modules (DCE, LDAP, or KRB5) or in AIX files (compat).

The **pam\_aid** module is installed in the **/usr/lib/security** directory. Integration of the **pam\_aid** module requires that the **/etc/pam.conf** file be configured to make use of the module. Stacking is still available but is not shown in the following example of the **/etc/pam.conf** file:

```
#
Authentication management
#
OTHER auth required /usr/lib/security/pam_aid

#
Account management
#
OTHER account required /usr/lib/security/pam_aid

#
Session management
#
OTHER session required /usr/lib/security/pam_aid

#
Password management
#
OTHER password required /usr/lib/security/pam_aid
```

The **pam\_aid** module has implementations for the **pam\_sm\_authenticate**, **pam\_sm\_chauthok** and **pam\_sm\_acct\_mgmt** SPI functions. The **pam\_sm\_setcred**, **pam\_sm\_open\_session**, and **pam\_sm\_close\_session** SPI are also implemented in the **pam\_aid** module, but these SPI functions return **PAM\_SUCCESS** invocations.

The following is an approximate mapping of PAM SPI calls to the AIX security subsystem:

| PAM SPI                     | AIX                                                                                                                                       |
|-----------------------------|-------------------------------------------------------------------------------------------------------------------------------------------|
| =====                       | =====                                                                                                                                     |
| <b>pam_sm_authenticate</b>  | --> <b>authenticate</b>                                                                                                                   |
| <b>pam_sm_chauthok</b>      | --> <b>passwdexpired, chpass</b><br>Note: <b>passwdexpired</b> is only checked if the <b>PAM_CHANGE_EXPIRED_AUTHOK</b> flag is passed in. |
| <b>pam_sm_acct_mgmt</b>     | --> <b>loginrestrictions, passwdexpired</b>                                                                                               |
| <b>pam_sm_setcred</b>       | --> No comparable mapping exists, <b>PAM_SUCCESS</b> returned                                                                             |
| <b>pam_sm_open_session</b>  | --> No comparable mapping exists, <b>PAM_SUCCESS</b> returned                                                                             |
| <b>pam_sm_close_session</b> | --> No comparable mapping exists, <b>PAM_SUCCESS</b> returned                                                                             |

Data intended to be passed to the AIX security subsystem can be set using either the **pam\_set\_item** function prior to module use, or the **pam\_aid** module for data if it does not already exist.

## PAM loadable authentication module

AIX security services can be configured to call PAM modules through the use of the existing AIX loadable authentication module framework.

**Note:** Prior to AIX 5.3 a loadable authentication module PAM was used to provide PAM authentication to native AIX applications. Due to differences in behavior between this solution and a true PAM solution, the PAM loadable authentication module is no longer the recommended means to provide PAM authentication to native AIX applications. Instead, the **auth\_type** attribute in the **usw** stanza of **/etc/security/login.cfg** should be set to **PAM\_AUTH** to enable PAM authentication in AIX. For more information on the **auth\_type** attribute, see **/etc/security/login.cfg**. Use of the PAM loadable authentication module is still supported, but it is deprecated. You should use the **auth\_type** attribute to enable PAM authentication.

When the **/usr/lib/security/methods.cfg** file is set up correctly, the PAM load module routes AIX security services (**passwd**, **login**, and so on) to the PAM library. The PAM library checks the **/etc/pam.conf** file to determine which PAM module to use and then makes the corresponding PAM SPI call. Return values from

PAM are mapped to AIX error codes and returned to the calling program. This illustration shows the path that an AIX security service call takes when PAM is configured correctly.

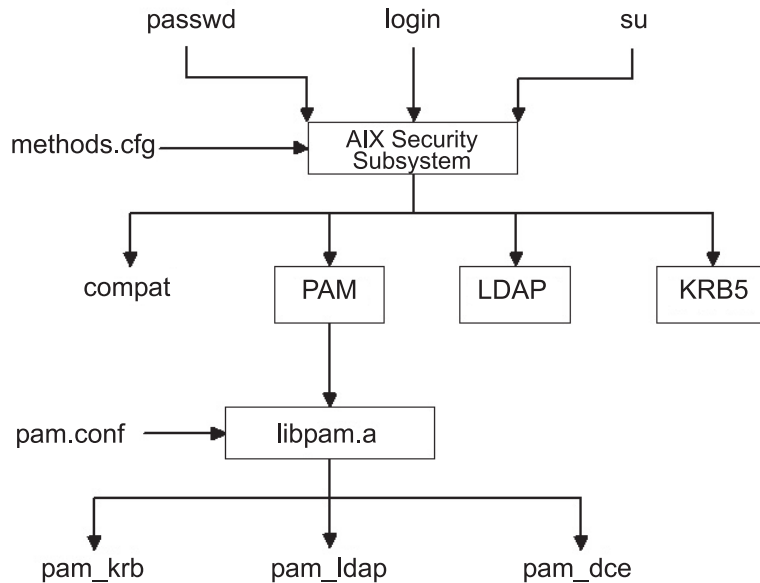

Figure 5. AIX Security Service to PAM Module Path

The PAM modules shown (pam\_krb, pam\_ldap, and pam\_dce) are listed as examples of third-party solutions.

The PAM load module is installed in the **/usr/lib/security** directory and is an authentication-only module. The PAM module must be combined with a database to form a compound load module. The following example shows the stanzas that could be added to the **methods.cfg** file to form a compound PAM module with a database called files. The BUILTIN keyword for the **db** attribute designates the database as UNIX files.

```

PAM:
 program = /usr/lib/security/PAM

PAMfiles:
 options = auth=PAM,db=BUILTIN

```

Creating and modifying users is then performed by using the **-R** option with the administration commands and by setting the **SYSTEM** attribute when a user is created. For example:

```
mkuser -R PAMfiles SYSTEM=PAMfiles registry=PAMfiles pamuser
```

This action informs further calls to AIX security services (login, passwd, and so on) to use the PAM load module for authentication. While the **files** database was used for the compound module in this example, other databases, such as LDAP, can also be used if they are installed. Creating users as previously described will result in the following mapping of AIX security to PAM API calls:

| AIX                | PAM API                                            |
|--------------------|----------------------------------------------------|
| =====              | =====                                              |
| authenticate       | --> pam_authenticate                               |
| chpass             | --> pam_chauthtok                                  |
| passwdexpired      | --> pam_acct_mgmt                                  |
| passwdrestrictions | --> No comparable mapping exists, success returned |

Customizing the **/etc/pam.conf** file allows the PAM API calls to be directed to the desired PAM module for authentication. To further refine the authentication mechanism, stacking can be implemented.

Data prompted for by an AIX security service is passed to PAM through the `pam_set_item` function because it is not possible to accommodate user dialog from PAM. PAM modules written for integration with the PAM module should retrieve all data with `pam_get_item` calls and should not attempt to prompt the user to input data because this is handled by the security service.

Loop detection is provided to catch possible configuration errors in which an AIX security service is routed to PAM and then a PAM module in turn attempts to call the AIX security service to perform the operation. Detection of this loop event will result in an immediate failure of the intended operation.

**Note:** The `/etc/pam.conf` file should *not* be written to make use of the `pam_aix` module when using PAM integration from an AIX security service to a PAM module because this will result in a loop condition.

## Adding a PAM module

You can add a PAM module to enable multiple authentication mechanisms.

1. Place the 32-bit version of the module in the `/usr/lib/security` directory and the 64-bit version of the module in `/usr/lib/security/64` directory.
2. Set file ownership to root and permissions to 555. The PAM library does not load any module not owned by the root user.
3. Update the `/etc/pam.conf` configuration file to include the module in entries for the desired service names.
4. Test the affected services to ensure their functionality. Do not log off the system until a login test has been performed.

## Changing the `/etc/pam.conf` file

There are a few things you should consider before changing the `/etc/pam.conf` file.

When changing the `/etc/pam.conf` configuration file, consider the following requirements:

- The file should always be owned by the root user and group security. Permission on the file needs to be 644 to allow everyone read access but only allow root to modify.
- For greater security, consider explicitly configuring each PAM-enabled service and then using the `pam_prohibit` module for the OTHER service keyword.
- Read any documentation supplied for a chosen module, and determine which control flags and options are supported and what their impact will be.
- Select the ordering of modules and control flags carefully, keeping in mind the behavior of required, requisite, sufficient, and optional control flags in stacked modules.

**Note:** Incorrect configuration of the PAM configuration file can result in a system that cannot be logged in to since the configuration applies to all users including root. After making changes to the file, always test the affected applications before logging out of the system. A system that cannot be logged in to can be recovered by booting the system in maintenance mode and correcting the `/etc/pam.conf` configuration file.

## Enabling PAM debug

The PAM library can provide debug information during execution. After enabling the system to collect debug output, the information gathered can be used to track PAM-API invocations and determine failure points in the current PAM setup.

To enable PAM debug output, perform these steps:

1. Create an empty file at `/etc/pam_debug`. The PAM library checks for existence of the `/etc/pam_debug` file and if found, enables syslog output.
2. Edit the `/etc/syslog.conf` file to contain the appropriate entries for the desired levels of messages.
3. Restart the `syslogd` daemon so that configuration changes are recognized.



4. When the PAM application is restarted, debug messages will be collected in the output file defined in the `/etc/syslog.conf` configuration file.

## OpenSSH software tools

OpenSSH software tools support the SSH1 and SSH2 protocols. The tools provide shell functions where network traffic is encrypted and authenticated.

OpenSSH is based on client and server architecture. OpenSSH runs the **sshd** daemon process on the AIX host and waits for the connection from clients. It supports public-key and private-key pairs for authentication and encryption of channels to ensure secure network connections and host-based authentication. For more information about OpenSSH, including the man pages, see the following Web sites:

<http://www.openssh.org>

[http://www-128.ibm.com/developerworks/eserver/articles/openssh\\_updated.html](http://www-128.ibm.com/developerworks/eserver/articles/openssh_updated.html)

To download the latest **installp** format packages for AIX go to the following Web site:  
<http://sourceforge.net/projects/openssh-aix>.

This section explains how to install and configure OpenSSH on AIX.

The OpenSSH software is shipped on the AIX 5.3 Expansion Pack. This version of OpenSSH is compiled and packaged as installp packages using the openssh-3.8.p1 level of source code. The installp packages include the man pages and the translated message files. The OpenSSH program contained in the Expansion Pack CD-ROM media is licensed under the terms and conditions of the IBM International Program License Agreement (IPLA) for Non-Warranted Programs.

Before installing the OpenSSH installp format packages, you must install the Open Secure Sockets Layer (OpenSSL) software that contains the encrypted library. OpenSSL is available in RPM packages on the AIX Toolbox for Linux Applications CD, or you can also download the packages from the following AIX Toolbox for Linux Applications Web site:

<http://www-1.ibm.com/servers/aix/products/aixos/linux/download.html>

Because the OpenSSL package contains cryptographic content, you must register on the Web site to download the packages. You can download the packages by completing the following steps:

1. Click the AIX Toolbox Cryptographic Content link on the right side of the AIX Toolbox for Linux Applications Web site.
2. Click I have not registered before.
3. Fill in the required fields in the form.
4. Read the license and then click **Accept License**. The browser automatically redirects to the download page.
5. Scroll down the list of cryptographic content packages until you see **openssl-0.9.6m-1.aix4.3.ppc.rpm** under OpenSSL — SSL Cryptographic Libraries.
6. Click the **Download Now!** button for the **openssl-0.9.6m-1.aix4.3.ppc.rpm**.

After you download the OpenSSL package, you can install OpenSSL and OpenSSH.

1. Install the OpenSSL RPM package using the **geninstall** command:

```
geninstall -d/dev/cd0 R:openssl-0.9.6m
```

Output similar to the following displays:

```
SUCCESSES

openssl-0.9.6m-3
```

2. Install the OpenSSH installp packages using the **geninstall** command:

```
geninstall -I"Y" -d/dev/cd0 I:openssh.base
```

Use the **Y** flag to accept the OpenSSH license agreement after you have reviewed the license agreement.

Output similar to the following displays:

Installation Summary

-----

| Name                | Level      | Part | Event | Result  |
|---------------------|------------|------|-------|---------|
| openssh.base.client | 3.8.0.5200 | USR  | APPLY | SUCCESS |
| openssh.base.server | 3.8.0.5200 | USR  | APPLY | SUCCESS |
| openssh.base.client | 3.8.0.5200 | ROOT | APPLY | SUCCESS |
| openssh.base.server | 3.8.0.5200 | ROOT | APPLY | SUCCESS |

You can also use the SMIT **install\_software** fast path to install OpenSSL and OpenSSH.

The following OpenSSH binary files are installed as a result of the preceding procedure:

**scp** File copy program similar to rcp

**sftp** Program similar to FTP that works over SSH1 and SSH2 protocol

**sftp-server**

SFTP server subsystem (started automatically by sshd daemon)

**ssh** Similar to the rlogin and rsh client programs

**ssh-add**

Tool that adds keys to ssh-agent

**ssh-agent**

An agent that can store private keys

**ssh-keygen**

Key generation tool

**ssh-keyscan**

Utility for gathering public host keys from a number of hosts

**ssh-keysign**

Utility for host-based authentication

**ssh-rand-helper**

A program used by OpenSSH to gather random numbers. It is used only on AIX 5.1 installations.

**sshd** Daemon that permits you to log in

The following general information covers OpenSSH:

- The **/etc/ssh** directory contains the **sshd** daemon and the configuration files for the **ssh** client command.
- The **/usr/openssh** directory contains the readme file and the original OpenSSH open-source license text file. This directory also contains the **ssh** protocol and Kerberos license text.
- The **sshd** daemon is under AIX SRC control. You can start, stop, and view the status of the daemon by issuing the following commands:

```
startsrc -s sshd OR startsrc -g ssh (group)
stopsrc -s sshd OR stopsrc -g ssh
lssrc -s sshd OR lssrc -s ssh
```

You can also start and stop the daemon by issuing the following commands:

```
/etc/rc.d/rc2.d/Ksshd start
```

OR

```
/etc/rc.d/rc2.d/Ssshd start
/etc/rc.d/rc2.d/Ksshd stop
```

OR

```
/etc/rc.d/rc2.d/Ssshd stop
```

- When the OpenSSH server fileset is installed, an entry is added to the **/etc/rc.d/rc2.d** directory. An entry is in inittab to start run-level 2 processes (12:2:wait:/etc/rc.d/rc 2), so the **sshd** daemon will start automatically at boot time. To prevent the daemon from starting at boot time, remove the **/etc/rc.d/rc2.d/Ksshd** and **/etc/rc.d/rc2.d/Ssshd** files.
- OpenSSH software logs information to SYSLOG.
- The IBM Redbooks® publication, *Managing AIX Server Farms*, provides information about configuring OpenSSH in AIX and is available at the following Web site:  
<http://www.redbooks.ibm.com>
- OpenSSH supports long user names (256 bytes), the same as the AIX base operating system. For more information on long user names, see the **mkuser** command.
- Some keywords, such as AllowUsers, DenyUsers, AllowGroups, and DenyGroups are not available by default in the **ssh\_config** file or the **sshd\_config** file. You must add these keywords to the configuration files in order to use them.

## OpenSSH images

Use the following steps to install the OpenSSH images:

1. Download the images from <http://sourceforge.net/projects/openssh-aix>
2. Decompress the image package using the **uncompress** *packagename* command. For example:  

```
uncompress openssh361p2_52_nologin.tar.Z
```
3. Untar the package with the **tar -xvf** *packagename* command. For example:  

```
tar -xvf openssh361p2_52_nologin.tar
```
4. Run **inutoc**.
5. Run **smitty install**.
6. Select **Install and Update Software**.
7. Select **Update Installed Software to Latest Level (Update All)**.
8. Type a dot (.) in the field for **INPUT device / directory for software** and press Enter.
9. Scroll down to **ACCEPT new license agreements** and press the **Tab** key to change the field to **Yes**.
10. Press the Enter key twice to start the installation.

The OpenSSH images are base level images, not Program Temporary Fixes (PTFs). Upon installation, all of the previous version's code is overwritten with the new version's images.

## Configuration of OpenSSH compilation

The following information discusses how the OpenSSH code is compiled for AIX.

When configuring OpenSSH for AIX 5.1, the output is similar to the following:

```
OpenSSH has been configured with the following options:
 User binaries: /usr/bin
 System binaries: /usr/sbin
 Configuration files: /etc/ssh
 Askpass program: /usr/sbin/ssh-askpass
 Manual pages: /usr/man
 PID file: /etc/ssh
Privilege separation chroot path: /var/empty
ssh default user PATH: /usr/bin:/bin:/usr/sbin:/sbin:/usr/local/bin

 Manpage format: man
 PAM support: no
 KerberosIV support: no
```

```

 KerberosV support: yes
 Smartcard support: no
 AFS support: no
 S/KEY support: no
 TCP Wrappers support: no
 MD5 password support: no
 IP address in $DISPLAY hack: no
 Use IPv4 by default hack: no
 Translate v4 in v6 hack: no
 BSD Auth support: no
 Random number source: ssh-rand-helper
 ssh-rand-helper collects from: Command hashing (timeout 200)

```

```

 Host: powerpc-ibm-aix5.1.0.0
 Compiler: cc
 Compiler flags: -O -D_STR31__
 Preprocessor flags: -I. -I$(srcdir) -I/home/BUILD/test2debug/zlib-1.1.3/ -I/opt/freeware/src/packages/SOURCES/openssl-0.9.6m/include -I/usr/include -I/usr/include/gssapi -I/usr/include/ibm_svc -I/usr/local/include $(PATHS) -DHAVE_CONFIG_H
 Linker flags: -L. -Lopenbsd-compat/ -L/opt/freeware/lib/ -L/usr/local/lib -L/usr/krb5/lib -blibpath:/opt/freeware/lib:/usr/lib:/lib:/usr/local/lib:/usr/krb5/lib
 Libraries: -lz -lcrypto -lkrb5 -lk5crypto -lcom_err

```

WARNING: you are using the builtin random number collection service. Please read WARNING.RNG and request that your OS vendor includes kernel-based random number collection in future versions of your OS.

When configuring OpenSSH for AIX 5.2 the output is similar to the following:

OpenSSH has been configured with the following options:

```

 User binaries: /usr/bin
 System binaries: /usr/sbin
 Configuration files: /etc/ssh
 Askpass program: /usr/sbin/ssh-askpass
 Manual pages: /usr/man
 PID file: /etc/ssh
 Privilege separation chroot path: /var/empty
 sshd default user PATH: /usr/bin:/bin:/usr/sbin:/sbin:/usr/local/bin

```

```

 Manpage format: man
 PAM support: no
 KerberosIV support: no
 KerberosV support: yes
 Smartcard support: no
 AFS support: no
 S/KEY support: no
 TCP Wrappers support: no
 MD5 password support: no
 IP address in $DISPLAY hack: no
 Use IPv4 by default hack: no
 Translate v4 in v6 hack: no
 BSD Auth support: no
 Random number source: OpenSSL internal ONLY

```

```

 Host: powerpc-ibm-aix5.2.0.0
 Compiler: cc
 Compiler flags: -O -D_STR31__
 Preprocessor flags: -I/opt/freeware/src/packages/BUILD/openssl-0.9.6m/include -I/usr/local/include -I/usr/local/include
 Linker flags: -L/opt/freeware/src/packages/BUILD/openssl-0.9.6m -L/usr/local/lib -L/usr/local/lib -blibpath:/usr/lib:/lib:/usr/local/lib:/usr/local/lib
 Libraries: -lz -lcrypto -lkrb5 -lk5crypto -lcom_err

```

When configuring OpenSSH for AIX 5.3 the output is similar to the following:

OpenSSH has been configured with the following options:

```

 User binaries: /usr/bin
 System binaries: /usr/sbin
 Configuration files: /etc/ssh

```

```

 Askpass program: /usr/sbin/ssh-askpass
 Manual pages: /usr/man
 PID file: /etc/ssh
Privilege separation chroot path: /var/empty
 sshd default user PATH: /usr/bin:/bin:/usr/sbin:/sbin:/usr/
 local/bin

 Manpage format: man
 KerberosIV support: no
 KerberosV support: yes
 Smartcard support: no
 AFS support: no
 S/KEY support: no
 TCP Wrappers support: no
 MD5 password support: no
 IP address in $DISPLAY hack: no
 Use IPv4 by default hack: no
 Translate v4 in v6 hack: no
 BSD Auth support: no
 Random number source: OpenSSL internal ONLY

 Host: powerpc-ibm-aix5.3.0.0
 Compiler: cc
 Compiler flags: -O -D__STR31__
 Preprocessor flags: -I/opt/freeware/src/packages/BUILD/openssl-0.9.6m/

include -I/usr/local/include -I/usr/local/include
 Linker flags: -L/opt/freeware/src/packages/BUILD/openssl-0.9.6m
 -L/usr/local/lib -L/usr/local/lib -blibpath:/usr/lib:/lib:/usr/local/
 lib:/usr/local/lib
 Libraries: -lz -lcrypto -lkrb5 -lk5crypto -lcom_err

```

## OpenSSH and Kerberos Version 5 support

Kerberos is an authentication mechanism that provides a secure means of authentication for network users. It prevents transmission of clear text passwords over the network by encrypting authentication messages between clients and servers. In addition, Kerberos provides a system for authorization in the form of administering tokens, or credentials.

To authenticate a user using Kerberos, the user runs the **init** command to gain initial credentials from a central Kerberos server known as the KDC (Key Distribution Center). The KDC verifies the user and passes back to the user his initial credentials, known as a TGT (Ticket-Granting Ticket). The user can then start a remote login session using a service such as a Kerberized Telnet or OpenSSH, and Kerberos authenticates the user by gaining user credentials from the KDC. Kerberos performs this authentication without any need for user interaction, therefore users do not need to enter passwords to login. IBM's version of Kerberos is known as Network Authentication Service (NAS). NAS can be installed from the AIX Expansion Pack CDs. It is available in the **krb5.client.rte** and **krb5.server.rte** packages. Beginning in the July 2003 release of OpenSSH 3.6, OpenSSH supports Kerberos 5 authentication and authorization through NAS version 1.3.

OpenSSH version 3.8 and later supports Kerberos 5 authentication and authorization through NAS Version 1.4. Any migration from previous versions of NAS (Kerberos) needs to happen before updating OpenSSH. OpenSSH version 3.8.x will only work with NAS version 1.4 or later.

AIX has created OpenSSH with Kerberos authentication as an optional method. If the Kerberos libraries are not installed on the system, when OpenSSH runs Kerberos authentication is skipped and OpenSSH tries the next configured authentication method (such as AIX authentication).

After you install Kerberos, it is recommended that you read the Kerberos documentation before configuring the Kerberos servers. For more information about how to install and administer Kerberos, refer to the *IBM Network Authentication Service Version 1.3 for AIX : Administrator's and User's Guide* located in the **/usr/lpp/krb5/doc/html/lang/ADMININGD.htm** path.

### **Using OpenSSH with Kerberos:**

Some initial setup is required to use OpenSSH with Kerberos.

The following steps provide information on the initial setup that is required in order to use OpenSSH with Kerberos:

1. On your OpenSSH clients and servers, the **/etc/krb5.conf** file must exist. This file tells Kerberos which KDC to use, how long of a lifetime to give each ticket, and so on. The following is an example **krb5.conf** file:

```
[libdefaults]
ticket_lifetime = 600
default_realm = OPENSSEH.AUSTIN.XYZ.COM
default_tkt_enctypes = des3-hmac-sha1 des-cbc-crc
default_tgs_enctypes = des3-hmac-sha1 des-cbc-crc

[realms]
OPENSSEH.AUSTIN.xyz.COM = {
 kdc = kerberos.austin.xyz.com:88
 kdc = kerberos-1.austin.xyz.com:88
 kdc = kerberos-2.austin.xyz.com:88
 admin_server = kerberos.austin.xyz.com:749
 default_domain = austin.xyz.com
}

[domain_realm]
.austin.xyz.com = OPENSSEH.AUSTIN.XYZ.COM
kdc.austin.xyz.com = OPENSSEH.AUSTIN.XYZ.COM
```

2. Also, you must add the following Kerberos services to each client machine's **/etc/services** file:

```
kerberos 88/udp kdc # Kerberos V5 KDC
kerberos 88/tcp kdc # Kerberos V5 KDC
kerberos-adm 749/tcp # Kerberos 5 admin/changepw
kerberos-adm 749/udp # Kerberos 5 admin/changepw
krb5_prop 754/tcp # Kerberos slave
 # propagation
```

3. If your KDC is using LDAP as the registry to store user information, read “LDAP authentication load module” on page 131, and the Kerberos publications. Furthermore, make sure the following actions are performed:

- KDC is running the LDAP client. You can start the LDAP client daemon with the **secldapclntd** command.
- LDAP server is running the **slapd** LDAP server daemon.

4. On the OpenSSH server, edit the **/etc/ssh/sshd\_config** file to contain the lines:

```
KerberosAuthentication yes
KerberosTicketCleanup yes
GSSAPIAuthentication yes
GSSAPICleanupCredentials yes
UseDNS yes
```

If UseDNS is set to **Yes**, the ssh server does a reverse host lookup to find the name of the connecting client. This is necessary when host-based authentication is used or when you want last login information to display host names rather than IP addresses.

**Note:** Some ssh sessions stall when performing reverse name lookups because the DNS servers are unreachable. If this happens, you can skip the DNS lookups by setting UseDNS to no. If UseDNS is not explicitly set in the **/etc/ssh/sshd\_config** file, the default value is UseDNS yes.

5. On the SSH server, run the **startsrc -g ssh** command to start the ssh server daemon.
6. On the SSH client machine, run the **kinit** command to gain initial credentials (a TGT). You can verify that you received a TGT by running the **klist** command. This shows all credentials belonging to you.
7. Connect to the server by running the **ssh username@servername** command.

8. If Kerberos is properly configured to authenticate the user, a prompt for a password will not display, and the user will be automatically logged into the SSH server.

---

## Securing the network

The following sections describe how to install and configure IP Security; how to identify necessary and unnecessary network services; and auditing and monitoring network security.

### TCP/IP security

If you installed the Transmission Control Protocol/Internet Protocol (TCP/IP) and Network File System (NFS) software, you can configure your system to communicate over a network.

This guide does not describe the basic concepts of TCP/IP, but rather describes security-related concerns of TCP/IP. For information on installing and the initial configuration of TCP/IP, refer to the Transmission Control Protocol/Internet Protocol section in *Networks and communication management*.

For any number of reasons, the person who administers your system might have to meet a certain level of security. For instance, the security level might be a matter of corporate policy. Or a system might need access to government systems and thus be required to communicate at a certain security level. These security standards might be applied to the network, the operating system, application software, even programs written by the person who administers your system.

This section describes the security features provided with TCP/IP, both in standard mode and as a secure system, and discusses some security considerations that are appropriate in a network environment.

After you install TCP/IP and NFS software, use the Web-based System Manager or the System Management Interface Tool (SMIT) **tcpip** fast path, to configure your system.

For more information on the **dacinet** command, refer to the *AIX Version 6.1 Commands Reference*.

### Operating system-specific security

Many of the security features, such as network access control and network auditing, available for TCP/IP are based on those available through the operating system.

The following sections outline TCP/IP security.

#### **Network access control:**

The security policy for networking is an extension of the security policy for the operating system and consists of user authentication, connection authentication, and data security.

It consists of the following major components:

- User authentication is provided at the remote host by a user name and password in the same way as when a user logs in to the local system. Trusted TCP/IP commands, such as **ftp**, **rexec**, and **telnet**, have the same requirements and undergo the same verification process as trusted commands in the operating system.
- Connection authentication is provided to ensure that the remote host has the expected Internet Protocol (IP) address and name. This prevents a remote host from masquerading as another remote host.
- Data import and export security permits data at a specified security level to flow to and from network interface adapters at the same security and authority levels. For example, top-secret data can flow only between adapters that are set to the top-secret security level.

#### **Network auditing:**

Network auditing is provided by TCP/IP, using the audit subsystem to audit both kernel network routines and application programs.

The purpose of auditing is to record those actions that affect the security of the system and the user responsible for those actions.

The following types of events are audited:

#### **Kernel events**

- Change configuration
- Change host ID
- Change route
- Connection
- Create socket
- Export object
- Import object

#### **Application events**

- Access the network
- Change configuration
- Change host ID
- Change static route
- Configure mail
- Connection
- Export data
- Import data
- Write mail to a file

Creation and deletion of objects are audited by the operating system. Application audit records suspend and resume auditing to avoid redundant auditing by the kernel.

#### ***Trusted path, trusted shell, and Secure Attention Key:***

The operating system provides the *trusted path* to prevent unauthorized programs from reading data from a user terminal. This path is used when a secure communication path with the system is required, such as when you are changing passwords or logging in to the system.

The operating system also provides the *trusted shell (tsh)*, which runs only trusted programs that have been tested and verified as secure. TCP/IP supports both of these features, along with the *secure attention key (SAK)*, which establishes the environment necessary for secure communication between you and the system. The local SAK is available whenever you are using TCP/IP. A remote SAK is available through the **telnet** command.

The local SAK has the same function in **telnet** that it has in other operating system application programs: it ends the **telnet** process and all other processes associated with the terminal in which **telnet** was running. Inside the telnet program, however, you can send a request for a trusted path to the remote system using the **telnet send sak** command (while in **telnet** command mode). You can also define a single key to initiate the SAK request using the **telnet set sak** command.

For more information about the Trusted Computing Base, see “Trusted Computing Base” on page 1.



## TCP/IP command security

Some commands in TCP/IP provide a secure environment during operation. These commands are **ftp**, **rexec**, and **telnet**.

The **ftp** function provides security during file transfer. The **rexec** command provides a secure environment for running commands on a foreign host. The **telnet** function provides security for login to a foreign host.

The **ftp**, **rexec**, and **telnet** commands provide security during their operation only. That is, they do not set up a secure environment for use with other commands. For securing your system for other operations, use the **securetcPIP** command. This command gives you the ability to secure your system by disabling the nontrusted daemons and applications, and by giving you the option of securing your IP layer network protocol as well.

The **ftp**, **rexec**, **securetcPIP**, and **telnet** commands provide the following forms of system and data security:

### **ftp**

The **ftp** command provides a secure environment for transferring files. When a user invokes the **ftp** command to a foreign host, the user is prompted for a login ID. A default login ID is shown: the user's current login ID on the local host. The user is prompted for a password for the remote host.

The automatic login process searches the local user's **\$HOME/.netrc** file for the user's ID and password to use at the foreign host. For security, the permissions on the **\$HOME/.netrc** file must be set to 600 (read and write by owner only). Otherwise, automatic login fails.

**Note:** Because use of the **.netrc** file requires storage of passwords in a nonencrypted file, the automatic login feature of the **ftp** command is not available when your system has been configured with the **securetcPIP** command. This feature can be reenabled by removing the **ftp** command from the tcPIP stanza in the **/etc/security/config** file.

To use the file transfer function, the **ftp** command requires two TCP/IP connections, one for the File Transfer Protocol (FTP) and one for data transfer. The protocol connection is primary and is secure because it is established on reliable communicating ports. The secondary connection is needed for the actual transfer of data, and both the local and remote host verify that the other end of this connection is established with the same host as the primary connection. If the primary and secondary connections are not established with the same host, the **ftp** command first displays an error message stating that the data connection was not authenticated, and then it exits. This verification of the secondary connection prevents a third host from intercepting data intended for another host.

### **rexec**

The **rexec** command provides a secure environment for executing commands on a foreign host. The user is prompted for both a login ID and a password.

An automatic login feature causes the **rexec** command to search the local user's **\$HOME/.netrc** file for the user's ID and password on a foreign host. For security, the permissions on the **\$HOME/.netrc** file must be set to 600 (read and write by owner only). Otherwise, automatic login fails.

**Note:** Because use of the **.netrc** file requires storage of passwords in a nonencrypted file, the automatic login feature of **rexec** command is not available when your system is operating in secure. This feature can be reenabled by removing the entry from the tcPIP stanza in the **/etc/security/config** file.

## securetcip

The **securetcip** command enables TCP/IP security features. Access to commands that are not trusted is removed from the system when this command is issued. Each of the following commands is removed by running the **securetcip** command:

- **rlogin** and **rlogind**
- **rcp**, **rsh**, and **rshd**
- **tftp** and **tftpd**
- **trpt**

The **securetcip** command is used to convert a system from the standard level of security to a higher security level. After your system has been converted, you need not issue the **securetcip** command again unless you reinstall TCP/IP.

## telnet or tn

The **telnet** (TELNET) command provides a secure environment for login to a foreign host. The user is prompted for both a login ID and a password. The user's terminal is treated just like a terminal connected directly to the host. That is, access to the terminal is controlled by permission bits. Other users (group and other) do not have read access to the terminal, but they can write messages to it if the owner gives them write permission. The **telnet** command also provides access to a trusted shell on the remote system through the SAK. This key sequence differs from the sequence that invokes the local trusted path and can be defined within the **telnet** command.

### **Remote command execution access:**

Users on the hosts listed in the **/etc/hosts.equiv** file can run certain commands on your system without supplying a password.

The following table provides information about how to list, add, and remove remote hosts using Web-based System Manager, SMIT, or command line.

Table 12. Remote command execution access tasks

| Task                                                 | SMIT fast path                       | Command or file                                   | Web-based System Manager Management Environment                                                                                                                                                                                                                                                                                                                                                       |
|------------------------------------------------------|--------------------------------------|---------------------------------------------------|-------------------------------------------------------------------------------------------------------------------------------------------------------------------------------------------------------------------------------------------------------------------------------------------------------------------------------------------------------------------------------------------------------|
| List Remote Hosts That Have Command Execution Access | <b>smit</b><br><b>lshostsequiv</b>   | view<br><b>/etc/hosts.equiv</b> file              | <b>Software</b> → <b>Network</b> → <b>TCPIP (IPv4 and IPv6)</b> → <b>TCPIP Protocol Configuration</b> → <b>TCP/IP</b> → <b>Configure TCP/IP</b> → <b>Advanced Methods</b> → <b>Hosts File</b> → <b>Contents of /etc/hosts file</b>                                                                                                                                                                    |
| Add a Remote Host for Command Execution Access       | <b>smit</b><br><b>mksmhostsequiv</b> | edit <b>/etc/hosts.equiv</b> file <sup>note</sup> | <b>Software</b> → <b>Network</b> → <b>TCPIP (IPv4 and IPv6)</b> → <b>TCPIP Protocol Configuration</b> → <b>TCP/IP</b> → <b>Configure TCP/IP</b> → <b>Advanced Methods</b> → <b>Hosts File</b> . In <b>Add/Change host entry</b> , complete the following fields: <b>IP Address</b> , <b>Host name</b> , <b>Alias(es)</b> , and <b>Comment</b> . Click <b>Add/Change Entry</b> , and click <b>OK</b> . |
| Remove a Remote Host from Command Execution Access   | <b>smit</b><br><b>rmsmhostsequiv</b> | edit <b>/etc/hosts.equiv</b> file <sup>note</sup> | <b>Software</b> → <b>Network</b> → <b>TCPIP (IPv4 and IPv6)</b> → <b>TCPIP Protocol Configuration</b> → <b>TCP/IP</b> → <b>Configure TCP/IP</b> → <b>Advanced Methods</b> → <b>Hosts File</b> . Select a host in <b>Contents of /etc/host file</b> . Click <b>Delete Entry</b> → <b>OK</b> .                                                                                                          |

**Note:** For more information about these file procedures, see the "hosts.equiv File Format for TCP/IP" in the *AIX Version 6.1 Files Reference*.

**Restricted file transfer program users:**

Users listed in the **/etc/ftpusers** file are protected from remote FTP access. For example, suppose that user A is logged into a remote system, and he knows the password of user B on your system. If user B is listed in the **/etc/ftpusers** file, user A cannot FTP files to or from user B's account, even though user A knows user B's password.

The following table provides information about how to list, add, and remove restricted users using Web-based System Manager, SMIT, or command line.

*Remote FTP user tasks*

| Task                      | SMIT fast path         | Command or file                                | Web-based System Manager Management Environment                                                                |
|---------------------------|------------------------|------------------------------------------------|----------------------------------------------------------------------------------------------------------------|
| List Restricted FTP Users | <b>smit lsftpusers</b> | view <b>/etc/ftpusers</b> file                 | <b>Software → Users → All Users.</b>                                                                           |
| Add a Restricted User     | <b>smit mkftpusers</b> | edit <b>/etc/ftpusers</b> file <sup>Note</sup> | <b>Software → Users → All Users → Selected → Add this User to Group.</b> Select a group, and click <b>OK</b> . |
| Remove a Restricted User  | <b>smit rmftpusers</b> | edit <b>/etc/ftpusers</b> file <sup>Note</sup> | <b>Software → Users → All Users → Selected → Delete.</b>                                                       |

**Note:** For more information about these file procedures, see the "ftpusers File Format for TCP/IP" in the *AIX Version 6.1 Files Reference*.

**Trusted processes**

A trusted program, or trusted process, is a shell script, a daemon, or a program that meets a particular standard of security. These security standards are set and maintained by the U.S. Department of Defense, which also certifies some trusted programs.

Trusted programs are trusted at different levels. Security levels include A1, B1, B2, B3, C1, C2, and D, with level A1 providing the highest security level. Each security level must meet certain requirements. For example, the C2 level of security incorporates the following standards:

- program integrity** Ensures that the process performs exactly as intended.
- modularity** Process source code is separated into modules that cannot be directly affected or accessed by other modules.
- principle of least privilege** States that at all times a user is operating at the lowest level of privilege authorized. That is, if a user has access only to view a certain file, then the user does not inadvertently also have access to alter that file.
- limitation of object reuse** Keeps a user from, for example, accidentally finding a section of memory that has been flagged for overwriting but not yet cleared, and which might contain sensitive material.

TCP/IP contains several trusted daemons and many nontrusted daemons.

Examples of trusted daemons are as follows:

- **ftpd**
- **rexecd**
- **telnetd**

Examples of nontrusted daemons are as follows:

- rshd
- rlogind
- tftpd

For a system to be trusted, it must operate with a trusted computing base; that is, for a single host, the machine must be secure. For a network, all file servers, gateways, and other hosts must be secure.

## Network Trusted Computing Base

The Network Trusted Computing Base (NTCB) consists of hardware and software for ensuring network security. This section defines the components of the NTCB as they relate to TCP/IP.

The hardware security features for the network are provided by the network adapters used with TCP/IP. These adapters control incoming data by receiving only data destined for the local system and broadcast data receivable by all systems.

The software component of the NTCB consists of only those programs that are considered as trusted. The programs and associated files that are part of a secure system are listed in the following tables on a directory-by-directory basis.

*/etc directory*

| Name        | Owner | Group  | Mode | Permissions |
|-------------|-------|--------|------|-------------|
| gated.conf  | root  | system | 0664 | rw-rw-r—    |
| gateways    | root  | system | 0664 | rw-rw-r—    |
| hosts       | root  | system | 0664 | rw-rw-r—    |
| hosts.equiv | root  | system | 0664 | rw-rw-r—    |
| inetd.conf  | root  | system | 0644 | rw-r—r—     |
| named.conf  | root  | system | 0644 | rw-r—r—     |
| named.data  | root  | system | 0664 | rw-rw-r—    |
| networks    | root  | system | 0664 | rw-rw-r—    |
| protocols   | root  | system | 0644 | rw-r—r—     |
| rc.tcpip    | root  | system | 0774 | rwXrwxr—    |
| resolv.conf | root  | system | 0644 | rw-rw-r—    |
| services    | root  | system | 0644 | rw-r—r—     |
| 3270.keys   | root  | system | 0664 | rw-rw-r—    |
| 3270keys.rt | root  | system | 0664 | rw-rw-r—    |

*/usr/bin directory*

| Name     | Owner | Group  | Mode | Permissions |
|----------|-------|--------|------|-------------|
| host     | root  | system | 4555 | r-sr-Xr-X   |
| hostid   | bin   | bin    | 0555 | r-Xr-Xr-X   |
| hostname | bin   | bin    | 0555 | r-Xr-Xr-X   |
| finger   | root  | system | 0755 | rwXr-Xr-X   |
| ftp      | root  | system | 4555 | r-sr-Xr-X   |
| netstat  | root  | bin    | 4555 | r-sr-Xr-X   |
| rexec    | root  | bin    | 4555 | r-sr-Xr-X   |
| ruptime  | root  | system | 4555 | r-sr-Xr-X   |
| rwho     | root  | system | 4555 | r-sr-Xr-X   |

*/usr/bin directory*

| Name   | Owner | Group  | Mode | Permissions |
|--------|-------|--------|------|-------------|
| talk   | bin   | bin    | 0555 | r-xr-xr-x   |
| telnet | root  | system | 4555 | r-sr-xr-x   |

*/usr/sbin directory*

| Name       | Owner | Group  | Mode | Permissions |
|------------|-------|--------|------|-------------|
| arp        | root  | system | 4555 | r-sr-xr-x   |
| fingerd    | root  | system | 0554 | r-xr-xr---  |
| ftpd       | root  | system | 4554 | r-sr-xr---  |
| gated      | root  | system | 4554 | r-sr-xr---  |
| ifconfig   | bin   | bin    | 0555 | r-xr-xr-x   |
| inetd      | root  | system | 4554 | r-sr-xr---  |
| named      | root  | system | 4554 | r-sr-x---   |
| ping       | root  | system | 4555 | r-sr-xr-x   |
| rexecd     | root  | system | 4554 | r-sr-xr---  |
| route      | root  | system | 4554 | r-sr-xr---  |
| routed     | root  | system | 0554 | r-xr-x---   |
| rwhod      | root  | system | 4554 | r-sr-xr---  |
| securetcip | root  | system | 0554 | r-xr-xr---  |
| setclock   | root  | system | 4555 | r-sr-xr-x   |
| syslogd    | root  | system | 0554 | r-xr-xr---  |
| talkd      | root  | system | 4554 | r-sr-xr---  |
| telnetd    | root  | system | 4554 | r-sr-xr---  |

*/usr/ucb directory*

| Name | Owner | Group  | Mode | Permissions |
|------|-------|--------|------|-------------|
| tn   | root  | system | 4555 | r-sr-xr-x   |

*/var/spool/rwho directory*

| Name             | Owner | Group  | Mode | Permissions |
|------------------|-------|--------|------|-------------|
| rwho (directory) | root  | system | 0755 | drwxr-xr-x  |

## Data security and information protection

The security feature for TCP/IP does not encrypt user data transmitted through the network.

Identify any risk in communication that could result in the disclosure of passwords and other sensitive information, and based on that risk, apply appropriate countermeasures.

Using the TCP/IP security feature in a Department of Defense (DOD) environment might require adherence to DOD 5200.5 and NCSD-11 for communications security.

## User based TCP port access control with discretionary access control for internet ports

Discretionary Access Control for Internet Ports (DACinet) features user-based access control for TCP ports for communication between AIX 5.2 hosts.

AIX 5.2 can use an additional TCP header to transport user and group information between systems. The DACinet feature allows the administrator on the destination system to control access based on the destination port, the originating user id and host.

**Note:** The DACinet facility is available only in CAPP/EAL4+ configured AIX systems.

In addition, the DACinet feature allows the administrator to restrict local ports for root only usage. UNIX systems like AIX treat ports below 1024 as privileged ports which can only be opened by root. AIX 5.2 allows you to specify additional ports above 1024 which can be opened only by root, therefore preventing users from running servers on well known ports.

Depending on the settings a non-DACinet system may or may not be able to connect to a DACinet system. Access is denied in the initial state of the DACinet feature. Once DACinet has been enabled, there is no way to disable DACinet.

The **dacinet** command accepts addresses which are specified as hostnames, dotted decimal host addresses, or network addresses followed by the length of the network prefix.

The following example specifies a single host which is known by the fully qualified host name *host.domain.org*:

```
host.domain.org
```

The following example specifies a single host which is known by the IP address 10.0.0.1:

```
10.0.0.1
```

The following example specifies the entire network which has the first 24 bits (the length of the network prefix) with a value of 10.0.0.0:

```
10.0.0.0/24
```

This network includes all IP addresses between 10.0.0.1 and 10.0.0.254.

### **Access control for TCP based services:**

DACinet uses the **/etc/rc.dacinet** startup file, and the configuration files it uses are **/etc/security/priv**, **/etc/security/services**, and **/etc/security/acl**.

Ports listed in **/etc/security/services** are considered exempt from the ACL checks. The file has the same format as **/etc/services**. The easiest way to initialize it is to copy the file from **/etc** to **/etc/security** and then delete all the ports for which ACLs should be applied. The ACLs are stored in two places. The currently active ACLs are stored in the kernel and can be read by running **dacinet accls**. ACLs that will be reactivated at the next system boot by **/etc/rc.tcpip** are stored in **/etc/security/acl**. The following format is used:

```
service host/prefix-length [user|group]
```

Where the service can be specified either numerically or as listed in **/etc/services**, the host can be given either as a host name or a network address with a subnet mask specification and the user or group is specified with the u: or g: prefix. When no user or group is specified, then the ACL takes only the sending host into account. Prefixing the service with a - will disable access explicitly. ACLs are evaluated according to the first match. So you could specify access for a group of users, but explicitly deny it for a user in the group by placing the rule for this user in front of the group rule.

The **/etc/services** file includes two entries with port number values which are not supported in AIX 5.2. The system administrator must remove both lines from that file prior to executing the **mkCCadmin** command. Remove the following lines from the **/etc/services** file:

```
sco_printer 70000/tcp sco_spooler # For System V print IPC
sco_s5_port 70001/tcp lpNet_s5_port # For future use
```

#### *DACinet usage examples:*

For example, when using DACinet to restrict access to port TCP/25 inbound to root only with the DACinet feature, then only root users from other AIX 5.2 hosts can access this port, therefore limiting the possibilities of regular users to spoof e-mail by just telneting to port TCP/25 on the victim.

The following example shows how to configure the X protocol (X11) for root only access. Make sure that the X11 entry in **/etc/security/services** is removed, so that the ACLs will apply for this service.

Assuming a subnet of 10.1.1.0/24 for all the connected systems, the ACL entries to restrict access to the root user only for X (TCP/6000) in **/etc/security/acl** would be as follows:

```
6000 10.1.1.0/24 u:root
```

When limiting Telnet service to users in the group friends, no matter from which system they are coming from, use the following ACL entry after having removed the telnet entry from **/etc/security/services**:

```
telnet 0.0.0.0/0 g:friends
```

Disallow user fred access to the web server, but allow everyone else access:

```
-80 0.0.0.0/0 u:fred
80 0.0.0.0/0
```

#### ***Privileged ports for running local services:***

To prevent regular users from running servers at specific ports, these ports can be designated as privileged.

Normally any user can open any port above 1024. For example, a user could place a server at port 8080, which is quite often used to run Web proxies or at 1080 where one typically finds a SOCKS server. The **dacinet setpriv** command can be used to add privileged ports to the running system. Ports that are to be designated as privileged when the system starts have to be listed in **/etc/security/priv**.

Ports can be listed in this file either with their symbolic name as defined in **/etc/services** or by specifying the port number. The following entries would disallow non-root users to run SOCKS servers or Lotus Notes® servers on their usual ports:

```
1080
lotusnote
```

**Note:** This feature does not prevent the user from running the programs. It will only prevent the user from running the services at the well known ports where those services are typically expected.

## **Network services**

Information about identifying and securing network services with open communication ports is shown.

### **Ports usage**

The following table describes known port usage on AIX.

**Note:** This list has been established by reviewing multiple AIX systems with different configurations of software installed.

The following list might not include port usage for all software existing on AIX:

| Port/Protocol | ServiceName | Aliases                   |
|---------------|-------------|---------------------------|
| 13/tcp        | daytime     | Daytime (RFC 867)         |
| 13/udp        | daytime     | Daytime (RFC 867)         |
| 21/tcp        | ftp         | File Transfer [Control]   |
| 21/udp        | ftp         | File Transfer [Control]   |
| 23/udp        | telnet      | Telnet                    |
| 23/udp        | telnet      | Telnet                    |
| 25/tcp        | smtp        | Simple Mail Transfer      |
| 25/udp        | smtp        | Simple Mail Transfer      |
| 37/tcp        | time        | Time                      |
| 37/udp        | time        | Time                      |
| 111/tcp       | sunrpc      | SUN Remote Procedure Call |
| 111/udp       | sunrpc      | SUN Remote Procedure Call |
| 161/tcp       | snmp        | SNMP                      |
| 161/udp       | snmp        | SNMP                      |
| 199/tcp       | smux        | SMUX                      |
| 199/udp       | smux        | SMUX                      |
| 512/tcp       | exec        | remote process execution; |
| 513/tcp       | login       | remote login a la telnet; |
| 514/tcp       | shell       | cmd                       |
| 514/udp       | syslog      | Syslog                    |
| 518/tcp       | ntalk       | Talk                      |
| 518/udp       | ntalk       | Talk                      |
| 657/tcp       | rmc         | RMC                       |
| 657/udp       | rmc         | RMC                       |
| 1334/tcp      | writesrv    | writesrv                  |
| 1334/udp      | writesrv    | writesrv                  |
| 2279/tcp      | xmquery     | xmquery                   |
| 2279/udp      | xmquery     | xmquery                   |
| 9090/tcp      | wsmserver   | WebSM                     |
| 32768/tcp     | filenet-tms | Filenet TMS               |
| 32768/udp     | filenet-tms | Filenet TMS               |
| 32769/tcp     | filenet-rpc | Filenet RPC               |
| 32769/udp     | filenet-rpc | Filenet RPC               |
| 32770/tcp     | filenet-nch | Filenet NCH               |
| 32770/udp     | filenet-nch | Filenet NCH               |
| 32771/tcp     | filenet-rmi | FileNET RMI               |
| 32771/udp     | filenet-rmi | FileNet RMI               |
| 32772/tcp     | filenet-pa  | FileNET Process Analyzer  |
| 32772/udp     | filenet-pa  | FileNET Process Analyzer  |



| Port/Protocol | ServiceName                     | Aliases                   |
|---------------|---------------------------------|---------------------------|
| 32773/tcp     | filenet-cm                      | FileNET Component Manager |
| 32773/udp     | filenet-cm                      | FileNET Component Manager |
| 32774/tcp     | filenet-re                      | FileNET Rules Engine      |
| 32774/udp     | filenet-re FileNET Rules Engine | FileNET Rules Engine      |

## Identifying network services with open communication ports

Client-server applications open communication ports on the server, allowing the applications to listen to incoming client requests.

Because open ports are vulnerable to potential security attacks, identify which applications have open ports and close those ports that are open unnecessarily. This practice is useful because it allows you to understand what systems are being made available to anyone who has access to the Internet.

To determine which ports are open, follow these steps:

1. Identify the services by using the **netstat** command as follows:

```
netstat -af inet
```

The following is an example of this command output. The last column of the **netstat** command output indicates the state of each service. Services that are waiting for incoming connections are in the LISTEN state.

### Active Internet connection (including servers)

| Proto | Recv-Q | Send-Q | Local Address | Foreign Address | (state) |
|-------|--------|--------|---------------|-----------------|---------|
| tcp4  | 0      | 0      | *.echo        | *.*             | LISTEN  |
| tcp4  | 0      | 0      | *.discard     | *.*             | LISTEN  |
| tcp4  | 0      | 0      | *.daytime     | *.*             | LISTEN  |
| tcp   | 0      | 0      | *.chargen     | *.*             | LISTEN  |
| tcp   | 0      | 0      | *.ftp         | *.*             | LISTEN  |
| tcp4  | 0      | 0      | *.telnet      | *.*             | LISTEN  |
| tcp4  | 0      | 0      | *.smtp        | *.*             | LISTEN  |
| tcp4  | 0      | 0      | *.time        | *.*             | LISTEN  |
| tcp4  | 0      | 0      | *.www         | *.*             | LISTEN  |
| tcp4  | 0      | 0      | *.sunrpc      | *.*             | LISTEN  |
| tcp   | 0      | 0      | *.smux        | *.*             | LISTEN  |
| tcp   | 0      | 0      | *.exec        | *.*             | LISTEN  |
| tcp   | 0      | 0      | *.login       | *.*             | LISTEN  |
| tcp4  | 0      | 0      | *.shell       | *.*             | LISTEN  |
| tcp4  | 0      | 0      | *.klogin      | *.*             | LISTEN  |
| udp4  | 0      | 0      | *.kshell      | *.*             | LISTEN  |
| udp4  | 0      | 0      | *.echo        | *.*             |         |
| udp4  | 0      | 0      | *.discard     | *.*             |         |

**Active Internet connection (including servers)**

| Proto | Recv-Q | Send-Q | Local Address        | Foreign Address (state) |
|-------|--------|--------|----------------------|-------------------------|
| udp4  | 0      | 0      | *.daytime            | *.*                     |
| udp4  | 0      | 0      | *.chargen            | *.*                     |
| udp4  | 0      | 0      | *.time               | *.*                     |
| udp4  | 0      | 0      | *.bootpc             | *.*                     |
| udp4  | 0      | 0      | *.sunrpc             | *.*                     |
| udp4  | 0      | 0      | 255.255.255.255.ntp  | *.*                     |
| udp4  | 0      | 0      | 1.23.123.234.ntp     | *.*                     |
| udp4  | 0      | 0      | localhost.domain.ntp | *.*                     |
| udp4  | 0      | 0      | name.domain..ntp     | *.*                     |

.....

2. Open the **/etc/services** file and check the Internet Assigned Numbers Authority (IANA) services to map the service to port numbers within the operating system.

The following is a sample fragment of the **/etc/services** file:

```
tcpmux 1/tcp # TCP Port Service Multiplexer
tcpmux 1/tcp # TCP Port Service Multiplexer
Compressnet 2/tcp # Management Utility
Compressnet 2/udp # Management Utility
Compressnet 3/tcp # Compression Process
Compressnet 3/udp Compression Process
Echo 7/tcp #
Echo 7/udp #
discard 9/tcp sink null
discard 9/udp sink null
.....
rfe 5002/tcp # Radio Free Ethernet
rfe 5002/udp # Radio Free Ethernet
rmonitor_secure 5145/tcp #
rmonitor_secure 5145/udp #
pad12sim 5236/tcp #
pad12sim 5236/udp #
sub-process 6111/tcp # HP SoftBench Sub-Process Cntl.
sub-process 6111/udp # HP SoftBench Sub-Process Cntl.
xdsxdm 6558/ucp #
```

```

xdsxdm 6558/tcp
afs3-fileserver 7000/tcp # File Server Itself
afs3-fileserver 7000/udp # File Server Itself
af3-callback 7001/tcp # Callbacks to Cache Managers
af3-callback 7001/udp # Callbacks to Cache Managers

```

3. Close the unnecessary ports by removing the running services.

**Note:** Port 657 is used by Resource Monitoring and Control (RMC) for communication between nodes. You cannot block or otherwise restrict this port.

### Identifying TCP and UDP sockets

Use the **lsof** command, a variant of the **netstat -af** command to identify TCP sockets that are in the LISTEN state and idle UDP sockets that are waiting for data to arrive.

For example, to display the TCP sockets in the LISTEN state and the UDP sockets in the IDLE state, run the **lsof** command as follows:

```
lsof -i | egrep "COMMAND|LISTEN|UDP"
```

The output produced is similar to the following:

| Command | PID  | USER | FD | TYPE | DEVICE     | SIZE/OFF | NODE | NAME            |
|---------|------|------|----|------|------------|----------|------|-----------------|
| dtlogin | 2122 | root | 5u | IPv4 | 0x70053c00 | 0t0      | UDP  | *:xdmcp         |
| dtlogin | 2122 | root | 6u | IPv4 | 0x70054adc | 0t0      | TCP  | *:32768(LISTEN) |
| syslogd | 2730 | root | 4u | IPv4 | 0x70053600 | 0t0      | UDP  | *:syslog        |
| X       | 2880 | root | 6u | IPv4 | 0x70054adc | 0t0      | TCP  | *:32768(LISTEN) |
| X       | 2880 | root | 8u | IPv4 | 0x700546dc | 0t0      | TCP  | *:6000(LISTEN)  |
| dtlogin | 3882 | root | 6u | IPv4 | 0x70054adc | 0t0      | TCP  | *:32768(LISTEN) |
| glbd    | 4154 | root | 4u | IPv4 | 0x7003f300 | 0t0      | UDP  | *:32803         |
| glbd    | 4154 | root | 9u | IPv4 | 0x7003f700 | 0t0      | UDP  | *:32805         |
| dtgreet | 4656 | root | 6u | IPv4 | 0x70054adc | 0t0      | TCP  | *:32768(LISTEN) |

After identifying the process ID, you can obtain more information about the program by running the following command:

```
" # ps -fp PID#"
```

The output contains the path to the command name, which you can use to access the program's man page.

## Internet Protocol security

IP Security enables secure communications over the Internet and within company networks by securing data traffic at the IP layer.

### IP security overview

IP security allows individual users or organizations to secure traffic for all applications, without having to make any modifications to the applications. Therefore, the transmission of any data, such as e-mail or application-specific company data, can be made secure.

### ***IP security and the operating system:***

The operating system uses IP Security (IPsec), which is an open, standard security technology developed by the Internet Engineering Task Force (IETF).

IPsec provides cryptography-based protection of all data at the IP layer of the communications stack. No changes are needed for existing applications. IPsec is the industry-standard network-security framework chosen by the IETF for both the IP Version 4 and 6 environments.

IPsec protects your data traffic using the following cryptographic techniques:

#### **Authentication**

Process by which the identity of a host or end point is verified

#### **Integrity Checking**

Process of ensuring that no modifications were made to the data while in transit across the network

#### **Encryption**

Process of ensuring privacy by "hiding" data and private IP addresses while in transit across the network

Authentication algorithms prove the identity of the sender and data integrity by using a cryptographic hash function to process a packet of data (with the fixed IP header fields included) using a secret key to produce a unique digest. On the receiver side, the data is processed using the same function and key. If either the data has been altered or the sender key is not valid, the datagram is discarded.

Encryption uses a cryptographic algorithm to modify and randomize the data using a certain algorithm and key to produce encrypted data known as *cyphertext*. Encryption makes the data unreadable while in transit. After it is received, the data is recovered using the same algorithm and key (with symmetric encryption algorithms). Encryption must occur with authentication to verify the data integrity of the encrypted data.

These basic services are implemented in IPsec by the use of the Encapsulating Security Payload (ESP) and the Authentication Header (AH). ESP provides confidentiality by encrypting the original IP packet, building an ESP header, and putting the cyphertext in the ESP payload.

The AH can be used alone for authentication and integrity-checking if confidentiality is not an issue. With AH, the static fields of the IP header and the data have a hash algorithm applied to compute a keyed digest. The receiver uses its key to compute and compare the digest to make sure the packet is unaltered and the sender's identity is authenticated.

### ***IP security features:***

The following are features of IP Security.

- Supports AES 128-, 192-, and 256-bit algorithms.
- Hardware acceleration with the 10/100 Mbps Ethernet PCI Adapter II.
- AH support using RFC 2402, and ESP support using RFC 2406.
- Manual tunnels can be configured to provide interoperability with other systems that do not support the automatic IKE key refreshment method, and for use of IP Version 6 tunnels.
- Tunnel mode and transport mode of encapsulation for host or gateway tunnels.
- Authentication algorithms of HMAC (Hashed Message Authentication Code) MD5 (Message Digest 5) and HMAC SHA (Secure Hash Algorithm).
- Encryption algorithms include 56-bit Data Encryption Standard (DES) Cipher Block Chaining (CBC) with 64-bit initial vector (IV), Triple DES, DES CBC 4 (32 bit IV), and AES CBC.
- Dual IP Stack Support (IP version 4 and IP version 6).

- Both IP Version 4 and IP Version 6 traffic can be encapsulated and filtered. Because the IP stacks are separate, the IP Security function for each stack can be configured independently.
- Filtering of secure and nonsecure traffic by a variety of IP characteristics such as source and destination IP addresses, interface, protocol, port numbers, and more.
- Automatic filter-rule creation and deletion with most tunnel types.
- Use of host names for the destination address when defining tunnels and filter rules. The host names are converted to IP addresses automatically (as long as DNS is available).
- Logging of IP Security events to **syslog**.
- Use of system traces and statistics for problem determination.
- User-defined default action allows the user to specify whether traffic that does not match defined tunnels should be allowed.

*Internet Key Exchange features:*

The following features are available with Internet Key Exchange for AIX 4.3.3 or later.

- ESP encryption support for Data Encryption Standard (DES), Triple DES, AES, Null encryption; ESP authentication support with HMAC MD5 and HMAC SHA1.
- Support incoming PKCS #7 certificate chains (AIX 5.1 and later).
- Certificate Revocation List support with retrieval using HTTP or LDAP servers.
- Automatic key refreshment with tunnels using IETF Internet Key Exchange (IKE) protocol.
- X.509 Digital Certificate and preshared key support in IKE protocol during key negotiation.
- IKE tunnels can be created using Linux configuration files (AIX 5.1 and later).
- Authentication with preshared keys and X.509 digital signatures.
- Use of main mode (identity protect mode) and aggressive mode.
- Support for Diffie Hellman groups 1, 2, and 5.
- AH support for HMAC MD5 and HMAC SHA1.
- IP Version 4 and Version 6 support.

***Security associations:***

The building block on which secure communications is built is a concept known as a *security association*. Security associations relate a specific set of security parameters to a type of traffic.

With data protected by IP Security, a separate security association exists for each direction and for each header type, AH or ESP. The information contained in the security association includes the IP addresses of the communicating parties, a unique identifier known as the Security Parameters Index (SPI), the algorithms selected for authentication or encryption, the authentication and encryption keys, and the key lifetimes. The following figure shows the security associations between Host A and Host B.

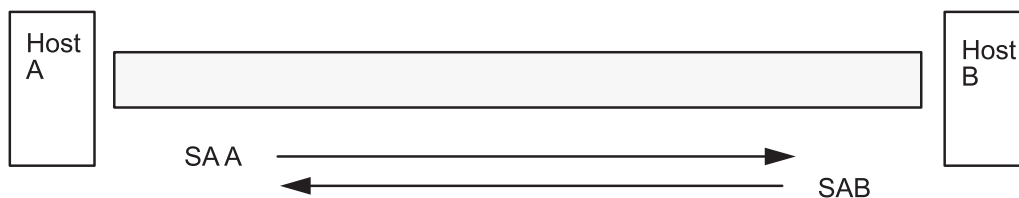

SA = Security Association, consisting of:

- Destination address
- SPI
- Key
- Crypto Algorithm and Format
- Authentication Algorithm
- Key Lifetime

Figure 6. Establishment of a Secure Tunnel Between Hosts A and B

This illustration shows a virtual tunnel running between Host A and Host B. Security association A is an arrow directed from Host A to Host B. Security association B is an arrow directed from Host B to Host A. A Security association consists of the Destination Address, SPI, Key, Crypto Algorithm and Format, Authentication Algorithm, and Key Lifetime.

The goal of key management is to negotiate and compute the security associations that protect IP traffic.

**Tunnels and key management:**

Use a tunnel to negotiate and manage the security associations that are required to set up secure communication between two hosts.

The following types of tunnels are supported, each using a different key management technique:

- IKE tunnels (dynamically changing keys, IETF standard)
- Manual tunnels (static, persistent keys, IETF standard)

*Internet Key Exchange tunnel support:*

IKE Tunnels are based on the Internet Security Association and Key Management Protocol (ISAKMP)/Oakley standards developed by the IETF. With this protocol, security parameters are negotiated and refreshed, and keys are exchanged securely.

The following types of authentication are supported: preshared key and X.509v3 digital certificate signatures.

The negotiation uses a two-phase approach. The first phase authenticates the communicating parties, and specifies the algorithms to be used for securely communicating in phase 2. During phase 2, IP Security parameters to be used during data transfer are negotiated, security associations and keys are created and exchanged.

The following table shows the authentication algorithms that can be used with the AH and ESP security protocols for IKE tunnel support.

| Algorithm | AH IP Version 4 & 6 | ESP IP Version 4 & 6 |
|-----------|---------------------|----------------------|
| HMAC MD5  | X                   | X                    |
| HMAC SHA1 | X                   | X                    |
| DES CBC 8 |                     | X                    |

| Algorithm               | AH IP Version 4 & 6 | ESP IP Version 4 & 6 |
|-------------------------|---------------------|----------------------|
| Triple DES CBC          |                     | X                    |
| AES CBC (128, 192, 256) |                     | X                    |
| ESP Null                |                     | X                    |

*Manual tunnel support:*

Manual tunnels provide backward compatibility, and they interoperate with machines that do not support IKE key management protocols. The disadvantage of manual tunnels is that the key values are static. The encryption and authentication keys are the same for the life of the tunnel and must be manually updated.

The following table shows the authentication algorithms that can be used with the AH and ESP security protocols for manual tunnel support.

| Algorithm               | AH IP Version 4 | AH IP Version 6 | ESP IP Version 4 | ESP IP Version 6 |
|-------------------------|-----------------|-----------------|------------------|------------------|
| HMAC MD5                | X               | X               | X                | X                |
| HMAC SHA1               | X               | X               | X                | X                |
| AES CBC (128, 192, 256) |                 |                 | X                | X                |
| Triple DES CBC          |                 |                 | X                | X                |
| DES CBC 8               |                 |                 | X                | X                |
| DES CBC 4               |                 |                 | X                | X                |

Because IKE tunnels offer more effective security, IKE is the preferred key management method.

***Native filtering capability:***

*Filtering* is a basic function in which incoming and outgoing packets can be accepted or denied based on a variety of characteristics. This allows a user or system administrator to configure the host to control the traffic between this host and other hosts.

Filtering is done on a variety of packet properties, such as source and destination addresses, IP version (4 or 6), subnet masks, protocol, port, routing characteristics, fragmentation, interface, and tunnel definition.

Rules, known as *filter rules*, are used to associate certain kinds of traffic with a particular tunnel. In a basic configuration for manual tunnels, when a user defines a host-to-host tunnel, filter rules are autogenerated to direct all traffic from that host through the secure tunnel. If more specific types of traffic are desired (for instance, subnet to subnet), the filter rules can be edited or replaced to allow precise control of the traffic using a particular tunnel.

For IKE tunnels, the filter rules are also automatically generated and inserted in the filter table once the tunnel is activated.

Similarly, when the tunnel is modified or deleted, the filter rules for that tunnel are automatically deleted, which simplifies IP Security configuration and helps reduce human error. Tunnel definitions can be propagated and shared among machines and firewalls using import and export utilities, which is helpful in the administration of a large number of machines.

Filter rules associate particular types of traffic with a tunnel, but data being filtered does not necessarily need to travel in a tunnel. This aspect of filter rules lets the operating system provide basic firewall

functionality to those who want to restrict traffic to or from their machine in an intranet or in a network that does not have the protection of a true firewall. In this scenario, filter rules provide a second barrier of protection around a group of machines.

After the filter rules are generated, they are stored in a table and loaded into the kernel. When packets are ready to be sent or received from the network, the filter rules are checked in the list from top to bottom to determine whether the packet should be permitted, denied, or sent through a tunnel. The criteria of the rule is compared to the packet characteristics until a match is found or the default rule is reached.

The IP Security function also implements filtering of non-secure packets based on very granular, user-defined criteria, which allows the control of IP traffic between networks and machines that do not require the authentication or encryption properties of IP Security.

### ***Digital certificate support:***

IP Security supports the use of X.509 Version 3 digital certificates.

The Key Manager tool manages certificate requests, maintains the key database, and performs other administrative functions.

Digital certificates are described in Digital Certificate Configuration. The Key Manager and its functions are described in Using the IBM Key Manager Tool

### ***Virtual private networks and IP security:***

A virtual private network (VPN) securely extends a private intranet across a public network such as the Internet.

VPNs convey information across what is essentially a private tunnel through the Internet to and from remote users, branch offices, and business partners/suppliers. Companies can opt for Internet access through Internet service providers (ISPs) using direct lines or local telephone numbers and eliminate more expensive leased lines, long-distance calls, and toll-free telephone numbers. A VPN solution can use the IPsec security standard because IPsec is the IETF-chosen industry standard network security framework for both the IP Version 4 and 6 environments, and no changes are needed for existing applications.

A recommended resource for planning the implementation of a VPN in AIX is Chapter 9 of *A Comprehensive Guide to Virtual Private Networks, Volume III: Cross-Platform Key and Policy Management*, ISBN SG24-5309-00. This guide is also available on the Internet World Wide Web at <http://www.redbooks.ibm.com/redbooks/SG245309.html>.

## **Installing the IP security feature**

The IP Security feature in AIX is separately installable and loadable.

The file sets that need to be installed are as follows:

- **bos.net.ipsec.rte** (The run-time environment for the kernel IP Security environment and commands)
- **bos.msg.LANG.net.ipsec** (where *LANG* is the desired language, such as en\_US)
- **bos.net.ipsec.keymgt**
- **bos.net.ipsec.websm**
- **bos.crypto-priv** (The file set for DES, triple DES and AES encryption)

The **bos.crypto-priv** file set is located on the Expansion Pack. For IKE digital signature support, you must also install the **gskit.rte** fileset (AIX Version 4) or **gskkm.rte** (AIX 5.1) from the Expansion Pack.

For IP Security support in Web-based System Manager, you must install the **Java131.ext.xml4j** fileset at level 1.3.1.1 or later.



After it is installed, IP Security can be separately loaded for IP Version 4 and IP Version 6, either by using the recommended procedure provided in “Loading IP security” or by using the **mkdev** command.

### **Loading IP security:**

Use SMIT or Web-based System Manager to automatically load the IP security modules when IP Security is started. Also, SMIT and Web-based System Manager ensure that the kernel extensions and IKE daemons are loaded in the correct order.

**Note:** Loading IP Security enables the filtering function. Before loading, it is important to ensure the correct filter rules are created. Otherwise, all outside communication might be blocked.

If the loading completes successfully, the **lsdev** command shows the IP Security devices as Available.

```
lsdev -C -c ipsec
```

```
ipsec_v4 Available IP Version 4 Security Extension
ipsec_v6 Available IP Version 6 Security Extension
```

After the IP Security kernel extension has been loaded, tunnels and filters are ready to be configured.

## **Planning IP security configuration**

To configure IP Security, plan to configure the tunnels and filters first.

When a simple tunnel is defined for all traffic to use, the filter rules can be automatically generated. If more complex filtering is desired, filter rules can be configured separately.

You can configure IP Security using the Web-based System Manager Network plug-in, Virtual Private Network plug-in, or the System Management Interface Tool (SMIT). If using SMIT, the following fast paths are available:

### **smit ips4\_basic**

Basic configuration for IP version 4

### **smit ips6\_basic**

Basic configuration for IP version 6

Before configuring IP Security for your site, you must decide what method you intend to use; for example, whether you prefer to use tunnels or filters (or both), which type of tunnel best suits your needs, and so on. The following sections provide information you must understand before making these decisions:

### **Hardware acceleration:**

The 10/100 Mbps Ethernet PCI Adapter II (Feature code 4962) offers standards-based IP Security and is designed to offload IP Security functions from the AIX operating system.

When the 10/100 Mbps Ethernet PCI Adapter II is present in the AIX system, the IP Security stack uses the following capabilities of the adapter:

- Encryption and decryption using DES or Triple DES algorithms
- Authentication using the MD5 or SHA-1 algorithms
- Storage of the security-association information

The functions on the adapter are used instead of the software algorithms. The 10/100 Mbps Ethernet PCI Adapter II is available for manual and IKE tunnels.

The IP Security hardware acceleration feature is available in the 5.1.0.25 or later level of the **bos.net.ipsec.rte** and **devices.pci.1410ff01.rte** file sets.

There is a limit on the number of security associations that can be offloaded to the network adapter on the receive side (inbound traffic). On the transmit side (outbound traffic), all packets that use a supported configuration are offloaded to the adapter. Some tunnel configurations can not be offloaded to the adapter.

The 10/100 Mbps Ethernet PCI Adapter II supports the following features:

- DES, 3DES, or NULL encryption through ESP
- HMAC-MD5 or HMAC-SHA-1 authentication through ESP or AH, but not both. (If ESP and AH both used, ESP must be performed first. This is always true for IKE tunnels, but the user can select the order for manual tunnels.)
- Transport and Tunnel mode
- Offload of IPV4 packets

**Note:** The 10/100 Mbps Ethernet PCI Adapter II cannot handle packets with IP options.

To enable the 10/100 Mbps Ethernet PCI Adapter II for IP Security, you may have to detach the network interface and then enable the IPsec Offload feature.

To detach the network interface, perform the following steps using the SMIT interface:

To enable the IPsec Offload feature, do the following using the SMIT interface:

1. Login as the **root** user.
2. Type `smitty eadap` at the command line and press Enter.
3. Select the **Change / Show Characteristics of an Ethernet Adapter** option and press Enter.
4. Select the 10/100 Mbps Ethernet PCI Adapter II and press Enter.
5. Change the IPsec Offload field to yes and press Enter.

To detach the network interface, from the command line, type the following:

```
ifconfig enX detach
```

To enable the IPsec offload attribute, from the command line, type the following:

```
chdev -l entX -a ipsec_offload=yes
```

To verify that the IPsec offload attribute has been enabled, from the command line, type the following:

```
lsattr -El entX detach
```

To disable the IPsec offload attribute, from the command line, type the following:

```
chdev -l entX -a ipsec_offload=no
```

Use the **entstat** command to ensure that your tunnel configuration is taking advantage of the IPsec offload attribute. The **entstat** command shows all the statistics of transmit and receive IPsec packets when the IPsec offload attribute is enabled. For example, if the Ethernet interface is **ent1**, type the following:

```
entstat -d ent1
```

The output will be similar to the following example:

```
.
. .
10/100 Mbps Ethernet PCI Adapter II (1410ff01) Specific Statistics:

. .
. .
```

Transmit IPsec packets: 3  
Transmit IPsec packets dropped: 0  
Receive IPsec packets: 2  
Receive IPsec packets dropped: 0

### ***Tunnels versus filters:***

Two distinct parts of IP Security are *tunnels* and *filters*. Tunnels require filters, but filters do not require tunnels.

*Filtering* is a function in which incoming and outgoing packets can be accepted or denied based on a variety of characteristics called *rules*. This function allows a system administrator to configure the host to control the traffic between this host and other hosts. Filtering is done on a variety of packet properties, such as source and destination addresses, IP Version (4 or 6), subnet masks, protocol, port, routing characteristics, fragmentation, interface, and tunnel definition. This filtering is done at the IP layer, so no changes are required to the applications.

*Tunnels* define a security association between two hosts. These security associations involve specific security parameters that are shared between end points of the tunnel.

The following illustration indicates how a packet comes in from the network adapter to the IP stack. From there, the filter module is called to determine if the packet is permitted or denied. If a tunnel ID is specified, the packet is checked against the existing tunnel definitions. If the decapsulation from the tunnel is successful, the packet is passed to the upper-layer protocol. This function occurs in reverse order for outgoing packets. The tunnel relies on a filter rule to associate the packet with a particular tunnel, but the filtering function can occur without passing the packet to the tunnel.

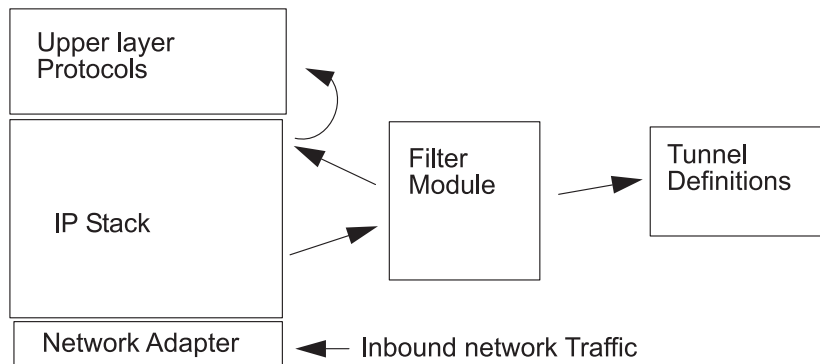

Figure 7. Network Packet Routing

The illustration shows the route a network packet takes. Inbound from the network, the packet enters the network adapter. From there it goes to the IP stack where it is sent to the filter module. From the filter module, the packet is either sent to tunnel definitions or it is returned to the IP stack where it is forwarded to the upper-layer protocols.

### ***Tunnels and security associations:***

Tunnels are used whenever you need to have data authenticated, or authenticated and encrypted. Tunnels are defined by specifying a security association between two hosts. The security association defines the parameters for the encryption and authentication algorithms and characteristics of the tunnel.

The following illustration shows a virtual tunnel between Host A and Host B.

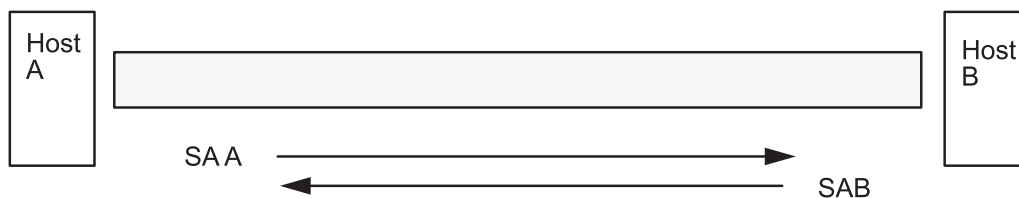

SA = Security Association, consisting of:

- Destination address
- SPI
- Key
- Crypto Algorithm and Format
- Authentication Algorithm
- Key Lifetime

Figure 8. Establishment of a Secure Tunnel Between Hosts A and B

The illustration shows a virtual tunnel running between Host A and Host B. Security association A is an arrow directed from Host A to Host B. Security association B is an arrow directed from Host B to Host A. A security association consists of the Destination Address, SPI, Key, Crypto Algorithm and Format, Authentication Algorithm, and Key Lifetime.

The Security Parameter Index (SPI) and the destination address identify a unique security association. These parameters are required for uniquely specifying a tunnel. Other parameters such as cryptographic algorithm, authentication algorithm, keys, and lifetime can be specified or defaults can be used.

#### **Tunnel considerations:**

You should consider several things before deciding which type of tunnel to use for IP security.

IKE tunnels differ from manual tunnels because the configuration of security policies is a separate process from defining tunnel endpoints.

In IKE, there is a two-step negotiation process. Each step of the negotiation process is called a *phase*, and each phase can have separate security policies.

When the Internet Key negotiation starts, it must set up a secure channel for the negotiations. This is known as the *key management phase* or *phase 1*. During this phase, each party uses preshared keys or digital certificates to authenticate the other and pass ID information. This phase sets up a security association during which the two parties determine how they plan to communicate securely and then which protections are to be used to communicate during the second phase. The result of this phase is an *IKE* or *phase 1* tunnel.

The second phase is known as the *data management phase* or *phase 2* and uses the IKE tunnel to create the security associations for AH and ESP that actually protect traffic. The second phase also determines the data that will be using the IP Security tunnel. For example, it can specify the following:

- A subnet mask
- An address range
- A protocol and port number combination

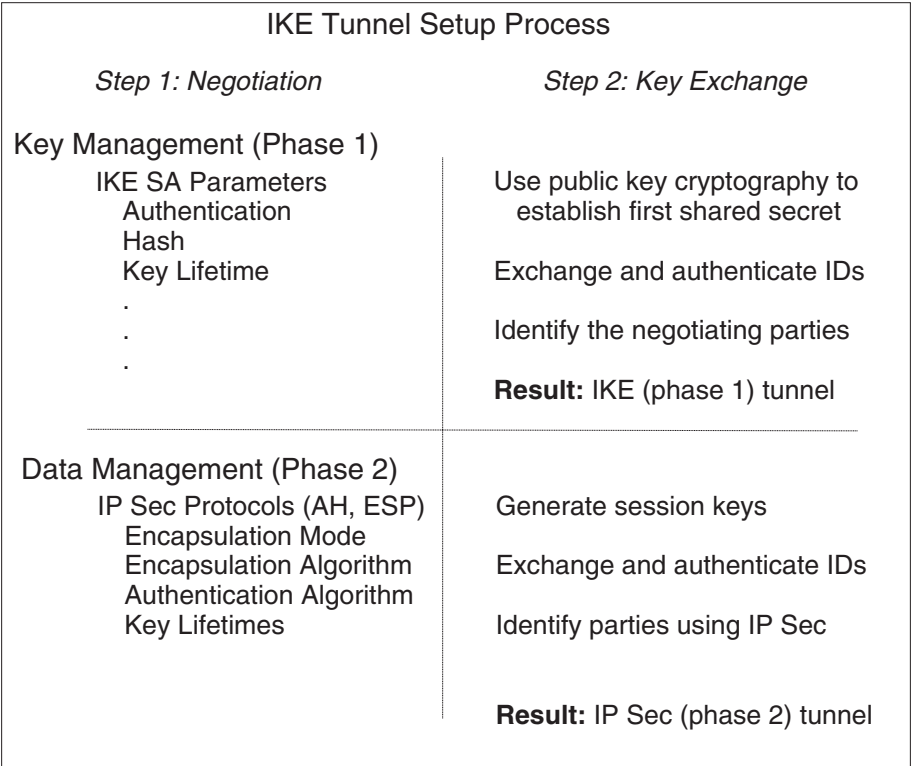

Figure 9. IKE Tunnel Setup Process

This illustration shows the two-step, two-phase process for setting up an IKE tunnel.

In many cases, the endpoints of the key management (IKE) tunnel will be the same as the endpoints of the data management (IP Security) tunnel. The IKE tunnel endpoints are the IDs of the machines carrying out the negotiation. The IP Security tunnel endpoints describe the type of traffic that will use the IP Security tunnel. For simple host-to-host tunnels, in which all traffic between two tunnels is protected with the same tunnel, the phase 1 and phase 2 tunnel endpoints are the same. When negotiating parties are two gateways, the IKE tunnel endpoints are the two gateways, and the IP Security tunnel endpoints are the machines or subnets (behind the gateways) or the range of addresses (behind the gateways) of the tunnel users.

*Key management parameters and policy:*

You can customize key-management policy by specifying the parameters to be used during IKE negotiation. For example, there are key-management policies for pre-shared key or signature mode authentication. For Phase 1, the user must determine certain key-management security properties with which to carry out the exchange.

Phase 1 (the key management phase) sets the following parameters of an IKE tunnel configuration as shown in the table below:

|                                        |                                                                                                                                                                                                                                                                |
|----------------------------------------|----------------------------------------------------------------------------------------------------------------------------------------------------------------------------------------------------------------------------------------------------------------|
| <b>Key Management (Phase 1) Tunnel</b> | Name of this IKE tunnel. For each tunnel, the endpoints of the negotiation must be specified. These are the two machines that plan to send and validate IKE messages. The name of the tunnel may describe the tunnel endpoints such as VPN Boston or VPN Acme. |
|----------------------------------------|----------------------------------------------------------------------------------------------------------------------------------------------------------------------------------------------------------------------------------------------------------------|

|                           |                                                                                                                                                                                                                                                                                                                                                                              |
|---------------------------|------------------------------------------------------------------------------------------------------------------------------------------------------------------------------------------------------------------------------------------------------------------------------------------------------------------------------------------------------------------------------|
| <b>Host Identity Type</b> | ID type that will be used in the IKE exchange. The ID type and value must match the value for the preshared key to ensure that proper key lookup is performed. If a separate ID is used to search a preshared key value, the <i>host ID</i> is the key's ID and its <i>type</i> is KEY_ID. The KEY_ID type is useful if a single host has more than one preshared key value. |
| <b>Host Identity</b>      | Value of the host ID represented as an IP address, a fully qualified domain name (FQDN), or a user at the fully qualified domain name ( <i>user@FQDN</i> ). For example, jdoe@studentmail.ut.edu.                                                                                                                                                                            |
| <b>IP Address</b>         | IP address of the remote host. This value is required when the host ID type is KEY_ID or whenever the host ID type cannot be resolved to an IP address. For example, if the user name cannot be resolved with a local name server, the IP address for the remote side must be entered.                                                                                       |

*Data management parameters and policy:*

The data management proposal parameters are set during phase 2 of an IKE tunnel configuration. They are the same IP Security parameters used in manual tunnels and describe the type of protection to be used for protecting data traffic in the tunnel. You can start more than one phase 2 tunnel under the same phase 1 tunnel.

The following endpoint ID types describe the type of data that uses the IP Security Data tunnel:

|                                  |                                                                                                                                                                                                                                                                                                              |
|----------------------------------|--------------------------------------------------------------------------------------------------------------------------------------------------------------------------------------------------------------------------------------------------------------------------------------------------------------|
| <b>Host, Subnet, or Range</b>    | Describes whether the data traffic traveling in the tunnel will be for a particular host, subnet, or address range.                                                                                                                                                                                          |
| <b>Host/Subnet ID</b>            | Contains the host or subnet identity of the local and remote systems passing traffic over this tunnel. Determines the IDs sent in the phase 2 negotiation and the filter rules that will be built if the negotiation is successful.                                                                          |
| <b>Subnet mask</b>               | Describes all IP addresses within the subnet (for example, host 9.53.250.96 and mask 255.255.255.0)                                                                                                                                                                                                          |
| <b>Starting IP Address Range</b> | Provides the starting IP address for the range of addresses that will be using the tunnel (for example, 9.53.250.96 of 9.53.250.96 to 9.53.250.93)                                                                                                                                                           |
| <b>Ending IP Address Range</b>   | Provides the ending IP address for the range of addresses that will be using the tunnel (for example, 9.53.250.93 of 9.53.250.96 to 9.53.250.93)                                                                                                                                                             |
| <b>Port</b>                      | Describes data using a specific port number (for example, 21 or 23)                                                                                                                                                                                                                                          |
| <b>Protocol</b>                  | Describes data being transported with a specific protocol (for example, TCP or UDP). Determines the protocol sent in the phase 2 negotiation and the filter rules that will be built if the negotiation is successful. The protocol for the local endpoint must match the protocol for the remote end point. |

*Choosing a tunnel type:*

The decision to use manual tunnels or IKE tunnels depends on the tunnel support of the remote end and the type of key management desired.

When available, use IKE tunnels because they offer industry-standard secure key negotiation and key refreshment. They also take advantage of the IETF ESP and AH header types and support anti-replay protection. You can optionally configure signature mode to allow digital certificates.

If the remote end uses one of the algorithms requiring manual tunnels, manual tunnels should be used. Manual tunnels ensure interoperability with a large number of hosts. Because the keys are static and difficult to change and might be cumbersome to update, they are not as secure. Manual tunnels can be used between a host running this operating system and any other machine running IP Security and having

a common set of cryptographic and authentication algorithms. Most vendors offer Keyed MD5 with DES, or HMAC MD5 with DES. This subset works with almost all implementations of IP Security.

The procedure used in setting up manual tunnels, depends on whether you are setting up the first host of the tunnel or setting up the second host, which must have parameters matching the first host setup. When setting up the first host, the keys can be autogenerated, and the algorithms can be defaulted. When setting up the second host, import the tunnel information from the remote end, if possible.

Another important consideration is determining whether the remote system is behind a firewall. If it is, the setup must include information about the intervening firewall.

### ***Using IKE with DHCP or dynamically assigned addresses:***

One common scenario for using IP Security with an operating system is when remote systems are initiating IKE sessions with a server, and their identity cannot be tied to a particular IP address.

This case can occur in a Local Area Network (LAN) environment such as using IP Security to connect to a server on a LAN and wanting to encrypt the data. Other common uses involve remote clients dialing into a server and using either a fully qualified domain name (FQDN), or e-mail address (user@FQDN) to identify the remote ID.

In the Key Management phase (Phase 1), an RSA Signature is the only authentication mode supported if you use main mode with non-IP address IDs. In another words, if you want use pre-shared key authentication, you must use aggressive mode or main mode with IP addresses as IDs. In fact, when the number of DHCP clients with whom you want establish IPsec tunnels is large, it becomes impractical to define unique, pre-shared keys for each DHCP client, so it is recommend you use RSA Signature authentication in this scenario. You also can use Group ID as a remote ID in tunnel definition so that you only define the tunnel once with all DHCP clients (see tunnel definition sample file `/usr/samples/ipsec/group_aix_responder.xml`). Group ID is a unique feature of AIX IPsec. You can define a group ID to include any IKE IDs (like a single IP address), FQDN, User FQDN, a range or set of IP addresses, and so on, and then use this Group ID as the phase 1 or phase 2 remote ID in your tunnel definitions.

**Note:** When Group ID is used, tunnel should be defined as Responder role only. That means you must activate this tunnel from the DHCP client side.

For the Data Management phase (Phase 2), when the IP Security associations are being created to encrypt TCP or UDP traffic, a generic data management tunnel can be configured. Therefore, any request that was authenticated during phase 1, will use the generic tunnel for defined Data Management phase if the IP address is not explicitly configured in the database. This allows any address to match the generic tunnel and can be used as long as the rigorous public key-based security validation was successful in phase 1.

### ***Using XML to define a generic data management tunnel:***

You can define a generic Data Management tunnel using the XML format understood by **ikedb**.

See the section entitled “Command-line interface for IKE tunnel configuration” on page 228 for more information on the IKE XML interface and the **ikedb** command. Generic Data Management tunnels are used with DHCP. The XML format uses the tag name IPsecTunnel for what Web-based System Manager calls a Data Management tunnel. This is also referred to as a *phase 2 tunnel* in other contexts. A *generic Data Management tunnel* is not a true tunnel, but an IPsecProtection that is used if an incoming Data Management message (under a specific Key Management tunnel) does not match any Data Management tunnel defined for that Key Management tunnel. It is only used in the case where the AIX system is the responder. Specifying a generic Data Management tunnel IPsecProtection is optional.

The generic Data Management tunnel is defined in the IKEProtection element. There are two XML attributes, called *IKE\_IPSecDefaultProtectionRef* and *IKE\_IPSecDefaultAllowedTypes*, that are used for this.

First, you need to define an IPSecProtection that you would like to use as the default if no IPSecTunnels (Data Management tunnels) match. An IPSecProtection that is to be used as a default must have an IPSec\_ProtectionName that begins with *\_defIPSProt\_*.

Now go to the IKEProtection that you would like to use this default IPSecProtection. Specify an **IKE\_IPSecDefaultProtectionRef** attribute that contains the name of the default IPSec\_Protection.

You must also specify a value for the **IKE\_IPSecDefaultAllowedTypes** attribute in this IKEProtection. It can have one or more of the following values (if multiple values, they should be space-separated):

```
Local_IPV4_Address
Local_IPV6_Address
Local_IPV4_Subnet
Local_IPV6_Subnet
Local_IPV4_Address_Range
Local_IPV6_Address_Range
Remote_IPV4_Address
Remote_IPV6_Address
Remote_IPV4_Subnet
Remote_IPV6_Subnet
Remote_IPV4_Address_Range
Remote_IPV6_Address_Range
```

These values correspond to the ID types specified by the initiator. In the IKE negotiation, the actual IDs are ignored. The specified IPSecProtection is used if the **IKE\_IPSecDefaultAllowedTypes** attribute contains a string beginning with *Local\_* that corresponds to the initiator's local ID type, and contains a string beginning with *Remote\_* that corresponds to the initiator's remote ID type. In other words, you must have at least one *Local\_* value and at least one *Remote\_* value in any **IKE\_IPSecDefaultAllowedTypes** attribute in order for the corresponding IPSec\_Protection to be used.

*General data management tunnel example:*

A Data Management tunnel can be used to send a message to the system.

An initiator sends the following to the AIX system in a phase 2 (Data Management) message:

```
local ID type: IPV4_Address
local ID: 192.168.100.104

remote ID type: IPV4_Subnet
remote ID: 10.10.10.2
remote netmask: 255.255.255.192
```

The AIX system does not have a Data Management tunnel matching these IDs. But it does have an IPSecProtection with the following attributes defined:

```
IKE_IPSecDefaultProtectionRef="_defIPSProt_protection4"
IKE_IPSecDefaultAllowedTypes="Local_IPV4_Address
Remote_IPV4_Address
Remote_IPV4_Subnet
Remote_IPV4_Address_Range"
```

The local ID type of the incoming message, *IPV4\_Address*, matches one of the *Local\_* values of the allowed types, *Local\_IPV4\_Address*. Also, the remote ID of the message, *IPV4\_Subnet*, matches the value *Remote\_IPV4\_Subnet*. Therefore the Data Management tunnel negotiation will proceed with *\_defIPSProt\_protection4* as the IPSecProtection.



The `/usr/samples/ipsec/default_p2_policy.xml` file is a full XML file defining a generic IPSecProtection that can be used as an example.

*Using Web-based System Manager to define a generic data management tunnel:*

You can use the Web-based System Manager to define a generic Data Management tunnel.

To define a generic Data Management tunnel using the Web-based System Manager interface do the following:

1. Select a Key Management tunnel in the IKE Tunnels container, and select the action to Define a Data Management Tunnel.
2. Select generic Data Management tunnel. The configuration panels are similar to the panels used to define a Data Management tunnel. However, the choices for the ID types are different. Explicit IDs do not need to be specified. The ID types, which are IP V4 or V6 Address Only, IP V4 or V6 Subnet Only, and IP V4 or V6 Address or Subnet, cover all allowable cases of IDs.
3. Set the rest of the information the same way as in a Data Management Tunnel and click OK. Each Key Management tunnel can only have one associated Generic Tunnel.

**Note:** A generic data management tunnel can *only* be used in the case where the AIX system is the responder.

## Configuring Internet key exchange tunnels

You can configure Internet Key Exchange (IKE) tunnels using the Web-based System Manager interface, the System Management Interface Tool (SMIT), or the command line.

*Using Web-based System Manager to configure IKE tunnels:*

Web-based System Manager can be used to configure IKE tunnels.

*Using the basic configuration wizard:*

You can use the the basic configuration wizard to define an IKE tunnel through Web-based System Manager using pre-shared keys or certificates as the authentication method.

The Web-based System Manager adds new key management and data management IKE tunnels to the IP Security subsystem, allows you to input minimal data and choose some options, and makes use of common default values for such parameters as tunnel lifetime.

When using the basic configuration wizard, keep the following in mind:

- The wizard can be used only for initial tunnel configuration. To modify, delete, or activate a tunnel, use the IKE Tunnel plug-in or task bar.
- The tunnel name must be unique on your system, but you can use the same name on the remote system. For example, on the local and remote systems, the tunnel name can be `hostA_to_hostB`, but the Local IP Address and the Remote IP Address fields (endpoints) are switched.
- Phase 1 and phase 2 tunnels are defined with the same encryption and authentication algorithms.
- The preshared key must be entered in hexadecimal form (without a leading 0x) or ASCII text.
- If digital certificates are chosen as the authentication method, you must use the Key Manager tool to create a digital certificate.
- The host ID type can only be IP Address.
- The transforms and proposals you create are assigned names that end with the user-defined tunnel name. You can view the transforms and proposals in Web-based System Manager through **VPN** and the **IKE Tunnel** plug-in.

Use the following procedure to configure a new tunnel using the wizard:

1. Open Web-based System Manager using the **wsm** command from the command line.
2. Select the Network plug-in.
3. Select **Virtual Private Networks (IP Security)**.
4. From the Console area, select the **Overview and Tasks** folder.
5. Select **Configure a Basic Tunnel Configuration wizard**.
6. Click on **Next** on the Step 1 Introduction panel, and then follow the steps to configure an IKE tunnel. Online help is available by pressing F1 if you need it.  
After a tunnel is defined using the wizard, the tunnel definition displays in the Web-based System Manager IKE tunnels list and can be activated or modified.

*Advanced IKE tunnel configuration:*

You can configure key management and data management tunnels separately, using the following procedures.

*Configuring key management tunnels:*

IKE tunnels are configured using Web-based System Manager.

Perform the following steps to add a key management tunnel:

1. Open Web-based System Manager using the **wsm** command.
2. Select the Network plug-in.
3. Select **Virtual Private Networks (IP Security)**.
4. From the Console area, select **Overview and Tasks**.
5. Select **Start IP Security**. This action loads the IP Security kernel extensions and starts the **isakmpd**, **tmd**, and **cpsd** daemons.

A tunnel is created by defining the key management and data management endpoints and their associated security transforms and proposals.

- Key management is the authentication phase. It sets up a secure channel between the negotiating parties needed before the final IP Security parameters and keys are computed.
- Data management describes the type of traffic that will be using a particular tunnel. It can be configured for a single host or group of hosts (with the use of subnets or IP ranges) along with specified protocol and port numbers.

The same key management tunnel can be used to protect multiple data management negotiations and key refreshes, as long as they take place between the same two endpoints; for example, between two gateways.

6. To define the key management tunnel endpoints, click **Internet Key Exchange (IKE) Tunnels** on the Identification tab.
7. Enter information to describe the identities of the systems taking part in the negotiations. In most cases, IP addresses are used, and a policy compatible with the remote side must be created.  
On the Transforms tab, use matching transforms on both sides, or contact the administrator on the remote end to define a matching transform. A transform containing several choices can be created to allow flexibility when proposing or matching on a transform.
8. If using preshared keys for authentication, enter the preshared key under the **key** tab. This value must match on both the remote and local machines.
9. Create a transform to be associated with this tunnel by clicking **Add** on the Transforms tab.  
To enable digital certificates and signature mode support, choose an authentication method of RSA Signature or RSA Signature with CRL Checking.  
For more information about digital certificates, see “Digital certificates and the key manager concepts” on page 231.

### *Configuring data management tunnels:*

To complete IKE tunnel setup, you need to configure data management tunnel endpoints and proposals.

Open Web-based System Manager, as described in “Creating IKE tunnels using digital certificates” on page 239. Perform the following steps to create a data management tunnel:

1. Select a key management tunnel and define any unique options. Most data management options can remain as defined by the default.
2. Specify endpoint types (such as IP address, subnet, or IP address range) under the Endpoints tab. You can select a port number and protocol or accept the default.
3. On the Proposals panel, you can create a new proposal by clicking the **Add** button or clicking **OK** to create a proposal. If there are multiple proposals, you can use the Move Up or Move Down buttons to change the search order.

### *Group support:*

IP security supports grouping IKE IDs in a tunnel definition to associate multiple IDs with a single security policy without having to create separate tunnel definitions.

Grouping is especially useful when setting up connections to several remote hosts, because you can avoid setting up or managing multiple tunnel definitions. Also, if changes must be made to a security policy, you do not need to change multiple tunnel definitions.

A group must be defined before using that group name in a tunnel definition. The group's size is limited to 1 KB. On the initiator's side of the negotiation, you can use groups as a remote ID in data management tunnel definitions only. On the responders side of the negotiation, you can use groups as a remote ID in key management and data management tunnel definitions.

A group is composed of a group name and a list of IKE IDs and ID types. IDs can be the same type or a mix of the following:

- IPv4 addresses
- IPv6 addresses
- FQDN
- user@FQDN
- X500 DN types

During a Security Association negotiation, the IDs in a group are searched linearly for the first match.

Web-based System Manager can be used to define a group that is to be used for the remote endpoint of a Key Management tunnel. To define a group using Web-based System Manager, perform the following steps:

1. Select a Key Management tunnel in the IKE Tunnel container.
2. Open the **Properties** dialog.
3. Select the **Identification** tab.
4. Select **group ID definition** for the remote host identity type.
5. Select the **Configure Group Definition** button and enter the group members in the window.

Refer to “Command-line interface for IKE tunnel configuration” on page 228 for information on defining groups from the command line.

### ***Using the SMIT interface for IKE tunnel configuration:***

You can use the SMIT interface to configure IKE tunnels and perform basic IKE database functions.

SMIT uses underlying XML command functions to perform additions, deletions, and modifications to the IKE tunnel definitions. IKE SMIT is used in configuring IKE tunnels quickly and provides examples of the XML syntax used to create IKE tunnel definitions. The IKE SMIT menus also allow you to back up, restore, and initialize the IKE database.

To configure an IPv4 IKE tunnel, use the **smitty ike4** fast path. To configure an IPv6 IKE tunnel, use the **smitty ike6** fast path. The IKE database functions can be found in the Advanced IP Security Configuration menu.

All IKE database entries added through SMIT can be viewed or modified through the Web-based System Manager tool.

### **Command-line interface for IKE tunnel configuration:**

The **ikedb** command allows a user to retrieve, update, delete, import, and export information in the IKE database using an XML interface.

The **ikedb** command allows the user to write to (put) or read from (get) the IKE database. The input and output format is an Extensible Markup Language (XML) file. The format of an XML file is specified by its Document Type Definition (DTD). The **ikedb** command allows the user to see the DTD that is used to validate the XML file when doing a put. While entity declarations can be added to the DTD using the **-e** flag, this is the only modification to the DTD that can be made. Any external DOCTYPE declaration in the input XML file will be ignored and any internal DOCTYPE declaration might result in an error. The rules followed to parse the XML file using the DTD are specified in the XML standard. The **/usr/samples/ipsec** file has a sample of a typical XML file that defines common tunnel scenarios. See the **ikedb** command description in the *AIX Version 6.1 Commands Reference* for syntax details.

You can use the **ike** command to start, stop, and monitor IKE tunnels. The **ike** command can also be used to activate, remove, or list IKE and IP Security tunnels. See the **ike** command description in the *AIX Version 6.1 Commands Reference* for syntax details.

The following examples show how to use **ike**, **ikedb**, and several other commands to configure and check the status of your IKE tunnel:

1. To start a tunnel negotiation (*activate* a tunnel) or to allow the incoming system to act as a responder (depending on the role that is specified), use the **ike** command with a tunnel number, as follows:

```
ike cmd=activate numlist=1
```

You can also use remote id or IP addresses, as shown in the following examples:

```
ike cmd=activate remid=9.3.97.256
ike cmd=activate ipaddr=9.3.97.100, 9.3.97.256
```

Because it might take several seconds for the commands to complete, the command returns after the negotiation is started.

2. To display the tunnel status, use the **ike** command, as follows:

```
ike cmd=list
```

The output looks similar to the following:

```
Phase 1 Tunnel ID [1]
Phase 2 Tunnel ID [1]
```

The output shows phase 1 and phase 2 tunnels that are currently active.

3. To get a verbose listing of the tunnel, use the **ike** command, as follows:

```
ike cmd=list verbose
```

The output looks similar to the following:

```
Phase 1 Tunnel ID 1
Local ID Type: Fully_Qualified_Domain_Name
Local ID: bee.austin.ibm.com
```

```

Remote ID Type: Fully_Qualified_Domain_Name
Remote ID: ipsec.austin.ibm.com
Mode: Aggressive
Security Policy: BOTH_AGGR_3DES_MD5
Role: Initiator
Encryption Alg: 3DES-CBC
Auth Alg: Preshared Key
Hash Alg: MD5
Key Lifetime: 28800 Seconds
Key Lifesize: 0 Kbytes
Key Rem Lifetime: 28737 Seconds
Key Rem Lifesize: 0 Kbytes
Key Refresh Overlap: 5%
Tunnel Lifetime: 2592000 Seconds
Tunnel Lifesize: 0 Kbytes
Tun Rem Lifetime: 2591937 Seconds
Status: Active

```

```

Phase 2 Tunnel ID 1
Local ID Type: IPv4_Address
Local ID: 10.10.10.1
Local Subnet Mask: N/A
Local Port: any
Local Protocol: all
Remote ID Type: IPv4_Address
Remote ID: 10.10.10.4
Remote Subnet Mask: N/A
Remote Port: any
Remote Portocol: all
Mode: Oakley_quick
Security Policy: ESP_3DES_MD5_SHA_TUNNEL_NO_PFS
Role: Initiator
Encryption Alg: ESP_3DES
AH Transform: N/A
Auth Alg: HMAC-MD5
PFS: No
SA Lifetime: 600 Seconds
SA Lifesize: 0 Kbytes
SA Rem Lifetime: 562 Seconds
SA Rem Lifesize: 0 Kbytes
Key Refresh Overlap: 15%
Tunnel Lifetime: 2592000 Seconds
Tunnel Lifesize: 0 Kbytes
Tun Rem Lifetime: 2591962 Seconds
Assoc P1 Tunnel: 0
Encap Mode: ESP_tunnel
Status: Active

```

4. To display the filter rules in the dynamic filter table for the newly activated IKE tunnel, use the **lsfilt** command as follows:

```
lsfilt -d
```

The output looks similar to the following example:

```

1 permit 0.0.0.0 0.0.0.0 0.0.0.0 0.0.0.0 no udp eq 4001 eq 4001 both both no all
 packets 0 all
2 *** Dynamic filter placement rule *** no
0 permit 0.0.0.0 0.0.0.0 0.0.0.0 0.0.0.0 yes all any 0 any 0 both both no all
 packets 0 all

*** Dynamic table ***

0 permit 0.0.0.0 0.0.0.0 0.0.0.0 0.0.0.0 no udp eq 500 eq 500 local both no all
 packets 0
0 permit 0.0.0.0 0.0.0.0 0.0.0.0 0.0.0.0 no ah any 0 any 0 both inbound no all
 packets 0
0 permit 0.0.0.0 0.0.0.0 0.0.0.0 0.0.0.0 no esp any 0 any 0 both inbound no all

```

```

packets 0
1 permit 10.10.10.1 255.255.255.255 10.10.10.4 255.255.255.255 no all any 0 any
0 both outbound yes all packets 1
1 permit 10.10.10.4 255.255.255.255 10.10.10.1 255.255.255.255 no all any 0 any
0 both inbound yes all packets 1

```

This example shows a machine that has one IKE tunnel and no other tunnels. The dynamic filter placement rule (rule #2 in this example output of the static table) can be moved by the user to control placement relative to all other user-defined rules. The rules in the dynamic table are constructed automatically as tunnels are negotiated and corresponding rules are inserted into the filter table. These rules can be displayed, but not edited.

5. To turn on logging of the dynamic filter rules, set the logging option for rule #2 to Yes, use the **chfilt** command, as shown in the following example:

```
chfilt -v 4 -n 2 -l y
```

For more details on logging IKE traffic, see “Logging facilities” on page 252.

6. To deactivate the tunnel, use the **ike** command as follows:

```
ike cmd=remove numlist=1
```

7. To view tunnel definitions, use the **ikedb** command as follows:

```
ikedb -g
```

8. To put definitions to the IKE database from an XML file that has been generated on a peer machine and overwrite any existing objects in the database with the same name, use the **ikedb** command as follows:

```
ikedb -pFs peer_tunnel_conf.xml
```

The **peer\_tunnel\_conf.xml** is the XML file generated on a peer machine.

9. To get the definition of the phase 1 tunnel named *tunnel\_sys1\_and\_sys2* and all dependent phase 2 tunnels with respective proposals and protections, use the **ikedb** command, as follows:

```
ikedb -gr -t IKEtunnel -n tunnel_sys1_and_sys2
```

10. To delete all preshared keys from the database, use the **ikedb** command, as follows:

```
ikedb -d -t IKEPresharedKey
```

For general information on IKE tunnel group support, see “Group support” on page 227. You can use the **ikedb** command to define groups from the command line.

### *AIX IKE and Linux affinity:*

It is possible to configure an AIX IKE tunnel using Linux configuration files.

To configure an AIX IKE tunnel using Linux configuration files (AIX 5.1 and later), use the **ikedb** command with the **-c** flag (conversion option), which lets you use the **/etc/ipsec.conf** and **/etc/ipsec.secrets** Linux configuration files as IKE tunnel definitions. The **ikedb** command parses the Linux configuration files, creates an XML file, and optionally adds the XML tunnel definitions to the IKE database. You can then view the tunnel definitions by using either the **ikedb -g** command or the Web-based System Manager.

### ***IKE tunnel configuration scenarios:***

The following scenarios describe the type of situations most customers encounter when trying to set up tunnels. These scenarios can be described as the branch office, business partner, and remote access cases.

- In the branch office case, the customer has two trusted networks that they want to connect together—the engineering group of one location to the engineering group of another. In this example, there are gateways that connect to each other and all the traffic passing between the gateways use the same tunnel. The traffic at either end of the tunnel is decapsulated and passes in the clear within the company intranet.

In the first phase of the IKE negotiation, the IKE security association is created between the two gateways. The traffic that passes in the IP Security tunnel is the traffic between the two subnets, and the subnet IDs are used in the phase 2 negotiation. After the security policy and tunnel parameters are entered for the tunnel, a tunnel number is created. Use the **ike** command to start the tunnel.

- In the business partner scenario, the networks are not trusted, and the network administrator may want to restrict access to a smaller number of hosts behind the security gateway. In this case, the tunnel between the hosts carries traffic protected by IP Security for use between two particular hosts. The protocol of the phase 2 tunnel is AH or ESP. This host-to-host tunnel is secured within a gateway-to-gateway tunnel.
- In the remote access case, the tunnels are set up on demand and a high level of security is applied. The IP addresses may not be meaningful, therefore, fully qualified domain names or *user@* fully qualified domain names are preferred. Optionally, you can use KEYID to relate a key to a host ID.

## Digital certificates and the key manager concepts

Digital certificates bind an identity to a public key, through which you can verify the sender or the recipient of an encrypted transfer.

Beginning with AIX 4.3.2, IP Security uses digital certificates to enable *public-key cryptography*, also known as *asymmetric cryptography*, which encrypts data using a private key known only to the user and decrypts it using an associated public (shared) key from a given public-private key pair. *Key pairs* are long strings of data that act as keys to a user's encryption scheme.

In public-key cryptography, the public key is given to anyone with whom the user wants to communicate. The sender digitally signs all secure communications with the corresponding private key for their assigned key pair. The recipient uses the public key to verify the sender's signature. If the message is successfully decrypted with the public key, the receiver can verify that the sender was authenticated.

Public-key cryptography relies on trusted, third parties, known as a *certification authorities (CAs)*, to issue reliable digital certificates. The recipient specifies which issuing organizations or authorities are deemed trusted. A certificate is issued for a specific amount of time; when its expiration date has passed, it must be replaced.

AIX 4.3.2 and later versions provide the Key Manager tool, which manages digital certificates. The following sections provide conceptual information about the certificates themselves.

### **Format of digital certificates:**

The digital certificate contains specific pieces of information about the identity of the certificate owner and about the certification authority. See the following figure for an illustration of a digital certificate.

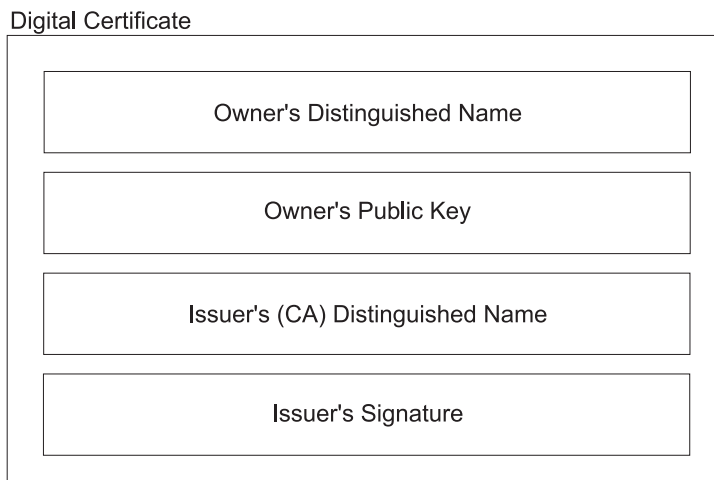

### Contents of a Digital Certificate

Figure 10. Contents of a Digital Certificate

This illustration shows the four entities of a digital certificate. From the top they are, Owner's Distinguished Name, Owners Public Key, Issuer's (CA) Distinguished Name, and Issuer's Signature.

The following list further describes the contents of the digital certificate:

#### Owner's Distinguished Name

Combination of the owner's common name and context (position) in the directory tree. In the following figure of a simple directory tree, for example, Prasad is the owner's common name and the context is country=US, organization=ABC, lower organization=SERV; therefore, the distinguished name is:

/C=US/O=ABC/OU=SERV/CN=prasad.austin.ibm.com

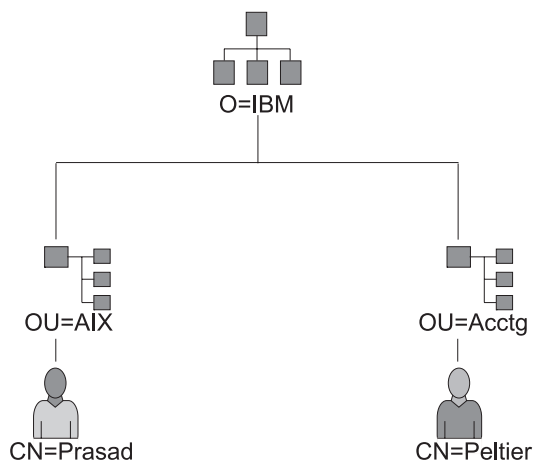

#### Example of Deriving Distinguished Name from Directory Tree

Figure 11. Example of Deriving Distinguished Name from Directory Tree



This illustration is a directory tree with O=ABC at the top level and branching to two entities on the second level. Level two contains OU=AIX and OU=Acctg on separate branches; each has a branch leading to a single entity on the last level. The last level contains CN=Prasad and CN=Peltier respectively.

**Owner's Public Key**

Used by the recipients to decrypt data.

**Subject Alternate Name**

Can be an identifier such as an IP address, e-mail address, fully qualified domain name, and so on.

**Issue Date**

Date the digital certificate was issued.

**Expiration Date**

Date the digital certificate expires.

**Issuer's Distinguished Name**

Distinguished name of the Certification Authority.

**Issuer's Digital Signature**

Digital signature used to validate a certificate.

***Security considerations for digital certificates:***

A digital certificate alone cannot prove identity.

The digital certificate only allows you to verify the identity of the digital certificate owner by providing the public key that is needed to check the owner's digital signature. You can safely send your public key to another because your data cannot be decrypted without the other part of the key pair, your private key. Therefore, the owner must protect the private key that belongs to the public key in the digital certificate. All communications of the owner of a digital certificate can be deciphered, if the private key is known. Without the private key, a digital certificate cannot be misused.

*Certification authorities and trust hierarchies:*

A digital certificate is only as trustworthy as the certification authority (CA) that issued it.

As part of this trust, the policies under which certificates are issued should be understood. Each organization or user must determine which certification authorities can be accepted as trustworthy.

The Key Manager tool also allows organizations to create self-signed certificates, which can be useful for testing or in environments with a small number of users or machines.

As a user of a security service, you need to know its public key to obtain and validate any digital certificates. Also, simply receiving a digital certificate does not assure its authenticity. To verify its authenticity, you need the public key of the certification authority that issued that digital certificate. If you do not already hold an assured copy of the CA's public key, then you might need an additional digital certificate to obtain the CA's public key.

***Certificate revocation lists:***

A digital certificate is expected to be used for its entire validity period. If needed, however, a certificate can be invalidated before its actual date of expiration.

Invalidating the certificate might be necessary, for example, if an employee leaves the company or if the certificate's private key has been compromised. To invalidate a certificate, you must notify the appropriate

Certificate Authority (CA) of the circumstances. When a CA revokes a certificate, it adds the invalid certificate serial number to a Certificate Revocation List (CRL).

CRLs are signed data structures that are issued periodically and made available in a public repository. CRLs can be retrieved from HTTP or LDAP servers. Each CRL contains a current time stamp and a nextUpdate time stamp. Each revoked certificate in the list is identified by its certificate serial number.

When configuring an IKE tunnel and using digital certificates as your authentication method, you can confirm the certificate has not been revoked by selecting RSA Signature with CRL Checking. If CRL Checking is enabled, the list is located and checked during the negotiation process to establish the key management tunnel.

**Note:** To use this feature of IP Security, your system must be configured to use a SOCKS server (version 4 for HTTP servers), an LDAP server, or both. If you know which SOCKS or LDAP server you are using to obtain CRLs, you can make the necessary configuration selections by using Web-based System Manager. Select **CRL Configuration** from the Digital Certificates menu.

### ***Uses for digital certificates in Internet applications:***

Internet applications that use public-key cryptography systems must use digital certificates to obtain the public keys.

There are many applications that use public-key cryptography, including the following ones:

#### **Virtual Private Networks (VPN)**

Virtual Private Networks, also called *secure tunnels*, can be set up between systems such as firewalls to enable protected connections between secure networks over unsecured communication links. All traffic destined to these networks is encrypted between the participating systems.

The protocols used in tunneling follow the IP Security and IKE standards, which allow for a secure, encrypted connection between a remote client (for example, an employee working from home) and a secure host or network.

#### **Secure Sockets Layer (SSL)**

SSL is a protocol that provides privacy and integrity for communications. It is used by Web servers for secure connections between Web servers and Web browsers, by the Lightweight Directory Access Protocol (LDAP) for secure connections between LDAP clients and LDAP servers, and by Host-on-Demand V.2 for connections between the client and the host system. SSL uses digital certificates for key exchange, server authentication, and, optionally, client authentication.

#### **Secure Electronic Mail**

Many electronic mail systems, using standards such as PEM or S/MIME for secure electronic mail, use digital certificates for digital signatures and for the exchange of keys to encrypt and decrypt mail messages.

### ***Digital certificates and certificate requests:***

A *certificate request* must be created and sent to a CA to request a digital certificate.

A signed digital certificate contains fields for the owner's distinguished name, the owner's public key, the CA's distinguished name and the CA's signature. A self-signed digital certificate contains its owner's distinguished name, public key, and signature.

The certificate request contains fields for the requestor's distinguished name, public key, and signature. The CA verifies the requestor's signature with the public key in the digital certificate to ensure that:

- The certificate request was not modified in transit between the requestor and the CA.

- The requestor possesses the corresponding private key for the public key that is in the certificate request.

The CA is also responsible for verifying to some level the identity of the requestor. Requirements for this verification can range from very little proof to absolute assurance of the owner's identity.

### **Key Manager tool:**

The Key Manager tool manages digital certificates, and is located in the **gskkm.rte** file set on the expansion pack.

To set up digital certificates and signature support, at minimum you must do tasks 1, 2, 3, 4, 6, and 7. Then, use Web-based System Manager to create an IKE tunnel and associate a policy with the tunnel that uses RSA Signature as the authentication method.

You can create and configure a key database from the Web-based System Manager VPN Overview window by selecting the Managing Digital Certificates option, or by using the `certmgr` command to open the Key Manager tool from the command line.

This section describes how to use Key Manager to do the following tasks:

#### *Creating a key database:*

A key database enables VPN endpoints to connect using valid digital certificates. The key database (\*.kdb) format is used with IP Security VPNs.

The following types of CA digital certificates are provided with Key Manager:

- RSA Secure Server Certification Authority
- Thawte Personal Premium Certification Authority
- Thawte Personal Freemail Certification Authority
- Thawte Personal Basic Certification Authority
- Thawte Personal Server Certification Authority
- Thawte Server Certification Authority
- Verisign Class 1 Public Primary Certification Authority
- Verisign Class 2 Public Primary Certification Authority
- Verisign Class 3 Public Primary Certification Authority
- Verisign Class 4 Public Primary Certification Authority

These signature digital certificates enable clients to attach to servers that have valid digital certificates from these signers. After you create a key database, you can use it as created to attach to a server that has a valid digital certificate from one of the signers.

To use a signature digital certificate that is not on this list, you must request it from the CA and add it to your key database. See "Adding a CA root digital certificate" on page 236.

To create a key database using the **certmgr** command, use the following procedure:

1. Start the Key Manager tool by typing:  
`# certmgr`
2. Select **New** from the Key Database File list.
3. Accept the default value, CMS key database file, for the **Key database type** field.
4. Enter the following file name in the **File Name** field:  
`i kekey.kdb`

5. Enter the following location of the database in the **Location** field:

`/etc/security`

**Note:** The key database must be named **ikekey.kbd** and it must be placed in the **/etc/security** directory. Otherwise, IP Security cannot function correctly.

6. Click **OK**. The **Password Prompt** screen is displayed.
7. Enter a password in the **Password** field, and enter it again in the **Confirm Password** field.
8. If you want to change the number of days until the password expires, enter the desired number of days in the **Set expiration time?** field. The default value for this field is 60 days. If you do not want the password to expire, clear the **Set expiration time?** field.
9. To save an encrypted version of the password in a stash file, select the **Stash the password to a file?** field and enter Yes.

**Note:** You must stash the password to enable the use of digital certificates with IP Security.

10. Click **OK**. A confirmation screen displays, verifying that you have created a key database.
11. Click **OK** again and you return to the IBM Key Management screen. You can either perform other tasks or exit the tool.

#### *Adding a CA root digital certificate:*

After you have requested and received a root digital certificate from a CA, you can add it to your database.

Most root digital certificates are of the form \*.arm, such as the following example:

`cert.arm`

To add a CA root digital certificate to a database, use the following procedure:

1. Unless you are already using Key Manager, start the tool by typing:  
`# certmgr`
2. From the main screen, select **Open** from the Key Database File list.
3. Highlight the key database file to which you want to add a CA root digital certificate and click **Open**.
4. Enter the password and click **OK**. When your password is accepted, you are returned to the IBM Key Management screen. The title bar now shows the name of the key database file you selected, indicating that the file is now open and ready to be worked with.
5. Select **Signer Certificates** from the **Personal/Signer Certificates** list.
6. Click **Add**.
7. Select a data type from the **Data type** list, such as:  
Base64-encoded ASCII data
8. Enter a certificate file name and location for the CA root digital certificate, or click **Browse** to select the name and location.
9. Click **OK**.
10. Enter a label for the CA root digital certificate, such as Test CA Root Certificate, and click **OK**. You are returned to the **Key Management** screen. The **Signer Certificates** field now shows the label of the CA root digital certificate you just added. You can either perform more tasks or exit the tool.

#### *Establishing trust settings:*

Installed CA certificates are set to trusted by default. You can change the trust setting if needed.

To change the trust setting, do the following steps:

1. Unless you are already using Key Manager, start the tool by typing:

```
certmgr
```

2. From the main screen, select **Open** from the **Key Database File** list.
3. Highlight the key database file in which you want to change the default digital certificate and click **Open**.
4. Enter the password and click **OK**. After your password is accepted, you are returned to the **IBM Key Management** screen. The title bar shows the name of the key database file you selected, indicating that the file is now open.
5. Select **Signer Certificates** from the **Personal/Signer Certificates** list.
6. Highlight the certificate you want to change and click **View/Edit**, or double-click on the entry. The **Key Information** screen is displayed for the certificate entry.
7. To make this certificate a trusted root certificate, select the check box next to **Set the certificate as a trusted root** and click **OK**. If the certificate is not trusted, clear the check box instead and click **OK**.
8. Click **OK** from the **Signer Certificates** screen. You are returned to the **IBM Key Management** screen. You can either perform other tasks or exit the tool.

#### *Deleting a CA root digital certificate:*

If you no longer want to use one of the CAs in your signature digital certificate list, you must delete the CA root digital certificate.

**Note:** Before deleting a CA root digital certificate, create a backup copy in case you later want to recreate the CA root.

To delete a CA root digital certificate from a database, use the following procedure:

1. Unless you are already using Key Manager, start the tool by typing:  

```
certmgr
```
2. From the main screen, select **Open** from the **Key Database File** list.
3. Highlight the key database file from which you want to delete a CA root digital certificate and click **Open**.
4. Enter the password and click **OK**. After your password is accepted, you are returned to the **Key Management** screen. The title bar shows the name of the key database file you selected, indicating that the file is now open and ready to be edited.
5. Select **Signer Certificates** from the **Personal/Signer Certificates** list.
6. Highlight the certificate you want to delete and click **Delete**. The **Confirm** screen is displayed.
7. Click **Yes**. You are returned to the **IBM Key Management** screen. The label of the CA root digital certificate no longer appears in the **Signer Certificates** field. You can either perform other tasks or exit the tool.

#### *Requesting a digital certificate:*

To acquire a digital certificate, generate a request using Key Manager and submit the request to a CA. The request file you generate is in the PKCS#10 format. The CA then verifies your identity and sends you a digital certificate.

To request a digital certificate, use the following procedure:

1. Unless you are already using Key Manager, start the tool by typing:  

```
certmgr
```
2. From the main screen, select **Open** from the **Key Database File** list.
3. Highlight the **/etc/security/ikekey.kdb** key database file from which you want to generate the request and click **Open**.

4. Enter the password and click **OK**. After your password is accepted, you are returned to the **IBM Key Management** screen. The title bar shows the name of the key database file you selected, indicating that the file is now open and ready to be edited.
5. Select **Personal Certificate Requests** from the **Personal/Signer Certificates** list (in AIX Version 4) or select **Create** → **New Certificate Request** (beginning in AIX 5.1).
6. Click **New**.
7. From the following screen, enter a Key Label for the self-signed digital certificate, such as:  
keytest
8. Enter a common name (the default is the host name) and organization, and then select a country. For the remaining fields, either accept the default values, or choose new values.
9. Define the subject alternate name. The optional fields associated with subject alternate are e-mail address, IP address, and DNS name. For a tunnel type of IP address, type the same IP address that is configured in the IKE tunnel into the IP address field. For a tunnel ID type of *user@FQDN*, complete the e-mail address field. For a tunnel ID type of FQDN, type a fully qualified domain name (for example, *hostname.companyname.com*) in the DNS name field.
10. At the bottom of the screen, enter a name for the file, such as:  
certreq.arm
11. Click **OK**. A confirmation screen is displayed, verifying that you have created a request for a new digital certificate.
12. Click **OK**. You are returned to the **IBM Key Management** screen. The **Personal Certificate Requests** field now shows the key label of the new digital certificate request (PKCS#10) created.
13. Send the file to a CA to request a new digital certificate. You can either perform other tasks or exit the tool.

*Adding (Receiving) a new digital certificate:*

After you receive a new digital certificate from a CA, you must add it to the key database from which you generated the request.

To add (receive) a new digital certificate, use the following procedure:

1. Unless you are already using Key Manager, start the tool by typing:  
# certmgr
2. From the main screen, select **Open** from the **Key Database File** list.
3. Highlight the key database file from which you generated the certificate request and click **Open**.
4. Enter the password and click **OK**. After your password is accepted, you are returned to the IBM Key Management screen. The title bar shows the name of the key database file you selected, indicating that the file is now open and ready to be edited.
5. Select **Personal Certificate Requests** from the **Personal/Signer Certificates** list.
6. Click **Receive** to add the newly received digital certificate to your database.
7. Select the data type of the new digital certificate from the **Data type** list. The default is **Base64-encoded ASCII data**.
8. Enter the certificate file name and location for the new digital certificate, or click **Browse** to select the name and location.
9. Click **OK**.
10. Enter a descriptive label for the new digital certificate, such as:  
VPN Branch Certificate
11. Click **OK**. You are returned to the **IBM Key Management** screen. The **Personal Certificates** field now shows the label of the new digital certificate you just added. You can either perform other tasks or exit the tool. If there is an error loading the certificate, check that the certificate file begins with the text `---BEGIN CERTIFICATE---` and ends with the text `---END CERTIFICATE---`.

For example:

```
-----BEGIN CERTIFICATE-----
ajdkfjaldfwwwwwwwwadafdw
kajf;kdsajkf1asafkjafda
akdjf;l dasjkf;safdfdasfdas
kaj;fdljk98dafdas43adfadfa
-----END CERTIFICATE-----
```

If the text does not match, edit the certificate file so that it starts and ends appropriately.

#### *Deleting a digital certificate:*

At times it will be necessary to delete a digital certificate.

**Note:** Before deleting a digital certificate, create a backup copy in case you later want to re-create it.

To delete a digital certificate from your database, use the following procedure:

1. Unless you are already using Key Manager, start the tool by typing:  
# certmgr
2. From the main screen, select **Open** from the **Key Database File** list.
3. Highlight the key database file from which you want to delete the digital certificate and click **Open**.
4. Enter the password and click **OK**. After your password is accepted, you are returned to the **IBM Key Management** screen. The title bar shows the name of the key database file you selected, indicating that the file is now open and ready to be edited.
5. Select **Personal Certificate Requests** from the **Personal/Signer Certificates** list.
6. Highlight the digital certificate you want to delete and click **Delete**. The **Confirm** screen is displayed.
7. Click **Yes**. You are returned to the **IBM Key Management** screen. The label of the digital certificate you just deleted no longer appears in the **Personal Certificates** field. You can either perform other tasks or exit the tool.

#### *Changing a database password:*

At times it will be necessary to change a database password.

To change the key database, use the following procedure:

1. Unless you are already using Key Manager, start the tool by typing:  
# certmgr
2. From the main screen, select **Change Password** from the **Key Database File** list.
3. Enter a new password in the **Password** field, and enter it again in the **Confirm Password** field.
4. If you want to change the number of days until the password expires, enter the desired number of days in the **Set expiration time?** field. The default value for this field is 60 days. If you do not want the password to expire, clear the **Set expiration time?** field.
5. To save an encrypted version of the password in a stash file, select the **Stash the password to a file?** field and enter Yes.

**Note:** You must stash the password to enable the use of digital certificates with IP Security.

6. Click **OK**. A message in the status bar indicates that the request completed successfully.
7. Click **OK** again and you return to the **IBM Key Management** screen. You can either perform other tasks or exit the tool.

#### *Creating IKE tunnels using digital certificates:*

To create IKE tunnels that use digital certificates, you must use Web-based System Manager and the Key Manager tool.

To enable the use of digital certificates when defining the key management IKE tunnel policies, you must configure a transform that uses signature mode. Signature mode uses an RSA signature algorithm for authentication. IP Security provides the Web-based System Manager dialog "Add/Change a Transform" to allow you to select an authentication method of RSA Signature or RSA Signature with CRL Checking.

At least one endpoint of the tunnel must have a policy defined that uses a signature mode transform. You can also define other transforms using signature mode through Web-based System Manager.

The IKE key management tunnel types (the **Host Identity Type** field on the **Identification** tab) supported by IP Security are as follows:

- IP address
- Fully Qualified Domain Name (FQDN)
- *user@FQDN*
- X.500 Distinguished Name
- Key identifier

Use **Web-based System Manager** to select host-identity types on the **Key Management Tunnel Properties - Identification** tab. If you select **IP Address**, **FQDN**, or **user@FQDN**, you must enter values in Web-based System Manager and then provide these values to the CA. This information is used as the Subject Alternate Name in the personal digital certificate.

For example, if you choose a host identity type of X.500 Distinguished Name from the Web-based System Manager list on the **Identification** tab, and you enter the host identity as **/C=US/O=ABC/OU=SERV/CN=name.austin.ibm.com**, the following are the values that you must enter in Key Manager when creating a digital certificate request:

- Common name: **name.austin.ibm.com**
- Organization: **ABC**
- Organizational unit: **SERV**
- Country : **US**

The X.500 Distinguished Name entered is the name set up by your system or LDAP administrator. Entering an organizational unit value is optional. The CA then uses this information when creating the digital certificate.

For another example, if you choose a host identity type of **IP Address** from the list, and you enter the host identity as **10.10.10.1**, the following are the values you must enter in the digital certificate request:

- Common name: **name.austin.ibm.com**
- Organization: **ABC**
- Organizational unit: **SERV**
- Country : **US**
- Subject alternate IP address field: **10.10.10.1**

After you create the digital certificate request with this information, the CA uses this information to create the personal digital certificate.

When requesting a personal digital certificate, the CA needs the following information:

- You are requesting a X.509 certificate.
- The signature format is MD5 with RSA encryption.
- Whether you are specifying Subject Alternate Name. Alternate name types are:
  - IP address
  - Fully qualified domain name (FQDN)



– *user@FQDN*

The following subject alternate-name information is included in the certificate request file.

- Your planned key use (the digital signature bit must be selected).
- The Key Manager digital certificate request file (in PKCS#10 format).

For specific steps using the Key Manager tool to create a certificate request, see “Requesting a digital certificate” on page 237.

Before activating the IKE tunnel, you must add the personal digital certificate you received from the CA into the Key Manager database, **ikekey.kdb**. For more information, see “Adding (Receiving) a new digital certificate” on page 238.

IP Security supports the following types of personal digital certificates:

### **Subject DN**

The Subject Distinguished Name must be in the following format and order:

```
/C=US/O=ABC/OU=SERV/CN=name.austin.ibm.com
```

The Key Manager tool allows only one **OU** value.

### **Subject DN and Subject Alternate Name as an IP address**

The Subject Distinguished Name and Subject Alternate Name can be designated as an IP address, as shown in the following:

```
/C=US/O=ABC/OU=SERV/CN=name.austin.ibm.com and 10.10.10.1
```

### **Subject DN and Subject Alternate Name as FQDN**

The Subject Distinguished Name and Subject Alternate Name can be designated as a fully qualified domain name, as shown in the following:

```
/C=US/O=ABC/OU=SERV/CN=name.austin.ibm.com and bell.austin.ibm.com.
```

### **Subject DN and Subject Alternate Name as *user@FQDN***

The Subject Distinguished Name and Subject Alternate Name can be designated as a user address (*user\_ID@fully\_qualified\_domain\_name*), as shown in the following:

```
/C=US/O=ABC/OU=SERV/CN=name.austin.ibm.com and name@austin.ibm.com.
```

### **Subject DN and multiple Subject Alternate Names**

The Subject Distinguished Name can be associated with multiple Subject Alternate Names, as shown in the following:

```
/C=US/O=ABC/OU=SERV/CN=name.austin.ibm.com and bell.austin.ibm.com, 10.10.10.1, and user@name.austin.ibm.com.
```

## **Network address translation**

IP Security can use devices whose addresses undergo network address translation (NAT).

NAT is widely used as part of firewall technology for Internet-connection sharing, and it is a standard feature on routers and edge devices. The IP Security protocol depends on identifying remote endpoints and their policy based on the remote IP address. When intermediate devices such as routers and firewalls translate a private address to a public address, the required authentication processing in IP Security might fail because the address in the IP packet has been modified after the authentication digest was calculated. With the new IP Security NAT support, devices that are configured behind a node that performs network address translation are able to establish an IP Security Tunnel. The IP Security code is able to detect when a remote address has been translated. Using the new IP Security implementation with support for NAT allows a VPN client to connect from home or on the road to the office through an internet connection with NAT enabled.

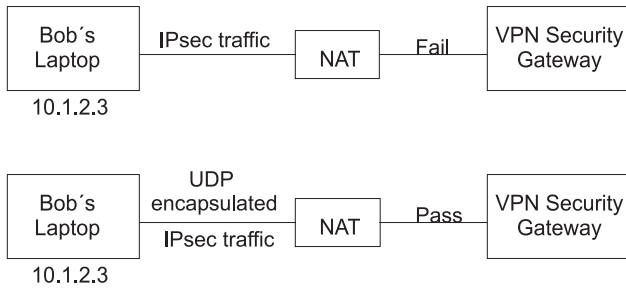

Figure 12. NAT-enabled IP Security

This diagram shows the difference between a NAT-enabled IP Security implementation, with UDP encapsulated traffic and an implementation that is not NAT-enabled.

### Configuring IP security to work with NAT:

In order to use NAT in IP Security, you must set the `ENABLE_IPSEC_NAT_TRAVERSAL` variable in the `/etc/isakmpd.conf` file. When this variable is set, filter rules are added to send and receive traffic on port 4500.

The following example shows the filter rules when the `ENABLE_IPSEC_NAT_TRAVERSAL` variable is set.

Dynamic rule 2:

```

Rule action : permit
Source Address : 0.0.0.0 (any)
Source Mask : 0.0.0.0 (any)
Destination Address : 0.0.0.0 (any)
Destination Mask : 0.0.0.0 (any)
Source Routing : no
Protocol : udp
Source Port : 0 (any)
Destination Port : 4500
Scope : local
Direction : inbound
Fragment control : all packets
Tunnel ID number : 0

```

Dynamic rule 3:

```

Rule action : permit
Source Address : 0.0.0.0 (any)
Source Mask : 0.0.0.0 (any)
Destination Address : 0.0.0.0 (any)
Destination Mask : 0.0.0.0 (any)
Source Routing : no
Protocol : udp
Source Port : 4500
Destination Port : 0 (any)
Scope : local
Direction : outbound
Fragment control : all packets
Tunnel ID number : 0

```

Setting the `ENABLE_IPSEC_NAT_TRAVERSAL` variable also adds some additional filter rules in the filter table. Special IPSEC NAT messages use UDP encapsulation and filter rules must be added to allow this traffic to flow. In addition, in phase 1 signature mode is required. If IP Address is used as the identifier in the certificate, it should contain the private ip address.

IP Security also needs to send NAT keep alive messages to maintain the mapping of the original IP Address and the NAT address. The interval is specified by the `NAT_KEEPALIVE_INTERVAL` variable in

`/etc/isakmpd.conf` file. This variable specifies how frequently NAT keepalive packets are sent in seconds. If you do not specify a value for `NAT_KEEPALIVE_INTERVAL`, a default value of 20 seconds is used.

### **Limitations when using NAT exchanges:**

Endpoints behind NAT devices must protect their traffic using the ESP protocol.

ESP is the predominate header selected for IP Security, and will be usable for most customer applications. ESP includes hashing of the user data, but not of the IP Header. The integrity checking in the AH header incorporates the IP source and destination addresses in the keyed message integrity check. NAT or reverse NAT devices that make changes to the address fields invalidate the message integrity check. Therefore, if only the AH protocol is defined in the phase 2 policy for a tunnel, and NAT is detected in a phase 1 exchange, a Notify Payload saying `NO_PROPOSAL_CHOSEN` is sent.

Additionally, a connection using NAT must select tunnel mode so that the original IP address is encapsulated in the packet. Transport mode and addresses with NAT are not compatible. If a NAT is detected and only transport mode is proposed in phase 2, a Notify Payload saying `NO_PROPOSAL_CHOSEN` is sent.

### **Avoiding tunnel mode conflicts:**

Remote peers might negotiate entries that overlap in a gateway. This overlap causes a tunnel mode conflict.

The following figure shows a tunnel mode conflict.

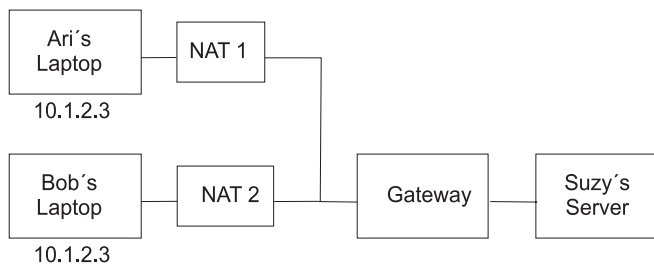

Figure 13. Tunnel Mode Conflict

The gateway has two possible Security Associations (SAs) for the 10.1.2.3 IP address. These duplicate remote addresses cause confusion over where to send packets coming from the server. When a tunnel is configured between Suzy's server and Ari's laptop, the IP address is used, and Suzy cannot configure a tunnel with Bob with the same IP address. To avoid a tunnel mode conflict, you should not define a tunnel with the same IP address. Because the remote address is not under the control of the remote user, other ID types should be used to identify the remote host such as fully qualified domain name or user at fully qualified domain name.

## **Configuring manual tunnels**

The following procedures configure IP Security to use manual tunnels.

### **Setting up tunnels and filters:**

The process of setting up a tunnel is to define the tunnel on one end, import the definition on the other end, and activate the tunnel and filter rules on both ends. The tunnel is then ready to use.

To set up a manual tunnel, it is not necessary to separately configure the filter rules. As long as all traffic between two hosts goes through the tunnel, the necessary filter rules are automatically generated.

Information about the tunnel must be made to match on both sides if it is not explicitly supplied. For instance, the encryption and authentication algorithms specified for the source will be used for the destination if the destination values are not specified.

### **Removing filters:**

To completely remove filters and stop IP security, use the **rmdev** command.

The default filter rule is still active even if filtering is turned off with the **mkfilt -d** command. This command allows you to suspend or remove all filters rules and load new rules while the protection of the default rule remains. The default filter rule is *DENY*. If you deactivate filtering with the **mkfilt -d** command, reports from the **lsfilt** command will show that filtering is turned off, but no packets being allowed in or out. If you want to stop IP security entirely, use the **rmdev** command.

### **Creating a manual tunnel on the first host:**

You can configure a tunnel using the Web-based System Manager Network application, the **SMITips4\_basic** fast path (for IP Version 4), the **SMIT ips6\_basic** fast path (for IP version 6) or you can create the tunnel manually using the following procedure.

The following is a sample of the **gentun** command used to create a manual tunnel:

```
gentun -v 4 -t manual -s 5.5.5.19 -d 5.5.5.8 \
-a HMAC_MD5 -e DES_CBC_8 -N 23567
```

You can use the **lstun -v 4** command to list the characteristics of the manual tunnel created by the previous example. The output looks similar to the following example:

```
Tunnel ID : 1
IP Version : IP Version 4
Source : 5.5.5.19
Destination : 5.5.5.8
Policy : auth/encr
Tunnel Mode : Tunnel
Send AH Algo : HMAC_MD5
Send ESP Algo : DES_CBC_8
Receive AH Algo : HMAC_MD5
Receive ESP Algo : DES_CBC_8
Source AH SPI : 300
Source ESP SPI : 300
Dest AH SPI : 23576
Dest ESP SPI : 23576
Tunnel Life Time : 480
Status : Inactive
Target : -
Target Mask : -
Replay : No
New Header : Yes
Snd ENC-MAC Algo : -
Rcv ENC-MAC Algo : -
```

To activate the tunnel, type the following code:

```
mktun -v 4 -t1
```

The filter rules associated with the tunnel are automatically generated.

To view the filter rules, use the **lsfilt -v 4** command. The output looks similar to the following example:

```
Rule 4:
Rule action : permit
Source Address : 5.5.5.19
Source Mask : 255.255.255.255
Destination Address : 5.5.5.8
```

```
Destination Mask : 255.255.255.255
Source Routing : yes
Protocol : all
Source Port : any 0
Destination Port : any 0
Scope : both
Direction : outbound
Logging control : no
Fragment control : all packets
Tunnel ID number : 1
Interface : all
Auto-Generated : yes
```

```
Rule 5:
Rule action : permit
Source Address : 5.5.5.8
Source Mask : 255.255.255.255
Destination Address : 5.5.5.19
Destination Mask : 255.255.255.255
Source Routing : yes
Protocol : all
Source Port : any 0
Destination Port : any 0
Scope : both
Direction : inbound
Logging control : no
Fragment control : all packets
Tunnel ID number : 1
Interface : all
Auto-Generated : yes
```

To activate the filter rules, including the default filter rules, use the **mktun -v 4 -t 1** command.

To set up the other side (when it is another machine using this operating system), the tunnel definition can be exported on host A and then imported to host B.

The following command exports the tunnel definition into a file named **ipsec\_tun\_manu.exp** and any associated filter rules to the file **ipsec\_fltr\_rule.exp** in the directory indicated by the **-f** flag:

```
exptun -v 4 -t 1 -f /tmp
```

### ***Creating a manual tunnel on the second host:***

To create the matching end of the tunnel, the export files are copied and imported into the remote machine.

Use the following command to create the matching end of the tunnel:

```
imptun -v 4 -t 1 -f /tmp
```

where

**1** Is the tunnel to be imported

**/tmp** Is the directory where the import files reside

The tunnel number is generated by the system. You can obtain it from the output of the **gentun** command or by using the **lstun** command to list the tunnels and determine the correct tunnel number to import. If there is only one tunnel in the import file, or if all the tunnels are to be imported, the **-t** option is not needed.

If the remote machine is not running this operating system, the export file can be used as a reference for setting up the algorithm, keys, and security parameters index (SPI) values for the other end of the tunnel.

Export files from a firewall product can be imported to create tunnels. To do this, use the **-n** option when importing the file, as follows:

```
imptun -v 4 -f /tmp -n
```

## IP security filter configuration

Filtering can be set up to be simple, using mostly autogenerated filter rules, or can be customized by defining very specific filter functions based on the properties of the IP packets.

Each line in a filter table is known as a *rule*. A collection of rules determine what packets are accepted in and out of the machine and how they are directed. Matches to filter rules on incoming packets are done by comparing the source address and SPI value to those listed in the filter table. Therefore, this pair must be unique. Filter rules can control many aspects of communications, including source and destination addresses and masks, protocol, port number, direction, fragment control, source routing, tunnel, and interface type.

The types of filter rules are as follows:

- Static filter rules are created in the filter table to be used for the general filtering of traffic or for associating with manual tunnels. They can be added, deleted, modified, and moved. An optional description text field can be added to identify a specific rule.
- Autogenerated filter rules and user-specified filter rules (also called *autogenerated* filter rules) are a specific set of rules created for use of IKE tunnels. Both static and dynamic filter rules are created based on data management tunnel information and on data management tunnel negotiation.
- Predefined filter rules are generic filter rules that cannot be modified, moved, or deleted, such as the all traffic rule, the ah rule, and the esp rule. They pertain to all traffic.

The direction flag (**-w**) of the **genfilt** command is used to specify when the specified rule should be used either during input packet processing or output packet processing. When the **both** value for this flag is used, it specifies that this rule is used during both input and output processing. In AIX IPsec, when filtering is turned on, at least one rule determines the fate of any network packet (be it incoming or outgoing). If you want a rule to be used only during processing of an incoming packet (or outgoing packet), you can choose to do so by using the **-w** switch of the **genfilt** command. For example, when a packet is sent out from host A to host B, the outgoing IP packet has the source address of A and the destination address of B. On host A, this packet is processed by the IPsec filter during the outbound processing and during the inbound processing on host B. Assume there is a gateway G between host A and host B. On gateway G, this same packet (all the immutable fields having the same value) is processed twice: once for the inbound processing and once for the outbound processing (if the **ipforwarding** option is set). For the packet to travel from host A to host B through gateway G, you need a permit rule with:

- On host A – **src addr** set to A, **dest addr** to B, direction to outbound
- On host B – **src addr** set to A, **dest addr** to B, direction to inbound

But on the gateway G, you will be requiring two rules:

1. **src addr** set to A, **dest addr** to B, direction to outbound
2. **src addr** set to A, **dest addr** to B, direction to inbound

The above rules can be replaced by: **src addr** set to A, **dest addr** to B and direction to both. Therefore, the value of **both** for direction is typically used in gateways that have the **ipforwarding** option set to no. The above configuration is only for the packets travelling from host A to host B through the gateway G. If you want the packets to travel in the reverse direction (from host B to host A through the gateway G), then you need another rule for that.

**Note:** Direction **both** implies that the associated rule is used for both incoming and outgoing packets. However, it doesn't mean that the rule is applied when the source and destination addresses are reversed. For instance, if server A has a rule with A as source address and B as destination

address and the direction is set to **both**, then *A* as incoming packet with *B* as source address and *A* as destination does not match this rule. Typically the **both** option is used in gateways that forward the packets.

Associated with these filter rules are Subnet masks, which group IDs that are associated with a filter rule, and the host-firewall-host configuration option. The following sections describe the different types of filter rules and their associated features.

### ***IP filters for AIX:***

IPFilter is a software package that can be used to provide network address translation (NAT) or firewall services.

IPFilter version 4.1.13 open source software has been ported to AIX, consistent with the licensing presented on the IP Filter website (<http://coombs.anu.edu.au/~avalon/>). The IPFilter software is shipped on the AIX 5.3 expansion pack, beginning with AIX 5L Version 5.3 with the 5300-05 Technology Level. The installp package, ipfl, includes the man page and license.

On AIX, the IPFilter product loads as a kernel extension, `/usr/lib/drivers/ipf`. The **ipf**, **ipfs**, **ipfstat**, **ipmon**, and **ipnat** binaries are also shipped with this package.

After installing the package, run the following command to load the kernel extension:

```
/usr/lib/methods/cfg_ipf -l
```

Run the following command to unload the kernel extension:

```
/usr/lib/methods/cfg_ipf -u
```

Remember to enable ipforwarding (network option) if packet forwarding is needed. For more information about IPFilter, including man pages and an FAQ, check the IPFilter website (<http://coombs.anu.edu.au/~avalon/>).

### ***Static filter rules:***

Each static filter rule contains space-separated fields.

The following list provides the name of each field in a static filter rule followed by an example from rule 1 in parentheses:

- Rule\_number (1)
- Action (permit)
- Source\_addr (0.0.0.0)
- Source\_mask (0.0.0.0)
- Dest\_addr (0.0.0.0)
- Dest\_mask (0.0.0.0)
- Source\_routing (no)
- Protocol (udp)
- Srcprt\_operator (eq)
- Srcprt\_value (4001)
- Dstprt\_operator (eq)
- Dstprt\_value (4001)
- Scope (both)
- Direction (both)
- Logging (no)

- Fragment (all packets)
- Tunnel (0)
- Interface (all).

### Example of static filter rules

```

1 permit 0.0.0.0 0.0.0.0 0.0.0.0 0.0.0.0 no udp eq 4001 eq 4001 both both no all
 packets 0 all

2 permit 0.0.0.0 0.0.0.0 0.0.0.0 0.0.0.0 no ah any 0 any 0 both both no all packets
 0 all

3 permit 0.0.0.0 0.0.0.0 0.0.0.0 0.0.0.0 no esp any 0 any 0 both both no all packets
 0 all

4 permit 10.0.0.1 255.255.255.255 10.0.0.2 255.255.255.255 no all any 0 any 0 both
 outbound no all packets 1 all outbound traffic

5 permit 10.0.0.2 255.255.255.255 10.0.0.1 255.255.255.255 no all any 0 any 0 both
 inbound no all packets 1 all

6 permit 10.0.0.1 255.255.255.255 10.0.0.3 255.255.255.255 no tcp lt 1024 eq 514 local
 outbound yes all packets 2 all

7 permit 10.0.0.3 255.255.255.255 10.0.0.1 255.255.255.255 no tcp/ack eq 514 lt 1024
 local inbound yes all packets 2 all

8 permit 10.0.0.1 255.255.255.255 10.0.0.3 255.255.255.255 no tcp/ack lt 1024 lt 1024
 local outbound yes all packets 2 all

9 permit 10.0.0.3 255.255.255.255 10.0.0.1 255.255.255.255 no tcp lt 1024 lt 1024 local
 inbound yes all packets 2 all

10 permit 10.0.0.1 255.255.255.255 10.0.0.4 255.255.255.255 no icmp any 0 any 0 local
 outbound yes all packets 3 all

11 permit 10.0.0.4 255.255.255.255 10.0.0.1 255.255.255.255 no icmp any 0 any 0 local
 inbound yes all packets 3 all

12 permit 10.0.0.1 255.255.255.255 10.0.0.5 255.255.255.255 no tcp gt 1023 eq 21 local
 outbound yes all packets 4 all

13 permit 10.0.0.5 255.255.255.255 10.0.0.1 255.255.255.255 no tcp/ack eq 21 gt 1023 local
 inbound yes all packets 4 all

14 permit 10.0.0.5 255.255.255.255 10.0.0.1 255.255.255.255 no tcp eq 20 gt 1023 local
 inbound yes all packets 4 all

15 permit 10.0.0.1 255.255.255.255 10.0.0.5 255.255.255.255 no tcp/ack gt 1023 eq 20 local
 outbound yes all packets 4 all

16 permit 10.0.0.1 255.255.255.255 10.0.0.5 255.255.255.255 no tcp gt 1023 gt 1023 local
 outbound yes all packets 4 all

```



```
17 permit 10.0.0.5 255.255.255.255 10.0.0.1 255.255.255.255 no tcp/ack gt 1023 gt 1023 local
inbound yes all packets 4 all
```

```
18 permit 0.0.0.0 0.0.0.0 0.0.0.0 0.0.0.0 no all any 0 any 0 both both yes all
packets
```

Each rule in the previous example is described as follows:

#### Rule 1

For the **Session Key** daemon. This rule only appears in IP Version 4 filter tables. It uses port number 4001 to control packets for refreshing the session key. Rule 1 an example of how the port number can be used for a specific purpose.

**Note:** Do not modify this filter rule, except for logging purposes.

#### Rules 2 and 3

Allow processing of authentication headers (AH) and encapsulating security payload (ESP) headers.

**Note:** Do not modify Rules 2 and 3, except for logging purposes.

#### Rules 4 and 5

Set of autogenerated rules that filter traffic between addresses 10.0.0.1 and 10.0.0.2 through tunnel 1. Rule 4 is for outbound traffic, and rule 5 is for inbound traffic.

**Note:** Rule 4 has a user-defined description of *outbound traffic*.

#### Rules 6 through 9

Set of user-defined rules that filter outbound rsh, rcp, rdump, rrestore, and rdist services between addresses 10.0.0.1 and 10.0.0.3 through tunnel 2. In this example, logging is set to Yes, so that the administrator can monitor this type of traffic.

#### Rules 10 and 11

Set of user-defined rules that filter both inbound and outbound icmp services of any type between addresses 10.0.0.1 and 10.0.0.4 through tunnel 3.

#### Rules 12 through 17

User-defined filter rules that filter outbound file transfer protocol (FTP) service from 10.0.0.1 and 10.0.0.5 through tunnel 4.

#### Rule 18

Autogenerated rule always placed at the end of the table. In this example, it permits all packets that do not match the other filter rules. It can be set to deny all traffic not matching the other filter rules.

Each rule can be viewed separately (using **lsfilt**) to list each field with its value. For example:

```
Rule 1:
Rule action : permit
Source Address : 0.0.0.0
Source Mask : 0.0.0.0
Destination Address : 0.0.0.0
Destination Mask : 0.0.0.0
Source Routing : yes
Protocol : udp
Source Port : eq 4001
Destination Port : eq 4001
Scope : both
Direction : both
Logging control : no
```

```

Fragment control : all packets
Tunnel ID number : 0
Interface : all
Auto-Generated : yes

```

The following list contains all the parameters that can be specified in a filter rule:

```

-v IP Version: 4 or 6.
-a Action:
 d Deny
 p Permit
-s Source address. Can be an IP address or hostname.
-m Source subnet mask.
-d Destination address. Can be an IP address or hostname.
-M Destination subnet mask.
-g Source routing control: y or n.
-c Protocol. Values can be udp, icmp, tcp, tcp/ack, ospf, pip, esp, ah and all.
-o Source port or ICMP type operation.
-p Source port or ICMP type value.
-O Destination port or ICMP code operation.
-P Destination port or ICMP code value.
-r Routing:
 r Forwarded packets.
 l Local destined/originated packets.
 b Both.
-l Log control.
 y Include in log.
 n Do not include in log.
-f Fragmentation.
 y Applies to fragments headers, fragments, and non-fragments.
 o Applies only to fragments and fragment headers.
 n Applies only to non-fragments.
 h Applies only to non-fragments and fragment headers.
-t Tunnel ID.
-i Interface, such as tr0 or en0.

```

For more information, see the **genfilt** and **chfilt** command descriptions.

### ***Autogenerated filter rules and user-specified filter rules:***

Certain rules are autogenerated for the use of the IP Security filter and tunnel code.

Autogenerated rules include:

- Rules for the session key daemon that refresh the IP version 4 keys in IKE (AIX 4.3.3 and later)
- Rules for the processing of AH and ESP packets.

Filter rules are also autogenerated when defining tunnels. For manual tunnels, autogenerated rules specify the source and destination addresses and the mask values, as well as the tunnel ID. All traffic between those addresses will flow through the tunnel.

For IKE tunnels, autogenerated filter rules determine protocol and port numbers during IKE negotiation. The IKE filter rules are kept in a separate table, which is searched after the static filter rules and before the autogenerated rules. IKE filter rules are inserted in a default position within the static filter table, but they can be moved by the user.

Autogenerated rules permit all traffic over the tunnel. User-defined rules can place restrictions on certain types of traffic. Place these user-defined rules before the autogenerated rules, because IP Security uses the first rule it finds that applies to the packet. The following is an example of user-defined filter rules that filter traffic based on ICMP operation.

```
1 permit 10.0.0.1 255.255.255.255 10.0.0.4 255.255.255.255 no icmp any 8 any 0
 local outbound no all packets 3 all
2 permit 10.0.0.4 255.255.255.255 10.0.0.1 255.255.255.255 no icmp any 0 any 0 local
 inbound no all packets 3 all
3 permit 10.0.0.4 255.255.255.255 10.0.0.1 255.255.255.255 no icmp any 8 any 0 local
 inbound no all packets 3 all
4 permit 10.0.0.1 255.255.255.255 10.0.0.4 255.255.255.255 no icmp any 0 any 0 local
 outbound no all packets 3 all
```

To simplify the configuration of a single tunnel, filter rules are autogenerated when tunnels are defined. This function can be suppressed by specifying the **-g** flag in the **gentun**. You can find a sample filter file with **genfilt** commands to generate filter rules for different TCP/IP services in **/usr/samples/ipsec/filter.sample**.

**Predefined filter rules:**

Several predefined filter rules are autogenerated with certain events.

When the `ipsec_v4` or `ipsec_v6` device is loaded, a predefined rule is inserted into the filter table and then activated. By default, this predefined rule is to permit all packets, but it is user-configurable and you can set it to deny all packets.

**Note:** When configuring remotely, ensure that the deny rule is not enabled before the configuration is complete, to prevent your session from getting locked out of the machine. The situation can be avoided either by setting the default action to permit or by configuring a tunnel to the remote machine before activating IP Security.

Both IP Version 4 and IP Version 6 filter tables have a predefined rule. Either may be independently changed to deny all. This will keep traffic from passing unless that traffic is specifically defined by additional filter rules. The only other option to change on the predefined rules is **chfilt** with the **-l** option, which allows packets matching that rule to be logged.

To support IKE tunnels, a dynamic filter rule is placed in the IP Version 4 filter table. This is the position at which dynamic filter rules are inserted into the filter table. This position can be controlled by the user by moving its position up and down the filter table. After the tunnel manager daemon and **isakmpd** daemon are initialized to allow IKE tunnels to be negotiated, rules are automatically created in the dynamic filter table to handle IKE messages as well as AH and ESP packets.

**Subnet masks:**

Subnet masks are used to group a set of IDs that are associated with a filter rule. The mask value is ANDed with the ID in the filter rules and compared to the ID specified in the packet.

For example, a filter rule with a source IP address of 10.10.10.4 and a subnet mask of 255.255.255.255 specified that an exact match must occur of the decimal IP address, as shown in the following:

|                   | Binary              | Decimal    |
|-------------------|---------------------|------------|
| Source IP address | 1010.1010.1010.0100 | 10.10.10.4 |

|             | Binary                              | Decimal         |
|-------------|-------------------------------------|-----------------|
| Subnet mask | 11111111.11111111.11111111.11111111 | 255.255.255.255 |

A 10.10.10.x subnet is specified as 11111111.11111111.11111111.0 or 255.255.255.0. An incoming address would have the subnet mask applied to it, then the combination would be compared to the ID in the filter rule. For example, an address of 10.10.10.100 becomes 10.10.10.0 after the subnet mask is applied, which matches the filter rule.

A subnet mask of 255.255.255.240 allows any value for the last four bits in the address.

### Host-firewall-host configuration:

The host-firewall-host configuration option for tunnels allows you to create a tunnel between your host and a firewall, then automatically generate the necessary filter rules for correct communication between your host and a host behind the firewall.

The autogenerated filter rules permit all rules between the two non-firewall hosts over the tunnel specified. The default rules—for user datagram protocol (UDP), Authentication Headers (AH), and Encapsulating Security Payload (ESP) headers—should already handle the host to firewall communication. The firewall will have to be configured appropriately to complete the setup. You should use the export file from the tunnel you created to enter the SPI values and keys that the firewall needs.

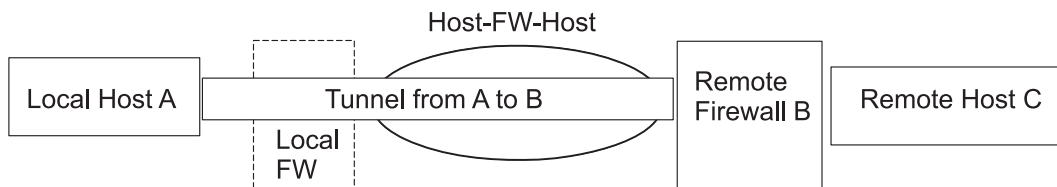

Figure 14. Host-Firewall-Host

This illustration shows a Host-Firewall-Host configuration. Host A has a tunnel running through a local firewall and out to the internet. Then it goes to Remote Firewall B, and then on to Remote Host C.

### Logging facilities

As hosts communicate with each other, the transferred packets may be logged to the system log daemon, **syslogd**. Other important messages about IP Security also display.

An administrator may choose to monitor this logging information for traffic analysis and debugging assistance. The following are the steps for setting up the logging facilities.

1. Edit the **/etc/syslog.conf** file to add the following entry:

```
local4.debug var/adm/ipsec.log
```

Use the local4 facility to record traffic and IP Security events. Standard operating system priority levels apply. You should set the priority level of debug until traffic through IP Security tunnels and filters show stability and proper movement.

**Note:** The logging of filter events can create significant activity at the IP Security host and can consume large amounts of storage.

2. Save the **/etc/syslog.conf** file.
3. Go to the directory you specified for the log file and create an empty file with the same name. In the case above, you would change to **/var/adm** directory and issue the command:

```
touch ipsec.log
```

4. Issue a **refresh** command to the **syslogd** subsystem:  

```
refresh -s syslogd
```
5. If you are using IKE tunnels, ensure the **/etc/isakmpd.conf** file specifies the desired **isakmpd** logging level. (See “Internet Protocol security problem diagnosis” on page 257 for more information on IKE logging.)
6. While creating filter rules for your host, if you would like packets matching a specific rule to be logged, set the **-l** parameter for the rule to **Y** (Yes) using the **genfilt** or the **chfilt** commands.
7. Turn on packet logging and start the **ipsec\_logd** daemon using the command:  

```
mkfilt -g start
```

You can stop packet logging by issuing the following command:  

```
mkfilt -g stop
```

The following sample log file contains traffic entries and other IP Security log entries:

1. Aug 27 08:08:40 host1 : Filter logging daemon ipsec\_logd (level 2.20) initialized at 08:08:40 on 08/27/97A
2. Aug 27 08:08:46 host1 : mkfilt: Status of packet logging set to Start at 08:08:46 on 08/27/97
3. Aug 27 08:08:47 host1 : mktun: Manual tunnel 2 for IPv4, 9.3.97.244, 9.3.97.130 activated.
4. Aug 27 08:08:47 host1 : mkfilt: #:1 permit 0.0.0.0 0.0.0.0 0.0.0.0 0.0.0.0 udp eq 4001 eq 4001 both both l=n f=y t=0 e= a=
5. Aug 27 08:08:47 host1 : mkfilt: #:2 permit 0.0.0.0 0.0.0.0 0.0.0.0 0.0.0.0 ah any 0 any 0 both both l=n f=y t=0 e= a=
6. Aug 27 08:08:47 host1 : mkfilt: #:3 permit 0.0.0.0 0.0.0.0 0.0.0.0 0.0.0.0 esp any 0 any 0 both both l=n f=y t=0 e= a=
7. Aug 27 08:08:47 host1 : mkfilt: #:4 permit 10.0.0.1 255.255.255.255 10.0.0.2 255.255.255.255 icmp any 0 any 0 local outbound l=y f=y t=1 e= a=
8. Aug 27 08:08:47 host1 : mkfilt: #:4 permit 10.0.0.2 255.255.255.255 10.0.0.1 255.255.255.255 icmp any 0 any 0 local inbound l=y f=y t=1 e= a=
9. Aug 27 08:08:47 host1 : mkfilt: #:6 permit 0.0.0.0 0.0.0.0 0.0.0.0 0.0.0.0 all any 0 any 0 both both l=y f=y t=0 e= a=
10. Aug 27 08:08:47 host1 : mkfilt: Filter support (level 1.00) initialized at 08:08:47 on 08/27/97
11. Aug 27 08:08:48 host1 : #:6 R:p o:10.0.0.1 s:10.0.0.1 d:10.0.0.20 p:udp sp:3327 dp:53 r:l a:n f:n T:0 e:n l:67
12. Aug 27 08:08:48 host1 : #:6 R:p i:10.0.0.1 s:10.0.0.20 d:10.0.0.1 p:udp sp:53 dp:3327 r:l a:n f:n T:0 e:n l:133
13. Aug 27 08:08:48 host1 : #:6 R:p i:10.0.0.1 s:10.0.0.15 d:10.0.0.1 p:tcp sp:4649 dp:23 r:l a:n f:n T:0 e:n l:43
14. Aug 27 08:08:48 host1 : #:6 R:p o:10.0.0.1 s:10.0.0.1 d:10.0.0.15 p:tcp sp:23 dp:4649 r:l a:n f:n T:0 e:n l:41
15. Aug 27 08:08:48 host1 : #:6 R:p i:10.0.0.1 s:10.0.0.15 d:10.0.0.1 p:tcp sp:4649 dp:23 r:l a:n f:n T:0 e:n l:40
16. Aug 27 08:08:51 host1 : #:4 R:p o:10.0.0.1 s:10.0.0.1 d:10.0.0.2 p:icmp t:8 c:0 r:l a:n f:n T:1 e:n l:84
17. Aug 27 08:08:51 host1 : #:5 R:p i:10.0.0.1 s:10.0.0.2 d:10.0.0.1 p:icmp t:0 c:0 r:l a:n f:n T:1 e:n l:84
18. Aug 27 08:08:52 host1 : #:4 R:p o:10.0.0.1 s:10.0.0.1 d:10.0.0.2 p:icmp t:8 c:0 r:l a:n f:n T:1 e:n l:84
19. Aug 27 08:08:52 host1 : #:5 R:p i:10.0.0.1 s:10.0.0.2 d:10.0.0.1 p:icmp t:0 c:0 r:l a:n f:n T:1 e:n l:84
20. Aug 27 08:32:27 host1 : Filter logging daemon terminating at 08:32:27 on 08/27/971

The following paragraphs explain the log entries.

- 1 Filter logging daemon activated.
- 2 Filter packet logging set to on with the **mkfilt -g start** command.
- 3 Tunnel activation, showing tunnel ID, source address, destination address, and time stamp.
- 4-9 Filters have been activated. Logging shows all loaded filter rules.

- 10 Message showing activation of filters.
- 11-12 These entries show a DNS lookup for a host.
- 13-15 These entries show a partial Telnet connection (the other entries have been removed from this example for space reasons).
- 16-19 These entries show two pings.
- 20 Filter logging daemon shutting down.

The following example shows two hosts negotiating a phase 1 and a phase 2 tunnel from the initiating host's point of view. (The **isakmpd** logging level has been specified as **isakmp\_events**.)

1. Dec 6 14:34:42 host1 Tunnel Manager: 0: TM is processing a Connection\_request\_msg
2. Dec 6 14:34:42 host1 Tunnel Manager: 1: Creating new P1 tunnel object (tid)
3. Dec 6 14:34:42 host1 isakmpd: 192.168.100.103 >>> 192.168.100.104 ( SA PROPOSAL TRANSFORM )
4. Dec 6 14:34:42 host1 isakmpd: ::ffff:192.168.100.103 <<< 192.168.100.104 ( SA PROPOSAL TRANSFORM )
5. Dec 6 14:34:42 host1 isakmpd: Phase I SA Negotiated
6. Dec 6 14:34:42 host1 isakmpd: 192.168.100.103 >>> 192.168.100.104 ( KE NONCE )
7. Dec 6 14:34:42 host1 isakmpd: ::ffff:192.168.100.103 <<< 192.168.100.104 ( KE NONCE )
8. Dec 6 14:34:42 host1 isakmpd: Encrypting the following msg to send: ( ID HASH )
9. Dec 6 14:34:42 host1 isakmpd: 192.168.100.103 >>> 192.168.100.104 ( Encrypted Payloads )
10. Dec 6 14:34:42 host1 isakmpd: ::ffff:192.168.100.103 <<< 192.168.100.104 ( Encrypted Payloads )
11. Dec 6 14:34:42 host1 Tunnel Manager: 1: TM is processing a P1\_sa\_created\_msg (tid)
12. Dec 6 14:34:42 host1 Tunnel Manager: 1: Received good P1 SA, updating P1 tunnel (tid)
13. Dec 6 14:34:42 host1 Tunnel Manager: 0: Checking to see if any P2 tunnels need to start
14. Dec 6 14:34:42 host1 isakmpd: Decrypted the following received msg: ( ID HASH )
15. Dec 6 14:34:42 host1 isakmpd: Phase I Done !!!
16. Dec 6 14:34:42 host1 isakmpd: Phase I negotiation authenticated
17. Dec 6 14:34:44 host1 Tunnel Manager: 0: TM is processing a Connection\_request\_msg
18. Dec 6 14:34:44 host1 Tunnel Manager: 0: Received a connection object for an active P1 tunnel
19. Dec 6 14:34:44 host1 Tunnel Manager: 1: Created blank P2 tunnel (tid)
20. Dec 6 14:34:44 host1 Tunnel Manager: 0: Checking to see if any P2 tunnels need to start
21. Dec 6 14:34:44 host1 Tunnel Manager: 1: Starting negotiations for P2 (P2 tid)
22. Dec 6 14:34:45 host1 isakmpd: Encrypting the following msg to send: ( HASH SA PROPOSAL TRANSFORM NONCE ID ID )
23. Dec 6 14:34:45 host1 isakmpd: 192.168.100.103 >>> 192.168.100.104 ( Encrypted Payloads )
24. Dec 6 14:34:45 host1 isakmpd: ::ffff:192.168.100.103 <<< 192.168.100.104 ( Encrypted Payloads )
25. Dec 6 14:34:45 host1 isakmpd: Decrypted the following received msg: ( HASH SA PROPOSAL TRANSFORM NONCE ID ID )
26. Dec 6 14:34:45 host1 isakmpd: Encrypting the following msg to send: ( HASH )
27. Dec 6 14:34:45 host1 isakmpd: 192.168.100.103 >>> 192.168.100.104 ( Encrypted Payloads )
28. Dec 6 14:34:45 host1 isakmpd: Phase II SA Negotiated
29. Dec 6 14:34:45 host1 isakmpd: PhaseII negotiation complete.
30. Dec 6 14:34:45 host1 Tunnel Manager: 0: TM is processing a P2\_sa\_created\_msg
31. Dec 6 14:34:45 host1 Tunnel Manager: 1: received p2\_sa\_created for an existing tunnel as initiator (tid)
32. Dec 6 14:34:45 host1 Tunnel Manager: 1: Filter::AddFilterRules: Created filter rules for tunnel
33. Dec 6 14:34:45 host1 Tunnel Manager: 0: TM is processing a List\_tunnels\_msg

The following paragraphs explain the log entries.

- 1-2** The **ike cmd=activate phase=1** command initiates a connection.
- 3-10** The **isakmpd** daemon negotiates a phase 1 tunnel.
- 11-12** The Tunnel Manager receives a valid phase 1 security association from the responder.
- 13** The Tunnel Manager checks whether **ike cmd=activate** has a phase 2 value for more work. It does not.
- 14-16** The **isakmpd** daemon finishes the phase 1 negotiation.
- 17-21** The **ike cmd=activate phase=2** command initiates a phase 2 tunnel.
- 22-29** The **isakmpd** daemon negotiates a phase 2 tunnel.
- 30-31** The Tunnel Manager receives a valid phase 2 security association from responder.
- 32** The Tunnel Manager writes the dynamic filter rules.
- 33** The **ike cmd=list** command views the IKE tunnels.

**Labels in field entries:**

The fields in the log entries are abbreviated to reduce DASD space requirements.

- #** The rule number that caused this packet to be logged.
- R** Rule Type
  - p** Permit
  - d** Deny
- i/o** Direction the packet was traveling when it was intercepted by the filter support code. Identifies IP address of the adapter associated with the packet:
  - For inbound (i) packets, this is the adapter that the packet arrived on.
  - For outbound (o) packets, this is the adapter that the IP layer has determined should handle the transmission of the packet.
- s** Specifies the IP address of the sender of the packet (extracted from the IP header).
- d** Specifies the IP address of the intended recipient of the packet (extracted from the IP header).
- p** Specifies the high-level protocol that was used to create the message in the data portion of the packet. May be a number or name, for example: udp, icmp, tcp, tcp/ack, ospf, pip, esp, ah, or all.
- sp/t** Specifies the protocol port number associated with the sender of the packet (extracted from the TCP/UDP header). When the protocol is ICMP or OSPF, this field is replaced with **t**, which specifies the IP type.
- dp/c** Specifies the protocol port number associated with the intended recipient of the packet (extracted from the TCP/UDP header). When the protocol is ICMP, this field is replaced with **c**, which specifies the IP code.
- Specifies that no information is available
- r** Indicates whether the packet had any local affiliation.
  - f** Forwarded packets
  - l** Local packets
  - o** Outgoing
  - b** Both
- l** Specifies the length of a particular packet in bytes.
- f** Identifies if the packet is a fragment.
- T** Indicates the tunnel ID.
- i** Specifies what interface the packet came in on.

**Internet Key-Exchange logging:**

You can enable logging of Internet Key-Exchange events to the SYSLOG facility with the **isakmpd** daemon.

For the **isakmpd** daemon, you enable logging using the **ike cmd=log** command. You can set the logging level in the **/etc/isakmpd.conf** configuration file with the **log\_level** parameter. Depending on the amount of information that you want to log, you can set the level to *none*, *errors*, *isakmp\_events*, or *information*.

For example, to specify that you want to log protocol information and implementation information, specify the following parameter:

```
log_level=INFORMATION
```

**Note:** For AIX 5.1 and earlier, the **isakmpd** daemon logs data to a separate file. This file is specified in **/etc/isakmpd.conf** file.

The **isakmpd** daemon starts one of two processes: it sends a proposal, or it evaluates a proposal. If the proposal is accepted, a security association is created and the tunnel is set up. If the proposal is not accepted or the connection ends before the negotiation completes, the **isakmpd** daemon indicates an error. The entries in the SYSLOG facility from **tmd** indicate whether the negotiation succeeded. A failure caused by a certificate that was not valid is logged to the SYSLOG facility. To determine the exact cause of a failed negotiation, review the data in the logging file that is specified in **/etc/syslog.conf**.

The SYSLOG facility adds a prefix to each line of the log, noting the date and time, the machine, and the program. The following example uses *googly* as the machine name and *isakmpd* as the program name:

```
Nov 20 09:53:50 googly isakmpd: ISAKMP_MSG_HEADER
Nov 20 09:53:50 googly isakmpd: Icookie : 0xef06a77488f25315, Rcookie :0x0000000000000000
Nov 20 09:53:51 googly isakmpd: Next Payload : 1(SA), Maj Ver : 1, Min Ver : 0
Nov 20 09:53:51 googly isakmpd: Xchg Type : 2 (ID protected), Flag= 0, Encr : No,COMMIT : No
Nov 20 09:53:51 googly isakmpd: Msg ID : 0x00000000
```

To improve clarity, use the **grep** command to extract log lines of interest (such as all **isakmpd** logging) and the **cut** command to remove the prefix from each line.

*The /etc/isakmpd.conf file:*

You can configure options for the **isakmpd** daemon in the **/etc/isakmpd.conf** file.

The following options are available in the **/etc/isakmpd.conf** file.

### Log configuration

Determine the amount of information that you want to log. Then set the level. The IKE daemons use this option to specify the level of logging.

**Syntax:** none | error | isakmp\_events | information

where the level has the following meaning:

**none** No logging. This is the default.

**error** Log protocol errors or application programming interface (API) errors.

#### **isakmp\_events**

Log IKE protocol events or errors. Use this level when debugging a problem.

#### **information**

Log protocol information and implementation information.

### Unrecognized IP address negotiation

You can set this option to YES or NO. When you set this option to YES, the local IKE database must contain an IP address for both phase-1 tunnel endpoints. You must specify YES for the host



to accept an incoming main-mode tunnel. The IP address can be the primary ID or an optional IP address that is associated with some other ID type.

Set this option to NO to accept an incoming main-mode connection. When you set the option to NO, the host might accept the connection even when the IKE database does not specify IP addresses for the phase 1 endpoints. However, in order for the host to accept the connection, you must use certificate-based authentication. This allows a host with a dynamically assigned IP address to initiate a main mode tunnel to the machine.

If you do not specify this parameter, the default is NO.

**Syntax:** MAIN\_MODE\_REQUIRES\_IP= YES | NO

### SOCKS4 server configuration

The SOCKS4\_PORTNUM option is optional. If you do not specify it, the default SOCKS-server port value of 1080 is used. The port value is used when the SOCKS server communicates with the HTTP server.

**Syntax:** *mnemonic = value*

where *mnemonic* and *value* can be the following values:

SOCKS4\_SERVER= specifies the server name

SOCKS4\_PORTNUM= specifies the SOCKS-server port number

SOCKS4\_USERID= user ID

### LDAP server configuration

**Syntax:** *mnemonic = value*

where *mnemonic* and *value* can be the following values:

LDAP\_SERVER= specifies the LDAP server name

LDAP\_VERSION= the version of the LDAP server (can be 2 or 3)

LDAP\_SERVERPORT= the LDAP-server port number

LDAP\_SEARCHTIME=client-search timeout value

### CRL Fetch Order

This option defines whether the HTTP or LDAP server is queried first, when both servers are configured. The CRL\_FETCH\_ORDER option is optional. The default fetch order is HTTP first, then LDAP, depending on whether both HTTP and LDAP servers are configured.

**Syntax:** CRL\_FETCH\_ORDER= *protocol#*, *protocol#*

where *protocol#* can be HTTP or LDAP.

### Internet Protocol security problem diagnosis

The following are some hints and tips that might assist you when you encounter a problem.

Set up logging when IPSec is first configured. Logs are very useful in determining what occurs with the filters and tunnels. (For detailed log information, see “Logging facilities” on page 252.)

#### ***Troubleshooting manual tunnel errors:***

The following are descriptions of several possible tunnel errors, along with their solutions.

Error: Issuing **mktun** command results in the following error:

```
insert_tun_man4(): write failed : The requested resource is busy.
```

Problem: The tunnel you requested to activate is already active or you have colliding SPI values.

To fix: Issue the **rmtun** command to deactivate, then issue the **mktun** command to activate. Check to see if the SPI values for the failing tunnel match any other active tunnel. Each tunnel should have its own unique SPI values.

Error: Issuing **mktun** command results in the following error:  
Device ipsec\_v4 is in Defined status.  
Tunnel activation for IP Version 4 not performed.

Problem: You have not made the IP Security device available.

To fix: Issue the following command:

```
mkdev -l ipsec -t 4
```

You might have to change **-t** option to 6 if you are getting the same error for IP Version 6 tunnel activation. The devices must be in available state. To check the IP Security device state, issue the following command:

```
lsdev -Cc ipsec
```

Error: Issuing a **gentun** command results in the following error:

Invalid Source IP address

Problem: You have not entered a valid IP address for the source address.

To fix: For IP Version 4 tunnels, check to see that you have entered an available IP Version 4 address for the local machine. You cannot use host names for the source when generating tunnels, you might only use host names for the destination.

For IP Version 6 tunnels, check to see that you entered an available IP Version 6 address. If you type `netstat -in` and no IP Version 6 addresses exist, run `/usr/sbin/autoconf6` (interface) for a link local autogenerated address (using MAC address) or use the **ifconfig** command to manually assign an address.

Error: Issuing a **gentun** command results in the following error:

Invalid Source IP address

Problem: You have not entered a valid IP address for the source address.

To fix: For IP Version 4 tunnels, check to see that you have entered an available IP Version 4 address for the local machine. You cannot use host names for the source when generating tunnels, you may only use host names for the destination.

For IP Version 6 tunnels, check to see that you entered an available IP Version 6 address. If you type `netstat -in` and no IP Version 6 addresses exist, run `/usr/sbin/autoconf6` (interface) for a link local auto-generated address (using MAC address) or use **ifconfig** to manually assign an address.

Error: Issuing **mktun** command results in the following error:

```
insert_tun_man4(): write failed : A system call received a parameter that is not valid.
```

Problem: Tunnel generation occurred with invalid ESP and AH combination or without the use of the new header format when necessary.

To fix: Check to see which authentication algorithms are in use by the particular tunnel in question. Remember that the HMAC\_MD5 and HMAC\_SHA algorithms require the new header format. The new header format can be changed using the SMIT fast path **ips4\_basic** or the **-z** parameter with the **chtun** command. Also, remember that DES\_CBC\_4 cannot be used with the new header format.

Error: Starting IP Security from Web-based System Manager results in a `Failure` message.

Problem: The IP Security daemons are not running.

To fix: View which daemons are running by entering the `ps -ef` command. The following daemons are associated with IP Security:

- **tmd**
- **isakmpd**
- **cpsd**

The **cpsd** daemon is active only if the digital certificate code is installed (the fileset named **gskit.rte** or **gskkm.rte**) and you have configured the Key Manager tool to contain digital certificates.

If the daemons are not active, stop IP Security using Web-based System Manager and then restart it, which automatically starts the appropriate daemons.

Error: Trying to use IP Security results in the following error:

The installed `bos.crypto` is back level and must be updated.

Problem: The **bos.net.ipsec.\*** files have been updated to a newer version, but the corresponding **bos.crypto.\*** files have not.

To fix: Update the **bos.crypto.\*** files to the version that corresponds with the updated **bos.net.ipsec.\*** files.

### ***Troubleshooting Internet Key Exchange tunnel errors:***

The following sections describe errors that can occur when using Internet Key Exchange (IKE) tunnels.

#### *Internet Key Exchange tunnel process flow:*

This section describes the process flow for the internet key exchange tunnel.

The IKE tunnels are set up by the communication of the **ike** command or the Web-based System Manager VPN panels with the following daemons:

*Table 13. Daemons used by IKE tunnels.*

|                |                          |
|----------------|--------------------------|
| <b>tmd</b>     | Tunnel Manager daemon    |
| <b>isakmpd</b> | IKE daemon               |
| <b>cpsd</b>    | Certificate proxy daemon |

For IKE tunnels to be correctly set up, the **tmd** and **isakmpd** daemons must be running. If IP Security is set to start at reboot, these daemons start automatically. Otherwise, they must be started using Web-based System Manager.

The Tunnel Manager gives requests to the **isakmpd** command to start a tunnel. If the tunnel already exists or is not valid (for instance, has an invalid remote address), it reports an error. If negotiation has started, it may take some time, depending on network latency, for the negotiation to complete. The **ike cmd=list** command can list the state of the tunnel to determine if the negotiation was successful. Also, the Tunnel Manager logs events to **syslog** to the levels of debug, event, and information, which can be used to monitor the progress of the negotiation.

The sequence is as follows:

1. Use Web-based System Manager or the **ike** command to initiate a tunnel.
2. The **tmd** daemon gives the **isakmpd** daemon a connection request for key management (phase 1).
3. The **isakmpd** daemon responds with SA created or an error message.

4. The **tmd** daemon gives the **isakmpd** daemon a connection request for a data management tunnel (phase 2).
5. The **isakmpd** daemon responds with SA created or an error message.
6. Tunnel parameters are inserted into the kernel tunnel cache.
7. Filter rules are added to the kernel dynamic filter table.

When the machine is acting as a responder, the **isakmpd** daemon notifies the Tunnel Manager **tmd** daemon that a tunnel has been negotiated successfully and a new tunnel is inserted into the kernel. In such cases, the process starts with step 3 and continues until step 7, without the **tmd** daemon issuing connection requests.

#### *Parse payload logging function:*

The security association (SA) between two end points is established by exchanging IKE messages. The Parse Payload function parses the messages in a human-readable format.

Parse payload logging can be enabled by editing the **/etc/isakmpd.conf** file. The logging entry in the **/etc/isakmpd.conf** file looks similar to the following:

```
information
```

The type of IKE payloads that Parse Payload logs depends on the content of the IKE message. Examples include SA Payload, Key Exchange Payload, Certificate Request Payload, Certificate Payload, and Signature Payload. The following is an example of a Parse Payload log in which an ISAKMP\_MSG\_HEADER is followed by five payloads:

```
ISAKMP_MSG_HEADER
 Icookie : 0x9e539a6fd4540990, Rcookie : 0x0000000000000000
 Next Payload : 1(SA), Maj Ver : 1, Min Ver : 0
 Xchg Type : 4 (Aggressive), Flag= 0, Encr : No, COMMIT : No
 Msg ID : 0x00000000
 len : 0x10e(270)
```

```
SA Payload:
 Next Payload : 4(Key Exchange), Payload len : 0x34(52)
 DOI : 0x1(INTERNET)
 bitmask : 1(SIT_IDENTITY_ONLY)
```

```
Proposal Payload:
 Next Payload : 0(NONE), Payload len : 0x28(40)
 Proposal # : 0x1(1), Protocol-ID : 1(ISAKMP)
 SPI size : 0x0(0), # of Trans : 0x1(1)
```

```
Transform Payload:
 Next Payload : 0(NONE), Payload len : 0x20(32)
 Trans # : 0x1(1), Trans.ID : 1(KEY_IKE)
 Attr : 1(Encr.Alg), len=0x2(2)
 Value=0x1(1), (DES-cbc)
 Attr : 2(Hash Alg), len=0x2(2)
 Value=0x1(1), (MD5)
 Attr : 3(Auth Method), len=0x2(2)
 Value=0x3(3), (RSA Signature)
 Attr : 4(Group Desc), len=0x2(2)
 Value=0x1(1), (default 768-bit MODP group)
 Attr : 11(Life Type), len=0x2(2)
 Value=0x1(1), (seconds)
 Attr : 12(Life Duration), len=0x2(2)
 Value=0x7080(28800)
```

```
Key Payload:
 Next Payload : 10(Nonce), Payload len : 0x64(100)
```

```
Key Data :
33 17 68 10 91 1f ea da 38 a0 22 2d 84 a3 5d 5d
a0 e1 1f 42 c2 10 aa 8d 9d 14 0f 58 3e c4 ec a3
9f 13 62 aa 27 d8 e5 52 8d 5c c3 cf d5 45 1a 79
8a 59 97 1f 3b 1c 08 3e 2a 55 9b 3c 50 cc 82 2c
```

```
d9 8b 39 d1 cb 39 c2 a4 05 8d 2d a1 98 74 7d 95
ab d3 5a 39 7d 67 5b a6 2e 37 d3 07 e6 98 1a 6b
```

Nonce Payload:

Next Payload : 5(ID), Payload len : 0xc(12)

Nonce Data:

6d 21 73 1d dc 60 49 93

ID Payload:

Next Payload : 7(Cert Req), Payload len : 0x49(73)

ID type : 9(DER\_DN), Protocol : 0, Port = 0x0(0)

Certificate Request Payload:

Next Payload : 0(NONE), Payload len : 0x5(5)

Certificate Encoding Type: 4(X.509 Certificate - Signature)

Within each payload, a **Next Payload** field points to the payload following the current payload. If the current payload is the last one in the IKE message, the **Next Payload** field has the value of zero (None).

Each Payload in the example has information pertaining to the negotiations that are going on. For example, the SA payload has the Proposal and Transform Payloads, which in turn show the encryption algorithm, authentication mode, hash algorithm, SA life type, and SA duration that the initiator is proposing to the responder.

Also, the SA Payload consists of one or more Proposal Payloads and one or more Transform Payloads. The **Next Payload** field for Proposal Payload has a value of either 0 if it is the only Proposal Payload or a value of 2 if it is followed by one more Proposal Payloads. Similarly, the **Next Payload** field for a Transform Payload has a value of 0 if it is the only Transform Payload, or a value of 3 if it is followed by one more Transform Payloads, as shown in the following example:

ISAKMP\_MSG\_HEADER

Icookie : 0xa764fab442b463c6, Rcookie : 0x0000000000000000

Next Payload : 1(SA), Maj Ver : 1, Min Ver : 0

Xchg Type : 2 (ID protected), Flag= 0, Encr : No, COMMIT : No

Msg ID : 0x00000000

len : 0x70(112)

SA Payload:

Next Payload : 0(NONE), Payload len : 0x54(84)

DOI : 0x1(INTERNET)

bitmask : 1(SIT\_IDENTITY\_ONLY)

Proposal Payload:

Next Payload : 0(NONE), Payload len : 0x48(72)

Proposal # : 0x1(1), Protocol-ID : 1(ISAKMP)

SPI size : 0x0(0), # of Trans : 0x2(2)

Transform Payload:

Next Payload : 3(Transform), Payload len : 0x20(32)

Trans # : 0x1(1), Trans.ID : 1(KEY\_IKE)

Attr : 1(Encr.Alg ), len=0x2(2)

Value=0x5(5), (3DES-cbc)

Attr : 2(Hash Alg ), len=0x2(2)

Value=0x1(1), (MD5)

Attr : 3(Auth Method ), len=0x2(2)

Value=0x1(1), (Pre-shared Key)

Attr : 4(Group Desc ), len=0x2(2)

Value=0x1(1), (default 768-bit MODP group)

Attr : 11(Life Type ), len=0x2(2)

Value=0x1(1), (seconds)

Attr : 12(Life Duration), len=0x2(2)

Value=0x7080(28800)

Transform Payload:

Next Payload : 0(NONE), Payload len : 0x20(32)

Trans # : 0x2(2), Trans.ID : 1(KEY\_IKE)

Attr : 1(Encr.Alg ), len=0x2(2)

Value=0x1(1), (DES-cbc)

Attr : 2(Hash Alg ), len=0x2(2)

Value=0x1(1), (MD5)

```

Attr : 3(Auth Method), len=0x2(2)
Value=0x1(1),(Pre-shared Key)
Attr : 4(Group Desc), len=0x2(2)
Value=0x1(1),(default 768-bit MODP group)
Attr : 11(Life Type), len=0x2(2)
Value=0x1(1),(seconds)
Attr : 12(Life Duration), len=0x2(2)
Value=0x7080(28800)

```

The IKE message header of a Parse Payload log shows the exchange type (Main Mode or Aggressive Mode), the length of the entire message, the message identifier, and so on.

The Certificate Request Payload requests a certificate from the responder. The responder sends the certificate in a separate message. The following example shows the Certificate Payload and Signature Payload that are sent to a peer as a part of an SA negotiation. The certificate data and the signature data are printed in hex format.

```

ISAKMP_MSG_HEADER
 Icookie : 0x9e539a6fd4540990, Rcookie : 0xc7e0a8d937a8f13e
 Next Payload : 6(Certificate), Maj Ver : 1, Min Ver : 0
 Xchg Type : 4 (Aggressive), Flag= 0, Encr : No,COMMIT : No
 Msg ID : 0x00000000
 len : 0x2cd(717)

```

Certificate Payload:

```

Next Payload : 9(Signature), Payload len : 0x22d(557)
Certificate Encoding Type: 4(X.509 Certificate - Signature)
Certificate: (len 0x227(551) in bytes
82 02 24 30 82 01 8d a0 03 02 01 02 02 05 05 8e
fb 3e ce 30 0d 06 09 2a 86 48 86 f7 0d 01 01 04
05 00 30 5c 31 0b 30 09 06 03 55 04 06 13 02 46
49 31 24 30 22 06 03 55 04 0a 13 1b 53 53 48 20
43 6f 6d 6d 75 6e 69 63 61 74 69 6f 6e 73 20 53
65 63 75 72 69 74 79 31 11 30 0f 06 03 55 04 0b
13 08 57 65 62 20 74 65 73 74 31 14 30 12 06 03
55 04 03 13 0b 54 65 73 74 20 52 53 41 20 43 41
30 1e 17 0d 39 39 30 39 32 31 30 30 30 30 30 30
5a 17 0d 39 39 31 30 32 31 32 33 35 39 35 39 5a
30 3f 31 0b 30 09 06 03 55 04 06 13 02 55 53 31
10 30 0e 06 03 55 04 0a 13 07 49 42 4d 2f 41 49
58 31 1e 30 1c 06 03 55 04 03 13 15 62 61 72 6e
65 79 2e 61 75 73 74 69 6e 2e 69 62 6d 2e 63 6f
6d 30 81 9f 30 0d 06 09 2a 86 48 86 f7 0d 01 01
01 05 00 03 81 8d 00 30 81 89 02 81 81 00 b2 ef
48 16 86 04 7e ed ba 4c 14 d7 83 cb 18 40 0a 3f
55 e9 ad 8f 0f be c5 b6 6d 19 ec de 9b f5 01 a6
b9 dd 64 52 34 ad 3d cd 0d 8e 82 6a 85 a3 a8 1c
37 e4 00 59 ce aa 62 24 b5 a2 ea 8d 82 a3 0c 6f
b4 07 ad 8a 02 3b 19 92 51 88 fb 2c 44 29 da 72
41 ef 35 72 79 d3 e9 67 02 b2 71 fa 1b 78 13 be
f3 05 6d 10 4a c7 d5 fc fe f4 c0 b8 b8 fb 23 70
a6 4e 16 5f d4 b1 9e 21 18 82 64 6d 17 3b 02 03
01 00 01 a3 0f 30 0d 30 0b 06 03 55 1d 0f 04 04
03 02 07 80 30 0d 06 09 2a 86 48 86 f7 0d 01 01
04 05 00 03 81 81 00 75 a4 ee 9c 3a 18 f2 de 5d
67 d4 1c e4 04 b4 e5 b8 5e 9f 56 e4 ea f0 76 4a
d0 e4 ee 20 42 3f 20 19 d4 25 57 25 70 0a ea 41
81 3b 0b 50 79 b5 fd 1e b6 0f bc 2f 3f 73 7d dd
90 d4 08 17 85 d6 da e7 c5 a4 d6 9a 2e 8a e8 51
7e 59 68 21 55 4c 96 4d 5a 70 7a 50 c1 68 b0 cf
5f 1f 85 d0 12 a4 c2 d3 97 bf a5 42 59 37 be fe
9e 75 23 84 19 14 28 ae c4 c0 63 22 89 47 b1 b6
f4 c7 5d 79 9d ca d0

```

Signature Payload:

```

Next Payload : 0(NONE), Payload len : 0x84(132)

```

```
Signature: len 0x80(128) in bytes
9d 1b 0d 90 be aa dc 43 95 ba 65 09 b9 00 6d 67
b4 ca a2 85 0f 15 9e 3e 8d 5f e1 f0 43 98 69 d8
5c b6 9c e2 a5 64 f4 ef 0b 31 c3 cb 48 7c d8 30
e3 a2 87 f4 7c 9d 20 49 b2 39 00 fa 8e bf d9 b0
7d b4 8c 4e 19 3a b8 70 90 88 2c cf 89 69 5d 07
f0 5a 81 58 2e 15 40 37 b7 c8 d6 8c 5c e2 50 c3
4d 19 7e e0 e7 c7 c2 93 42 89 46 6b 5f f8 8b 7d
5b cb 07 ea 36 e5 82 9d 70 79 9a fe bd 6c 86 36
```

*Digital certificate and signature mode problems:*

The following are possible digital certificate and signature mode problems you can encounter, and corresponding solutions.

**Error:** The **cpsd** (Certificate Proxy Server daemon) does not start. An entry similar to the following appears in the log file:

```
Sep 21 16:02:00 ripple CPS[19950]: Init():LoadCaCerts() failed, rc=-12
```

**Problem:** The certificate database has not opened or has not been found.

**To Fix:** Ensure that the Key Manager certificate databases are present in **/etc/security**. The following files make up the database: **ikekey.crl**, **ikekey.kdb**, **ikekey.rdb**, **ikekey.sth**.

If only the **ikekey.sth** file is missing, the stash password option was not selected when the Key Manager database was created. The password must be stashed to enable using digital certificates with IP Security. (See Creating a Key Database for more information.)

**Error:** Key Manager gives the following error when receiving a certificate:

```
Invalid Base64-encoded data was found
```

**Problem:** Superfluous data has been found in the certificate file or else data was lost or corrupted.

**To Fix:** The 'DER' Encoded Certificate should be contained within the following strings (shown below). No other characters should precede or follow other than the BEGIN and END CERTIFICATE strings.

```
-----BEGIN CERTIFICATE-----
MIICMTCAZqgAwIBAgIFFKZtANowDQYJKoZIhvcNAQEFBQAwXDELMAkGA1UEBhMC
RkxkZDAiBgNVBAoTGINTSCBDb21tdW5pY2F0aW9ucyBTZW51cm10eTERMA8GA1UE
CxMIY2ViIHRlc3QxZDASBgNVBAMTC1Rlc3QgU1NBIE5BMB4XDTK5MDkyMTAwMDAw
MFoXDTk5MTAyMTIzNTk1OVowOzELMAkGA1UEBhMCMVVMxDDAKBgNVBAoTA01CTTEe
MBwGA1UEAxMVcm1wcGx1LmF1c3Rpbj5pYm0uY29tMIGfMA0GCSqGSIb3DQEBAQUA
A4GNADCBiQKBgQC5EZqo6n7tZrpAL6X4L7mf4yXQSm+m/NsJLhp6afbFpPvXgYWC
wq4pv0tvxgum+FHrE0gysNjbKkE4Y6ixC9PGGAKHnhM3vrmvFjn11G6KtyEz58Lz
BWW39QS6Nj1LqqP1nT+y3+Xzvfv8Eonqzno8mg1CWXM09SguLmWoU1PcZQIDAQAB
oyAwHjALBgNVHQ8EBAMCBaAwDwYDVR0RBAGwBocECQNhhzANBgkqhkiG9w0BAQUF
A0BgQA6bgp4Zay34/fyA1yCkNNAYJRrN3Vc4NHN7IGjUziN6jK5UyB5zL37FERW
hT9ArPLzK7yEZs+MDNvB0bosyGWEDYPZr7EZHHYcoBP4/cd0V5rBFmA8Y2gUthPi
Ioxpi4+KZGHYlqTrm+8Is/DVJaQmCGRPynHK35xjT6WuQt iYg==
-----END CERTIFICATE-----
```

The following options can help you diagnose and solve this problem.

- If data was lost or corrupted, recreate the Certificate
- Use an ASN.1 parser (available on the Internet World Wide Web) to check whether the certificate is valid by parsing the certificate successfully.

**Error:** Key Manager gives the following error when receiving a personal certificate:

```
No request key was found for the certificate
```

**Problem:** A Personal Certificate Request does not exist for the personal certificate being received.

**To Fix:** Create the Personal Certificate Request again and request a new certificate.

Error: Web-based System Manager gives the following error when you configure an IKE tunnel:

```
Error 171 in the Key Management (Phase 1) Tunnel operation:
PUT_IRL_FAILED
```

Problem: One cause for this error is that the host identity type, which is configured on the IKE dialog (Identification tab), is invalid. This can happen when the host identity type selected from the pull-down list does not logically match the type entered in the Host Identity field. For example, if you select a host identity type of X500 Distinguished Name, you must enter a properly formatted distinguished name in the **Host Identity** field.

To Fix: Ensure the distinguished name you enter is correct for the type selected in the host identity pull-down list.

Error: An IKE negotiation fails and an entry similar to the following appears in the log file:

```
inet_cert_service::channelOpen():clientInitIPC():error,rc =2
(No such file or directory)
```

Problem: The **cpsd** is not running or has stopped.

To Fix: Start IP Security using Web-based System Manager. This action also starts the appropriate daemons.

Error: An IKE negotiation fails and an entry similar to the following appears in the log file:

```
CertRepo::GetCertObj: DN Does Not Match: ("/C=US/O=IBM/CN=ripple.austin.ibm.com")
```

Problem: The X.500 Distinguished Name (DN) entered while defining the IKE tunnel does not match the X.500 DN in the personal certificate.

To Fix: Change the IKE tunnel definition in Web-based System Manager to match the distinguished name in the certificate.

Error: While defining IKE tunnels in Web-based System Manager, the Digital certificate check box is disabled under the **Authentication Method** tab.

Problem: The policy associated with this tunnel does not use RSA signature mode authentication.

To Fix: Change the transform of the associated policy to use the RSA signature authentication method. For example, you can choose **IBM\_low\_CertSig** as a key management policy when defining a IKE tunnel.

### **Tracing facilities:**

Tracing is a debugging facility for tracing kernel events. Traces can be used to get more specific information about events or errors occurring in the kernel filter and tunnel code.

The SMIT IP Security trace facility is available through the Advanced IP Security Configuration menu. The information captured by this trace facility includes information on Error, Filter, Filter Information, Tunnel, Tunnel Information, Capsulation/Decapsulation, Capsulation Information, Crypto, and Crypto Information. By design, the error trace hook provides the most critical information. The info trace hook can generate critical information and may have an impact on system performance. This tracing provides clues as to what a problem might be. Tracing information is also required when speaking with a service technician. To access the tracing facility, use the SMIT fast path **smit ips4\_tracing** (for IP Version 4) or **smit ips6\_tracing** (for IP Version 6).

### **ipsestat command:**

You can use the **ipsestat** command to list the status of IP Security devices, IP Security crypto algorithms, and statistics of IP Security packets.

Issuing the **ipsestat** command will generate the following sample report, which shows that the IP Security devices are in the available state, that there are three authentication algorithms installed, three encryption



algorithms installed, and that there is a current report of packet activity. This information could be useful to you in determining where a problem exists if you are troubleshooting your IP Security traffic.

IP Security Devices:

ipsec\_v4 Available

ipsec\_v6 Available

Authentication Algorithm:

HMAC\_MD5 -- Hashed MAC MD5 Authentication Module

HMAC\_SHA -- Hashed MAC SHA Hash Authentication Module

KEYED\_MD5 -- Keyed MD5 Hash Authentication Module

Encryption Algorithm:

CDMF -- CDMF Encryption Module

DES\_CBC\_4 -- DES CBC 4 Encryption Module

DES\_CBC\_8 -- DES CBC 8 Encryption Module

3DES\_CBC -- Triple DES CBC Encryption Module

IP Security Statistics -

Total incoming packets: 1106

Incoming AH packets:326

Incoming ESP packets: 326

Srcrte packets allowed: 0

Total outgoing packets:844

Outgoing AH packets:527

Outgoing ESP packets: 527

Total incoming packets dropped: 12

Filter denies on input: 12

AH did not compute: 0

ESP did not compute:0

AH replay violation:0

ESP replay violation: 0

Total outgoing packets dropped:0

Filter denies on input:0

Tunnel cache entries added: 7

Tunnel cache entries expired: 0

Tunnel cache entries deleted: 6

**Note:** Beginning with AIX 4.3.2, there is no need to use CDMF because DES is now available worldwide. Reconfigure any tunnels that use CDMF to use DES or Triple DES.

## IP security reference

There are commands and methods for IP security. You can also migrate IKE tunnels, filters, and pre-shared keys.

### **List of commands:**

The following table provides a list of commands.

|                         |                                                                          |
|-------------------------|--------------------------------------------------------------------------|
| <b>ike cmd=activate</b> | Starts an Internet Key Exchange (IKE) negotiation (AIX 4.3.3 and later). |
| <b>ike cmd=remove</b>   | Deactivates IKE tunnels (AIX 4.3.3 and later)                            |
| <b>ike cmd=list</b>     | Lists IKE tunnels (AIX 4.3.3 and later)                                  |
| <b>ikedb</b>            | Provides the interface to the IKE tunnel database(AIX 5.1 and later)     |
| <b>gentun</b>           | Creates a tunnel definition                                              |
| <b>mktun</b>            | Activates tunnel definition(s)                                           |
| <b>chtun</b>            | Changes a tunnel definition                                              |
| <b>rmtun</b>            | Removes a tunnel definition                                              |
| <b>lstun</b>            | Lists tunnel definition(s)                                               |
| <b>exptun</b>           | Exports tunnel definition(s)                                             |
| <b>imptun</b>           | Imports tunnel definition(s)                                             |
| <b>genfilt</b>          | Creates a filter definition                                              |
| <b>mkfilt</b>           | Activates filter definition(s)                                           |

|                      |                                                  |
|----------------------|--------------------------------------------------|
| <b>mvfilt</b>        | Moves a filter rule                              |
| <b>chfilt</b>        | Changes a filter definition                      |
| <b>rmfilt</b>        | Removes a filter definition                      |
| <b>lsfilt</b>        | Lists filter definition(s)                       |
| <b>expfilt</b>       | Exports filter definition(s)                     |
| <b>impfilt</b>       | Imports filter definition(s)                     |
| <b>ipsec_convert</b> | Lists status of IP security                      |
| <b>ipsecstat</b>     | Lists status of IP security                      |
| <b>ipsectrbuf</b>    | Lists the contents of IP security tracing buffer |
| <b>unloadipsec</b>   | Unloads a crypto module                          |

### **List of methods:**

The following table provides a list of methods.

|                  |                                                                     |
|------------------|---------------------------------------------------------------------|
| <b>defipsec</b>  | Defines an instance of IP Security for IP Version 4 or IP Version 6 |
| <b>cfgipsec</b>  | Configures and loads <b>ipsec_v4</b> or <b>ipsec_v6</b>             |
| <b>ucfgipsec</b> | Unconfigures <b>ipsec_v4</b> or <b>ipsec_v6</b>                     |

### **IP security migration:**

You can migrate your IKE tunnels, filters and pre-shared keys from AIX 4.3 to AIX 5.2.

#### *Migrating IKE tunnels:*

To migrate your tunnels, complete the following steps on a system running AIX 4.3:

1. Run the **bos.net.ipsec.keymgt.pre\_rm.sh** script. When you run this script, the following files are created in the **/tmp** directory:
  - a. **p2proposal.bos.net.ipsec.keymgt**
  - b. **p1proposal.bos.net.ipsec.keymgt**
  - c. **p1policy.bos.net.ipsec.keymgt**
  - d. **p2policy.bos.net.ipsec.keymgt**
  - e. **p1tunnel.bos.net.ipsec.keymgt**
  - f. **p2tunnel.bos.net.ipsec.keymgt**

**Attention:** Run this script only once. If you update the database and run the script again, you will lose all of the files, and you can not retrieve them. Read the script in “The bos.net.ipsec.keymgt.pre\_rm.sh script” on page 267 before you migrate your tunnels.

2. Save the files created by the script and the **/tmp/lpplevel** file to some external media, such as a CD or floppy disk.

#### *Migrating pre-shared keys:*

Perform the following steps to update the pre-shared key format.

The IKE tunnel pre-shared key database is also corrupted during migration. To update the pre-shared key format, complete the following steps on the system that has been migrated to AIX 5.2:

1. Save the output of the **ikedb -g** command by running the following command:

```
ikedb -g > out.keys
```
2. Edit the **out.keys** file to replace **FORMAT=ASCII** with **FORMAT=HEX** for the pre-shared key format.
3. Input the XML file by running the following command:

```
ikedb -pF out.keys
```

### *Migrating filters:*

Perform the following steps to migrate filters.

1. Export the filter rules files to the **/tmp** directory using SMIT by completing the following steps:
  - a. Run the **smitty ipsec4** command.
  - b. Select **Advanced IP Security Configuration—>Configure IP Security Filter Rules—>Export IP Security filter rules**.
  - c. Enter **/tmp** for the directory name.
  - d. Under the Filter Rules option press F4 and select **all** from the list.
  - e. Press enter to save the filter rules in the **/tmp/ipsec\_fltr\_rule.exp** file on the external media.Complete this process for all of the systems you are migrating from AIX 4.3 to AIX 5.2.
2. Copy the six tunnel files created by the script, the **/tmp/lpplevel** file, and the **/tmp/ipsec\_fltr\_rule.exp** file to the **/tmp** directory on the migrated system.
3. Run the **bos.net.ipsec.keymgt.post\_i.sh** script to repopulate the tunnel configurations into the database.
4. Run the **ikedb -g** command to verify that the tunnels are in the database.

**Note:** If you do not see the tunnel information in the database, run the script again, but rename all the **\*.loaded** files in **/tmp** directory to their original names.

On a system that has been migrated to AIX 5.2, the filter database is corrupted after migration. If you run the **lsfilt** command on the migrated system, you will get the following error:

```
Cannot get ipv4 default filter rule
```

To update the filter database, complete the following steps:

1. Replace the **ipsec\_filter** file and the **ipsec\_filter.vc** file in the **/etc/security** directory with the uncorrupted files from a newly migrated system running AIX 5.2. If you do not have these files, you can request them from IBM Service.
2. Import the filter rules files to the **/tmp** directory using SMIT by completing the following steps:
  - a. Run the **smitty ipsec4** command.
  - b. Select **Advanced IP Security Configuration—>Configure IP Security Filter Rules—>Import IP Security filter rules**.
  - c. Enter **/tmp** for the directory name.
  - d. Under the **Filter Rules** option press **F4** and select **all** from the list.
  - e. Press Enter to recreate the filter rules. You can list the filter rules through SMIT or with the **lsfilt** command.

*The bos.net.ipsec.keymgt.pre\_rm.sh script:*

The **bos.net.ipsec.keymgt.pre\_rm.sh** script saves the contents of the tunnel database on a system running AIX 4.3.

```
#!/usr/bin/ksh
keymgt_installed=`ls|pp -Lqc bos.net.ipsec.keymgt 2>/dev/null | awk -F: '{print $6}' | head -1`

if [! "$keymgt_installed"]
then
 exit 0
fi

Copy the database to a save directory in case changes fail
if [-d /etc/ipsec/inet/DB]
then
```

```

cp -R /etc/ipsec/inet/DB /etc/ipsec/inet/DB.sav || exit $?
fi

Remember the level you are migrating from
VRM=$(LANG=C lslpp -Lqc bos.net.ipsec.keymgt 2>/dev/null | awk -F: '{print $3}' | \
awk -F. '{print $1"."$2"."$3}')
VR=${VRM%.*}
echo $VRM > /tmp/lpplevel

IKEDB=$(which ikedb) || IKEDB=/usr/sbin/ikedb

XMLFILE=/tmp/full_ike_database.bos.net.ipsec.keymgt
PSKXMLFILE=/tmp/psk_ike_database.bos.net.ipsec.keymgt

See if ikedb exists.
if [-f $IKEDB]
then

If either of the ikedb calls below fails, that's OK. Just remove the
resulting file (which may contain garbage) and continue. The post_i
script will simply not import the file if it doesn't exist, which will
mean part or all of the IKE database is lost, but this is preferable
to exiting the script with an error code, which causes the entire
migration to fail.

$IKEDB -g > $XMLFILE
if [$? -ne 0]
then
rm -f $XMLFILE || exit $?
fi

if [[$VR = "5.1"]]; then
This is a special case. The 5.1 version of ikedb is the only
one that does not include preshared keys in the full database
output. So we have to retrieve those separately.
$IKEDB -g -t IKEPresharedKey > $PSKXMLFILE
if [$? -ne 0]
then
rm -f $PSKXMLFILE || exit $?
fi
fi

Make sure ikegui command is installed
elif [-f /usr/sbin/ikegui]
then

Get database information and save to /tmp
/usr/sbin/ikegui 0 1 0 0 > /tmp/p1proposal.bos.net.ipsec.keymgt 2>/dev/null
RC=$?
if [[$RC -ne 0]]
then
rm -f /tmp/p1proposal.bos.net.ipsec.keymgt || exit $?
fi

/usr/sbin/ikegui 0 1 1 0 > /tmp/p1policy.bos.net.ipsec.keymgt 2>/dev/null
RC=$?
if [[$RC -ne 0]]
then
rm -f /tmp/p1policy.bos.net.ipsec.keymgt || exit $?
fi

/usr/sbin/ikegui 0 2 0 0 > /tmp/p2proposal.bos.net.ipsec.keymgt 2>/dev/null
RC=$?
if [[$RC -ne 0]]
then
rm -f /tmp/p2proposal.bos.net.ipsec.keymgt || exit $?
fi

```

```

/usr/sbin/ikegui 0 2 1 0 > /tmp/p2policy.bos.net.ipsec.keymgt 2>/dev/null
RC=$?
if [[$RC -ne 0]]
then
 rm -f /tmp/p2policy.bos.net.ipsec.keymgt || exit $?
fi

/usr/sbin/ikegui 0 1 2 0 > /tmp/p1tunnel.bos.net.ipsec.keymgt 2>/dev/null
RC=$?
if [[$RC -ne 0]]
then
 rm -f /tmp/p1tunnel.bos.net.ipsec.keymgt || exit $?
fi

/usr/sbin/ikegui 0 2 2 0 > /tmp/p2tunnel.bos.net.ipsec.keymgt 2>/dev/null
RC=$?
if [[$RC -ne 0]]
then
 rm -f /tmp/p2tunnel.bos.net.ipsec.keymgt || exit $?
fi

fi

```

*The bos.net.ipsec.keymgt.post\_i.sh script:*

The **bos.net.ipsec.keymgt.post\_i.sh** script loads the contents of the tunnel database on to a migrated system running AIX 5.2.

```

#!/usr/bin/ksh

function PrintDot {
 echo "echo \c"
 echo "\".\c"
 echo "\\c\c"
 echo "\"\c"
 echo
}

function P1PropRestore {
 while :
 do
 read NAME
 read MODE
 if [[$? = 0]]; then
 echo "ikegui 1 1 0 $NAME $MODE \c"
 MORE=1
 while [[$MORE = 1]];
 do
 read AUTH
 read HASH
 read ENCRYPT
 read GROUP
 read TIME
 read SIZE
 read MORE
 echo "$AUTH $HASH $ENCRYPT $GROUP $TIME $SIZE $MORE \c"
 done
 echo " > /dev/null 2>&1"
 PrintDot
 else
 return 0
 fi
 done
}

function P2PropRestore {

```

```

while :
do
 read NAME
 FIRST=yes
 MORE=1
 while [[$MORE = 1]];
 do
 read PROT
 if [[$? = 0]]; then
 read AH_AUTH
 read ESP_ENCR
 read ESP_AUTH
 read ENCAP
 read TIME
 read SIZE
 read MORE
 if [[$FIRST = "yes"]]; then
 echo "ikegui 1 2 0 $NAME $MODE \c"
 fi
 echo "$PROT $AH_AUTH $ESP_ENCR $ESP_AUTH $ENCAP $TIME $SIZE $MORE \c"
 FIRST=no
 else
 return 0
 fi
 done
 echo " > /dev/null 2>&1"
 PrintDot
done
}

function P1PolRestore {
 while :
 do
 read NAME
 read ROLE
 if [[$? = 0]]; then
 read TIME
 read SIZE
 read OVERLAP
 read TTIME
 read TSIZE
 read MIN
 read MAX
 read PROPOSAL
 echo "ikegui 1 1 1 $NAME $ROLE $OVERLAP $TTIME $TSIZE $MIN $MAX 1 0 0 $PROPOSAL > \
/dev/null 2>&1"
 PrintDot
 else
 return 0
 fi
 done
}

function P2PolRestore {
 while :
 do
 read NAME
 read ROLE
 if [[$? = 0]]; then
 read IPFS
 read RPFS
 read TIME
 read SIZE
 read OVERLAP
 read TTIME
 read TSIZE
 read MIN

```

```

 read MAX
 echo "ikegui 1 2 1 $NAME $ROLE $IPFS $RPFS $OVERLAP $TTIME $TSIZE $MIN $MAX 1 0 0 \c"
 MORE=1
 while [[$MORE = 1]];
 do
 read PROPOSAL
 read MORE
 echo "$PROPOSAL $MORE \c"
 FIRST=no
 done
 else
 return 0
 fi
 echo " > /dev/null 2>&1"
 PrintDot
done
}

function P1TunRestore {
 while :
 do
 read TUNID
 read NAME
 if [[$? = 0]]; then
 read LID_TYPE
 read LID
 if [[$LPPLEVEL = "4.3.3"]]; then
 read LIP
 fi
 read RID_TYPE
 read RID
 read RIP
 read POLICY
 read KEY
 read AUTOSTART
 echo "ikegui 1 1 2 0 $NAME $LID_TYPE \"$LID\" $LIP $RID_TYPE \"$RID\" \
$RIP $POLICY $KEY $AUTOSTART > /dev/null 2>&1"
 PrintDot
 else
 return 0
 fi
 done
}

function P2TunRestore {
 while :
 do
 read TUNID
 read NAME
 if [[$? = 0]]; then
 read PITUN
 read LTYPE
 read LID
 read LMASK
 read LPROT
 read LPORT
 read RTYPE
 read RID
 read RMASK
 read RPROT
 read RPORT
 read POLICY
 read AUTOSTART
 echo "ikegui 1 2 2 0 $NAME $PITUN $LTYPE $LID $LMASK $LPROT $LPORT $RTYPE
 \ $RID $RMASK $RPROT $RPORT $POLICY $AUTOSTART > /dev/null 2>&1"
 PrintDot
 else

```

```

 return 0
 fi
done
}

function allRestoreWithIkedb {

 ERRORS=/tmp/ikedb_msgs.bos.net.ipsec.keymgt
 echo > $ERRORS
 $IKEDB -p $XMLFILE 2>> $ERRORS
 if [-f $PSKXMLFILE]
 then
 $IKEDB -p $PSKXMLFILE 2>> $ERRORS
 fi

}

P1PROPFIE=/tmp/p1proposal.bos.net.ipsec.keymgt
P2PROPFIE=/tmp/p2proposal.bos.net.ipsec.keymgt
P1POLFILE=/tmp/p1policy.bos.net.ipsec.keymgt
P2POLFILE=/tmp/p2policy.bos.net.ipsec.keymgt
P1TUNFILE=/tmp/p1tunnel.bos.net.ipsec.keymgt
P2TUNFILE=/tmp/p2tunnel.bos.net.ipsec.keymgt
XMLFILE=/tmp/full_ike_database.bos.net.ipsec.keymgt
PSKXMLFILE=/tmp/psk_ike_database.bos.net.ipsec.keymgt
CMD_FILE=/tmp/commands
IKEDB=$(which ikedb) || IKEDB=/usr/sbin/ikedb

echo "building ISAKMP database \n"
$IKEDB -x || exit $?

if [-f $XMLFILE]; then
 echo "\nRestoring database entries\c"
 allRestoreWithIkedb
 echo "\ndone\n"

elif [-f /tmp/*.bos.net.ipsec.keymgt]; then
 echo "\nRestoring database entries\c"

 LPPLEVEL=`cat /tmp/lpplevel`

 echo > $CMD_FILE
 touch $P1PROPFIE; P1PropRestore < $P1PROPFIE >> $CMD_FILE
 touch $P2PROPFIE; P2PropRestore < $P2PROPFIE >> $CMD_FILE
 touch $P1POLFILE; P1PolRestore < $P1POLFILE >> $CMD_FILE
 touch $P2POLFILE; P2PolRestore < $P2POLFILE >> $CMD_FILE
 touch $P1TUNFILE; P1TunRestore < $P1TUNFILE >> $CMD_FILE
 touch $P2TUNFILE; P2TunRestore < $P2TUNFILE >> $CMD_FILE

 mv $P1PROPFIE ${P1PROPFIE}.loaded
 mv $P2PROPFIE ${P2PROPFIE}.loaded
 mv $P1POLFILE ${P1POLFILE}.loaded
 mv $P2POLFILE ${P2POLFILE}.loaded
 mv $P1TUNFILE ${P1TUNFILE}.loaded
 mv $P2TUNFILE ${P2TUNFILE}.loaded

 ksh $CMD_FILE

 echo "done\n"
fi

```

## Network Information Services and NIS+ security

NIS+ security is an integral part of the NIS+ namespace. You cannot set up security independently from the namespace. For this reason, instructions for setting up security are woven through the steps used to set up the other components of the namespace.



## Operating system security mechanisms

Operating system security is provided by gates that users must pass through before entering the operating system environment, and permission matrixes that determine what they are able to do once inside. In some contexts, *secure RPC* passwords have been referred to as *network passwords*.

The overall system is composed of four gates and two permission matrixes:

### Dialup gate

To access a given operating system environment from the outside through a modem and phone line, you must provide a valid login ID and dial-up password.

### Login gate

To enter a given operating system environment you must provide a valid login ID and user password.

### Root gate

To gain access to root privileges, you must provide a valid root user password.

### Secure RPC gate

In an NIS+ environment running at security level 2 (the default), when you try to use NIS+ services and gain access to NIS+ objects (servers, directories, tables, table entries, and so on) your identity is confirmed by NIS+, using the secure RPC process.

Entering the secure RPC gate requires presentation of a secure RPC password. Your secure RPC password and your login password normally are identical. When that is the case, you are passed through the gate automatically without having to re-enter your password. (In some contexts, *secure RPC* passwords have been referred to as *network passwords*. See the Administering NIS+ Credentials section in the *AIX Version 6.1 Network Information Services (NIS and NIS+) Guide* for information about handling two passwords that are not identical.)

A set of *credentials* is used to automatically pass your requests through the secure RPC gate. The process of generating, presenting, and validating your credentials is called *authentication* because it confirms who you are and that you have a valid secure RPC password. This authentication process is automatically performed every time you request NIS+ service.

In an NIS+ environment running in NIS-compatibility mode, the protection provided by the secure RPC gate is significantly weakened because everyone has read rights for all NIS+ objects and modify rights for those entries that apply to them regardless of whether or not they have a valid credential (that is, regardless of whether or not the authentication process has confirmed their identity and validated their secure RPC password). Because this situation allows *anyone* to have read rights for all NIS+ objects and modify rights for those entries that apply to them, an NIS+ network running in compatibility mode is less secure than one running in normal mode. (In secure RPC terminology, any user without a valid credential is considered a member of the nobody class. See “Authorization classes” on page 278 for a description of the four classes.)

For details on how to administer NIS+ authentication and credentials, see the Administering NIS+ Credentials section in the *AIX Version 6.1 Network Information Services (NIS and NIS+) Guide*.

### File and directory matrix

Once you have gained access to an operating system environment, your ability to read, execute, modify, create, and destroy files and directories is governed by the applicable permissions.

### NIS+ objects matrix

Once you have been properly authenticated to NIS+, your ability to read, modify, create, and destroy NIS+ objects is governed by the applicable permissions. This process is called *NIS+ authorization*.

For details on NIS+ permissions and authorization, see the Administering NIS+ Access Rights section in the *AIX Version 6.1 Network Information Services (NIS and NIS+) Guide*.

## NIS+ Security mechanisms

Once an NIS+ security environment has been set up, you can add and remove users, change permissions, reassign group members, and perform all other routine administrative tasks needed to manage an evolving network.

The security features of NIS+ protect the information in the namespace, as well as the structure of the namespace itself, from unauthorized access. Without these security features, any NIS+ client could obtain, change, or even damage information stored in the namespace.

NIS+ security serves two purposes:

### Authentication

Authentication is used to identify NIS+ principals. Every time a principal (either user or machine) tries to access an NIS+ object, the user's identity and secure RPC password is confirmed and validated. (You should not have to enter a password as part of the authentication process. However, if for some reason your secure RPC password is different from your login password, you must perform a **keylogin** the first time you try accessing NIS+ objects or services. To perform a **keylogin**, you must provide a valid secure RPC password. See the Administering NIS+ Credentials section in the *AIX Version 6.1 Network Information Services (NIS and NIS+) Guide*.)

### Authorization

Authorization is used to specify access rights. Every time NIS+ principals try to access NIS+ objects, they are placed in one of four authorization classes (owner, group, world, nobody). The NIS+ security system allows NIS+ administrators to specify different read, modify, create, or destroy rights to NIS+ objects for each class. For example, a given class could be permitted to modify a particular column in the passwd table but not read that column, or a different class could be allowed to read some entries of a particular table but not others.

For example, a given NIS+ table might allow one class to both read and modify the information in the table, but a different class is only allowed to read the information, and a third class is not even allowed to do that. This is similar in concept to the operating system's file and directory permissions system. (See "Authorization classes" on page 278 for more information on classes.)

Authentication and authorization prevents someone with root privileges on machine A from using the **su** command to assume the identity of a second user who is either not logged in at all or logged in on machine B, and then accessing NIS+ objects with the second user's NIS+ access privileges.

Note, however, that NIS+ cannot prevent someone who knows another user's login password from assuming that other user's identity and NIS+ access privileges. Nor can NIS+ prevent a user with root privileges from assuming the identity of another user who is logged in from the *same* machine.

The following figure details the NIS+ security process.

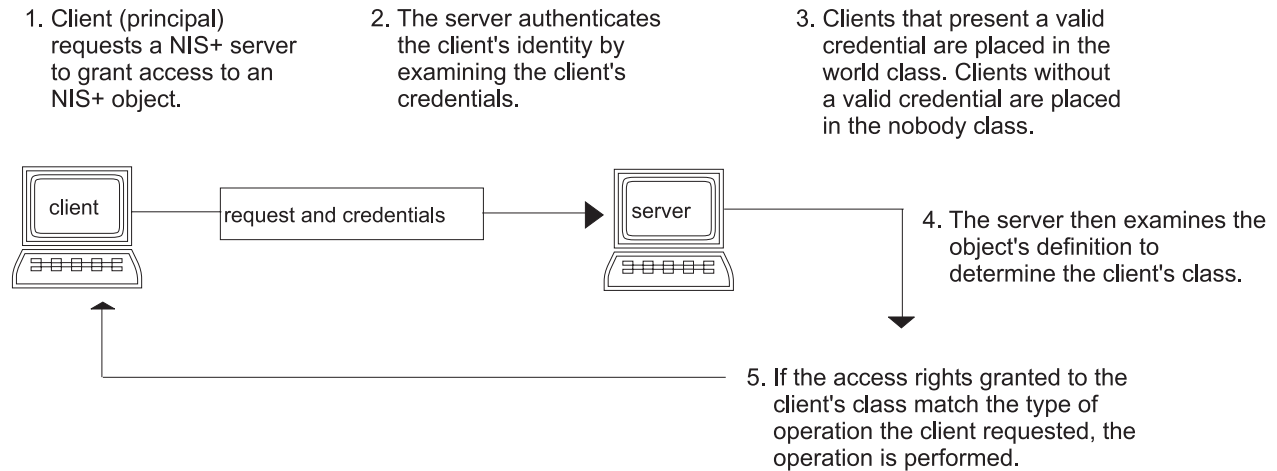

Figure 15. Summary of NIS+ Security Process

1. The client or principal requests an NIS+ server to grant access to an NIS+ object.
2. The server authenticates the client's identity by examining the client's credentials.
3. The clients with valid credentials are placed in the world class.
4. The clients without valid credentials are placed in the nobody class.
5. The server examines the object's definition to determine the client's class.
6. If the access rights granted to the client's class match the type of operation requested, the operation is performed.

### NIS+ Principals:

NIS+ principals are the entities (clients) that submit requests for NIS+ services.

An NIS+ principal might be someone who is logged in to a client machine as a regular user, someone who is logged in as root user, or any process that runs with root user permission on an NIS+ client machine. Thus, an NIS+ principal can be a client user or a client workstation.

An NIS+ principal can also be the entity that supplies an NIS+ service from an NIS+ server. Because all NIS+ servers are also NIS+ clients, much of the information in this section also applies to servers.

### NIS+ Security levels:

NIS+ servers operate at one of two security levels. These levels determine the types of credential principals must submit for their requests to be authenticated.

NIS+ is designed to run at the most secure level, which is security level 2. Level 0 is provided only for testing, setup, and debugging purposes. These security levels are summarized in the following table.

**Note:** Use Web-based System Manager, SMIT, or the **passwd** command to change your own password regardless of security level or credential status.

NIS+ security levels

| Severity level | Description                                                                                                                                                                                                                                                                                                                                                                                       |
|----------------|---------------------------------------------------------------------------------------------------------------------------------------------------------------------------------------------------------------------------------------------------------------------------------------------------------------------------------------------------------------------------------------------------|
| 0              | Security level 0 is designed for testing and setting up the initial NIS+ namespace. An NIS+ server running at security level 0 grants any NIS+ principal full access rights to all NIS+ objects in the domain. Level 0 is for setup purposes only and should only be used by administrators for that purpose. Level 0 should <i>not</i> be used on networks in normal operation by regular users. |

## NIS+ security levels

| Severity level | Description                                                                                                                                                                                                                                                                                                                                                                                                                                                                                                                                                                                                                                                                                                                       |
|----------------|-----------------------------------------------------------------------------------------------------------------------------------------------------------------------------------------------------------------------------------------------------------------------------------------------------------------------------------------------------------------------------------------------------------------------------------------------------------------------------------------------------------------------------------------------------------------------------------------------------------------------------------------------------------------------------------------------------------------------------------|
| 1              | Security level 1 uses AUTH_SYS security. This level is not supported by NIS+ and should <i>not</i> be used.                                                                                                                                                                                                                                                                                                                                                                                                                                                                                                                                                                                                                       |
| 2              | Security level 2 is the default. The highest level of security currently provided by NIS+, it authenticates only requests that use data encryption standard (DES) credentials. Requests with no credentials are assigned to the nobody class and have whatever access rights have been granted to that class. Requests that use invalid DES credentials are retried. After repeated failure to obtain a valid DES credential, requests with invalid credentials fail with an authentication error. (A credential might not be valid for a variety of reasons, such as the principal making the request is not logged in through <b>keylogin</b> on that machine, the clocks are out of sync, there is a key mismatch, and so on.) |

## NIS+ Authentication and credentials

NIS+ credentials authenticate the identity of each principal requesting an NIS+ service or access to an NIS+ object.

The NIS+ credential or authorization process is an implementation of the Secure RPC system.

The credential or authentication system prevents someone from assuming another's identity. That is, it prevents someone with root privileges on one machine from using the **su** command to assume the identity of a second user who is either not logged in at all or logged in on another machine and then accessing NIS+ objects with the second user's NIS+ access privileges.

**Note:** NIS+ cannot prevent someone who knows another user's login password from assuming that other user's identity and the other user's NIS+ access privileges. Nor can NIS+ prevent a user with root privileges from assuming the identity of another user who is currently logged in on the *same* machine.

After a server authenticates a principal, it then checks the NIS+ object that the principal wants to access to verify what operations that principal is authorized to perform. (For further information about authorization, see "NIS+ authorization and access" on page 278.)

### ***User and machine credentials:***

There are several different credential types for *users* and *machines*

For the basic types of principal, *users* and *machines*, the following different types of credentials exist:

#### **User credentials**

When someone is logged in to an NIS+ client as a regular user, requests for NIS+ services include that person's user credentials.

#### **Machine credentials**

When a user is logged in to an NIS+ client as root user, request for services use the client workstation's credentials.

### ***DES versus local credentials:***

NIS+ principals can have DES or local credentials.

#### ***DES credentials:***

Data Encryption Standard (DES) credentials provide secure authentication.

When this guide refers to NIS+ checking a credential to authenticate an NIS+ principal, it is the DES credential that NIS+ is validating.

**Note:** Using DES credentials is only one method of achieving authentication. Do not equate DES credentials with NIS+ credentials.

Each time a principal requests an NIS+ service or access to an NIS+ object, the software uses the credential information stored for that principal to generate a credential for that principal. DES credentials are generated from information created for each principal by an NIS+ administrator, as explained in the Administering NIS+ Credentials section in the *AIX Version 6.1 Network Information Services (NIS and NIS+) Guide*.

- When the validity of a principal's DES credential is confirmed by NIS+, that principal is *authenticated*.
- A principal must be authenticated before being placed in the owner, group, or world authorization classes. In other words, you must have a valid DES credential in order to be placed in one of those classes. (Principals without a valid DES credential are automatically placed in the nobody class.)
- DES credential information is always stored in the cred table of the principal's home domain, regardless of whether that principal is a client user or a client workstation.

#### *Local credentials:*

Local credentials are a map between a user's user ID number and their NIS+ principal name, which includes their home domain name.

When users log in, the system looks up their local credential, which identifies their home domain where their DES credential is stored. The system uses that information to get the user's DES credential information.

When users log in to a remote domain, those requests use their local credential, which points back to their home domain. NIS+ then queries the user's home domain for that user's DES credential information. This allows a user to be authenticated in a remote domain even though the user's DES credential information is not stored in that domain. The following figure illustrates this concept.

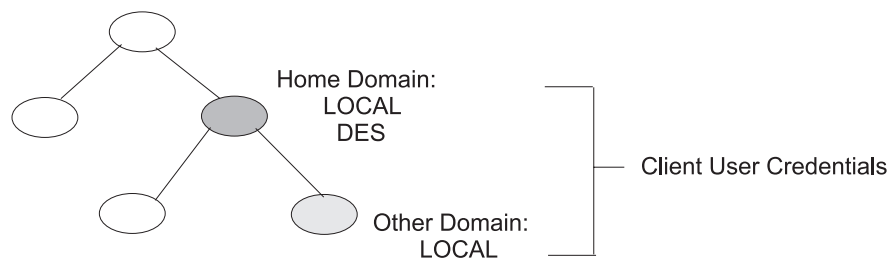

*Figure 16. Credential and Domains*

This illustration shows a domain hierarchy. The user's home domain has local and DES credentials. The subdomain only has local credentials. Home and the subdomain are labeled Client User Credentials.

Local credential information can be stored in any domain. To log in to a remote domain and be authenticated, a client user *must* have a local credential in the cred table of the remote domain. If a user does not have a local credential in a remote domain the user is trying to access, NIS+ cannot locate the user's home domain to obtain the user's DES credential. In such a case, the user would not be authenticated and would be placed in the nobody class.

#### *User types and credential types:*

A user can have both types of credential, but a machine can *only* have a DES credential.

Root cannot have NIS+ access, as root, to other machines because the root UID of every machine is always zero. If root (UID=0) of machine A tried to access machine B as root user, that conflicts with machine B's already existing root (UID=0). Thus, a local credential is not appropriate for a client *workstation*; it is allowed only for a client *user*.

### **NIS+ authorization and access**

The basic purpose of NIS+ authorization is to specify the access rights that each NIS+ principal has for each NIS+ object and service.

After the principal making an NIS+ request is authenticated, NIS+ places that principal in an authorization class. The access rights (permissions) that specify which operations a principal may do with a given NIS+ object are assigned on a class basis. In other words, one authorization class may have certain access rights while a different class has different rights.

Authorization classes are owner, group, world, and nobody. Access rights are create, destroy, modify, and read.

#### ***Authorization classes:***

NIS+ objects do not grant access rights directly to NIS+ principals.

NIS+ objects grant access rights to the following *classes* of principal:

#### **Owner**

The principal who happens to be the object's owner gets the rights granted to the owner class.

**Group** Each NIS+ object has one group associated with it. The members of an object's group are specified by the NIS+ administrator. The principals who belong to the object's group class get the rights granted to the group class. (In this context, *groups* refers to NIS+ groups, and not operating system or net groups. For a description of NIS+ groups, see "Group class" on page 279.

**World** The world class encompasses all NIS+ principals that a server has been able to authenticate. (That is, everyone who has been authenticated but who is not in either the owner or group classes.)

#### **Nobody**

All principals belong to the nobody class, including those who are not authenticated.

The following figure illustrates the class relationship:

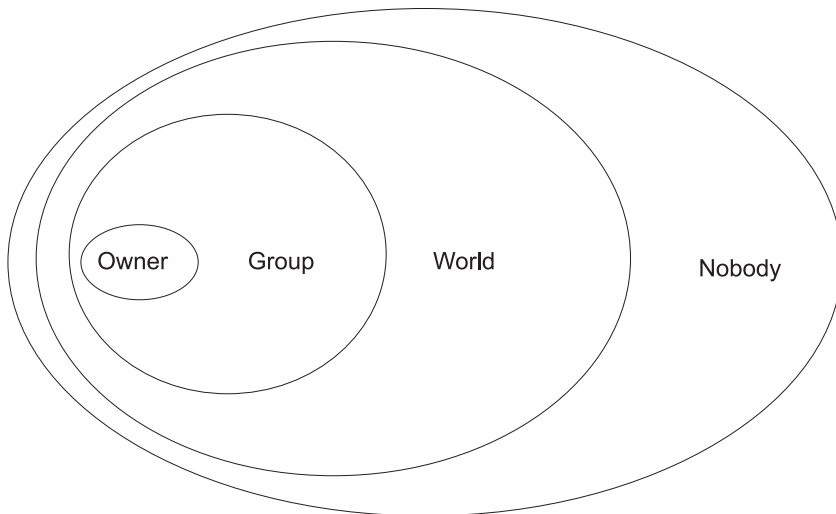

Figure 17. Authorization Classes

This illustration shows a series of ovals within ovals that represents the relationship between authorization classes. The smallest oval is Owner, encompassed by a larger oval labeled Group, encompassed by an oval labeled World, encompassed by an oval labeled Nobody.

For any NIS+ request, the system determines which class the requesting principal belongs to and the principal can then use whatever access rights belong to that class.

An object can grant any combination of access rights to each of these classes. Normally, however, a higher class is assigned the same rights as all the lower classes, as well as possible additional rights.

For instance, an object could grant read access to the nobody and world classes, both read and modify access to the group class, and read, modify, create, and destroy access to the owner class.

The following section describes the authorization classes in detail:

*Owner class:*

The owner is a *single* NIS+ principal.

A principal making a request for access to an NIS+ object must be authenticated (present a valid DES credential) before being granted owner-access rights.

By default, an object's owner is the principal that created the object. However, an object's owner can cede ownership to another principal by two different methods:

- The principal specifies a different owner at the time the object is created (see the Administering NIS+ Access Rights section in the *AIX Version 6.1 Network Information Services (NIS and NIS+) Guide*).
- The principal changes the ownership of the object after it is created (see the Administering NIS+ Access Rights section in the *AIX Version 6.1 Network Information Services (NIS and NIS+) Guide*).

After a principal cedes ownership, that principal cedes all owner's access rights to the object and keeps only the rights the object assigns to either the group, the world, or nobody.

*Group class:*

The object's group is a *single* NIS+ group. (In this context, *group* refers to NIS+ groups, and not operating system or net groups.)

A principal making a request for access to an NIS+ object must be authenticated (present a valid DES credential) and belong to the group before being granted group-access rights.

An NIS+ group is a collection of NIS+ principals, grouped together as a convenience for providing access to the namespace. The access rights granted to an NIS+ group apply to all the principals that are members of that group. (An object's owner, however, does not need to belong to the object's group.)

When an object is created, the creator can opt for a default group. A nondefault group can be specified either when the object is created or at any time later.

Information about NIS+ groups is stored in NIS+ group **objects**, under the `groups_dir` subdirectory of every NIS+ domain. (Note that information about NIS+ groups is not stored in the NIS+ group table. That table stores information about operating system groups.) Instructions for administering NIS+ groups are provided in the Administering NIS+ Groups section in the *AIX Version 6.1 Network Information Services (NIS and NIS+) Guide*.

#### *World class:*

The world class contains all NIS+ principals that are authenticated by NIS+; that is, all members in the owner and group class, as well as all other principals who present a valid DES credential.

Access rights granted to the world class apply to all authenticated principals.

#### *Nobody class:*

The nobody class contains all principals, even those without a valid DES credential.

#### *Authorization classes and the NIS+ object hierarchy:*

NIS+ security applies authorization classes independently to a hierarchy of objects.

Directory objects are the top level of the default hierarchy, then group or table objects, then columns, then entries. The following definitions provide more information about each level:

#### **Directory level**

Each NIS+ domain contains two NIS+ directory objects: `groups_dir` and `org_dir`. Each `groups_dir` directory object contains various groups. Each `org_dir` directory object contains various tables.

#### **Group or table level**

Groups contain individual entries and possibly other groups. Tables contain both columns and individual entries.

#### **Column level**

Each table has one or more columns.

#### **Entry (row) level**

Each group or table has one or more entries.

The four authorization classes apply at each level. Thus, a directory object has an owner and a group. Each table within a directory object has its own owner and group, which can be different from the owner and group of the directory object. Within a table, a column or an entry can have its own owner or group, which can be different from the owner and group of the table as a whole or of the directory object as a whole.

#### ***NIS+ access rights:***

NIS+ objects specify access rights for NIS+ principals in the same way that operating system files specify permissions for operating system users.



Access rights specify the types of operations that NIS+ principals are allowed to perform on NIS+ objects. (You can examine these by using the **niscat -o** command.)

NIS+ operations vary among different types of objects, but all operations fall into one of the following access-rights categories: read, modify, create, and destroy.

**Read** A principal with read rights to an object can view the contents of that object.

**Modify**

A principal with modify rights to an object can change the contents of that object.

**Destroy**

A principal with destroy rights to an object can destroy or delete the object.

**Create**

A principal with create rights to a higher-level object can create new objects within that level. If you have create rights to a NIS+ directory object, you can create new tables within that directory. If you have create rights to a NIS+ table, you can create new columns and entries within that table.

Every communication from an NIS+ client to an NIS+ server is a request to perform one of these operations on a specific NIS+ object. For instance, when an NIS+ principal requests the IP address of another workstation, it is effectively requesting read access to the hosts table object, which stores that type of information. When a principal asks the server to add a directory to the NIS+ namespace, it is actually requesting modify access to the directory's parent object.

These rights logically evolve down from directory to table to table column and entry levels. For example, to create a new table, you must have create rights for the NIS+ directory object where the table will be stored. When you create that table, you become its default owner. As owner, you can assign yourself create rights to the table, which allows you to create new entries in the table. If you create new entries in a table, you become the default owner of those entries. As table owner, you can also grant table-level create rights to others. For example, you can give your table's group class table-level create rights. In that case, any member of the table's group can create new entries in the table. The individual member of the group who creates a new table entry becomes the default owner of that entry.

## NIS+ Security and administrative rights

NIS+ does not enforce any requirement that there be a single NIS+ administrator. Whoever has administrative rights over an object (that is, the authority to create, destroy, and for some objects, modify rights) is considered to be an NIS+ administrator for that object.

Whoever creates an NIS+ object sets the initial access rights to that object. If the creator restricts administrative rights to the object's owner (initially the creator), only the owner has administrative power over that object. On the other hand, if the creator grants administrative rights to the object's group, then everyone in that group has administrative power over that object.

Theoretically, you could grant administrative rights to the world class, or even the nobody class. The software allows you to do that. But granting administrative rights beyond the group class effectively nullifies NIS+ security. Thus, if you grant administrative rights to either the world or the nobody class, you are, in effect, defeating the purpose of NIS+ security.

## NIS+ security reference

The following commands are used to administer passwords, credentials, and keys.

**chkey** Changes a principal's secure RPC key pair. Unless you want to re-encrypt your current private key with a new password, use the **passwd** command instead. The **chkey** command does not affect the principal's entry either in the **passwd** table or **/etc/passwd** file.

**keylogin**

Decrypts and stores a principal's secret key with the **keyserv**.

**keylogout**

Deletes stored secret key from keysevr.

**keysevr**

Enables the server for storing private encryption keys.

**newkey**

Creates a new key pair in public-key database.

**nisaddcred**

Creates credentials for NIS+ principals.

**nisupdkeys**

Updates public keys in directory objects.

**passwd**

Changes and administers principal's password.

## Network File System security

The Network File System (NFS) is a widely available technology that allows data to be shared between various hosts on a network.

Beginning with the release of AIX 5.3.0, NFS also supports the use of Kerberos 5 authentication in addition to DES. Kerberos 5 security is provided under a protocol mechanism called RPCSEC\_GSS.

In addition to the standard UNIX authentication system, NFS provides a means to authenticate users and machines in networks on a message-by-message basis. This additional authentication system uses Data Encryption Standard (DES) encryption and public key cryptography.

Beginning with the release of AIX 5L™ Version 5.2, NFS also supports the use of Kerberos 5 authentication in addition to DES. Kerberos 5 security is provided under a protocol mechanism called RPCSEC\_GSS. For a description of how to administer and use Kerberos authentication with NFS, see the *NFS Administration Guide*.

### General guidelines for securing Network File System

There are several guidelines that help you secure the Network File System (NFS).

- Ensure that the latest software patches are installed. Patches that address security issues should be considered especially important. All software in a given infrastructure should be maintained. For example, installing patches in an operating system but failing to install patches on a Web server may provide an attacker with a way to attach your environment that could have been avoided if the Web server been updated as well. To subscribe to IBM System p™ Security Alerts for information about the latest available security information, visit the following Web address: <http://www14.software.ibm.com/webapp/set2/subscriptions/pqvcmj.d>.
- Configure the NFS server to export file systems with the least amount of privileges necessary. If users only need to read from a file system, they should not be able to write to the file system. This can mitigate an attempt to overwrite important data, modify configuration files, or write malicious executable code to an exported file system. Specify privileges using SMIT or by directly editing the **/etc/exports** file.
- Configure the NFS server to export file systems explicitly for the users who should have access to it. Most implementations of NFS will allow you to specify which NFS clients should have access to a given file system. This will mitigate attempts by unauthorized users to access file systems. In particular, do not configure a NFS server to export a file system to itself.
- Exported file systems should be in their own partitions. An attacker could cause system degradation by writing to an exported file system until it is full. This may make the file system unavailable to other applications or users that needed it.

- Do not allow NFS clients to access the file system with root user credentials or unknown user credentials. Most implementations of NFS can be configured to map requests from a privileged or unknown user to an unprivileged user. This will avert scenarios where an attacker tries to access files and perform file operations as a privileged user.
- Do not allow NFS clients to run suid and sgid programs on exported file systems. This will prevent NFS clients from executing malicious code with privileges. If the attacker is able to make the executable owned by a privileged owner or group, significant harm can be done to the NFS server. This can be done by specifying the **mknfsmnt -y** command option.
- Use Secure NFS. Secure NFS uses DES encryption to authenticate hosts involved in RPC transactions. RPC is a protocol used by NFS to communicate requests between hosts. Secure NFS will mitigate attempts by an attacker to spoof RPC requests by encrypting the time stamp in the RPC requests. A receiver successfully decrypting the time stamp and confirm that it is correct serves as confirmation that the RPC request came from a trusted host.
- If NFS is not needed, turn it off. This will reduce the number of possible attack vectors available to an intruder.

Beginning with AIX 5.3 and AIX Version 6.1, NFS also supports the use of the AES encryption type with Kerberos 5 authentication in addition to Triple DES and Single DES. For a description of how to configure Kerberos 5 to use the AES encryption type, see the NFS System Management guide. The AIX 5.3 NFS V4 implementation supports the following types of encryption:

- des-cbc-crc
- des-cbc-md4
- des-cbc-md5
- des3-cbc-sha1
- aes256-cts

For more information about implementing the items discussed, refer to the following information:

- **AIX 5L Version 5.1 information**
  - NFS Installation and Configuration: [http://publibn.boulder.ibm.com/doc\\_link/en\\_US/a\\_doc\\_lib/aixbman/commadm/nfs\\_install.htm](http://publibn.boulder.ibm.com/doc_link/en_US/a_doc_lib/aixbman/commadm/nfs_install.htm)
  - exports File for NFS: [http://publibn.boulder.ibm.com/doc\\_link/en\\_US/a\\_doc\\_lib/files/aixfiles/exports.htm](http://publibn.boulder.ibm.com/doc_link/en_US/a_doc_lib/files/aixfiles/exports.htm)
  - Secure NFS: [http://publibn.boulder.ibm.com/doc\\_link/en\\_US/a\\_doc\\_lib/aixbman/commadm/nfs\\_secure.htm](http://publibn.boulder.ibm.com/doc_link/en_US/a_doc_lib/aixbman/commadm/nfs_secure.htm)
  - mknfsmnt Command: [http://publibn.boulder.ibm.com/doc\\_link/en\\_US/a\\_doc\\_lib/cmds/aixcmds3/mknfsmnt.htm](http://publibn.boulder.ibm.com/doc_link/en_US/a_doc_lib/cmds/aixcmds3/mknfsmnt.htm)
- **AIX 5L Version 5.2 information**
  - NFS Installation and Configuration: [http://publib16.boulder.ibm.com/pseries/en\\_US/aixbman/commadm/nfs\\_install.htm](http://publib16.boulder.ibm.com/pseries/en_US/aixbman/commadm/nfs_install.htm)
  - exports File for NFS: [http://publib16.boulder.ibm.com/pseries/en\\_US/files/aixfiles/exports.htm](http://publib16.boulder.ibm.com/pseries/en_US/files/aixfiles/exports.htm)
  - Network File System (NFS) Security: [http://publib16.boulder.ibm.com/pseries/en\\_US/aixbman/security/secure\\_nfs.htm](http://publib16.boulder.ibm.com/pseries/en_US/aixbman/security/secure_nfs.htm)
  - mknfsmnt Command: [http://publib16.boulder.ibm.com/pseries/en\\_US/cmds/aixcmds3/mknfsmnt.htm](http://publib16.boulder.ibm.com/pseries/en_US/cmds/aixcmds3/mknfsmnt.htm)

## Network File System authentication

NFS uses the DES algorithm for different purposes. NFS uses DES to encrypt a time stamp in the remote procedure call (RPC) messages sent between NFS servers and clients. This encrypted time stamp authenticates machines just as the token authenticates the sender.

Because NFS can authenticate every RPC message exchanged between NFS clients and servers, this provides an additional, optional level of security for each file system. By default, file systems are exported

with the standard UNIX authentication. To take advantage of this additional level of security, you can specify the secure option when you export a file system.

### **Public key cryptography for secure Network File System:**

Both the public key and the secret key of the user are stored and indexed by the net name in the **publickey.byname** map.

The secret key is DES-encrypted with the user login password. The **keylogin** command uses the encrypted secret key, decrypts it with the login password, then gives it to a secure local key server to save for use in future RPC transactions. Users are not aware of their public and secret keys because the **yppasswd** command, in addition to changing the login password, generates the public and secret keys automatically.

The **keyserv** daemon is an RPC service that runs on each NIS and NIS+ machine. For information on how NIS+ uses **keyserv**, see *AIX Version 6.1 Network Information Services (NIS and NIS+) Guide*. Within NIS, **keyserv** runs the following public key subroutines:

- **key\_setsecret** subroutine
- **key\_encryptsession** subroutine
- **key\_decryptsession** subroutine

The **key\_setsecret** subroutine tells the key server to store the secret key of the user ( $SK_A$ ) for future use; it is normally called by the **keylogin** command. The client program calls the **key\_encryptsession** subroutine to generate the encrypted conversation key, which is passed in the first RPC transaction to a server. The key server looks up the server public key and combines it with the secret key of the client (set up by a previous **key\_setsecret** subroutine) to generate the common key. The server asks the key server to decrypt the conversation key by calling the **key\_decryptsession** subroutine.

Implicit in these subroutine calls is the name of the caller, which must be authenticated in some manner. The key server cannot use DES authentication to do this, because it would create a deadlock. The key server solves this problem by storing the secret keys by the user ID (UID) and only granting requests to local root processes. The client process then runs a root-user-owned **setuid** subroutine that makes the request on the part of the client, telling the key server the real UID of the client.

### **Network File System authentication requirements:**

Secure NFS authentication is based on the ability of a sender to encrypt the current time, which the receiver can then decrypt and check against its own clock.

This process has the following requirements:

- The two agents must agree on the current time.
- The sender and receiver must be using the same DES encryption key.

#### *Agreeing on the current time:*

If the network uses time synchronization, the timed daemon keeps the client and server clocks synchronized. If not, the client computes the proper time stamps based on the server clock.

To do this, the client determines the server time before starting the RPC session, and then computes the time difference between its own clock and that of the server. The client then adjusts its time stamp accordingly. If, during the course of an RPC session, the client and server clocks become unsynchronized to the point where the server begins rejecting the client requests, the client will redetermine the server time.

#### *Using the same DES key:*

The client and server compute the same DES encryption key by using public key cryptography.

For any client A and server B, a key called the *common key* can only be deduced by A and B. This key is . The client derives the common key by computing the following formula:

$$K_{AB} = PK_B^{SK_A}$$

where  $K$  is the common Key,  $PK$  is the Public Key, and  $SK$  is the Secret Key, and each of these keys is a 128-bit number. The server derives the same common key by computing the following formula:

$$K_{AB} = PK_A^{SK_B}$$

Only the server and client can calculate this common key since doing so requires knowing one secret key or the other. Because the common key has 128 bits, and DES uses a 56-bit key, the client and server extract 56 bits from the common key to form the DES key.

**Network File System authentication process:**

When a client wants to talk to a server, it randomly generates a key used for encrypting the time stamps. This key is known as the *conversation key* ( $CK$ ).

The client encrypts the conversation key using the DES common key (described in Authentication Requirements) and sends it to the server in the first RPC transaction. This process is illustrated in the following figure.

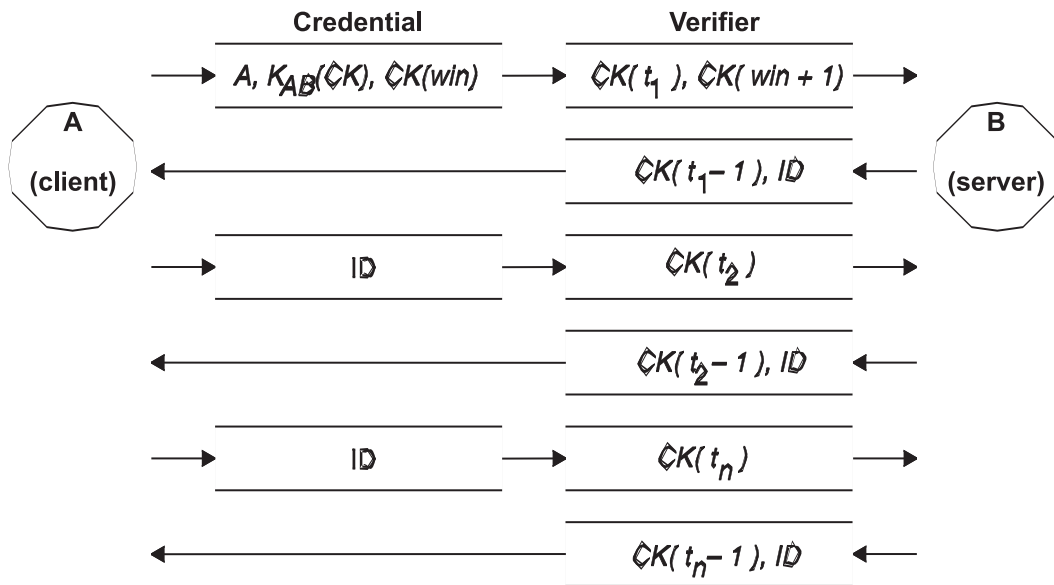

Figure 18. Authentication Process. This figure illustrates the authentication process.

This figure shows client A connecting to server B. The term  $K(CK)$  means  $CK$  is encrypted with the DES common key  $K$ . In its first request, the client RPC credential contains the client name ( $A$ ), the conversation key ( $CK$ ), and the variable called *win* (window) encrypted with  $CK$ . (The default window size is 30 minutes.) The client verifier in the first request contains the encrypted time stamp and an encrypted verifier of the specified window,  $win + 1$ . The window verifier makes guessing the right credential much more difficult, and increases security.

After authenticating the client, the server stores the following items in a credential table:

- Client name, *A*
- Conversation key, *CK*
- Window
- Time stamp

The server only accepts time stamps that are chronologically greater than the last one seen, so any replayed transactions are guaranteed to be rejected. The server returns to the client in the verifier an index ID into the credential table, plus the client time stamp minus 1, encrypted by *CK*. The client knows that only the server could have sent such a verifier, because only the server knows what time stamp the client sent. The reason for subtracting 1 from the time stamp is to ensure that it is not valid and cannot be reused as a client verifier. After the first RPC transaction, the client sends just its ID and an encrypted time stamp to the server, and the server sends back the client time stamp minus 1, encrypted by *CK*.

### **Naming network entities for DES authentication**

DES authentication does its naming by using net names. For information on how NIS+ handles DES authentication, see the *AIX Version 6.1 Network Information Services (NIS and NIS+) Guide*.

A *net name* is a string of printable characters to authenticate. The public and secret keys are stored on a per-net-name rather than a per-user-name basis. The **netid.byname** NIS map maps the net name into a local UID and group-access list.

User names are unique within each domain. Net names are assigned by concatenating the operating system and user ID with the NIS and Internet domain names. A good convention for naming domains is to append the Internet domain name (com, edu, gov, mil) to the local domain name.

Network names are assigned to machines as well as to users. A net name of a machine is formed much like that of a user. For example, a machine named `hal` in the `eng.xyz.com` domain has the net name `unix.hal@eng.xyz.com`. Correct authentication of machines is important for diskless machines that need full access to their home directories over the network.

To authenticate users from any remote domain, make entries for them in two NIS databases. One is an entry for their public and secret keys; the other is for their local UID and group-access list mapping. Users in the remote domain can then access all of the local network services, such as the NFS and remote logins.

### **The `/etc/publickey` file**

The `/etc/publickey` file contains names and public keys, which NIS and NIS+ use to create the publickey map.

The publickey map is used for secure networking. Each entry in the file consists of a network user name (which refers to either a user or a host name), followed by the user public key (in hexadecimal notation), a colon, and the user-encrypted secret key (also in hexadecimal notation). By default, the only user in the `/etc/publickey` file is the user `nobody`.

Do not use a text editor to alter the `/etc/publickey` file because the file contains encryption keys. To alter the `/etc/publickey` file, use either the **chkey** or **newkey** commands.

### **Public key systems booting considerations**

When restarting a machine after a power failure, all of the stored secret keys are lost, and no process can access secure network services, such as mounting an NFS. Root processes could continue if there were someone to enter the password that decrypts the secret key of the root user. The solution is to store the root-user decrypted secret key in a file that the key server can read.

Not all **setuid** subroutine calls operate correctly. For example, if a **setuid** subroutine is called by owner A, and owner A has not logged into the machine since it started, the subroutine cannot access any secure network services as A. However, most **setuid** subroutine calls are owned by the root user, and the root user secret key is always stored at startup time.

## Secure Network File System performance considerations

There are several ways that secure NFS affects system performance.

- Both the client and server must compute the common key. The time it takes to compute the common key is about one second. As a result, it takes about two seconds to establish the initial RPC connection, because both client and server have to perform this operation. After the initial RPC connection, the key server caches the results of previous computations, and so it does not have to recompute the common key every time.
- Each RPC transaction requires the following DES encryption operations:
  1. The client encrypts the request time stamp.
  2. The server decrypts it.
  3. The server encrypts the reply time stamp.
  4. The client decrypts it.

Because system performance can be reduced by secure NFS, weigh the benefits of increased security against system-performance requirements.

## Secure Network File System checklist

This checklist helps ensure that secure NFS operates correctly.

- When mounting a file system with the **-secure** option on a client, the server name must match the server host name in the **/etc/hosts** file. If a name server is being used for host-name resolution, make sure the host information returned by the name server matches the entry in the **/etc/hosts** file. Authentication errors result if these names do not match because the net names for machines are based on the primary entries in the **/etc/hosts** file and keys in the **publickey** map are accessed by net name.
- Do not mix secure and nonsecure exports and mounts. Otherwise, file access might be determined incorrectly. For example, if a client machine mounts a secure file system without the **-secure** option or mounts a nonsecure system with the **-secure** option, users have access as **nobody**, rather than as themselves. This condition also occurs if a user unknown to NIS or NIS+ attempts to create or modify files on a secure file system.
- Because NIS must propagate a new map after each use of the **chkey** and **newkey** commands, use these commands only when the network is lightly loaded.
- Do not delete the **/etc/keystore** file or the **/etc/rootkey** file. If you reinstall, move, or upgrade a machine, save the **/etc/keystore** and **/etc/rootkey** files.
- Instruct users to use the **yppasswd** command rather than the **passwd** command to change passwords. Doing so keeps passwords and private keys synchronized.
- Because the **login** command does not retrieve keys out of the publickey map for the **keyserv** daemon, the user must run the **keylogin** command. You may want to place the **keylogin** command in each user **profile** file to run the command automatically during login. The **keylogin** command requires users to enter their password again.
- When you generate keys for the root user at each host with either the **newkey -h** or **chkey** command, you must run the **keylogin** command to pass the new keys to the **keyserv** daemon. The keys are stored in the **/etc/rootkey** file, which is read by the **keyserv** daemon each time the daemon is started.
- Periodically verify that the **yppasswdd** and **ypupdated** daemons are running on the NIS master server. These daemons are necessary for maintaining the publickey map.
- Periodically verify that the **keyserv** daemon is running on all machines using secure NFS.

## Configuring secure Network File System

To configure secure NFS on NIS master and slave servers, use the Web-based System Manager Network application or use the following procedure.

For information about using NFS with NIS+, see *AIX Version 6.1 Network Information Services (NIS and NIS+) Guide*.

1. On the NIS master server, create an entry for each user in the NIS `/etc/publickey` file by using the **newkey** command as follows:
  - For a regular user, type:  
smit newkey
  - OR  
newkey -u username
  - For a root user on a host machine, type:  
newkey -h hostname
  - Alternatively, users can establish their own public keys by using the **chkey** or **newkey** commands.
2. Create the NIS publickey map by following the instructions in *AIX Version 6.1 Network Information Services (NIS and NIS+) Guide*. The corresponding NIS **publickey.byname** map resides only on the NIS servers.
3. Uncomment the following stanzas in the `/etc/rc.nfs` file:

```
#if [-x /usr/sbin/keyserv]; then
startsrc -s keyserv
#fi
#if [-x /usr/lib/netsvc/yp/rpc.yppupdated -a -d /etc/yp/`domainname`]; then
startsrc -s yppupdated
#fi
#DIR=/etc/passwd
#if [-x /usr/lib/netsvc/yp/rpc.yppasswdd -a -f $DIR/passwd]; then
startsrc -s yppasswdd
#fi
```

4. Start the **keyserv**, **yppupdated**, and **yppasswdd** daemons by using the **startsrc** command.

To configure secure NFS on NIS clients, start the **keyserv** daemon by using the **startsrc** command.

## Exporting a file system using Secure Network File System

You can export a secure NFS using the Web-based System Manager Network application or by using one of the following procedures.

- To export a secure NFS file system using SMIT, perform the following steps:
  1. Verify that NFS is already running by running the **lssrc -g nfs** command. The output indicates that the **nfsd** and the **rpc.mountd** daemons are active.
  2. Verify that the publickey map exists and that the **keyserv** daemon is running. For more information, see “Configuring secure Network File System.”
  3. Run the **smit mknfsexp** fast path.
  4. Specify the appropriate values for the **PATHNAME** of directory to export, **MODE** to export directory, and **EXPORT** directory now, system restart or both fields. Specify yes for the Use **SECURE** option field.
  5. Specify any other optional characteristics, or accept the default values.
  6. Exit SMIT. If the `/etc/exports` file does not exist, it will be created.
  7. Repeat steps 3 through 6 for each directory you want to export.
- To export a secure NFS file system by using a text editor, perform the following steps:
  1. Open the `/etc/exports` file with your favorite text editor.



2. Create an entry for each directory to be exported, using the full path name of the directory. List each directory to be exported starting in the left margin. No directory should include any other directory that is already exported. See the **/etc/exports** file documentation for a description of the full syntax for entries in the **/etc/exports** file, including how to specify the secure option.

3. Save and close the **/etc/exports** file.

4. If NFS is currently running, type:

```
/usr/sbin/exportfs -a
```

Using the **-a** option with the **exportfs** command sends all information in the **/etc/exports** file to the kernel.

- To export an NFS file system temporarily (that is, without changing the **/etc/exports** file), type:

```
exportfs -i -o secure /dirname
```

where *dirname* is the name of the file system you want to export. The **exportfs -i** command specifies that the **/etc/exports** file is not to be checked for the specified directory, and all options are taken directly from the command line.

## Mounting a file system using Secure Network File system

You can explicitly mount a secure NFS directory.

To mount a secure NFS directory explicitly, perform the following steps:

1. Verify that the NFS server has exported the directory by running the command:

```
showmount -e ServerName
```

where *ServerName* is the name of the NFS server. This command displays the names of the directories currently exported from the NFS server. If the directory you want to mount is not listed, export the directory from the server.

2. Establish the local mount point by using the **mkdir** command. For NFS to complete a mount successfully, a directory that acts as the mount point (or placeholder) of an NFS mount must be present. This directory should be empty. This mount point can be created like any other directory, and no special attributes are needed.
3. Verify that the publickey map exists and that the keysevr daemon is running. For more information, see “Configuring secure Network File System” on page 288.
4. Type

```
mount -o secure ServerName:/remote/directory /local/directory
```

where *ServerName* is the name of the NFS server, */remote/directory* is the directory on the NFS server you want to mount, and */local/directory* is the mount point on the NFS client.

**Note:** Only the root user can mount a secure NFS.

## Enterprise identity mapping

Today’s network environments are made up of a complex group of systems and applications, resulting in the need to manage multiple user registries. Dealing with multiple user registries quickly grows into a large administrative problem that affects users, administrators, and application developers. Enterprise Identity Mapping (EIM) allows administrators and application developers to address this problem.

This section describes the problems, outlines current industry approaches, and explains the EIM approach.

### Managing multiple user registries

Many administrators manage networks that include different systems and servers, each with a unique way of managing users through various user registries.

In these complex networks, administrators are responsible for managing each user's identities and passwords across multiple systems. Additionally, administrators often must synchronize these identities and passwords. Users are burdened with remembering multiple identities and passwords and with keeping them synchronized. Because user and administrator overhead in this environment is expensive, administrators often spend valuable time troubleshooting failed login attempts and resetting forgotten passwords instead of managing the enterprise.

The problem of managing multiple user registries also affects application developers who want to provide multiple-tier or heterogeneous applications. Customers have important business data spread across many different types of systems, with each system possessing its own user registries. Consequently, developers must create proprietary user registries and associated security semantics for their applications. Although this solves the problem for the application developer, it increases the overhead for users and administrators.

### **Current approaches to enterprise identity mapping**

Several current industry approaches for solving the problem of managing multiple user registries are available, but they all provide incomplete solutions. For example, Lightweight Directory Access Protocol (LDAP) provides a distributed user registry solution. However, to use solutions such as LDAP, administrators must manage yet another user registry and security semantics or replace existing applications that are built to use those registries.

Using this type of solution, administrators must manage multiple security mechanisms for individual resources, thereby increasing administrative overhead and potentially increasing the likelihood of security exposures. When multiple mechanisms support a single resource, the chances of changing the authority through one mechanism and forgetting to change the authority for one or more of the other mechanisms is much higher. For example, a security exposure can result when a user is appropriately denied access through one interface, but allowed access through one or more other interfaces.

After completing this work, administrators find that they have not completely solved the problem. Generally, enterprises have invested too much money in current user registries and in their associated security semantics to make using this type of solution practical. Creating another user registry and associated security semantics solves the problem for the application provider, but not the problems for users or administrators.

Another solution is to use a single sign-on approach. Several products are available that allow administrators to manage files that contain all of a user's identities and passwords. However, this approach has several weaknesses:

- It addresses only one of the problems that users face. Although it allows users to sign on to multiple systems by supplying one identity and password, the user is still required to have passwords on other systems, or the need to manage these passwords.
- It introduces a new problem by creating a security exposure because clear-text or decryptable passwords are stored in these files. Passwords should never be stored in clear-text files or be easily accessible by anyone, including administrators.
- It does not solve the problems of third-party application developers that provide heterogeneous, multiple-tier applications. They must still provide proprietary user registries for their applications.

Despite these weaknesses, some enterprises use these solutions because they provide some relief for the multiple user registry problems.

### **Enterprise identity mapping usage**

The EIM architecture describes the relationships between individuals or entities (such as file servers and print servers) in the enterprise and the many identities that represent them within an enterprise. In addition, EIM provides a set of APIs that allow applications to ask questions about these relationships.

For example, given a person's user identity in one user registry, you can determine which identity in another user registry represents that same person. If the user has authenticated with one identity and you can map that identity to the appropriate identity in another user registry, the user does not need to provide credentials for authentication again. You need only know which identity represents that user in another user registry. Therefore, EIM provides a generalized identity-mapping function for the enterprise.

The ability to map between a user's identities in different registries provides many benefits. Primarily, applications can have the flexibility of using one registry for authentication while using an entirely different registry for authorization. For example, an administrator could map an SAP identity to access SAP resources.

Identity mapping requires that administrators perform the following steps:

1. Create EIM identifiers that represent people or entities in their enterprise.
2. Create EIM registry definitions that describe the existing user registries in their enterprise.
3. Define the relationship between the user identities in those registries to the EIM identifiers that they created.

No code changes are required to existing registries. Mappings are not required for all identities in a user registry. EIM allows one-to-many mappings (in other words, a single user with more than one identity in a single user registry). EIM also allows many-to-one mappings (in other words, multiple users sharing a single identity in a single user registry, which although supported is not advised for security reasons). An administrator can represent any user registry of any type in EIM.

EIM does not require copying existing data to a new repository and trying to keep both copies synchronized. The only new data that EIM introduces is the relationship information. Administrators manage this data in an LDAP directory, which provides the flexibility of managing the data in one place and having replicas wherever the information is used.

For more information about Enterprise Identity Mapping, refer to the following Web sites:

- <http://publib.boulder.ibm.com/eserver/>
- <http://www.ibm.com/servers/eserver/security/eim/>

## Kerberos

Kerberos is a network authentication service that provides a means of verifying the identities of principals on physically insecure networks. Kerberos provides mutual authentication, data integrity and privacy under the realistic assumption that network traffic is vulnerable to capture, examination, and substitution.

Kerberos tickets are credentials that verify your identity. There are two types of tickets: a *ticket-granting ticket* and a *service ticket*. The ticket-granting ticket is for your initial identity request. When logging into a host system, you need something that verifies your identity, such as a password or a token. After you have the ticket-granting ticket, you can then use your ticket-granting ticket to request service tickets for specific services. This two-ticket method is called the *trusted third-party* of Kerberos. Your ticket-granting ticket authenticates you to the Kerberos server, and your service ticket is your secure introduction to the service.

The trusted third-party or intermediary in Kerberos is called the *Key Distribution Center (KDC)*. The KDC issues all the Kerberos tickets to the clients.

The Kerberos database keeps a record of every principal; the record contains the name, private key, expiration date of the principal, and some administrative information about each principal. The master KDC contains the master copy of the database and passes it to slave KDCs.

This section contains the following Kerberos information:

## Secure remote commands overview

The following provides details about secure remote commands.

**Note:** Beginning with Distributed Computing Environment (DCE) version 2.2, the DCE security server can return Kerberos Version 5 tickets.

**Note:** Beginning with AIX 5.2, all the secure remote commands (rcmds) use the Kerberos Version 5 library provided by Network Authentication Service (NAS) version 1.3. In a DCE realm, the **ftp** command uses the GSSAPI library from the **libdce.a** DCE library, and in a native realm, the **ftp** command uses the GSSAPI library from NAS version 1.3. NAS version 1.3 is located on the Expansion Pack CD. The only LPP that is required is the **krb5.client.rte** fileset.

**Note:** If you are migrating to AIX 5.2 and had Kerberos Version 5 or Kerberos Version 4 installed, the installation scripts prompt the user to install **krb5.client.rte**.

The secure rcmds are **rlogin**, **rcp**, **rsh**, **telnet**, and **ftp**. These commands are known collectively as the *Standard AIX* method. (This method refers to the authentication method used by AIX 4.3 and prior releases.) The additional methods provided are Kerberos Version 5 and Kerberos Version 4.

When using the Kerberos Version 5 authentication method, the client gets a Kerberos Version 5 ticket from the DCE security server or Kerberos server. The ticket is a portion of the user's current DCE or local credentials encrypted for the TCP/IP server with which they want to connect. The daemon on the TCP/IP server decrypts the ticket. This action allows the TCP/IP server to absolutely identify the user. If the DCE or local principal described in the ticket is allowed access to the operating system user's account, the connection proceeds. The secure rcmds support Kerberos clients and servers from both Kerberos Version 5 and DCE.

In addition to authenticating the client, Kerberos Version 5 forwards the current user's credentials to the TCP/IP server. If the credentials are marked as forwardable, the client sends them to the server as a Kerberos ticket-granting ticket (TGT). On the TCP/IP server side, if a user is communicating with a DCE security server, the daemon upgrades the TGT into full DCE credentials using the **k5dcecreds** command.

The **ftp** command uses a different authentication method than the other secure rcmds. It uses the GSSAPI security mechanism to pass the authentication between the **ftp** command and the **ftpd** daemon. Using the **clear**, **safe**, and **private** subcommands, the ftp client supports data encryption.

Between operating system clients and servers, the **ftp** command allows multiple byte transfers for encrypted data connections. The standards define only single byte transfers for encrypted data connections. When connected to third-party machines and using data encryption, the **ftp** command follows the single byte transfer limit.

### **System configuration:**

For all of the secure rcmds, a system-level configuration mechanism determines which authentication methods are allowed for that system. The configuration controls both outgoing and incoming connections.

The authentication configuration consists of the **libauthm.a** library and the **lsauthent** and **chauthent** commands, that provide command line access to the **get\_auth\_methods** and **set\_auth\_methods** library routines.

The authentication method defines which method is used to authenticate a user across a network. The system supports the following authentication methods:

- Kerberos Version 5 is the most common method, as it is the basis for DCE.

- Kerberos Version 4 is used only by the `rlogin`, `rsh`, and `rcp` secure `rcmds`. It is provided to support backward compatibility only on SP™ systems. A Kerberos Version 4 ticket is not upgraded to DCE credentials.
- Standard AIX is the authentication method that is used by AIX 4.3 and prior releases.

If more than one authentication method is configured and the first method fails to connect, the client attempts to authenticate using the next authentication method configured.

Authentication methods can be configured in any order. The only exception is that Standard AIX must be the final authentication method configured, because there is no fallback option. If Standard AIX is not a configured authentication method, password authentication is not attempted and any connection attempt using this method is rejected.

You can configure the system without any authentication methods. In this case, the machine refuses all connections from and to any machine using secure `rcmds`. Also, because Kerberos Version 4 is only supported with the **`rlogin`**, **`rsh`**, and **`rcp`** commands, a system configured to use only Kerberos Version 4 does not allow connections using telnet or FTP.

### ***Kerberos Version 5 user validation:***

The Kerberos Version 5 authentication method can be used to validate a user.

When using the Kerberos Version 5 authentication method, the TCP/IP client gets a service ticket encrypted for the TCP/IP server. When the server decrypts the ticket, it has a secure method of identifying the user (by DCE or local principal). However, the server still needs to determine if this DCE or local principal is allowed access to the local account. Mapping the DCE or local principal to the local operating system account is handled by a shared library, **`libvaliduser.a`**, which has a single subroutine, called `kvalid_user`. If a different method of mapping is preferred, the system administrator must provide an alternative for the **`libvaliduser.a`** library.

### ***DCE configuration:***

To use the secure `rcmds`, two DCE principals must exist for every network interface to which they can be connected.

The two DCE principals are:

```
host/FullInterfaceName
ftp/FullInterfaceName
```

where:

```
FullInterfaceName
 Interface name and domain name
```

### ***Local configuration:***

To use the secure `rcmds`, two local principals must exist for every network interface to which they can be connected.

The two local principals are:

```
host/FullInterfaceName@Realmname
ftp/FullInterfaceName@Realmname
```

where:

```
FullInterfaceName
 Interface name and domain name
```

### *RealmName*

Name of the local Kerberos Version 5 realm

See the following sources for related information:

- The `get_auth_method` and `set_auth_method` subroutines in *AIX Version 6.1 Technical Reference: Communications Volume 2*
- The `chauthent` command in *AIX Version 6.1 Commands Reference, Volume 1*
- The `lsauthent` command in *AIX Version 6.1 Commands Reference, Volume 3*

## **Authenticating to AIX using Kerberos**

AIX provides both KRB5 and KRB5A Kerberos authentication load modules. Even though both modules do Kerberos authentication, the KRB5 load module performs Kerberos principal management, whereas the KRB5A load module does not.

The KRB5 load module uses the IBM Network Authentication Services' Kerberos database interface to manipulate the Kerberos identities and principals. Using the KRB5 load module, an AIX system administrator can manage Kerberos-authenticated users and their associated Kerberos principals by using the existing AIX user-administration commands without any change. For example, to create an AIX user, as well as a Kerberos principal associated with that user, run the **mkuser** command.

The KRB5A load module performs only authentication. The Kerberos principal management is done separately by using Kerberos principal-management tools. The KRB5A load module is used in an environment where Kerberos principals are stored on a non-AIX system and cannot be managed from AIX by using the Kerberos database interface. KRB5A is intended to be used against Microsoft Windows 2000 Active Directory server where Kerberos principal management is performed using the Active Directory account management tools and APIs.

### ***Installing and configuring the system for Kerberos integrated login using KRB5:***

Network Authentication Services (IBM Kerberos implementation) is shipped on the Expansion Pack.

To install the Kerberos Version 5 client package, install the **krb5.client.rte** fileset. To install the Kerberos Version 5 server package, install the **krb5.server.rte** fileset. To install the entire Kerberos Version 5 package, install the **krb5** package.

To avoid namespace collisions between DCE and Kerberos commands (that is, between the **klist**, **kinit**, and **kdestroy** commands), the Kerberos commands are installed in the **/usr/krb5/bin** and the **/usr/krb5/sbin** directories. You can add these directories to your PATH definition. Otherwise, to run the Kerberos commands, you must specify fully qualified command path names.

Network Authentication Services documentation is provided in the **krb5.doc.lang.pdfhtml** package, where *lang* represents the supported language.

### ***Configuring the Kerberos Version 5 KDC and kadmin servers:***

Provides information on configuring the Kerberos Version 5 KDC and kadmin servers.

**Note:** Do not install both DCE and Kerberos server software be installed on the same physical system. If you must do so, the default operational internet port numbers must be changed for either the DCE clients and server or for the Kerberos clients and server. In either case, such a change can affect interoperability with existing DCE and Kerberos deployments in your environment. For information about coexistence of DCE and Kerberos, refer to Network Authentication Services documentation.

**Note:** Kerberos Version 5 is set up to reject ticket requests from any host whose clock is not within the specified maximum clock skew of the KDC. The default value for maximum clock skew is 300

seconds (five minutes). Kerberos requires that some form of time synchronization is configured between the servers and the clients. It is recommended that you use the **xntpd** or **timed** daemons for time synchronization. To use the **timed** daemon, do the following:

1. Set up the KDC server as a time server by starting the **timed** daemon, as follows:

```
timed -M
```

2. Start the **timed** daemon on each Kerberos client.

```
timed -t
```

To configure the Kerberos KDC and kadmin servers, run the **mkkrb5srv** command. For example, to configure Kerberos for the MYREALM realm, the sundial server, and the xyz.com domain, type the following:

```
mkkrb5srv -r MYREALM -s sundial.xyz.com -d xyz.com -a admin/admin
```

Wait a few minutes for the **kadmind** and **krb5kdc** commands to start from **/etc/inittab**.

Running the **mkkrb5srv** command results in the following actions:

1. Creates the **/etc/krb5/krb5.conf** file. Values for realm name, Kerberos admin server, and domain name are set as specified on the command line. The **/etc/krb5/krb5.conf** file also sets the paths for the **default\_keytab\_name**, **kdc**, and **admin\_server** log files.
2. Creates the **/var/krb5/krb5kdc/kdc.conf** file. The **/var/krb5/krb5kdc/kdc.conf** file sets the values for the **kdc\_ports**, **kadmin\_port**, **max\_life**, **max\_renewable\_life**, **master\_key\_type**, and **supported\_encytypes** variables. This file also sets the paths for the **database\_name**, **admin\_keytab**, **acl\_file**, **dict\_file**, and **key\_stash\_file** variables.
3. Creates the **/var/krb5/krb5kdc/kadm5.acl** file. Sets up the access control for admin, root, and host principals.
4. Creates the database and one admin principal. You are asked to set a Kerberos master key and to name and set the password for a Kerberos administrative principal identity. For disaster-recovery purposes, it is critical that the master key and administrative principal identity and password are securely stored away.

For more information, see “Sample runs” on page 296 and “Error messages and recovery actions” on page 296.

#### *Configuring the Kerberos Version 5 clients:*

After Kerberos installation is complete, it is not apparent to normal users that the Kerberos technology is in use and that they have ticket-granting tickets (TGTs) associated with their running processes. The login process to the operating system remains unchanged, therefore, you must configure the system to use Kerberos as the primary means of user authentication.

To configure systems to use Kerberos as the primary means of user authentication, run the **mkkrb5clnt** command with the following parameters:

```
mkkrb5clnt -c KDC -r realm -a admin -s server -d domain -A -i database -K -T
```

For example, to configure the sundial.xyz.com KDC with the MYREALM realm, sundial.xyz.com admin server, the xyz.com domain, and the files database, type the following:

```
mkkrb5clnt -c sundial.xyz.com -r MYREALM -s sundial.xyz.com -d xyz.com -A -i files -K -T
```

The previous example results in the following actions:

1. Creates the **/etc/krb5/krb5.conf** file. Values for realm name, Kerberos admin server, and domain name are set as specified on the command line. Also, updates the paths for **default\_keytab\_name**, **kdc**, and **kadmin** log files.

2. The **-i** flag configures fully integrated login. The database entered is the location where AIX user identification information is stored. This is different than the Kerberos principal storage. The storage where Kerberos principals are stored is set during the Kerberos configuration.
3. The **-K** flag configures Kerberos as the default authentication scheme. This allows the users to become authenticated with Kerberos at login time.
4. The **-A** flag adds an entry in the Kerberos Database to make root an admin user for Kerberos.
5. The **-T** flag acquires the server admin TGT-based admin ticket.

If a system is installed that is located in a different DNS domain than the KDC, the following additional actions must be performed:

1. Edit the **/etc/krb5/krb5.conf** file and add another entry after [domain realm].
2. Map the different domain to your realm.

For example, if you want to include a client that is in the `abc.xyz.com` domain into your MYREALM realm , the **/etc/krb5/krb5.conf** file includes the following additional entry:

```
[domain realm]
 .abc.xyz.com = MYREALM
```

*Error messages and recovery actions:*

Errors that can occur when using the **mkkrb5srv** command include the following:

- If the **krb5.conf**, **kdc.conf**, or **kadm5.acl** files already exist, the **mkkrb5srv** command does not modify the values. You receive a message that the file already exists. Any of the configuration values can be changed by editing the **krb5.conf**, **kdc.conf**, or **kadm5.acl** files.
- If you mistype something and no database is created, remove the configuration files created and rerun the command.
- If there is inconsistency between the database and configuration values, remove the database from the **/var/krb5/krb5kdc/\*** directory and rerun the command.
- Make sure the **kadmind** and the **krb5kdc** daemons are started on your machine. Use the **ps** command to verify that the daemons are running. If these daemons have not started, check the log file.

Errors that can occur when using the **mkkrb5clnt** command include the following:

- Incorrect values for **krb5.conf** can be fixed by editing the **/etc/krb5/krb5.conf** file.
- Incorrect values for the **-i** flag can be fixed by editing the **/usr/lib/security/methods.cfg** file.

*Files created:*

The **mkkrb5srv** command creates the following files:

- **/etc/krb5/krb5.conf**
- **/var/krb5/krb5kdc/kadm5.acl**
- **/var/krb5/krb5kdc/kdc.conf**

The **mkkrb5clnt** command creates the following file:

- **/etc/krb5/krb5.conf**

The **mkkrb5clnt -i files** option adds the following stanza to the **/usr/lib/security/methods.cfg** file:

```
KRB5:
 program =
 options =
KRB5files:
 options =
```

*Sample runs:*



This section provides examples from sample runs.

The following is an example of the **mkkrb5srv** command:

```
mkkrb5srv -r MYREALM -s sundial.xyz.com -d xyz.com -a admin/admin
```

Output similar to the following displays:

| Fileset                 | Level   | State     | Description                           |
|-------------------------|---------|-----------|---------------------------------------|
| -----                   |         |           |                                       |
| Path: /usr/lib/objrepos |         |           |                                       |
| krb5.server.rte         | 1.3.0.0 | COMMITTED | Network Authentication Service Server |
|                         |         |           |                                       |
| Path: /etc/objrepos     |         |           |                                       |
| krb5.server.rte         | 1.3.0.0 | COMMITTED | Network Authentication Service Server |

```
The -s option is not supported.
The administration server will be the local host.
Initializing configuration...
Creating /etc/krb5/krb5.conf...
Creating /var/krb5/krb5kdc/kdc.conf...
Creating database files...
Initializing database '/var/krb5/krb5kdc/principal' for realm 'MYREALM'
master key name 'K/M@MYREALM'
You will be prompted for the database Master Password.
It is important that you NOT FORGET this password.
Enter database Master Password:
Re-enter database Master Password to verify:
WARNING: no policy specified for admin/admin@MYREALM;
 defaulting to no policy. Note that policy may be overridden by
 ACL restrictions.
Enter password for principal "admin/admin@MYREALM":
Re-enter password for principal "admin/admin@MYREALM":
Principal "admin/admin@MYREALM" created.
Creating keytable...
Creating /var/krb5/krb5kdc/kadm5.acl...
Starting krb5kdc...
krb5kdc was started successfully.
Starting kadmind...
kadmind was started successfully.
The command completed successfully.
Restarting kadmind and krb5kdc
```

The following is an example of the **mkkrb5clnt** command:

```
mkkrb5clnt -r MYREALM -c sundial.xyz.com -s sundial.xyz.com \
-a admin/admin -d xyz.com -ifiles -K -T -A
```

Output similar to the following displays:

```
Initializing configuration...
Creating /etc/krb5/krb5.conf...
The command completed successfully.
Password for admin/admin@MYREALM:
Configuring fully integrated login
Authenticating as principal admin/admin with existing credentials.
WARNING: no policy specified for host/diana.xyz.com@MYREALM;
 defaulting to no policy. Note that policy may be overridden by
 ACL restrictions.
Principal "host/diana.xyz.com@MYREALM" created.

Administration credentials NOT DESTROYED.
Authenticating as principal admin/admin with existing credentials.

Administration credentials NOT DESTROYED.
Authenticating as principal admin/admin with existing credentials.
Principal "kadmind/admin@MYREALM" modified.
```

```
Administration credentials NOT DESTROYED.
Configuring Kerberos as the default authentication scheme
Making root a Kerberos administrator
Authenticating as principal admin/admin with existing credentials.
WARNING: no policy specified for root/diana.xyz.com@MYREALM;
 defaulting to no policy. Note that policy may be overridden by
 ACL restrictions.
Enter password for principal "root/diana.xyz.com@MYREALM":
Re-enter password for principal "root/diana.xyz.com@MYREALM":
Principal "root/diana.xyz.com@MYREALM" created.
```

```
Administration credentials NOT DESTROYED.
Cleaning administrator credentials and exiting.
```

### ***Eliminating the dependency on the kadmind daemon during authentication:***

The KRB5 load module will fail authentication when the **kadmind** daemon is not available. This dependency to the **kadmind** daemon during authentication can be eliminated by setting the **kadmind** options parameter in the **methods.cfg** file.

The possible values are No or False for disabling the **kadmind** lookups and Yes or True for enabling **kadmind** lookups (the default value is Yes). When this option is set to No, the **kadmind** daemon is not contacted during authentication. Therefore, users can log into the system regardless of the status of the **kadmind** daemon (provided that the user enters the correct password when the system prompts one). However, AIX user administration commands such as **mkuser**, **chuser**, or **rmuser** will not work to administrate Kerberos integrated users if the daemon is not available (for example, either the daemon is down or the machine is not accessible).

The default value for the **kadmind** option parameter is Yes. This means that **kadmind** lookups will be performed during authentication. In the default case, if the daemon is not available, the authentication may take longer.

To disable the checking of the **kadmind** daemon during authentication, modify the stanzas in the **methods.cfg** file as follows:

```
KRB5:
 program = /usr/lib/security/KRB5
 options = kadmind=no

KRB5files:
 options = db=BUILTIN,auth=KRB5
```

When the **kadmind** daemon is not available, the root user will not be able to change user passwords. In a situation such as a forgotten password, you must make the **kadmind** daemon available. Also, if a user chooses to enter a Kerberos principal name at the login prompt, the primary name of the principal name will be truncated according to the AIX user name length limitation. This truncated name will be used for AIX user identification information retrieval (for example, to retrieve your home directory value).

If the **kadmind** daemon is not available (the daemon is down or not reachable), the **mkuser** command gives the following error:

```
3004-694 Error adding "krb5user": You do not have permission.
```

Additionally, the **chuser** and **lsuser** commands will manage only AIX related attributes and not Kerberos related attributes. The **rmuser** command will not delete the Kerberos principal and the **passwd** command will fail for Kerberos authenticated users.

If the network where the **kadmind** daemon resides is not accessible, response time will be delayed. Setting the **kadmind** option to No in the **methods.cfg** file eliminates the delays during authentication when the machine is not accessible.

When the **kadmind** daemon is down, users cannot log in if their passwords are expired. Expired passwords need to be changed. Password changes require the availability of the **kadmind** daemon. Consequently, users who require a password change or have expired passwords, will not be able to log in when the **kadmind** daemon is down.

When you set `kadmind=no` but the **kadmind** daemon is running, **lsuser** will fail to retrieve the Kerberos related attributes. However, **login**, **su**, **passwd**, **mkuser**, **chuser**, and **rmuser** commands will succeed.

### ***Installing and configuring the system for Kerberos integrated login using KRB5A:***

When the **KRB5A** load module is used for authentication, a series of steps, such as creation of Kerberos principals, must be performed.

The following section explains how to authenticate an AIX Network Authentication Service client against an Active Directory KDC.

Install the **krb5.client.rte** file set from the Expansion Pack.

**Note:** The KRB5A authentication load module is only supported in AIX 5.2 and later.

*Configuring the AIX Kerberos Version 5 clients with a Windows 2000 active directory server:*

Use the **config.krb5** command to configure an AIX Kerberos client.

Configuring the client requires Kerberos Server information. If a Windows 2000 Active Directory server is chosen as the Kerberos server, the following options can be used with the **config.krb5** command:

```
-r realm = Windows 2000 Active Directory server domain name
-d domain = Domain name of the machine hosting the Windows 2000 Active Directory server
-c KDC = Host name of the Windows 2000 Server
-s server = Host name of the Windows 2000 Server
```

1. Use the **config.krb5** command as shown in the following example:

```
config.krb5 -C -r MYREALM -d xyz.com -c w2k.xyz.com -s w2k.xyz.com
```

2. Windows 2000 supports DES-CBC-MD5 and DES-CBC-CRC encryption types. Change the **krb5.conf** file to contain information similar to the following:

```
[libdefaults]
 default_realm = MYREALM
 default_keytab_name = FILE:/etc/krb5/krb5.keytab
 default_tkt_encypes = des-cbc-crc des-cbc-md5
 default_tgs_encypes = des-cbc-crc des-cbc-md5
```

3. Add the following stanzas in the **methods.cfg** file:

```
KRB5A:
 program = /usr/lib/security/KRB5A
 options = authonly
KRB5Afiles:
 options = db=BUILTLIN,auth=KRB5A
```

4. On a Windows 2000 Active Directory server, do the following:

a. Use the Active Directory Management tool to create a new user account for the *krbtest* AIX host, as follows:

- 1) Select the Users folder.
- 2) Use the mouse to right-click on **New**.
- 3) Choose **user**.
- 4) Type the name *krbtest*.

b. Use the **Ktpass** command from the command line to create a **keytab** file and set up the account for the AIX host. For example, to create a keytab file called **krbtest.keytab**, type:

```
Ktpass -princ host/krbtest.xyz.com@MYREALM -mapuser krbtest -pass password -out krbtest.keytab
```

- c. Copy the keytab file to the AIX host system.
- d. Merge the keytab file into the **/etc/krb5/krb5.keytab** file as follows:
 

```
$ ktutil
ktutil: rkt krbtest.keytab
ktutil: wkt /etc/krb5/krb5.keytab
ktutil: q
```
- e. Create Windows 2000 domain accounts using the Active Directory user-management tools.
- f. Create AIX accounts corresponding to the Windows 2000 domain accounts so that the login process uses Kerberos authentication, as follows:

```
mkuser registry=KRB5Afiles SYSTEM=KRB5Afiles user0
```

## KRB5A authentication load module questions and troubleshooting information

This provides answers to KRB5A authentication load module questions and troubleshooting information.

**Note:** The KRB5A authentication load module is only supported in AIX 5.2 and later.

- ***How do I configure an AIX Kerberos client that authenticates against an active directory server KDC?***

Use the **config.krb5** command to configure an AIX Kerberos client. Configuring the client requires Kerberos Server information. If a Windows 2000 Active Directory server is chosen as the Kerberos server, then use the **config.krb5** command with the following options:

**-r realm**

Active Directory domain name

**-d domain**

Domain name of the machine hosting the Active Directory service

**-c KDC**

The host name of the Windows 2000 server

**-s server**

The host name of the Windows 2000 server

Use the **config.krb5** command as shown in the following example:

```
config.krb5 -C -r MYREALM -d xyz.com -c w2k.xyz.com -s w2k.xyz.com
```

Windows 2000 supports DES-CBC-MD5 and DES-CBC-CRC encryption types. Change the **krb5.conf** file to contain information similar to the following:

```
[libdefaults]
default_realm = MYREALM
default_keytab_name = FILE:/etc/krb5/krb5.keytab
default_tkt_enctypes = des-cbc-crc des-cbc-md5
default_tgs_enctypes = des-cbc-crc des-cbc-md5
```

Add the following stanzas in the **methods.cfg** file:

```
KRB5A:
program = /usr/lib/security/KRB5A
options = authonly
KRB5Afiles:
options = db=BUILTIN,auth=KRB5A
```

On the Active Directory server, do the following:

1. Use the Active Directory Management tool to create a new user account for the *krbtest* AIX host.
  - Select The Users folder.
  - Right-click with the mouse and select New.
  - Choose user.
  - Type the name *krbtest*.

2. Use the **Ktpass** command from the command line to create a **krbtest.keytab** file and set up the account for the AIX host as follows:

```
Ktpass -princ host/krbtest.xyz.com@MYREALM -mapuser krbtest -pass password \
-out krbtest.keytab
```

3. Copy the **krbtest.keytab** file to the AIX host system.
4. Merge the **krbtest.keytab** file into the **/etc/krb5/krb5.keytab** file as follows:

```
$ ktutil
ktutil: rkt krbtest.keytab
ktutil: wkt /etc/krb5/krb5.keytab
ktutil: q
```

5. Create Windows 2000 domain accounts using the Active Directory user management tools.
6. Create AIX accounts corresponding to the Windows 2000 domain accounts such that the login process will know to use Kerberos authentication, as follows:

```
mkuser registry=KRB5Afiles SYSTEM=KRB5Afiles user0
```

- **How do I modify an AIX configuration for Kerberos integrated login?**

To enable Kerberos integrated login, modify the **methods.cfg** file. The compound load-module entry must be added to the **methods.cfg** file. The authentication side is KRB5A. The database side can be chosen as either BUILTIN or LDAP. BUILTIN is the standard AIX user account repository that uses ASCII files. For example, if you choose BUILTIN as the AIX user account repository, then modify the **methods.cfg** file as follows:

Example: Local file system is chosen as the AIX user account repository.

```
KRB5A:
program = /usr/lib/security/KRB5A
options=authonly
```

```
KRB5Afiles:
options = db=BUILTIN,auth=KRB5A
```

Example: LDAP is chosen as the AIX user account repository.

```
KRB5A:
program = /usr/lib/security/KRB5A
options=authonly
```

```
LDAP:
program = /usr/lib/security/LDAP
```

```
KRB5ALDAP:
options = auth=KRB5A,db=LDAP
```

- **How do I create an AIX user for Kerberos integrated login with the KRB5A load module?**

To create an AIX user for Kerberos integrated login with the KRB5A load module, use the **mkuser** command as follows:

```
mkuser registry=KRB5Afiles SYSTEM=KRB5Afiles auth_domain=MYREALM foo
```

- **How do I create Kerberos principals on active directory?**

Creating Windows 2000 user accounts implicitly creates the principals. For example, if you create a user account named **foo** on Active Directory then the principal **foo@MYREALM** associated with the **foo** user is also created. For information on creating users on Active Directory, see the Active Directory user management documentation.

- **How do I change the password of Kerberos authenticated user?**

To change the password of a Kerberos authenticated user, use the **passwd** command, as follows:

```
passwd -R KRB5Afiles foo
```

- **How do I remove a Kerberos authenticated user?**

To remove a Kerberos authenticated user, use the **rmuser** command. However, this only removes the user from AIX. The user must also be removed from Active Directory using the Active Directory user management tools.

```
passwd -R KRB5Afiles foo
```

- **How do I migrate an AIX user to a Kerberos authenticated user?**

If the user already has an account on Active Directory, then the **chuser** command converts the user into an Kerberos authenticated user, as shown in the following example:

```
chuser registry=KRB5Afiles SYSTEM=KRB5Afiles auth_domain=MYREALM foo
```

If the user does not have an account in Active Directory then create an account on Active Directory. Then use the **chuser** command. The Active Directory account may or may not have the same AIX user name. If a different name is chosen, then use the *auth\_name* attribute to map to the Active Directory name. For example, to map the *chris* AIX user name to the *christopher* Active Directory user name, type the following:

```
chuser registry=KRB5Afiles SYSTEM=KRB5Afiles auth_name=christopher auth_domain=MYREALM chris
```

- **What do I do if the password is forgotten?**

On Active Directory, the password must be changed by the administrator. On AIX, the root user cannot set the password of a Kerberos principal.

- **What is the purpose of the *auth\_name* and *auth\_domain* attributes?**

The *auth\_name* and *auth\_domain* attributes are used to map AIX user names into Kerberos principal names on Active Directory. For example, if the AIX user, *chris*, has *auth\_name=christopher* and *auth\_domain=SOMEREA*LM, the Kerberos principal name is *christopher@SOMEREA*LM. The *SOMEREA*LM realm name is not the same as the *MYREALM* default realm name. This allows the *chris* user to authenticate to the *SOMEREA*LM realm instead of to the *MYREALM* realm.

These attributes are optional.

- **Can a Kerberos-authenticated user become authenticated using standard AIX authentication?**

The answer is yes. Perform the following actions to authenticate the Kerberos-authenticated user using AIX authentication:

1. The user sets the AIX password (*/etc/security/passwd*) using the **passwd** command, as follows:

```
passwd -R files foo
```

2. Change the *SYSTEM* attribute of the user, as follows:

```
chuser -R KRB5Afiles SYSTEM=compat foo.
```

This changes the authentication from Kerberos to crypt.

If you want to use crypt authentication as a backup mechanism, the *SYSTEM* attribute is changed as follows:

```
chuser -R KRB5Afiles SYSTEM="KRB5Afiles or compat" foo.
```

- **Do I need to set up Kerberos server on AIX when using a Windows 2000 active directory server?**

No, because users are authenticating against an Active Directory KDC, there is no need to configure the KDC on AIX. If you want to use AIX Network Authentication Services KDC as the Kerberos server instead, then the Kerberos server must be configured.

- **What do I do if AIX does not accept my password?**

Check that the password meets the requirements of both AIX and Kerberos. KDC must also be configured and running correctly.

- **What do I do if I cannot log into the system?**

If you cannot log into the system, do the following:

- Verify that the KDC is up and running.

- On AIX systems, type the following:

```
ps -ef | grep krb5kdc
```

- On Windows 2000 systems, do the following:

1. In the Control Panel, double-click the Administrative Tools icon
  2. Double-click the Services icon.
  3. Verify that the Kerberos Key Distribution Center is in the Started state.
- On AIX systems, verify that the **/etc/krb5/krb5.conf** file points to the correct KDC, and has valid parameters.
  - On AIX systems, verify that client **keytab** file contains the host ticket. For example, assume you have the **/etc/krb5/krb5.keytab** default **keytab** file. Type the following:

```
$ ktutil
ktutil: rkt /etc/krb5/krb5.keytab
ktutil: l

slot KVNO Principal

 1 4 host/krbtest.xyz.com@MYREALM

ktutil: q
```

- Verify that, if the *auth\_name* and *auth\_domain* attributes are set, they refer to a valid principal name on the ADS KDC.
  - Verify that the *SYSTEM* attribute is set for Kerberos login (KRB5Afiles or KRB5ALDAP).
  - Verify that password is not expired.
- **How can I disable TGT verification?**

The host/**Host\_Name** principal is used to verify a TGT. The keys for this host principal are stored in the Kerberos default **keytab** file and the **keytab** file needs to be securely transferred from the Windows 2000 Active Directory server to the client machine as explained in the Security Guide. The TGT verification could be disabled by specifying an option in the **/usr/lib/security/methods.cfg** file under the KRB5A stanza as follows:

```
KRB5A:
 program = /usr/lib/security/KRB5A
 options = tgt_verify=no
KRB5Afiles:
 options = db=BUILTIN,auth=KRB5A
```

The possible values for **tgt\_verify** are No or False for disabling, and Yes or True for enabling. By default, the TGT verification is enabled. When **tgt\_verify** is set to No, TGT verification is not performed and there is no need to transfer the keys of the host principal. This eliminates the need for the **keytab** file for authentication purposes when KRB5A module is used.

## Kerberos module

The Kerberos module is a kernel extension used by the NFS client and server code. It allows the NFS client and server code to process Kerberos message integrity and privacy functions without making calls to the **gss** daemon.

The Kerberos module is loaded by the **gss** daemon. The methods used are based on Network Authentication Service version 1.2, which is, in turn, based on MIT Kerberos.

The location of the Kerberos module is: **/usr/lib/drivers/krb5.ext**.

For related information, see the **gss** daemon.

## Remote authentication dial-in user service server

IBM's Remote Authentication Dial-In User Service (RADIUS) is a network access protocol designed to do authentication, authorization, and accounting. It is a port-based protocol that defines the communications between Network Access Servers (NAS) and authentication and accounting servers.

A NAS operates as a client of RADIUS. Transactions between the client and the RADIUS server are authenticated through the use of a *shared secret*, which is not sent over the network. Any user passwords sent between the client and the RADIUS server are encrypted.

The client is responsible for passing user information to designated RADIUS servers and then acting on the response that is returned. RADIUS servers are responsible for receiving user connection requests, authenticating the user, and then returning all configuration information necessary for the client to deliver service to the user. A RADIUS server can act as a proxy client to other RADIUS servers when advanced proxy information is configured. RADIUS uses User Datagram Protocol (**UDP**) as the transport protocol.

## Installing the RADIUS server

You can install the RADIUS server using either the **installp** command or SMIT. The RADIUS software is on the AIX base media, and the image names are `radius.base` and `bos.msg.<lang>.rte`.

If you plan to use the LDAP directory as your information database to store user names and passwords, you must install the `ldap.server`. The **installp** software must be installed on each RADIUS server installation.

The RADIUS daemons can be started using the SRC master commands. When started, there will be multiple **radiusd** processes running:

- One process for authorization
- One process for accounting
- One process is a monitor process for the other daemons

Upon reboot, the daemons are automatically started at run level 2. To change this routine, modify the `/etc/rc.d/rc2.d/Sradiusd` file.

## Stopping and restarting RADIUS

You must stop and restart the **radiusd** daemons whenever changes are made to the RADIUS server's `/etc/radius/radiusd.conf` configuration file, or to the default authorization files, `/etc/radius/authorization/default.policy` or `/etc/radius/authorization/default.auth`. This can be handled from SMIT or from a command line.

To stop and restart the RADIUS server, use the following commands:

```
>stopsrc -s radiusd
>startsrc -s radiusd
```

Stopping and starting RADIUS is necessary because the daemon must build a memory table of all default attributes contained in the above configuration files. Shared memory is used for each local user and the local user table only gets built at daemon initialization time for performance reasons.

### ***On-demand feature:***

You can start multiple RADIUS authentication and accounting server daemons as needed.

Each server listens on a separate port. The **radiusd.conf** file is shipped with a default port number of 1812 for authentication and 1813 for accounting. These are IANA assigned port numbers. By updating **radiusd.conf**, these port numbers, along with other ports (multiples) as needed, can be used. Be sure to use port numbers that are not assigned to existing services. When multiple port numbers are entered in the **Authentication\_Ports** and **Accounting\_Ports** fields in the **radiusd.conf** file, a **radiusd** daemon is started for each port. The daemons will listen on their respective port number.

## RADIUS configuration files

The RADIUS daemon uses several configuration files. Sample versions of these files are shipped in the RADIUS package.



All configuration files are owned by the root user and the security group. You can edit all of the configuration files, except the dictionary file, with the System Management Interface Tool (SMIT). The server must be restarted before any modifications to the configuration files will take effect.

**radiusd.conf file:**

The **radiusd.conf** file contains the configuration parameters for RADIUS.

By default, RADIUS searches for the **radiusd.conf** file in the **/etc/radius** directory. Configuration file entries must be in the formats as shown in the file. RADIUS accepts only valid keywords and values, and uses the default if a valid keyword or value is not used. When you launch the RADIUS daemons, check the SYSLOG output for configuration parameter errors. Not all configuration errors lead to the server stopping.

This file should be appropriately read-protected and write-protected because it affects the behavior of authentication and accounting servers. Also, confidential data might exist in the file.

**Important:** If you edit the **radiusd.conf** file, do not change the order of the entries. SMIT panels rely on the order.

The following is an example of the **radiusd.conf** file:

```
#-----#
CONFIGURATION FILE
#
By default RADIUS will search for radiusd.conf in the
/etc/radius directory.
#
Configuration file entries need to be in the below
formats. RADIUS will accept only valid "Keyword : value(s)",
and will use defaults, if "Keyword : value(s)" are not
present or are in error.
#
It is important to check the syslog output when launching
the radius daemons to check for configuration parameter
errors. Once again, not all configuration errors will lead to
the server stopping.
#
Lastly, this file should be appropriately read/write protected,
because it will affect the behavior of authentication and
accounting, and confidential or secretive material may
exist in this file.
#
IF YOU ARE EDITING THIS FILE, DO NOT CHANGE THE ORDER OF THE
ENTRIES IN THIS FILE. SMIT PANELS DEPEND ON THE ORDER.
#
#
#-----#

#-----#
Global Configuration
#
RADIUSdirectory : This is the base directory for the RADIUS
daemon. The daemon will search this
directory for further configuration files.
#
Database_location : This is the value of where the
authentication (user ids & passwords)
will be stored and retrieved.
Valid values: Local, LDAP, UNIX
UNIX - User defined in AIX system
Local - Local AVL Database using raddbm
LDAP - Central Database
#
#-----#
```

```

Local_Database : This indicates the name of the local
database file to be used.
This field must be completed if the
Database location is Local.
#
Debug_Level : This pair sets the debug level at which
the RADIUS server will run. Appropriate
values are 0,3 or 9. The default is 3.
Output is directed to location specified
by *.debug stanza in /etc/syslog.conf
#
Each level increases the amount of messages
sent to syslog. For example "9" includes
the new messages provided by "9" as well
as all messages generated by level 0 and 3.
#
0 : provides the minimal output to the
syslogd log. It sends start up
and end messages for each RADIUS
process. It also logs error
conditions.
#
3 : includes general ACCESS ACCEPT, REJECT
and DISCARD messages for each packet.
This level provides a general audit
trail for authentication.
#
9 : Maximum amount of log data. Specific
values of attributes while a
transaction is passing thru
processing and more.
[NOT advised under normal operations]
#
#-----#
RADIUSdirectory : /etc/radius
Database_location : UNIX
Local_Database : dbdata.bin
Debug_Level : 3
#-----#
Accounting Configuration
#
Local_Accounting : When this flag is set to ON or TRUE a file
will contain a record of ACCOUNTING START
and STOP packets received from the Network
Access Server(NAS). The default log file
is:
/var/radius/data/accounting
#
Local_accounting_loc : /var/radius/data/accounting
path and file name of the local
accounting data file. Used only if Local_
Accounting=ON. If the default is
changed, then the path and file need to
to be created (with proper permissions)
by the admin.
#
#-----#
Local_Accounting : ON
Local_Accounting_loc : /var/radius/data/accounting
#-----#
Reply Message Attributes
#
Accept_Reply-Message : Sent when the RADIUS server
replies with an Access-Accept packet
#
Reject_Reply-Message : Sent when the RADIUS server
replies with an Access-Reject packet

```

```

#
Challenge_Reply-Message : Sent when the RADIUS server
replies with an Access-Challenge
packet
#-----#
Accept_Reply-Message :
Reject_Reply-Message :
Challenge_Reply-Message :
Password_Expired_Reply-Message :
#-----#
Support Renewal of Expired Password
#
Allow_Password_Renewal: YES or NO
Setting this attribute to YES allows
users to update their expired password
via the RADIUS protocol. This requires
the hardware support of
Access-Password-Request packets.
#-----#
Allow_Password_Renewal : NO
#-----#
Require Message Authenticator in Access-Request
#
Require_Message_Authenticator: YES or NO
Setting this attribute to YES
checks message authenticator
in Access-Request packet.If not
present, it will discard the
packet.
#-----#
Require_Message_Authenticator : NO
#-----#
Servers (Authentication and Accounting)
#
Authentication_Ports : This field indicates on which port(s)
the authentication server(s) will listen
on. If the field is blank an
authentication daemon will not be
started.
The value field may contain more than
one value. Each value is REQUIRED to
be separated by a comma ','.
#
The value field must contain a numeric
value, like "6666". In this case a
server daemon will listen on "6666".
#
Accounting_Ports : The same as authentication_Ports. See
above definitions.
#
[NOTE] There is no check for port conflicts. If a server is
currently running on the specified port the daemon will
error and not run. Be sure to check the syslog output
insure that all servers have started without incident.
#
[Example]
Authentication_Ports : 1812,6666 (No Space between commas)
#
In the above example a sever will be start for each port
specified. In the case
#
6666 : port 6666
#-----#
Authentication_Ports : 1812
Accounting_Ports : 1813

```

```

#-----#
LDAP Directory User Information
#
Required if RADIUS is to connect to a LDAP Version 3 Directory
and the Database_location field=LDAP
#
LDAP_User : User ID which has admin permission to connect
to the remote (LDAP) database. This is the
the LDAP administrator's DN.
#
LDAP_User_Pwd : Password associated with the above User Id
which is required to authenticate to the LDAP
directory.
#
#-----#
LDAP_User : cn=root
LDAP_User_Pwd :
#-----#
LDAP Directory Information
#
If the Database_location field is set to "LDAP" then the
following fields need to be completed.
#
LDAP_Server_name : This field specifies the fully qualified
host name where the LDAP Version 3
Server is located.
LDAP_Server_Port : The TCP port number for the LDAP server
The standard LDAP port is 389.
LDP_Base_DN : The distinguished name for search start
LDAP_Timeout : # seconds to wait for a response from
the LDAP server
LDAP_Hoplimit : maximum number of referrals to follow
in a sequence
LDAP_Sizelimit : size limit (in entries) for search
LDAP_Debug_level : 0=OFF 1=Trace ON
#
#-----#
LDAP_Server_name :
LDAP_Server_port : 389
LDAP_Base_DN : cn=aixradius
LDAP_Timeout : 10
LDAP_Hoplimit : 0
LDAP_Sizelimit : 0
LDAP_Debug_level : 0
#-----#
PROXY RADIUS Information
#
#
Proxy_Allow : ON or OFF. If ON, then the server
can proxy packets to realms it
knows of and the following
fields must also be configured.
Proxy_Use_Table : ON or OFF. If ON, then the server
can use table for faster
processing of duplicate requests
Can be used without proxy ON, but
it is required to be ON if
Proxy_Use_Table is set to ON.
Proxy_Realm_name : This field specifies the realm
this server services.
Proxy_Prefix_delim : A list of separators for parsing
realm names added as a prefix to
the username. This list must be
mutually exclusive to the Suffix
delimiters.
Proxy_Suffix_delim : A list of separators for parsing
realm names added as a suffix to

```

```

the username. This list must be
mutually exclusive to the Prefix
delimiters.
Proxy_Remove_Hops : YES or NO. If YES then the
will remove its realm name, the
realm names of any previous hops
and the realm name of the next
server the packet will proxy to.
#
Proxy_Retry_count : The number of times to attempt
to send the request packet.
#
Proxy_Time_Out : The number of seconds to wait
in between send attempts.
#
#-----#
Proxy_Allow : OFF
Proxy_Use_Table : OFF
Proxy_Realm_name :
Proxy_Prefix_delim : $/
Proxy_Suffix_delim : @.
Proxy_Remove_Hops : NO
Proxy_Retry_count : 2
Proxy_Time_Out : 30
#-----#
Local Operating System Authentication Configuration
#
UNIX_Check_Login_Restrictions : ON or OFF. If ON, during
local operating system authen-
tication, a call to
loginrestrictions() will be
made to verify the user has
no local login restrictions.
#
#-----#
UNIX_Check_Login_Restrictions : OFF
#-----#
Global IP Pooling Flag
#
Enable_IP_Pool : ON or OFF. If ON, then RADIUS Server will do
IP address assignment from a pool of addresses
defined to the RADIUS server.
#
#-----#
Enable_IP_Pool : OFF
#-----#

```

### **/etc/radius/clients file:**

The **clients** file contains a list of clients that are allowed to make requests of the RADIUS server.

Typically, for each client, NAS or AP, you must enter the client IP address along with the shared secret between the RADIUS server and the client and an optional *poolname* for IP pooling.

The file consists of entries in the following form:

```
<Client IP Address> <Shared Secret> <Pool Name>
```

A sample entry list appears as follows:

```
10.10.10.1 mysecret1 floor6
10.10.10.2 mysecret2 floor5
```

A shared secret is a character string that is configured on both the client hardware and on the RADIUS server. The maximum length of the shared secret is 256 bytes and is case sensitive. The shared secret is

not sent in any of the RADIUS packets and is never sent over the network. System administrators must make sure the exact secret is configured on both sides (client and RADIUS server). The shared secret is used for encrypting the user password information and can be used for verifying message integrity by the use of a Message Authentication attribute.

Each client's shared secret should be unique in the `/etc/radius/clients` file and, like any good password, it is best to use a mixture of uppercase/lowercase letters, numbers, and symbols in the secret. To keep a shared secret secure, make it at least 16 characters in length. The `/etc/radius/clients` file can be modified using SMIT. The shared secret should be changed often to prevent dictionary attacks.

The `poolname` is the name of the pool from which global IP addresses are allocated during dynamic translation. The system administrator creates the `poolname` when setting up the RADIUS server. Using a SMIT panel, the `poolname` is added from **Configure Proxy Rules** → **IP Pool** → **Create an IP Pool**. It is used during server side IP pooling.

### **`/etc/radius/dictionary file:`**

The **dictionary** file contains descriptions of the attributes that are defined by the RADIUS protocol and supported by the AIX RADIUS Server.

It is used by the RADIUS daemon when validating and creating packet data. Vendor-specific attributes should also be added here. The dictionary file can be modified using any editor. There is no SMIT interface.

The following is part of a sample dictionary file:

```
#####
#
This file contains dictionary translations for parsing
requests and generating responses. All transactions are
composed of Attribute/Value Pairs. The value of each attribute
is specified as one of 4 data types. Valid data types are:
#
string - 0-253 octets
ipaddr - 4 octets in network byte order
integer - 32 bit value in big endian order (high byte first)
date - 32 bit value in big endian order - seconds since
00:00:00 GMT, Jan. 1, 1970
#
Enumerated values are stored in the user file with dictionary
VALUE translations for easy administration.
#
Example:
#
ATTRIBUTE VALUE

Framed-Protocol = PPP
7 = 1 (integer encoding)
#
#####
ATTRIBUTE User-Name 1 string
ATTRIBUTE User-Password 2 string
ATTRIBUTE CHAP-Password 3 string
ATTRIBUTE NAS-IP-Address 4 ipaddr
ATTRIBUTE NAS-Port 5 integer
ATTRIBUTE Service-Type 6 integer
ATTRIBUTE Framed-Protocol 7 integer
ATTRIBUTE Framed-IP-Address 8 ipaddr
ATTRIBUTE Framed-IP-Netmask 9 ipaddr
ATTRIBUTE Framed-Routing 10 integer
```

```

ATTRIBUTE Filter-Id 11 string
.
.
.

```

**Note:** Any attribute that is defined in the **default.policy** file or the **default.auth** file (or for a specific **user\_id.policy** or **user\_id.auth** file), must be a valid RADIUS attribute as defined in the local AIX dictionary configuration file. If an attribute is not found in the dictionary, the **radiusd** daemon does not load and an error message is logged.

**Note:** If the dictionary, the **default.policy** file and the **default.auth** file, for the system is modified, you must restart the RADIUS daemons by running the **stopsrc** command and the **startsrc** command or by using SMIT.

***/etc/radius/proxy file:***

The **/etc/radius/proxy** file is a configuration file that supports the proxy feature. This file maps known realms that the proxy server can forward packets to.

The **/etc/radius/proxy** file uses the IP address of the server that handles packets for that realm and the shared secret between the two servers.

The file contains the following fields that you can modify with SMIT:

- **Realm Name**
- **Next Hop IP address**
- **Shared Secret**

The following is an example of a **/etc/radius/proxy** file:

**Note:**

The shared secret should be 16 characters in length. The same shared secret must be configured on the RADIUS server next hop.

```

@(#)91 1.3 src/rad/usr/sbin/config_files/proxy, radconfig, radius530 1/23/04 13:11:14
#####
#
This file contains a list of proxy realms which are
authorized to send/receive proxy requests/responses to/from
this RADIUS server and their Shared secret used in encryption.
#
The first field is the name of the realm of the remote RADIUS
Server.
#
The second field is a valid IP address for the remote RADIUS
Server.
#
The third column is the shared secret associated with this
realm.
#
NOTE: This file contains sensitive security information and
precautions should be taken to secure access to this
file.
#
#####
REALM NAME REALM IP SHARED SECRET
#-----
myRealm 10.10.10.10 sharedsec

```

## Authentication

Traditional authentication uses a name and a fixed password and generally takes place when the user first logs in to a machine or requests a service. RADIUS relies on an authentication database to store user IDs, passwords, and other information.

For user authentication, the server can use a local database, UNIX passwords or LDAP. Database location is configured in the server's **/etc/radius/radiusd.conf** file during setup, or by updating the file through SMIT. See "RADIUS configuration files" on page 304 for more information on RADIUS configuration files.

### **User databases:**

The RADIUS software can use different databases to store user information.

You can use a local, UNIX, or LDAP database to store user information.

#### *UNIX:*

The UNIX authentication option allows RADIUS to use the local system authentication method to authenticate the user.

To use local UNIX authentication, edit the **radiusd.conf** file's **database\_location** field, or select UNIX in SMIT's Database Location field. This authentication method calls the UNIX **authenticate()** application program interface (API) to authenticate a user ID and password. Passwords are saved in the same data file that UNIX uses, such as **/etc/passwords**. User IDs and passwords are created using the **mkuser** command or through SMIT.

To use the UNIX database, select UNIX in the **Database Location** field as shown below:

```
Configure Server
RADIUS Directory /etc/radius
*Database Location [UNIX]
Local AVL Database File Name [dbdata.bin]
Local Accounting [ON]

Debug Level [3]
.
.
.
```

#### *Local:*

If either the **radiusd.conf** file's **database\_location** field or SMIT's Database Location entry contains the word **Local**, then the RADIUS Server will use **/etc/radius/dbdata.bin** as the location for all of the user IDs and passwords.

The local user database is flat file that contains the user ID and password information. Passwords are saved in a hashed format. Hashing is a fast addressing technique for directly accessing data in the memory space. To add, delete, or modify user passwords, run the **raddbm** command or use SMIT. When the **radiusd** daemon starts, it reads the **radiusd.conf** file and loads the user IDs and passwords into memory.

**Note:** The maximum user ID length is 253 characters and the maximum password length is 128 characters.

To use the local user database, select **Local** in the **Database Location** field as shown below:



```

Configure Server

RADIUS Directory /etc/radius
*Database Location [Local]
Local AVL Database File Name [dbdata.bin]
Local Accounting [ON]

Debug Level [3]
.
.
.

```

**LDAP:**

RADIUS can use LDAP Version 3 to store remote user data.

RADIUS will use LDAP Version 3 API calls to access user data remotely. LDAP Version 3 access occurs if the **database\_location** field in the **/etc/radiusd.conf** file is set to LDAP and the server name, the LDAP administrator user ID, and LDAP administrator password are configured.

AIX uses the LDAP Version 3 client libraries that are supported and packaged in the IBM Tivoli Directory Server. LDAP is a scalable protocol and the benefit of using LDAP is that user and in-process data can be located in a centralized location, easing administration of the RADIUS server. You can use the command line utility, **ldapsearch**, to view any of the RADIUS data.

Also, LDAP must be configured and administered before it can be used for RADIUS. Read the IBM Tivoli Directory Server publications at <http://publib.boulder.ibm.com/tividd/td/IBMDirectoryServer5.2.html> to learn more about setting up the LDAP server.

The RADIUS server provides LDAP **ldif** files to add the RADIUS schema, including object classes and attributes, to a directory, but you must set up and configure LDAP.

A separate suffix is created specifically for RADIUS to use the RADIUS LDAP objects. This suffix is a container with the name **cn=aixradius**, and it contains two object classes as described in “RADIUS LDAP server configuration” on page 314. You apply a RADIUS-supplied **ldif** file that creates the suffix and RADIUS schema.

When you use LDAP as the authentication database you get the following features:

1. A user database that can be seen and accessed from all RADIUS servers
2. A list of active users
3. The feature of allowing a maximum number of logins per user ID
4. An **EAP** type that can be configured per user
5. A password expiration date.

To use the LDAP database, select LDAP in the **Database Location** field as shown below:

```

Configure Server

RADIUS Directory /etc/radius
*Database Location [LDAP]
Local AVL Database File Name [dbdata.bin]
Local Accounting [ON]

Debug Level [3]
.
.
.

```

### *RADIUS LDAP server configuration:*

When LDAP user authentication is configured, the LDAP server schema must be updated. The LDAP system administrator must add AIX RADIUS defined attributes and objectclasses to the LDAP directory before defining LDAP RADIUS users.

You must add a suffix to the LDAP server. The suffix for RADIUS is named `cn=aixradius`. A suffix is a distinguished name that identifies the top entry in a directory hierarchy.

When a suffix is added, the LDAP directory has an empty container. A *container* is an empty entry that can be used to partition the namespace. A container is similar to a file system directory, where it can have directory entries beneath it. User profile information can then be added to the LDAP directory through SMIT. The LDAP administrator ID and password are stored in the `/etc/radius/radiusd.conf` file and can be configured through SMIT on a RADIUS server.

To organize the information stored in LDAP directory entries, the schema defines object classes. An object class consists of a set of required and optional attributes. Attributes are in the form of `type=value` pairs, in which the type is defined by a unique object identifier (OID) and the value has a defined syntax. Every entry in the LDAP directory is an instance of an object.

**Note:** The object class, by itself, does not define a directory information tree or namespace. This only occurs when entries are created and the specific instance of object classes are given unique distinguished names. For example, when a container object class is given a unique DN, it can then be associated with two other entries which are instances of the object class organizational unit. The result is a tree-like structure or namespace.

Object classes are specific to the RADIUS server and are applied from an `ldif` file. Some of the attributes are existing LDAP schema attributes and some are specific to RADIUS. The new RADIUS object classes are structural and abstract.

For security purposes, the binds to the LDAP server use the simple bind or SASL API call, `ldap_bind_s` which will include the DN and, CRAM-MD5 as the authentication method, and the LDAP administrator password. This will transmit message digests rather than the password themselves over the network. CRAM-MD5 is a security mechanism where there is not special configuration necessary on either side (client or server).

**Note:** All of the attributes in the object classes are single-value.

### *RADIUS LDAP namespace:*

The RADIUS LDAP namespace has the `cn=aixradius` container as the top of its hierarchy. Below `cn=aixradius`, there are two organizational units (OUs). These OUs are containers that help make the entries unique.

The following figure graphically depicts the RADIUS LDAP schema. This figure shows containers and organizational units all represented by circles and connected by lines or branches. The `aixradius` container, in the center, branches down to two organizational units: `ibm-radiususer` and `ibm-radiusactiveusers`. Below the `ibm-radiususer` container are implied `userid`, `password` and `maxLogin` containers. Below the `ibm-radiusactiveusers` container are implied `userid +`, `login number`, `login status` and `session_id` containers. Above the `aixradius` container is the `aixsecurity` container and the root container is at the top.

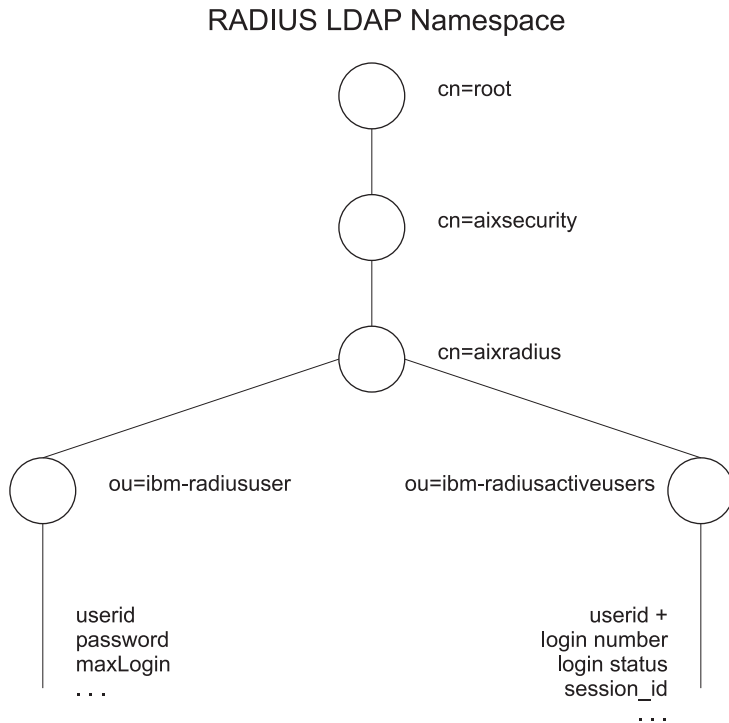

Figure 19. RADIUS LDAP Namespace

LDAP namespace schema files:

The LDAP schema files define object classes and RADIUS-specific attributes for the LDAP namespace.

The following LDAP schema files are located in the `/etc/radius/ldap` directory:

#### **IBM.V3.radiusbase.schema.ldif**

This file defines top level object class for the RADIUS server (`cn=aixradius`). The file also creates the following branches under the `cn=aixradius` object class:

```
ou=ibm-radiususer
ou=ibm-radiusactiveusers
```

You can add the required information by using the following command:

```
ldapadd -D ldap_admin_id -w password -i /etc/radius/ldap/IBM.V3.radiusbase.schema.ldif
```

You can run this command on the LDAP server system, or you can run it remotely with the `-h` (host system name) option.

#### **IBM.V3.radius.schema.ldif**

This file defines the RADIUS-specific attributes and object classes.

You can add the new RADIUS attributes and object classes by typing the following command:

```
ldapmodify -D ldap_admin_id -w password -i /etc/radius/ldap/IBM.V3.radius.schema.ldif
```

You must also specify LDAP as the database location through SMIT and enter the LDAP server name and administrator password. After you do this, you can add RADIUS LDAP users to the directory through SMIT.

*User profile object class:*

LDAP user profiles must be entered into the system before the RADIUS server can authenticate a user to the system. Profiles contain the user ID and password.

User profile objects provide the data about the specific individuals that have access to the network and contain authentication information. The **ibm-radiusUserInstance** object class is accessed synchronously with the LDAP API calls from the daemon. The unique field, which is the start of the DN is the user ID. The **MaxLoginCount** field limits the number of times the LDAP user can log in.

*Active login list object class:*

The LDAP active login list represents the data that contains information about the users currently logged in.

There are multiple records per user with a starting record of `login_number = 1`, up to the `MaxLoginCount` number of 5. The session ID is taken from the RADIUS `start_accounting` message. The partially completed records are created when an **ibm-radiusUserInstance** object is created. This means that most of the fields are empty before RADIUS accounting packets are received. After a RADIUS `start_accounting` message is received, the **ibm-radiusactiveusers** object updates to specify that the user is now currently logged in, and the unique session information is written to the correct login number. After the `stop_accounting` message is received, the information in the active login list record is cleared. The active login record is updated to reflect that the user is now logged off. The session numbers in the start and stop accounting messages are the same unique number. The object class will be accessed synchronously in the LDAP API calls.

#### ***Password authentication protocol:***

Password Authentication Protocol (**PAP**) provides security by coding the user's password with an MD5 hash algorithm of a value that both the client and server can construct.

It works as follows:

1. In packets that have the user password, the Authentication field contains a 16 octet random number called the Request Authenticator.
2. The Request Authenticator and the client's shared secret are put into an MD5 hash. The result is a 16 octet hash.
3. The user-provided password is padded to 16 octets with nulls.
4. The hash from step 2 is XORed (Exclusive-OR) with the padded password. This is the data sent in the packet as the *user\_password* attribute.
5. The RADIUS server calculates the same hash as that in Step 2.
6. This hash is XORed with the packet data from Step 4, thus recovering the password.

#### ***Challenge handshake authentication protocol:***

RADIUS also supports the use of the PPP's **CHAP** for password protection.

With CHAP, the user's password is not sent across the network. Instead, an MD5 hash of the password is sent, and the RADIUS server reconstructs the hash from the user's information, including the stored password, then compares this with the value sent by the client.

#### ***Extensible authentication protocol:***

The Extensible Authentication Protocol (**EAP**) is a protocol designed to support multiple authentication methods.

**EAP** specifies the structure of an authentication communication between a client and an authentication server, without defining the content of the authentication data. This content is defined by the specific **EAP** method that is used for authentication. Common **EAP** methods include:

- MD5-challenge
- One-time password
- Generic token card
- Transport layer security (TLS)

RADIUS takes advantage of **EAP** by specifying RADIUS attributes that are used to transfer **EAP** data between the RADIUS server and its clients. This **EAP** data can then be sent by the RADIUS server directly to back-end servers that implement the various **EAP** authentication methods.

The AIX RADIUS server supports only the MD5-challenge **EAP** method. The **EAP** method used to authenticate a user is set, at the user level, by setting a value in the user's entry in either the local database or LDAP. By default, **EAP** is turned off for each user.

## Authorization

RADIUS allows authorization attributes per user as defined in the authorization policy files, **default.auth** and **default.policy**.

Authorization attributes are valid RADIUS protocol attributes that are specified in the RFC and defined in the **/etc/radius/dictionary** file. Authorization is optional and depends on how the hardware NAS or access point is configured. You must configure authorization attributes if they are needed. Authorization only happens after a successful authentication occurs.

Policies are configurable user attribute-value pairs that can control how the user accesses the network. Policies can be defined as being global to the RADIUS server, or user-specific.

Two authorization configuration files are shipped: **/etc/radius/authorization/default.auth** and **default.policy**. The **default.policy** file is used to match the incoming access request packets. The file contains attribute-value pairs that are initially blank and must be configured to the desired settings. After authentication, the policy will determine if an access accept or access reject packet is returned to the client.

Each user can also have a **user\_id.policy** file. If a user has a unique policy file created for their specific user ID, then that file's attributes are checked first. If the attribute-value pairs in the **user\_id.policy** file do not exactly match, then the **default.policy** file is checked. If the attribute pairs from the access request packet do not match in either file, then an access reject packet is sent. If a match is found in one or the other file, an access accept packet is sent to the client. This effectively establishes two levels of policy.

The **default.auth** file is used as the list of attribute-value pairs to return to the client once the policy has been checked. The **default.auth** file also contains attribute-value pairs that are initially blank and must be configured to the desired settings. You must edit the **default.auth** file or use SMIT to configure the desired authorization attribute settings. Each attribute that contains a value will automatically be returned to the NAS in an access accept packet.

You can also define user-specific return authorization attributes by creating a file based on the unique user name with the **.auth** extension, such as **user\_id.auth**. This custom file must reside in the **/etc/radius/authorization** directory. There is a SMIT panel that allows you create and edit each user file.

Each user's authorization attributes are sent back in an access accept packet along with any default authorization attributes found in the **default.auth** file. If the values are common in the **default.auth** file and the **user\_id.auth** file, then the user's values override the default values. This allows for some global authorization attributes (services or resources) to all users and then for more specific, per user, level of authorization.

The authorization process is as follows:

1. At daemon startup time, the default policy and authorization lists from the **/etc/radius/authorization/default.policy** file and the **default.auth** file are read into memory.
2. Authenticate the user ID and password.
3. The incoming packet is checked for attribute-value pairs.
  - a. Check the custom **user\_id.auth** file.
  - b. If no match is found, then check the **default.policy** file.
  - c. If no match is found, then send an access reject packet.
4. Apply the user's authorization attributes if there are any.
  - a. Read the **/etc/radius/authorization/user\_id.auth** file and the **default.auth** file, and compare the two entries.
  - b. Use the entry that is in the user's file above the global entry.
5. Return the authorization attributes in an access accept packet.

## Accounting

The RADIUS accounting server is responsible for receiving accounting requests from a client and returning responses to the client indicating that it has successfully received the request and written the accounting data.

You can enable local accounting in the **radiusd.conf** file.

When a client is configured to use RADIUS accounting, it will generate an ACCOUNTING\_START packet describing the type of service being delivered and the user to whom it is being delivered at the start of service delivery. The client will send the packet to the RADIUS accounting server, which returns an acknowledgment that the packet has been received. At the end of service delivery, the client generates an ACCOUNTING\_STOP packet describing the type of service that was delivered and, optionally, statistics such as elapsed time, input and output octets, or input and output packet numbers. When the ACCOUNTING\_STOP packet is received by the RADIUS accounting server, it returns an acknowledgment to the accounting client that the packet has been received.

The ACCOUNTING\_REQUEST, whether for START or STOP, is submitted to the RADIUS accounting server via the network. It is recommended that the client continue attempting to send the ACCOUNTING\_REQUEST packet until it receives an acknowledgment. The client can also forward requests to an alternate server or servers in the event that the primary server is down or unreachable through the use of proxy configuration. For more information on proxy services, see "Proxy services" on page 319.

Accounting data is written in standard RADIUS format of *attribute=value* to the local **/etc/var/radius/data/accounting** file. The data written is the accounting data in the packet, with a time stamp. If the RADIUS accounting server is unable to successfully record the accounting packet, it will not send an **Accounting\_Response** acknowledgment to the client and error information will be logged to the **syslog** file.

### **/var/radius/data/accounting file:**

The **/var/radius/data/accounting** captures what the client sends in the ACCOUNTING START and ACCOUNTING STOP packets.

The **/var/radius/data/accounting** file is empty when first installed. Data is written to the file based on what the client sends in the ACCOUNTING START and ACCOUNTING STOP packets.

The following is a sample of the type of data the AIX RADIUS server writes to the **/var/radius/data/accounting** file. Your information will differ depending on how your system is set up.

**Note:**

- Be sure the **/var** filesystem is large enough to handle all the accounting data.
- Third-party Perl scripts can be used to parse the data in this file. Examples of scripts that generate reports from the accounting data can be found at <http://www.pgregg.com/projects/radiusreport>
- The accounting packets can also be proxied.

```
Thu May 27 14:43:19 2004
NAS-IP-Address = 10.10.10.1
NAS-Port = 1
NAS-Port-Type = Async
User-Name = "rod"
Acct-Status-Type = Start
Acct-Authentic = RADIUS
Service-Type = Framed-User
Acct-Session-Id = "0000000C"
Framed-Protocol = PPP
Acct-Delay-Time = 0
Timestamp = 1085686999
```

```
Thu May 27 14:45:19 2004
NAS-IP-Address = 10.10.10.1
NAS-Port = 1 <-- rod was physically connected to port #1 on the hardware
NAS-Port-Type = Async
User-Name = "rod"
Acct-Status-Type = Stop
Acct-Authentic = RADIUS
Service-Type = Framed-User
Acct-Session-Id = "0000000C" <-- note the session id's are the same so can match up start with stops
Framed-Protocol = PPP
Framed-IP-Address = 10.10.10.2 <-- IP address of user rod
Acct-Terminate-Cause = User-Request <-- user cancelled the session
Acct-Input-Octets = 4016
Acct-Output-Octets = 142
Acct-Input-Packets = 35
Acct-Output-Packets = 7
Acct-Session-Time = 120 <--- seconds
Acct-Delay-Time = 0
Timestamp = 1085687119 <--- note "rod" was only logged on for 120 seconds (2 minutes)
```

**Proxy services**

Proxy services allow the RADIUS server to forward requests from a NAS to another RADIUS server and then return a reply message to the NAS. Proxy services are based on a realm name.

The RADIUS server can act as both a proxy server and a back-end server simultaneously. This mechanism is applicable for both accounting and authentication packets. Proxy is disabled by default in the **radiusd.conf** file.

**Realms:**

Realms are identifiers that are placed before or after the values normally contained in the User-Name attribute that a RADIUS server can use to identify the server to contact to start the authentication and accounting process.

The following example illustrates how realms are used with RADIUS:

User, *Joe*, is employed by company XYZ in Sacramento. The realm for this area is *SAC*. However, *Joe* is currently in New York City on a remote assignment. The realm for New York City is *NYC*. When *Joe* dials into the *NYC* realm, the User-Name passed is *SAC/Joe*. This notifies the *NYC* RADIUS realm server that this packet needs to be forwarded to the server that does the authenticating and accounting for *SAC* realm users.

### *Realm user-name attribute:*

Authentication and accounting packets are routed through the realm is based on the **User-Name** attribute. This attribute defines the order of realms the packet goes through in order to route it to the final server that does the authentication or accounting.

Packets are routed by stringing realms together in the **User-Name** attribute. The actual realms that are inserted into the **User-Name** attribute, which ultimately determines the path of the packet, is a decision left up to the administrator deploying the RADIUS layout. It is possible to put the names of the realm hops in front of the **User-Name** attribute, as well as behind it. The most popular characters to delineate the different realms are the slash (/) as the prefix delineator in front of the **User-Name** attribute, and ampersand (&) as the suffix delineator behind the **User-Name** attribute. Delineators are configured in the **radiusd.conf** file. The **User-Name** attribute is parsed from left to right.

An example of a **User-Name** attribute using only the prefix method is the following:

```
USA/TEXAS/AUSTIN/joe
```

An example of a **User-Name** attribute using only the suffix method is the following:

```
joe@USA@TEXAS@AUSTIN
```

It is possible to use both prefix and suffix methods. It is important to remember when specifying the realm hops a packet will go through that the order of hops is parsed left to right, and all prefix hops are processed before processing suffix hops. The user must be authenticated, or the accounting data written, at a single node.

The following example, using both methods, yields the same result as the previous examples:

```
USA/joe@TEXAS@AUSTIN
```

### **Configuring proxy services:**

RADIUS proxy configuration information is located in the **proxy** file in the **/etc/radius** directory.

The initial **proxy** file contains example entries. There are three fields in the proxy file: **Realm Name**, **Next Hop IP address**, and **Shared Secret**.

To configure proxy rules, select from the following::

Configure Proxy Rules

List all Proxy  
Add a Proxy  
Change / Show Characteristics of a Proxy  
Remove a Proxy

Select the **List all Proxy** option to read the **/etc/radius/proxy** file and display the three fields in column format. The following are the column headers:

```
realm_name next_hop_address shared_secret
```

Select **Add a Proxy** to display the following screen. Information is retrieved from the panel and the data is appended to the bottom of the **/etc/radius/proxy** file.

Each hop of the proxy chain uses the shared secret between the two RADIUS servers. The shared secret is contained in the **/etc/radius/proxy\_file**. The shared secret should be unique per proxy hop in the chain.

For more information about creating shared secrets, see "**/etc/radius/clients** file" on page 309.



To add a proxy, select from the fields as shown below:

```

 Add a Proxy
*Realm Name [] (max 64 chars)
*Next Hop IP address (dotted decimal) [xx.xx.xx.xx]
*Shared Secret [] (minimum 6, maximum 256 chars)
```

Selecting the **Change/Show** option displays a list of the realm names. The list is displayed in a pop-up screen and you must select a realm name.

The **Remove a Proxy** option displays a list of the realm names. The list is displayed in a pop-up screen and the user must select a realm name. After a name is selected, a verification pop-up screen is displayed before the realm is removed.

The following example is the proxy configuration information section of a **radiusd.conf** file:

```
#-----#
PROXY RADIUS Information
#
Proxy_Allow : ON or OFF. If ON, then the server
can proxy packets to realms it
knows of and the following
fields must also be configured.
Proxy_Use_Table : ON or OFF. If ON, then the server
can use table for faster
processing of duplicate requests
Can be used without proxy ON, but
it is required to be ON if
Proxy_Use_Table is set to ON.
Proxy_Realm_name : This field specifies the realm
this server services.
Proxy_Prefix_delim : A list of separators for parsing
realm names added as a prefix to
the username. This list must be
mutually exclusive to the Suffix
delimiters.
Proxy_Suffix_delim : A list of separators for parsing
realm names added as a suffix to
the username. This list must be
mutually exclusive to the Prefix
delimiters.
Proxy_Remove_Hops : YES or NO. If YES then the
will remove its realm name, the
realm names of any previous hops
and the realm name of the next
server the packet will proxy to.
#
Proxy_Retry_count : The number of times to attempt
to send the request packet.
#
Proxy_Time_Out : The number of seconds to wait
in between send attempts.
#
#-----#
Proxy_Allow : OFF
Proxy_Use_Table : OFF
Proxy_Realm_name :
Proxy_Prefix_delim : $/
Proxy_Suffix_delim : @.
Proxy_Remove_Hops : NO
Proxy_Retry_count : 2
Proxy_Time_Out : 3
```

**Configuring the RADIUS server:**

The RADIUS server daemon uses several configuration files. Server configuration information is saved in the `/etc/radius/radiusd.conf` file. The packaged server configuration file is shipped with default values.

**Note:**

The following is a sample RADIUS Configure Server SMIT panel:

```
Configure Server

RADIUS Directory /etc/radius
*Database Location [UNIX]
Local AVL Database File Name [dbdata.bin]
Local Accounting [ON]
Local Accounting Directory []

Debug Level [3]
Accept Reply-Message []
Reject Reply-Message []
Challenge Reply-Message []
Password Expired Reply Message []
Support Renewal of Expired Passwords [NO]
Require Message Authenticator [NO]

*Authentication Port Number [1812]
*Accounting Port Number [1813]

LDAP Server Name []
LDAP Server Port Number [389]
LDAP Server Admin Distinguished Name []
LDAP Server Admin Password []
LDAP Base Distinguished Name [cn=aixradius]
LDAP Size Limit [0]
LDAP Hop Limit [0]
LDAP wait time limit [10]
LDAP debug level [0]

Proxy Allowed [OFF]
Proxy Use table [OFF]
Proxy Realm Name []
Proxy Prefix Delimiters [$/]
Proxy Suffix Delimiters [@.]
NOTE: prefix & suffix are mutually exclusive
Proxy Remove Hops [NO]
Proxy Retry Count [2]
Proxy Timeout [30]
UNIX Check Login Restrictions [OFF]
Enable IP Pool [ON]
```

## Logging utilities

The RADIUS server uses SYSLOG to log activity and error information.

There are three levels of log information:

- 0        Only problems or errors and the starting of daemons are logged.
- 3        Logs an audit trail of access\_accept, access\_reject\*, discard, and error messages.  
**Note:** discard messages are logged when an incoming packet is invalid and a response packet is not generated.
- 9        Includes 0 and 3 level logging information and much more. Only run level 9 logging to debug.

The default level of logging is level 3. Logging at level 3 is used to improve the level of auditing of the RADIUS server. Depending on what level the server is logging, you can use the activities stored in the log to check for suspicious patterns of activity. If security is violated, the SYSLOG output can be used to determine how and when the violation occurred and perhaps the amount of access gained. This information is useful in the development of better security measures to prevent future problems.

For information on LDAP logging, see the IBM Tivoli Directory Server Version 5.2 Administration Guide in the Tivoli Software Information Center.

### **Configuring RADIUS to use the syslogd daemon:**

In order to use SYSLOG to view activity and error information, you must enable the syslogd daemon.

To enable the syslogd daemon, complete the following steps.

1. Edit the **/etc/syslog.conf** file to add the following entry: `local4.debug var/adm/ipsec.log`. Use the *local4* facility to record traffic and IP Security events. Standard operating system priority levels apply. You should set the priority level of *debug* until traffic through IP Security tunnels and filters show stability and proper movement.

**Note:** The logging of filter events can create significant activity at the IP Security host and can consume large amounts of storage.

2. Save the **/etc/syslog.conf** file.
3. Go to the directory you specified for the log file and create an empty file with the same name. In the case above, you would change to **/var/adm** directory and run the **touch** command as follows:

```
touch ipsec.log
```

4. Run the **refresh** command to the **syslogd** subsystem as follows:

```
refresh -s syslogd
```

### **Configuring SYSLOG output settings:**

You can set a `Debug_Level` of 0, 3, or 9 is set in the **radiusd.conf** file, depending on how much debugging information you want included in the SYSLOG output.

The default setting is 3. The debug section of the **radiusd.conf** file looks similar to the following:

```
#.
#.
#.
Debug_Level : This pair sets the debug level at which
the RADIUS server will run. Appropriate
values are 0,3 or 9. The default is 3.
Output is directed to location specified
by *.debug stanza in /etc/syslog.conf
#
Each level increases the amount of messages#
sent to syslog. For example "9" includes
the new messages provided by "9" as well
as all messages generated by level 0 and 3.#
#
0 : provides the minimal output to the
syslogd log. It sends start up
and end messages for each RADIUS
process. It also logs error
conditions.
#
3 : includes general ACCESS ACCEPT, REJECT
and DISCARD messages for each packet.
This level provides a general audit
trail for authentication.
#
9 : Maximum amount of log data. Specific
values of attributes while a
transaction is passing thru
processing and more.
[NOT advised under normal operations]
#
#-----#
```

The following examples show sample output for various debug levels.

### Accounting packet with debug level 3

```
Aug 18 10:23:57 server1 syslog: [0]:Monitor process [389288] has started
Aug 18 10:23:57 server1 radiusd[389288]: [0]:Local database (AVL) built.
Aug 18 10:23:57 server1 radiusd[389288]: [0]:Authentication process started : Pid= 549082 Port = 1812
Aug 18 10:23:57 server1 radiusd[389288]: [0]:Accounting process started : Pid= 643188 Port = 1813
Aug 18 10:23:57 server1 radiusd[643188]: [0]:Socket created [15]
Aug 18 10:23:57 server1 radiusd[643188]: [0]:Bound Accounting socket [15]
Aug 18 10:23:57 server1 radiusd[549082]: [0]:Socket created [15]
Aug 18 10:23:57 server1 radiusd[549082]: [0]:Bound Authentication socket [15]
Aug 18 10:24:07 server1 radiusd[643188]: [1]:*** Start Process_Packet() ***
Aug 18 10:24:07 server1 radiusd[643188]: [1]:Code 4, ID = 96, Port = 41639 Host = 10.10.10.10
Aug 18 10:24:07 server1 radiusd[643188]: [1]:ACCOUNTING-START - sending Accounting Ack to User [user_id1]
Aug 18 10:24:07 server1 radiusd[643188]: [1]:Sending Accounting Ack of id 96 to 10.10.10.10 (client1.ibm.com)
Aug 18 10:24:07 server1 radiusd[643188]: [1]:send_acct_reply() Outgoing Packet:
Aug 18 10:24:07 server1 radiusd[643188]: [1]: Code = 5, Id = 96, Length = 20
Aug 18 10:24:07 server1 radiusd[643188]: [1]:*** Leave Process_Packet() ***
Aug 18 10:24:13 server1 radiusd[643188]: [2]:*** Start Process_Packet() ***
Aug 18 10:24:13 server1 radiusd[643188]: [2]:Code 4, ID = 97, Port = 41639 Host = 10.10.10.10
Aug 18 10:24:13 server1 radiusd[643188]: [2]:ACCOUNTING-STOP - sending Accounting Ack to User [user_id1]
Aug 18 10:24:14 server1 radiusd[643188]: [2]:Sending Accounting Ack of id 97 to 10.10.10.10 (client1.ibm.com)
Aug 18 10:24:14 server1 radiusd[643188]: [2]:send_acct_reply() Outgoing Packet:
Aug 18 10:24:14 server1 radiusd[643188]: [2]: Code = 5, Id = 97, Length = 20
Aug 18 10:24:14 server1 radiusd[643188]: [2]:*** Leave Process_Packet() **
```

### Accounting packets at level 9

```
Aug 18 10:21:18 server1 syslog: [0]:Monitor process [643170] has started
Aug 18 10:21:18 server1 radiusd[643170]: [0]:Local database (AVL) built.
Aug 18 10:21:18 server1 radiusd[643170]: [0]:Authentication process started : Pid= 389284 Port = 1812
Aug 18 10:21:18 server1 radiusd[643170]: [0]:Accounting process started : Pid= 549078 Port = 1813
Aug 18 10:22:03 server1 radiusd[643170]: [0]:PID = [389284] dead
Aug 18 10:22:03 server1 radiusd[643170]: [0]:PID = [549078] dead
Aug 18 10:22:03 server1 radiusd[643170]: [0]:All child processes stopped. radiusd parent stopping
Aug 18 10:22:09 server1 syslog: [0]:Monitor process [1081472] has started
Aug 18 10:22:09 server1 radiusd[1081472]: [0]:Local database (AVL) built.
Aug 18 10:22:09 server1 radiusd[1081472]: [0]:Inside client_init()
Aug 18 10:22:09 server1 radiusd[1081472]: [0]:Number of client entries read: 1
Aug 18 10:22:09 server1 radiusd[1081472]: [0]:Inside read_authorize_policy routine for file:
/etc/radius/authorization/default.policy.
Aug 18 10:22:09 server1 radiusd[1081472]: [0]:Inside read_authorize_file routine for file:
/etc/radius/authorization/default.policy.
Aug 18 10:22:09 server1 radiusd[1081472]: [0]:read_authorize_file() routine complete.
Aug 18 10:22:09 server1 radiusd[1081472]: [0]:Inside read_authorize_file routine for file:
/etc/radius/authorization/default.auth.
Aug 18 10:22:09 server1 radiusd[1081472]: [0]:read_authorize_file() routine complete.
Aug 18 10:22:09 server1 radiusd[549080]: [0]:connect_to_LDAP_server:Database Location (where the data
resides)=LDAP.
Aug 18 10:22:09 server1 radiusd[549080]: [0]:connect_to_LDAP_server:LDAP Server name= server1.austin.ibm.com.
Aug 18 10:22:09 server1 radiusd[549080]: [0]:connect_to_LDAP_server:LDAP Server port= 389.
Aug 18 10:22:09 server1 radiusd[1081472]: [0]:Authentication process started : Pid= 549080 Port = 1812
Aug 18 10:22:09 server1 radiusd[389286]: [0]:connect_to_LDAP_server:Database Location (where the data
resides)=LDAP.
Aug 18 10:22:09 server1 radiusd[389286]: [0]:connect_to_LDAP_server:LDAP Server name= server1.austin.ibm.com.
Aug 18 10:22:09 server1 radiusd[389286]: [0]:connect_to_LDAP_server:LDAP Server port= 389.
Aug 18 10:22:09 server1 radiusd[1081472]: [0]:Accounting process started : Pid= 389286 Port = 1813
Aug 18 10:22:10 server1 radiusd[549080]: [0]:Socket created [15]
Aug 18 10:22:10 server1 radiusd[549080]: [0]:Bound Authentication socket [15]
Aug 18 10:22:10 server1 radiusd[389286]: [0]:Socket created [15]
Aug 18 10:22:10 server1 radiusd[389286]: [0]:Bound Accounting socket [15]
Aug 18 10:22:15 server1 radiusd[389286]: [1]:*** Start Process_Packet() ***
Aug 18 10:22:15 server1 radiusd[389286]: [1]:Incoming Packet:
Aug 18 10:22:15 server1 radiusd[389286]: [1]: Code = 4, Id = 94, Length = 80
Aug 18 10:22:15 server1 radiusd[389286]: [1]: Authenticator = 0xC5DBDDFE6EFFFDBD6AE64CA35947DD0F
Aug 18 10:22:15 server1 radiusd[389286]: [1]: Type = 40, Length = 6, Value = 0x00000001
Aug 18 10:22:15 server1 radiusd[389286]: [1]: Type = 1, Length = 8, Value = 0x67656E747931
Aug 18 10:22:15 server1 radiusd[389286]: [1]: Type = 4, Length = 6, Value = 0x00000000
Aug 18 10:22:15 server1 radiusd[389286]: [1]: Type = 8, Length = 6, Value = 0x0A0A0A01
Aug 18 10:22:15 server1 radiusd[389286]: [1]: Type = 44, Length = 8, Value = 0x303030303062
Aug 18 10:22:15 server1 radiusd[389286]: [1]: Type = 30, Length = 10, Value = 0x3132332D34353638
```

```
Aug 18 10:22:15 server1 radiusd[389286]: [1]: Type = 31, Length = 10, Value = 0x3435362D31323335
Aug 18 10:22:15 server1 radiusd[389286]: [1]: Type = 85, Length = 6, Value = 0x00000259
Aug 18 10:22:15 server1 radiusd[389286]: [1]:Starting parse_packet()
Aug 18 10:22:15 server1 radiusd[389286]: [1]:Code 4, ID = 94, Port = 41639 Host = 10.10.10.10
Aug 18 10:22:15 server1 radiusd[389286]: [1]:Acct-Status-Type = Sta
```

### Level 0 authentication packet

```
Aug 18 10:06:11 server1 syslog: [0]:Monitor process [1081460] has started
Aug 18 10:06:11 server1 radiusd[1081460]: [0]:Local database (AVL) built.
Aug 18 10:06:11 server1 radiusd[1081460]: [0]:Authentication process started : Pid= 549076 Port = 1812
Aug 18 10:06:11 server1 radiusd[1081460]: [0]:Accounting process started : Pid= 389282 Port = 18
```

### Level 3 authentication packet

```
Aug 18 10:01:32 server2 radiusd[389276]: [3]:*** Start Process_Packet() ***
Aug 18 10:01:32 server2 radiusd[389276]: [3]:Code 1, ID = 72, Port = 41638 Host = 10.10.10.10
Aug 18 10:01:32 server2 radiusd[389276]: [3]:authenticate_password_PAP: Passwords do not match, user is rejected
Aug 18 10:01:32 server2 radiusd[389276]: [3]:Authentication failed for user [user_id1] using IP [10.10.10.10]
Aug 18 10:01:32 server2 radiusd[389276]: [3]:ACCESS-REJECT - sending reject for id 72 to 10.10.10.10
(client1.ibm.com)
Aug 18 10:01:32 server2 radiusd[389276]: [3]:send_reject() Outgoing Packet:
Aug 18 10:01:32 server2 radiusd[389276]: [3]: Code = 3, Id = 72, Length = 30
Aug 18 10:01:32 server2 radiusd[389276]: [3]:*** Leave Process_Packet() ***
Aug 18 10:01:53 server2 radiusd[389276]: [4]:*** Start Process_Packet() ***
Aug 18 10:01:53 server2 radiusd[389276]: [4]:Code 1, ID = 74, Port = 41638 Host = 10.10.10.10
Aug 18 10:01:53 server2 radiusd[389276]: [4]:authenticate_password_PAP: Passwords Match, user is authenticated
Aug 18 10:01:53 server2 radiusd[389276]: [4]:Authentication successful for user [user_id1] using IP [10.10.10.10]
Aug 18 10:01:53 server2 radiusd[389276]: [4]:Authorization successful for user [user_id1] using IP [10.10.10.10]
Aug 18 10:01:53 server2 radiusd[389276]: [4]:ACCESS-ACCEPT - sending accept for id 74 to 10.10.10.10
(client1.ibm.com)
Aug 18 10:01:53 server2 radiusd[389276]: [4]:send_accept() Outgoing Packet:
Aug 18 10:01:53 server2 radiusd[389276]: [4]: Code = 2, Id = 74, Length = 31
Aug 18 10:01:53 server2 radiusd[389276]: [4]:*** Leave Process_Packet() **
```

### Level 9 authentication packet

```
Aug 18 10:03:56 server1 radiusd[389278]: [1]:*** Start Process_Packet() ***
Aug 18 10:03:56 server1 radiusd[389278]: [1]:Incoming Packet:
Aug 18 10:03:56 server1 radiusd[389278]: [1]: Code = 1, Id = 77, Length = 58
Aug 18 10:03:56 server1 radiusd[389278]: [1]: Authenticator = 0xE6CB0F9C22BB4E799854E734104FB2D5
Aug 18 10:03:56 server1 radiusd[389278]: [1]: Type = 1, Length = 8, Value = 0x67656E747931
Aug 18 10:03:56 server1 radiusd[389278]: [1]: Type = 4, Length = 6, Value = 0x00000000
Aug 18 10:03:56 server1 radiusd[389278]: [1]: Type = 2, Length = 18, Value = 0x*****

Aug 18 10:03:56 server1 radiusd[389278]: [1]: Type = 7, Length = 6, Value = 0x00000001
Aug 18 10:03:56 server1 radiusd[389278]: [1]:Starting parse_packet()
Aug 18 10:03:56 server1 radiusd[389278]: [1]:Code 1, ID = 77, Port = 41638 Host = 10.10.10.10
Aug 18 10:03:56 server1 radiusd[389278]: [1]:User-Name = "user_id1"
Aug 18 10:03:56 server1 radiusd[389278]: [1]:NAS-IP-Address = 10.10.10.10
Aug 18 10:03:56 server1 radiusd[389278]: [1]:Framed-Protocol = PPP
Aug 18 10:03:56 server1 radiusd[389278]: [1]:Leaving parse_packet()
Aug 18 10:03:56 server1 radiusd[389278]: [1]:Verifying Message-Authenticator
Aug 18 10:03:56 server1 radiusd[389278]: [1]:Message-Authenticator successfully verified
Aug 18 10:03:56 server1 radiusd[389278]: [1]:Inside proxy_request_needed() function
Aug 18 10:03:56 server1 radiusd[389278]: [1]:Proxy is not turned on
Aug 18 10:03:56 server1 radiusd[389278]: [1]:Username = [user_id1]
Aug 18 10:03:56 server1 radiusd[389278]: [1]:Client IP = [10.10.10.10]
Aug 18 10:03:56 server1 radiusd[389278]: [1]:Inside parse_for_login(user_id1)
Aug 18 10:03:56 server1 radiusd[389278]: [1]:User_id remaining after prefix removal = [user_id1]
Aug 18 10:03:56 server1 radiusd[389278]: [1]:User_id remaining after suffix removal = [user_id1]
Aug 18 10:03:56 server1 radiusd[389278]: [1]:Inside rad_authenticate() function
Aug 18 10:03:56 server1 radiusd[389278]: [1]:Authentication request received for [client1.austin.ibm.com]
Aug 18 10:03:56 server1 radiusd[389278]: [1]:Calling get_ldap_user() to get LDAP user data
Aug 18 10:03:56 server1 radiusd[389278]: [1]:get_ldap_user:LDAP user id: user_id1.
Aug 18 10:03:56 server1 radiusd[389278]: [1]:get_ldap_user:LDAP max_login_cnt:2.
Aug 18 10:03:56 server1 radiusd[389278]: [1]:get_ldap_user:LDAP EAP_type: 4.
Aug 18 10:03:56 server1 radiusd[389278]: [1]:get_ldap_user:LDAP passwordexpiredweeks: 9.
Aug 18 10:03:56 server1 radiusd[389278]: [1]:get_ldap_active_sessions:number of free entries= 2.
Aug 18 10:03:56 server1 radiusd[389278]: [1]:get_ldap_active_session:dn retrieved=
radiusuniqueidentifier=user_id11,ou=radiusActiveUsers,cn=aixradius.
Aug 18 10:03:56 server1 radiusd[389278]: [1]:Inside get_client_secret routine for ip:10.10.10.10
```

```

Aug 18 10:03:56 server1 radiusd[389278]: [1]:Found NAS-IP = [10.10.10.10]
Aug 18 10:03:56 server1 radiusd[389278]: [1]:Found shared secret.
Aug 18 10:03:56 server1 radiusd[389278]: [1]:authenticate_password_PAP: Passwords Match, user is authenticated
Aug 18 10:03:56 server1 radiusd[389278]: [1]:is_ldap_pw:password for user has NOT expired
Aug 18 10:03:56 server1 radiusd[389278]: [1]:Authentication successful for user [user_id1] using IP [10.10.10.10]
Aug 18 10:03:56 server1 radiusd[389278]: [1]:Inside rad_authorize() routine.
Aug 18 10:03:56 server1 radiusd[389278]: [1]:Inside read_authorize_policy routine for file:
/etc/radius/authorization/user_id1.policy.
Aug 18 10:03:56 server1 radiusd[389278]: [1]:Inside read_authorize_file routine for file:
/etc/radius/authorization/user_id1.policy.
Aug 18 10:03:56 server1 radiusd[389278]: [1]:Did not open /etc/radius/authorization/user_id1.policy file.
File may not be found.
Aug 18 10:03:56 server1 radiusd[389278]: [1]:Error reading policy file: /etc/radius/authorization/user_id1.policy.
Aug 18 10:03:56 server1 radiusd[389278]: [1]:rad_authorize:default policy list and userpolicy list were empty.
Aug 18 10:03:56 server1 radiusd[389278]: [1]:In create_def_copy() routine.
Aug 18 10:03:56 server1 radiusd[389278]: [1]:Successfully made a copy of the master authorization list.
Aug 18 10:03:56 server1 radiusd[389278]: [1]:Inside read_authorize_file routine for file:
/etc/radius/authorization/user_id1.auth.
Aug 18 10:03:56 server1 radiusd[389278]: [1]:Did not open /etc/radius/authorization/user_id1.auth file.
File may not be found.
Aug 18 10:03:56 server1 radiusd[389278]: [1]:rad_authorize:copy authorization list and user list were empty.
Aug 18 10:03:56 server1 radiusd[389278]: [1]:Authorization successful for user [user_id1] using IP [10.10.10.10]
Aug 18 10:03:56 server1 radiusd[389278]: [1]:ACCESS-ACCEPT - sending accept for id 77 to 10.10.10.10
(client1.austin.ibm.com)
Aug 18 10:03:56 server1 radiusd[389278]: [1]:Inside proxy_response_needed() function
Aug 18 10:03:56 server1 radiusd[389278]: [1]:Proxy is not turned on
Aug 18 10:03:56 server1 radiusd[389278]: [1]:Inside get_client_secret routine for ip:10.10.10.10
Aug 18 10:03:56 server1 radiusd[389278]: [1]:Found NAS-IP = [10.10.10.10]
Aug 18 10:03:56 server1 radiusd[389278]: [1]:Found shared secret.
Aug 18 10:03:56 server1 radiusd[389278]: [1]:send_accept() Outgoing Packet:
Aug 18 10:03:56 server1 radiusd[389278]: [1]: Code = 2, Id = 77, Length = 31
Aug 18 10:03:56 server1 radiusd[389278]: [1]:send_accept() Outgoing Packet:
Aug 18 10:03:56 server1 radiusd[389278]: [1]: Code = 2, Id = 77, Length = 31
Aug 18 10:03:56 server1 radiusd[389278]: [1]: Authenticator = 0xCCB2B645BBEE86F5E4FC5BE24E904B2A
Aug 18 10:03:56 server1 radiusd[389278]: [1]: Type = 18, Length = 11, Value = 0x476F6F646E65737321
Aug 18 10:03:56 server1 radiusd[389278]: [1]:*** Leave Process_Packet() ***
Aug 18 10:04:18 server1 radiusd[389278]: [2]:*** Start Process_Packet() ***
Aug 18 10:04:18 server1 radiusd[389278]: [2]:Incoming Packet:
Aug 18 10:04:18 server1 radiusd[389278]: [2]: Code = 1, Id = 79, Length = 58
Aug 18 10:04:18 server1 radiusd[389278]: [2]: Authenticator = 0x774298A2B6DD90D7C33B3C10C4787D41
Aug 18 10:04:18 server1 radiusd[389278]: [2]: Type = 1, Length = 8, Value = 0x67656E747931
Aug 18 10:04:18 server1 radiusd[389278]: [2]: Type = 4, Length = 6, Value = 0x00000000
Aug 18 10:04:18 server1 radiusd[389278]: [2]: Type = 2, Length = 18, Value = 0x*****

Aug 18 10:04:18 server1 radiusd[389278]: [2]: Type = 7, Length = 6, Value = 0x00000001
Aug 18 10:04:18 server1 radiusd[389278]: [2]:Starting parse_packet()
Aug 18 10:04:18 server1 radiusd[389278]: [2]:Code 1, ID = 79, Port = 41638 Host = 10.10.10.10
Aug 18 10:04:18 server1 radiusd[389278]: [2]:User-Name = "user_id1"
Aug 18 10:04:18 server1 radiusd[389278]: [2]:NAS-IP-Address = 10.10.10.10
Aug 18 10:04:18 server1 radiusd[389278]: [2]:Framed-Protocol = PPP
Aug 18 10:04:18 server1 radiusd[389278]: [2]:Leaving parse_packet()
Aug 18 10:04:18 server1 radiusd[389278]: [2]:Verifying Message-Authenticator
Aug 18 10:04:18 server1 radiusd[389278]: [2]:Message-Authenticator successfully verified
Aug 18 10:04:18 server1 radiusd[389278]: [2]:Inside proxy_request_needed() function
Aug 18 10:04:18 server1 radiusd[389278]: [2]:Proxy is not turned on
Aug 18 10:04:18 server1 radiusd[389278]: [2]:Username = [user_id1]
Aug 18 10:04:18 server1 radiusd[389278]: [2]:Client IP = [10.10.10.10]
Aug 18 10:04:18 server1 radiusd[389278]: [2]:Inside parse_for_login(user_id1)
Aug 18 10:04:18 server1 radiusd[389278]: [2]:User_id remaining after prefix removal = [user_id1]
Aug 18 10:04:18 server1 radiusd[389278]: [2]:User_id remaining after suffix removal = [user_id1]
Aug 18 10:04:18 server1 radiusd[389278]: [2]:Inside rad_authenticate() function
Aug 18 10:04:18 server1 radiusd[389278]: [2]:Authentication request received for [client1.austin.ibm.com]
Aug 18 10:04:18 server1 radiusd[389278]: [2]:Calling get_ldap_user() to get LDAP user data
Aug 18 10:04:18 server1 radiusd[389278]: [2]:get_ldap_user:LDAP user id: user_id1.
Aug 18 10:04:18 server1 radiusd[389278]: [2]:get_ldap_user:LDAP max_login_cnt:2.
Aug 18 10:04:18 server1 radiusd[389278]: [2]:get_ldap_user:LDAP EAP_type: 4.
Aug 18 10:04:18 server1 radiusd[389278]: [2]:get_ldap_user:LDAP passwordexpiredweeks: 9.
Aug 18 10:04:18 server1 radiusd[389278]: [2]:get_ldap_active_sessions:number of free entries= 2.
Aug 18 10:04:18 server1 radiusd[389278]: [2]:get_ldap_active_session:dn retrieved=
radiusuniqueidentifier=user_id11, ou=radiusActiveUsers, cn=aixradius.
Aug 18 10:04:18 server1 radiusd[389278]: [2]:Inside get_client_secret routine for ip:10.10.10.10
Aug 18 10:04:18 server1 radiusd[389278]: [2]:Found NAS-IP = [10.10.10.10]

```

```

Aug 18 10:04:18 server1 radiusd[389278]: [2]:Found shared secret.
Aug 18 10:04:18 server1 radiusd[389278]: [2]:authenticate_password_PAP: Passwords do not match, user is rejected
Aug 18 10:04:18 server1 radiusd[389278]: [2]:Authentication failed for user [user_id1] using IP [10.10.10.10]
Aug 18 10:04:18 server1 radiusd[389278]: [2]:ACCESS-REJECT - sending reject for id 79 to 10.10.10.10
(client1.austin.ibm.com)
Aug 18 10:04:18 server1 radiusd[389278]: [2]:Inside proxy_response_needed() function
Aug 18 10:04:18 server1 radiusd[389278]: [2]:Proxy is not turned on
Aug 18 10:04:18 server1 radiusd[389278]: [2]:Inside get_client_secret routine for ip:10.10.10.10
Aug 18 10:04:18 server1 radiusd[389278]: [2]:Found NAS-IP = [10.10.10.10]
Aug 18 10:04:18 server1 radiusd[389278]: [2]:Found shared secret.
Aug 18 10:04:18 server1 radiusd[389278]: [2]:send_reject() Outgoing Packet:
Aug 18 10:04:18 server1 radiusd[389278]: [2]: Code = 3, Id = 79, Length = 30
Aug 18 10:04:18 server1 radiusd[389278]: [2]:send_reject() Outgoing Packet:
Aug 18 10:04:18 server1 radiusd[389278]: [2]: Code = 3, Id = 79, Length = 30
Aug 18 10:04:18 server1 radiusd[389278]: [2]: Authenticator = 0x05D4865C6EBEFC1A9300D2DC66F3DBE9
Aug 18 10:04:18 server1 radiusd[389278]: [2]: Type = 18, Length = 10, Value = 0x4261646E65737321
Aug 18 10:04:18 server1 radiusd[389278]: [2]:*** Leave Process_Packet() **

```

## Password expiration

Password expiration allows the RADIUS client to be notified when a user's password has expired, and to update the user's password through the RADIUS protocol.

Password expiration involves supporting four more packet types and a new attribute. The new packet types are shipped in the AIX dictionary and the password expiration feature must be turned on.

It may not be desirable in every RADIUS installation to allow expired password updating through RADIUS. An entry in the **radiusd.conf** file gives you the option to allow or disallow support for expired password changing through RADIUS. The default for this option is to disallow. You can add a `Password_Expired_Reply_Message` user reply message and this is returned in the password-expired packet. Password attributes, both old and new, must be encrypted and decrypted with the PAP method.

## Vendor-specific attributes

Vendor-specific attributes (VSA) are defined by remote-access server vendors, usually hardware vendors, to customize how RADIUS works on their servers.

The vendor-specific attributes are necessary if you want to give users permission for more than one type of access. The VSAs may be used in combination with RADIUS-defined attributes.

VSAs are optional, but if the NAS hardware requires additional attributes to be configured in order to function properly, you must add the VSAs to the dictionary file.

VSAs can also be used for further authorization. Along with **User-Name** and **Password**, you can use VSAs for authorization. On the server side, the user authorization policy file contains the list of attributes to be checked in the Access-Request packet for a particular user. If the packet does not contain the attributes listed in the users file, then an `access_reject` is sent back to NAS. VSAs can also be used as an `attribute=value` pair list in the **user\_id.policy** file.

The following is a sample VSA section taken from the dictionary:

```

#####
#
This section contains examples of dictionary translations for
parsing vendor specific attributes (vsa). The example below is for
"Cisco." Before defining an Attribute/Value pair for a
vendor a "VENDOR" definition is needed.
#
Example:
#
VENDOR Cisco 9
#
VENDOR: This specifies that the Attributes after this entry are
specific to Cisco.
#
Cisco : Denotes the Vendor name
#

```

```

9 : Vendor Id defined in the "Assigned Numbers" RFC
#
#####
#VENDOR Cisco 9
#ATTRIBUTE Cisco-AVPair 1 string
#ATTRIBUTE Cisco-NAS-Port 2 string
#ATTRIBUTE Cisco-Disconnect-Cause 195 integer
#
#-----Cisco-Disconnect-Cause-----#
#
#VALUE Cisco-Disconnect-Cause Unknown 2
#VALUE Cisco-Disconnect-Cause CLID-Authentication-Failure 4
#VALUE Cisco-Disconnect-Cause No-Carrier 10
#VALUE Cisco-Disconnect-Cause Lost-Carrier 11
#VALUE Cisco-Disconnect-Cause No-Detected-Result-Codes 12
#VALUE Cisco-Disconnect-Cause User-Ends-Session 20
#VALUE Cisco-Disconnect-Cause Idle-Timeout 21
#VALUE Cisco-Disconnect-Cause Exit-Telnet-Session 22
#VALUE Cisco-Disconnect-Cause No-Remote-IP-Addr 23

```

## RADIUS reply-message support

A reply-message is text that you create and configure in the **radiusd.conf** file.

It is intended for the NAS or AP to return as a string to the user. These can be a success, failure or challenge message. They are readable text fields and their contents are implementation-dependent and configured at server configuration time. The default for these attributes is no text. You may configure all, none, or one, two, or three attributes.

RADIUS supports the following Reply-Message Attributes:

- Accept Reply-Message
- Reject Reply-Message
- CHAP Reply-Message
- Password Expired Reply-Message

These attributes are added to the **radiusd.conf** configuration file and read into a global configuration structure at daemon start time. Set these values using SMIT RADIUS Panels as part of the **Configure Server** option. The maximum number of characters in each string is 256 bytes.

The function is implemented as follows:

1. When the **radiusd** daemon starts, it will read the **radiusd.conf** file and set the Reply-Message attributes.
2. When an access request packet is received, the user is authenticated.
3. If the authentication response is an access accept, then the Accept Reply-Message text is checked. If the text is present, the string is returned in the access accept packet.
4. If the authentication is rejected, then the Reject Reply-Message text is checked and returned in the access reject packet.
5. If the Authentication is challenged, then the CHAP Reply-Message attribute is checked and sent as part of the Access-Challenge packet.

## RADIUS server IP pool configuration

With the RADIUS server you can assign an IP address dynamically from an IP address pool.

IP address allocation is part of the authorization process and is done after authentication. The system administrator must assign a unique IP per user. To provide the user with an IP address dynamically, the RADIUS server provides three options:



- Framed Pool Attribute
- Using the Vendor Specific Attribute
- RADIUS Server Side IP pooling

## Framed Pool Attribute

The IP pool *poolname* must be defined on the Network Access Server (NAS). The NAS must be RFC2869-compliant for the RADIUS server to send an **Framed-Pool** attribute in an Access-Accept pack (type 88 attribute). The system administrator must configure the NAS and update the authorization attributes for the user by including the **Framed-Pool** attribute in either the global **default.auth** file or the **user.auth** file on the RADIUS server. The dictionary file in the RADIUS server includes this attribute:

```
ATTRIBUTE Framed-Pool 88 string
```

If the NAS cannot use multiple address pools, the NAS ignores this attribute. The address pool on the NAS contains a list of IP addresses. The NAS dynamically picks one of the IP addresses defined in the specified pool and assigns it to the user.

## Vendor Specific Attributes

Some independent software vendors (ISV) cannot use the **Framed-Pool** attribute, but do have the ability to define IP address pools. The RADIUS server can utilize these address pools by using the Vendor-Specific Attribute (VSA) model. For example, a Cisco NAS provides an attribute called Cisco-AVPair. The dictionary file in the RADIUS server includes this attribute:

```
VENDOR Cisco 9
ATTRIBUTE Cisco-AVPair 1 string
```

When the NAS sends an Access-Request packet, it includes this attribute with `Cisco-AVPair="ip:addr-pool=poolname"` where *poolname* is the name of the address pool defined on the NAS. After the request is authenticated and authorized, the RADIUS server returns the attribute in the Access-Accept packet. The NAS can then use the defined pool to allocate the IP address to the user. The system administrator must configure the NAS and update the authorization attributes for the user by including the VSA attribute in either the global **default.auth** file or the **user.auth** file on the RADIUS server.

## Radius Server Side IP Pooling

The RADIUS server can be configured to generate an IP address from a pool of IP addresses. The IP address is returned in the Framed-IP-Address attribute of the Access-Accept packet.

The system administrator can define a pool of IP addresses using the SMIT interface. The addresses are maintained in the **/etc/radius/ippool\_def** file. *Poolnames* are defined in the **etc/radius/clients** file. The system administrator must also configure the NAS-Port number. The RADIUS server daemon uses information from the **etc/radius/clients** and **/etc/radius/ippool\_def** files to create data files. Once the daemon starts, the system administrator cannot change or add the *poolnames* or IP address ranges until the RADIUS servers have stopped. When the RADIUS server daemon is started, it reads the configuration file (**/etc/radius/radius.conf**) and if IP Allocation is enabled (`Enable_IP_Pooling=YES`), sets the global IP allocation flag (`IP_pool_flag`) to On. The daemon then checks to see if the **poolname.data** file exists. If it does, it reads the file and keeps that information in shared memory. It then updates the file and shared memory based on the requests coming in from the clients. If the file does not exist, then the daemon creates a new file using information from the **etc/radius/clients** and the **/etc/radius/ippool\_def** files. The **poolname.data** file has a maximum size limit of 256 MB (AIX segment size limit). If the **poolname.data** file is more than 256 MB, the RADIUS server logs an error message and exits.

The daemon gets IP-pool details from the **/etc/radius/ippool\_def** file and maintains a table of IP addresses for each pool name in shared memory. The table has entries for NAS-IP-address, NAS-port and IN USE flag. The daemon maintains a hash table that is keyed by the NAS-IP NAS-port. When requests

come in from multiple users, the UDP queues the requests, and the daemon retrieves the NAS-IP and NAS-port data from the request. Using that information, it checks to see whether a *poolname* has been defined for that NAS by checking the information read from the **etc/radius/clients** file.

The daemon attempts to get an unused address from the pool. If an unused address is available, it is marked as “in use” by the NAS-IP and NAS-port flags, and is returned to the RADIUS server. The IP address is put into the **Framed-IP-Address** attribute by the daemon, and returned to the NAS in the accept packet. The **poolname.data** file is also updated to be in sync with the information in shared memory.

If the pool does not exist, or exists but does not have any more unused addresses, an error is returned to the RADIUS server. The error `Could not allocate IP address` is logged in the log file and an Access-Reject packet is sent to the NAS by the RADIUS server.

The error codes are:

- NOT\_POOLED – There is no pool defined for the **nas\_ip**.
- POOL\_EXHAUSTED – The pool is defined for the **nas\_ip**, but all of the addresses in the pool are currently in use.

When the authentication request comes from a NAS and NAS-port combination that already has an IP address allocated, the daemon returns the previous allocation to the pool, by marking the IN USE flag to Off, and clearing the NAS-IP-address and NAS-port entries in the table. It then allocates a new IP address from the pool.

The IP address is also returned to the pool when the RADIUS server receives an Accounting-Stop packet from the NAS. The Accounting-Stop packet must contain the NAS-IP-address and NAS-port entries. The daemon accesses the **ippool\_mem** file for the following cases:

- The request comes in to get a new IP address. Sets the IN USE flag to true.
- An Accounting-Stop packet is received. It releases the IP address by setting the “in use” flag to false.

In each case, the shared memory system calls ensure that the data in shared memory and the **poolname.data** files are in sync. The system administrator can turn IP allocation ON or OFF using the *Enable\_IP\_Pooling* parameter in the RADIUS server configuration file (**radiusd.conf**). This is useful in cases where the system admin has an assigned IP address in either the global **default.auth** or **user.auth** file. To use that assigned IP address, the system administrator must set `Enable_IP_Pool = NO`.

An example of an **/etc/radius/ippool\_def** file created through SMIT:

| Pool Name | Start Range   | End Range     |
|-----------|---------------|---------------|
| Floor5    | 192.165.1.1   | 192.165.1.125 |
| Floor6    | 192.165.1.200 | 192.165.1.253 |

The following is an example of an **/etc/radiusclients** file created through SMIT:

| NAS-IP  | Shared Secret | Pool Name |
|---------|---------------|-----------|
| 1.2.3.4 | Secret1       | Floor5    |
| 1.2.3.5 | Secret2       | Floor6    |
| 1.2.3.6 | Secret3       | Floor5    |
| 1.2.3.7 | Secret4       |           |

In the example above for the NAS-IP-Address 1.2.3.7, the pool name is blank. In this case, IP pooling is not done for this NAS (even if the global `IP_pool_flag = True`). When the Access-Request packet comes in, the RADIUS server does the authentication and authorization. If successful, it sends the static IP

address defined in the request, or from the global **default.auth** file or **user.auth** file, in the Access-Accept packet. In this case, the NAS-Port attribute is not required.

If IP pooling is True, the system administrator has also defined a static IP address as part of the global **default.auth** or **user.auth**, or as part of the Access-Request packet. The RADIUS server replaces that IP address with the IP address allocated from the defined pool name for that NAS. If all IP addresses in the pool are in use, the server logs the error (pool is full) and sends an Access-Reject packet. The server ignores any static IP address defined in the **auth** files.

If IP pooling is True and a valid pool name is defined for the NAS, when an Access-Request packet comes in from that NAS-IP, and it does not have the NAS-Port defined, the server sends a Access-Reject packet.

The following is an example of the **Floor5.data** file created by the daemon:

| IP Address    | NAS-IP  | NAS-Port | In Use |
|---------------|---------|----------|--------|
| 192.165.1.1   | 1.2.3.4 | 2        | 1      |
| 192.165.1.2   | 1.2.3.4 | 3        | 0      |
| .....         | .....   | ....     | ....   |
| 192.165.1.124 | 1.2.3.6 | 1        | 1      |
| 192.165.1.125 | 1.2.3.6 | 6        | 1      |

The following is an example of the **Floor6.data** file created by the daemon:

| IP Address    | NAS-IP  | NAS-Port | In Use |
|---------------|---------|----------|--------|
| 192.165.200   | 1.2.3.4 | 1        | 1      |
| 192.165.201   | 1.2.3.4 | 4        | 1      |
| .....         | .....   | ....     | ....   |
| 192.165.1.252 | 1.2.3.4 | 5        | 0      |
| 192.165.1.253 | 1.2.3.4 | 6        | 1      |

When it is necessary to release all allocated IP addresses for a specified NAS (for example, when a NAS stops), it might be necessary to release all the IP addresses from all the pools to initialize the **poolname.data** file. The system administrator can do with the following menu actions using SMIT:

- Clear IP Pool for a Client
- Clear entire IP Pool

### SMIT Panels for IP Pool

In Client Configuration, **Add a Client**, you can enter the optional **Pool Name**. The name can be a maximum of 64 characters. When the **Pool Name** is blank, IP pooling is not done and the RADIUS server assigns the IP address defined by the system administrator through the **Framed-IP-Address** authorization attribute.

When **IP Pool** is selected, the following options display:

- List all IP Pools
- Create an IP Pool
- Change/Show Characteristics of an IP Pool
- Delete an IP Pool
- Clear IP Pool for a Client

- Clear entire IP Pool

**List all IP Pools:** Use this option to list the **Pool Name, Start Range IP address** and **Stop Range IP address**.

**Create an IP Pool:** Use this option to add the pool name, start range, and end range. This data is appended to the bottom of the **ippool\_def** file. Checks are made to ensure there are no duplicate pool names and that the IP address ranges are disjoint. This action can only be performed when the RADIUS server daemons are not running.

**Change/Show Characteristics of an IP Pool:** This option shows a list of the pool names in a pop-up panel. From this panel, you must select a specific pool name. When you select a pool name, a panel with the selected name displays. When you press Enter, the data for that pool name is updated in the **ippool\_def** file. This action can only be performed when the RADIUS server daemons are not running.

**Delete an IP Pool:** Selecting this option displays a list of pool names that you can select. When you select the pool name, the **Are You Sure** pop-up panel displays to provide a confirmation before the selected pool name is deleted. The **rmippool** script is invoked to delete the selected pool name from the **ippool\_def** file. This action can only be performed when the RADIUS server daemons are not running.

**Clear IP Pool for a Client:** This option marks the **IN-USE** entry to 0 for the IP addresses that belong to the NAS, which means that all IP addresses for this NAS are now available. This action can only be done when the RADIUS server daemons are not running.

**Clear Entire IP Pool:** When this option is selected, an **Are You Sure** pop-up panel displays to provide a confirmation before the entire **ippool\_mem** file is cleared. This action can only be performed when the RADIUS server daemons are not running.

## RADIUS SMIT panels

When using SMIT to configure the RADIUS server, fields marked with an asterisk (\*) are required fields.

The SMIT fast-path is:

```
smitty radius
```

The RADIUS Main Menu is as follows:

```
RADIUS Server
```

```
Configure Server
Configure Clients
Configure Users
Configure Proxy Rules
Advanced Server Configuration
Start RADIUS Server daemons
Stop RADIUS Server daemons
```

The following screen capture shows a sample RADIUS Configure Server SMIT panel:

```

Configure Server

RADIUS Directory /etc/radius
*Database Location [UNIX]
Local AVL Database File Name [dbdata.bin]
Local Accounting [ON]
Local Accounting Directory []

Debug Level [3]
Accept Reply-Message []
Reject Reply-Message []
Challenge Reply-Message []
Password Expired Reply Message []
Support Renewal of Expired Passwords [NO]
Require Message Authenticator [NO]

*Authentication Port Number [1812]
*Accounting Port Number [1813]

LDAP Server Name []
LDAP Server Port Number [389]
LDAP Server Admin Distinguished Name []
LDAP Server Admin Password []
LDAP Base Distinguished Name [cn=aixradius]
LDAP Size Limit [0]
LDAP Hop Limit [0]
LDAP wait time limit [10]
LDAP debug level [0]

Proxy Allowed [OFF]
Proxy Use table [OFF]
Proxy Realm Name []
Proxy Prefix Delimiters [$/]
Proxy Suffix Delimiters [0.]
NOTE: prefix & suffix are mutually exclusive
Proxy Remove Hops [NO]
Proxy Retry Count [2]
Proxy Timeout [30]
UNIX Check Login Restrictions [OFF]
Enable IP Pool [ON]

```

Detailed SMIT help information is available for all fields and menu options by pressing the **F1** key.

## Random number generator

Random numbers are required when generating the Authenticator field of a RADIUS packet.

It is important to provide the best possible generator because an intruder could try to trick the RADIUS server into responding to a predicted request and then use the response to masquerade as that RADIUS server to a future access-request. The AIX RADIUS Server uses the **/dev/urandom** kernel extension to generate pseudo random numbers. This kernel extension collects entropy samples from hardware sources by way of the pseudo device driver. This device has been through NIST testing to ensure proper randomness.

## NLS enablement

The RADIUS **raddbm** command and the SMIT panels are NLS enabled and each uses the standard AIX NLS API calls to provide this function.

## Related information

Commands: **installp**, **mkuser**, and **raddbm**

## AIX Intrusion prevention

AIX intrusion prevention detects inappropriate, unauthorized or other data that might be considered harmful to a system.

The following section describes the various types of intrusion detection provided by AIX.

## Related information

Commands: **chfilt**, **ckfilt**, **expfilt**, **genfilt**, **impfilt**, **lsfilt**, **mkfilt**, **mvfilt**, **rmfilt**.

## Intrusion detection

Intrusion detection is the action of monitoring and analyzing system events in order to intercept and reject any attempt of unauthorized system access. In AIX, this detection of unauthorized access or attempted unauthorized access is done by observing certain actions, and then applying filter rules to these actions

**Note:** You must install the **bos.net.ipsec** filesets on the host system to enable intrusion detection. The detection technologies are built upon the existing AIX Internet Protocol Security (IPsec) features.

### *Pattern matching filter rules:*

Pattern matching is the use of an IPsec filter rule for filtering networking packets. A filter pattern can be a text string, a hexadecimal string, or a file containing more than one pattern. After a pattern filter rule is established and that pattern is detected in the body of any network packet, then the predefined action of the filter rule will result.

Pattern matching filter rules only apply to inbound network packets. Use the **genfilt** command to add a filter rule to the filter rule table. The filter rules generated by this command are called manual filter rules. Use the **mkfilt** command to activate or deactivate the filter rules. The **mkfilt** command can also be used to control the filter logging function.

A pattern file can contain a list, one per line, of text patterns or hexadecimal patterns. Pattern matching filter rules can be used to guard against viruses, buffer overflows, and other network security attacks.

Pattern matching filter rules can have a negative impact on system performance if they are used too broadly, and with a high number of patterns. It is best to keep the scope of their application as narrow as possible. For example, if a known virus pattern applies to **sendmail**, then specify the **sendmail** SMTP destination port 25 in the filter rule. This allows all other traffic to pass without incurring a performance impact from pattern matching.

The **genfilt** command recognizes and understands the pattern format used in some versions found at <http://www.clamav.net>.

### *Types of patterns:*

There are three basic types of patterns: text, hexadecimal, and file. Pattern matching filter rules apply to incoming packets only.

### **Text pattern**

A text filter pattern is an ASCII string that looks similar to the following:

```
GET ../../../../../../../../
```

### **Hexadecimal pattern**

A hexadecimal pattern looks similar to the following:

```
0x33c0b805e0cd16b807e0cd1650558becc7460200f05d0733ffb8c800b9ffff3abb00150
e670e47132c0e67158fec03c8075f033c033c9b002fa99cd26fb4183f90575f5c3
```

**Note:** A hexadecimal pattern is differentiated from a text pattern by the leading 0x.

## Files that contain text patterns

A file can contain a list, one per line, of text patterns or hexadecimal patterns. Sample pattern files can be found at <http://www.clamav.net>.

### ***Shun port and shun host filter rules:***

By setting a shun filter rule, you can affect a remote host or the remote host and port pair from accessing the local machine.

A shun filter rule dynamically creates an effect rule that denies the remote host or the remote host and port pair from accessing the local machine when the rule's specified criteria are met.

Because it is common for an attack to be preceded by a port scan, shun port filter rules are especially useful in preventing an intrusion by detecting this attack behavior.

For example, if the local host does not use the server port 37, which is the time server, then the remote host should not be accessing port 37, unless it is running a port scan. Place a shun port filter rule on port 37 so that if the remote host attempts to access that port, the shun filter rule creates an effective rule that blocks that host from further access for the amount of time specified shun rule **expiration time** field.

If a shun rule's **expiration time** field is set to 0, then the dynamically created effective shun rule does not expire.

#### **Note:**

1. An expiration time specified by the shun port filter rule applies only to the dynamically created effect rule.
2. Dynamically created effect rules can only be viewed with the **lsfilt -a** command.

### **Shun host filter rules**

When the criteria of a shun host filter rule is met, then the dynamically created effective rule will block or shun all network traffic from the remote host for the specified expiration time.

### **Shun port filter rules**

When the criteria of a shun port filter rule is met, then the dynamically created effective rule will only block or shun network traffic from this remote host's particular port, until the expiration time is exceeded.

### ***Stateful filter rules:***

Stateful filters examine information such as source and destination addresses, port numbers, and status. Then, by applying IF, ELSE or ENDIF filter rules to these header flags, stateful systems can make filtering decisions in the context of an entire session rather than that of an individual packet and its header information.

Stateful inspection examines incoming and outgoing communication packets. When stateful filter rules are activated with the **mkfilt -u** command, the rules in the ELSE block are always examined until the IF rule is satisfied. After the IF rule or condition is satisfied, the rules in the IF block are used until the filter rules are reactivated with the **mkfilt -u** command.

The **ckfilt** command will check the syntax of the stateful filter rules and display them in a display in a illustrative manner such as the following:

```
%ckfilt -v4
Beginning of IPv4 filter rules.
Rule 2
```

```
IF Rule 3
 IF Rule 4
 Rule 5
 ELSE Rule 6
 Rule 7
 ENDIF Rule 8
ELSE Rule 9
 Rule 10
ENDIF Rule 11
Rule 0
```

### ***Timed rules:***

Timed rules specify the amount of time, in seconds, that the filter rule is applied after it is made effective with the **mkfilt -v [416] -u** command.

The expiration time is specified with the **genfilt -e** command. For more information, see the **mkfilt** and **genfilt** commands.

**Note:** Timers have no effect on IF, ELSE or ENDIF rules. If an expiration time is specified in a shun host or shun port rule, the time applies only to the effect rule that is initiated by the shun rule. Shun rules have no expiration time.

### **Accessing filter rules from SMIT**

You can configure rules from SMIT.

To configure filter rules from SMIT, complete the following steps.

1. From a command line, enter the following command: `smitty ipsec4`
2. Select **Advanced IP Security Configuration**.
3. Select **Configure IP Security Filter Rules**.
4. Select **Add an IP Security Filter Rule**.



```

Add an IP Security Filter Rule

Type or select values in entry fields.
Press Enter AFTER making all desired changes.

[TOP]
* Rule Action [Entry Fields] [permit] +
* IP Source Address []
* IP Source Mask []
 IP Destination Address []
 IP Destination Mask []
* Apply to Source Routing? (PERMIT/inbound only) [yes] +
* Protocol [all] +
* Source Port / ICMP Type Operation [any] +
* Source Port Number / ICMP Type [0] #
* Destination Port / ICMP Code Operation [any] +
* Destination Port Number / ICMP Type [0] #
* Routing [both] +
* Direction [both] +
* Log Control [no] +
* Fragmentation Control [0] +
* Interface [] +
 Expiration Time (sec) [] #
 Pattern Type [none] +
 Pattern / Pattern File []
 Description []

Where "Pattern Type" may be one of the following
x none x#
x pattern x
x file x
x Anti-Virus patterns

```

The choices for the action field are: permit, deny, shun\_host, shun\_port, if, else, endif.

If a pattern file is specified, then it must be readable when the filter rules are activated with the **mkfilt -a** command. The filter rules are stored in the `/etc/security/ipsec_filter` database.

---

## AIX Security Expert

AIX Security Expert provides a center for all security settings (TCP, NET, IPSEC, system, and auditing).

AIX Security Expert is a system security hardening tool. AIX Security Expert provides simple menu settings for High Level Security, Medium Level Security, Low Level Security, and AIX Standard Settings security that integrate over 300 security configuration settings while still providing control over each security element for advanced administrators. AIX Security Expert can be used to implement the appropriate level of security, without the necessity of reading a large number of papers on security hardening and then individually implementing each security element.

AIX Security Expert can be used to take a security configuration snapshot. This snapshot of this security policy can be used to set up the same security configuration on other systems. This both saves time and ensures that all systems have the proper security configuration in an enterprise environment. It is also possible to check the security of a system which has been previously configured with AIX Security Expert. If any security configuration changes have been made outside the scope of AIX Security Expert, these changes will be reported.

During migration from AIX 5.3 to AIX 6.1, the `/etc/security/aixpert/core/appliedaixpert.xml` file will be preserved (if it exists) and converted to AIX 6.1 XML format. System administrators can later use this file with the **aixpert -f** option to apply the same security settings that are present on AIX 5.3 to AIX 6.1. This ability helps users keep the same security settings across AIX releases.

AIX 6.1 provides several new AIX Security Expert features:

- Secure by default
- Distributed security policy through AIX Security Expert and LDAP
- Customizable security policy through user-defined AIX Security Expert XML rules
- File permission manager **fpm** command for managing SUID programs
- Stringent check for weak passwords

AIX Security Expert relieves the system administrator from the need to be a security expert on a large array of products. AIX Security Expert also aids the system administrator in configurations required by government and security compliance standards. AIX Security Expert centralizes the configuration and control of system security and handles the interactions and interdependencies between different security components. This allows AIX Security Expert to present the system administrator with a simple, easy-to-use, security dashboard, where all of the complex configuration details and component interdependencies are resolved internally. This eliminates security vulnerabilities and service outages caused by human error during configuration.

AIX Security Expert can be run from Web-based System Manager, SMIT or you can use the **aixpert -c -l s** command.

## AIX Security Expert settings

The following coarse-grain security settings are available:

### High Level Security

High-level security

### Medium Level Security

Medium-level security

### Low Level Security

Low-level security

### Customized Options

Optional user defined XML security policy

### Distributed Security Options

Optional AIX Expert Security XML security policies distributed via LDAP

### Advanced Security Custom

User-specified security

### Default Security

Original system default security

### Undo Security

Some AIX Security Expert configuration settings can be undone

### Check Security

Provides a detailed report of current security settings

### SOX-COBIT Best Practices Security

Commonly accepted security configuration for SOX-COBIT compliance

### SOX-COBIT Best Practices Security Audit

Produce an audit report based on the system complying with the above configuration

## AIX Security Expert security hardening

Security hardening protects all elements of a system by tightening security or implementing a higher level of security.

Security hardening helps ensure that all security configuration decisions and settings are adequate and appropriate. Hundreds of security configuration settings might have to be changed to harden the security of an AIX system.

AIX Security Expert provides a menu to centralize effective common security configuration settings. These settings are based on extensive research on properly securing UNIX systems. Default security settings for broad security environment needs (High Level Security, Medium Level Security, and Low Level Security) are provided, and advanced administrators can set each security configuration setting independently.

Configuring a system at too high a security level might deny services that are needed. For example, **telnet** and **rlogin** are disabled for High Level Security because the login password is sent over the network unencrypted. If a system is configured at too low a security level, the system can be vulnerable to security threats. Since each enterprise has its own unique set of security requirements, the predefined High Level Security, Medium Level Security, and Low Level Security configuration settings are best suited as a starting point for security configuration rather than an exact match for the security requirements of a particular enterprise.

The practical approach to using AIX Security Expert, is to establish a test system (in a realistic test environment) similar to the production environment in which it will be deployed. Install necessary business applications and run AIX Security Expert via the GUI. The AIX Security Expert will analysis this running system in this trusted state. Depending on the security options you chose, AIX Security Expert will enable port scan protection will be enabled, turn on auditing, block network ports that are not in use by the business applications or other services, along with many other security settings. After re-testing with these security configurations in place, the system is ready to be deployed in a production environment. Also, the AIX Security Expert XMLfile defining the security policy or configuration of this system can be easily be used to implement the exact same configuration on similar systems in your enterprise.

For more information on security hardening, see NIST Special Publication 800-70, NIST Security Configurations Checklist Program for IT Products.

## Secure by default

Secure By Default (SbD) is the concept of installing a minimal set of software in a secure configuration.

The AIX Secure by Default (SbD) installation option installs a lighter version of the TCP client and server filesets, that excludes vulnerable commands and files. The **bos.net.tcp.client** and **bos.net.tcp.server** filesets are part of the SbD installation and contain all commands and files except for any applications that allow for the transmission of passwords over the network in clear text format such as **telnet** and **ftp**. In addition, applications that might be exploited, such as **rsh**, **rcp**, and **sendmail**, are excluded from the SbD filesets.

The final automated process of the SbD install is to impose the AIX Security Expert high-level security configuration settings. You can do this by running the **aixpert** command from **/etc/firstboot** script:  

```
/usr/sbin/aixpert -f /etc/security/aixpert/core/SbD.xml -p 2>/etc/security/aixpert/log/firstboot.log
```

It is possible to move the machine out of SbD mode by changing the ODM variable *SbD\_STATE* to *sbd\_disable*, installing the **bos.net.tcp.client** and **bos.net.tcp.server** filesets again, and using the AIX Security Expert to bring the system to its default security level.

It is not possible to use migration install or preservation install to achieve a SbD installed system. SbD is a separate install menu path.

It is possible to have a securely configured system without using the SbD install option. For example, the AIX Security Expert High, Medium, or Low level security options can be configured on a regular install.

The differences between an SbD-installed system and a regular install with an AIX Security Expert High Level Security configuration is best illustrated by examining the **telnet** command. In both cases, the **telnet** command is disabled. In an SbD installation, the **telnet** binary or application is never even installed on the system.

When the SbD install is used, the following services are removed from the system at install time. With these services removed from the system, it is not possible to access or run these commands from the system. If these commands and programs are needed, do not use the SbD install option. In addition, if any scripts, remote programs, or dependent filesets require these commands and programs, do not use the SbD install option.

| Name    | Program                            | Arguments                                           |
|---------|------------------------------------|-----------------------------------------------------|
| ftp     | /usr/sbin/ftpd                     | ftpd                                                |
| telnet  | /usr/sbin/telnetd                  | telnetd -a                                          |
| shell   | /usr/sbin/rshd                     | rshd                                                |
| login   | /usr/sbin/rlogind                  | rlogind                                             |
| exec    | /usr/sbin/rexecd                   | rexecd                                              |
| comsat  | /usr/sbin/comsat                   | comsat                                              |
| uucp    | /usr/sbin/uucpd                    | uucpd                                               |
| bootps  | /usr/sbin/bootpd                   | bootpd /etc/bootp                                   |
| finger  | /usr/sbin/fingerd                  | fingerd                                             |
| systat  | /usr/bin/ps                        | ps -ef                                              |
| netstat | /usr/bin/netstat                   | netstat -f inet                                     |
| tftp    | /usr/sbin/tftpd                    | tftpd -n                                            |
| talk    | /usr/sbin/talkd                    | talkd                                               |
| ntalk   | /usr/sbin/talkd                    | talkd                                               |
| rquotad | /usr/sbin/rpc.rquotad              | rquotad                                             |
| rexcd   | /usr/sbin/rpc.rexd                 | rexcd                                               |
| rstatd  | /usr/sbin/rpc.rstatd               | rstatd                                              |
| rusersd | /usr/lib/netsvc/rusers/rpc.rusersd | rusersd                                             |
| rwalld  | /usr/lib/netsvc/rwall/rpc.rwalld   | rwalld                                              |
| sprayd  | /usr/lib/netsvc/spray/rpc.sprayd   | sprayd                                              |
| pcnfsd  | /usr/sbin/rpc.pcnfsd               | pcnfsd                                              |
| instsrv | /u/netinst/bin/instsrv             | instsrv -r /tmp/netinstalllog<br>/u/netinst/scripts |

## Distributing security policy through LDAP

LDAP can be used to distribute AIX Security Expert XML configuration files. You can use AIX Security Expert to copy a security configuration from one system to another. This allows for similar systems to have the same security configuration. This consistency can reduce security vulnerabilities.

The recommended practice is to use AIX Security Expert to configure a single system and set the security level in accordance with corporate security policies and the environment in which the system will operate. This configuration is captured in the **/etc/security/aixpert/core/appliedaixpert.xml** file. This file can then be moved to a configured and trusted LDAP server. Other systems with connectivity to this LDAP server will automatically discover this XML configuration file via the **aixpert websm** menus or the **aixpertldap** command.

Any existing LDAP Server can be updated with the aixpert schema to distribute the aixpert configuration XML files onto each client connected. If the LDAP server does not have the aixpert schema updated, update the aixpert schema onto LDAP with the following command: `ldapmodify -c -D <bindDN> -w <bindPwd> -i /etc/security/ldap/sec.ldif` Once the LDAP server is updated with aixpert schema, clients can place their XML configuration files on LDAP using the -u option of the **aixpertldap** command. These configuration files needs to be updated manually, otherwise the Distributed Security option of WebSM will not be able to provide users with any menus.

**Note:** This feature relies on the trust model LDAP has in place. Users who have privileges to write to LDAP can modify the data uploaded by users of a different machine. Similarly, if an LDAP client has a security vulnerability, then this can be exploited to read and understand the security status of other LDAP clients by reading the AIX Security Expert XML configuration files associated with the client.

For example, an **appliedaixpert.xml** file can be saved on the LDAP server under the name **BranchOfficeSecurityProfile**. Or a differently configured **appliedaixpert.xml** file might be saved under the name **InternetDirectAttachedSystemsProfile**. As other systems with LDAP connectivity are configured with AIX Security Expert, these security profiles are automatically presented as menu options. This allows the system administrator to select the security profile which best suites their environment within the guidelines of their corporate security policies.

Then AIX Security Expert is used to secure a system. The complete list of security configuration settings implemented on the system is captured in the file **/etc/security/aixpert/core/appliedaixpert.xml**. This file is the security policy for this system. The security policy is compared when the AIX Security Expert Check Security option is used. This security policy can also be copied and applied to other systems, which provides consistency in the security of systems throughout your IT environment. There are two ways to copy a security policy onto other systems, manually or through LDAP.

### **AIX Security Expert security policy copy**

You can use AIX Security Expert to copy a security policy from one system to another.

You can run AIX Security Expert on one system and apply the same security policy on other systems. For example, Bob wishes to apply AIX Security Expert on his six AIX systems. He applies the security settings on one system (Alpha) with High, Medium, Low, Advanced, or AIX Standard Settings security. He tests this system for compatibility issues within his environment. If he is satisfied with these settings, he can apply the same settings on the other AIX systems by name. He copies the settings from the system Alpha to the system where he wants to apply the same security settings by copying the **/etc/security/aixpert/core/appliedaixpert.xml** file from Alpha to the other system.

**Note:** Do not copy this file to the same directory and filename on the other system, because the **aixpert** command will write over **/etc/security/aixpert/core/appliedaixpert.xml** as it implements the security policy.

Instead, copy Alpha's security policy to the **/etc/security/aixpert/custom/** directory. This allows the other system to view and apply Alpha's security policy through the AIX Security Expert system management GUI, or directly with the **aixpert** command.

For example, if the Alpha's **appliedaixpert.xml** security policy was placed on the other systems as **/etc/security/aixpert/custom/AlphaPolicy**, then the command `aixpert -f /etc/security/aixpert/custom/AlphaPolicy` would immediately apply this security policy and this system would have the same security configuration as machine Alpha. Additionally, when Alpha's security policy is in this directory, it is visible and can be applied through the other systems system management console via the path of AIX Security Expert -> Overview and Tasks -> Customized Options -> AlphaPolicy.

## Customizable security policy with user-defined AIX Security Expert XML rules

You can use XML files to configure unique security policies.

AIX Security Expert dynamically recognizes these XML files and incorporates them in the **websm** menus. This allows unique security policies and third-party applications to be configured with **websm**. Any custom XML security policy files created should be placed in the directory **/etc/security/aixpert/custom/** with a descriptive file. Therefore, when AIX Security Expert is accessed via a console graphical interface, the rich set of graphical XML features in the aixpert DTD will be fully realized.

The DTD is as follows:

```
<?xml version='1.0'?>

<!--START-->

<!ELEMENT AIXPertSecurityHardening (AIXPertEntry+)>

<!-- AIXPertEntry should contain only one instance of the following elements. -->

<!ELEMENT AIXPertEntry (AIXPertRuleType,
 AIXPertDescription, AIXPertPrereqList, AIXPertCommand,
 AIXPertArgs,AIXPertGroup)>

<!-- AIXPertEntry's name should be unique. -->

<!ATTLIST AIXPertEntry
 name ID #REQUIRED
 function CDATA ""
>

<!ELEMENT AIXPertRuleType EMPTY>
<!ATTLIST AIXPertRuleType type (LLS|MLS|HLS|DLS|SCBPS|Prereq) "DLS">
<!ELEMENT AIXPertDescription (#PCDATA)>
<!ELEMENT AIXPertPrereqList (#PCDATA)>
<!ELEMENT AIXPertCommand (#PCDATA)>
<!ELEMENT AIXPertArgs (#PCDATA)*>
<!ELEMENT AIXPertGroup (#PCDATA)*>
```

The AIXPertEntry name is a unique name within the XML file. This name will be the name of the selectable graphic button when this file is viewed via a system console via the path AIX Security Expert -> Overview and Tasks -> Customized Options -> `<xml file=""></xml>`.

### **<!ELEMENT AIXPertRuleType EMPTY>**

This XML file should be specified as custom.

### **<!ATTLIST AIXPertRuleType type (LLS|MLS|HLS|DLS|SCBPS|Prereq|Custom) "DLS"**

This XML file should be specified as custom.

### **<!ELEMENT AIXPertDescription (#PCDATA)>**

When viewed via the above mentioned graphical interface, the description text is displayed as a pop-up window then the mouse is placed on this button.

### **<!ELEMENT AIXPertPrereqList (#PCDATA)>**

It is possible to select a prerequisite rule to this rule. The prerequisite rule must return 0, before aixpert will implement this rule. If this XML file is viewed through a graphical interface, this rule will be grayed-out if the prerequisite rule is not satisfied. If you are creating a prerequisite rule, the AIXPertRuleType must be 'Prereq'.

The AIXPertDescription field of the prerequisite rule should describe what should be done to satisfy the prereq rule. If the Custom rules is grayed-out because one of its Prereq rules is not satisfied, then the user is shown the description pop-up window of the Prereq rule, which explains what the user must do to correct the prerequisite condition.

#### <!ELEMENT AIXPertCommand (#PCDATA)>

This element must be the full path and command which aixpert will execute for this security rule, e.g. /usr/bin/ls.

#### <!ELEMENT AIXPertArgs (#PCDATA)\*>

This element must contain any arguments to the above command, e.g. -l

#### <!ELEMENT AIXPertGroup (#PCDATA)\*>

It is possible to group a set of aixpert rules when they are displayed via a graphical interfaces. For example, a common set of rules might all specify a AIXPertGroup name of "Network Security".

## Stringent check for weak passwords

This AIX feature checks for weak passwords when passwords are changed. If this option is selected with AIX Security Expert, this additional password check is performed when a user selects or changes their password. This check guards against the use of English dictionary words and the 1000 most common US first names based on a recent US Census.

## COBIT control objectives supported by AIX Security Expert

AIX Security Expert supports the SOB-COBIT Best Practices Security level in addition to the High, Medium, Low, AIX Default and Advanced Security settings.

The United States Congress enacted the 'Sarbanes-Oxley Act of 2002' to protect investors by improving the accuracy and reliability of financial information disclosed by corporations. The COBIT control objectives feature will help System Administrators to configure, maintain, and audit their IT systems for compliance with this law. The SOX Configuration Assistant is accessed thru the AIX Security Expert web menu or the aixpert command line. The feature assists with the SOX section 404 of the Sarbanes-Oxley Act, but The AIX Security Expert SOX Configuration Assistant automatically implements security settings commonly associated with COBIT best practices for SOX Section 404, Internal Controls. Additionally, the AIX Security Expert provides a SOX audit feature which reports to the auditor whether the system is currently configured in this manner. The feature allows for the automation of system configuration to aid in IT SOX compliance and in the automation of the audit process.

Since SOX does not offer guidance on how IT must comply with section 404, the IT industry has focused on the existing governance detailed by [www.isaca.org/](http://www.isaca.org/). More specifically, the IT governance covered by Control Objectives for Information and related Technology (COBIT).

AIX Security Expert supports the following control objectives:

- Password policy enforcement
- Violation and Security Activity Reports
- Malicious software prevention, detection and correction, and unauthorized software
- Firewall architecture and connections with public networks

AIX Security Expert does not support all of the attributes specified under each control objective. The supported attributes and their respective control objectives are summarized in the following tables:

### Password policy enforcement

| Description                    | Security setting |
|--------------------------------|------------------|
| Maximum password age           | maxage=13        |
| Enforce password history       | histsize=20      |
| Minimum password age           | minage=1         |
| Minimum password length        | minlen=8         |
| Contains at least 6 characters | Minalpha=6       |

| Description                      | Security setting |
|----------------------------------|------------------|
| Similarity to old password       | mindiff=4        |
| Password expiration warning days | pwdwarntime=14   |

## Security violations and activity report

| Description                              | Security setting | Remarks                                                                           |
|------------------------------------------|------------------|-----------------------------------------------------------------------------------|
| Auditing Enabled                         | yes              |                                                                                   |
| No direct root logins                    | yes              |                                                                                   |
| Enable auditing for privilege escalation | yes              | AIXpert leverages the USER_SU audit event. Please ensure this event is turned on. |

## Malicious software detection and correction

AIX Security Expert leverages the AIX trusted software execution feature to ensure that the software is not tampered with by anyone. The **trustchk** command checks the consistency of the objects that are registered in the Trusted Software database.

## Firewall setup

AIX Security Expert turns on IPSec and enables filter rules to avoid port scans. The ports that are shunned are listed in the following table:

| Service                  | Description                             |
|--------------------------|-----------------------------------------|
| Tcp/11, udp/11           | Systat                                  |
| Tcp/13, udp/13           | Daytime                                 |
| (RFC 867) Tcp/19, udp/19 | Character Generator                     |
| Tcp/25                   | Simple Mail Transfer (SMTP)             |
| Tcp/43, udp/43           | Who Is (nickname)                       |
| Tcp/63, udp/63           | Whois++                                 |
| Tcp/67, udp/67           | Bootstrap protocol server (bootps)      |
| Tcp/68, udp/68           | Bootstrap protocol client (bootpc)      |
| Tcp/69, udp/69           | Trivial file transfer                   |
| (tftp) Tcp/79, udp/79    | Finger                                  |
| Tcp/87                   | Private Terminal Link                   |
| Tcp/110                  | Post office protocol – version 3 (POP3) |
| Udp/111                  | SUN Remote Procedure Call               |
| Tcp/113                  | Authentication Service (auth)           |
| Udp/123                  | Network Time Protocol                   |
| Udp/161                  | SNMP                                    |
| Udp/162                  | SNMPTRAP                                |
| Tcp/194                  | Internet Relay chat Protocol            |
| Tcp/443                  | http protocol over TLS/SSL              |
| Tcp/511                  | PassGo                                  |



| Service  | Description                     |
|----------|---------------------------------|
| Tcp/514  | Cmd (shell)                     |
| Tcp/520  | Extended file name server (efs) |
| Tcp/540  | Uucpd (uucp)                    |
| Tcp/546  | DHCPv6 Client                   |
| Tcp/547  | DHCPv6 Server                   |
| Tcp/555  | Dsf                             |
| tcp/559  | TEEDTAP                         |
| tcp/593  | HTTP RPC Ep Map                 |
| udp/635  | RLS Dbase                       |
| tcp/666  | Mdqs                            |
| tcp/777  | Multiling HTTP                  |
| tcp/901  | SNMPNSMERES                     |
| tcp/902  | IDEAFARM-CHAT                   |
| tcp/903  | IDEAFARM-CATCH                  |
| tcp/1024 | Reserved                        |

## Applying COBIT control objectives using AIX Security Expert

You can use the **aixpert -l s** command to apply the SCBPS level to the system. The audit log for this can be generated by turning on the **AIXpert\_apply** event. Any failures (either a prerequisite failure or an apply failure) are reported to **stderr** and the audit subsystem if enabled.

## SOX-COBIT compliance checking, audit, and pre-audit feature

You can use the **aixpert -c -l s** command to check a system's SOX-COBIT compliance. AIX Security Expert only checks for the supported control objectives compliance. Any violations found during the checking are reported. By default, any violations are sent to **stderr**.

You can also use the same command (**aixpert -c -l s**) to generate the SOX-COBIT compliance audit report. To generate an audit report, set up and enable the audit subsystem. Ensure that the **AIXpert\_check** audit event is turned on. After setting up the audit subsystem, rerun the **aixpert -c -l s** command. The command generates the audit log for every failed control objective. The **Status** field of the audit log will be marked as **failed**. The log also contains the reason for the failure, which can be viewed using the **-v** option of **auditpr** command.

Adding **-p** option to the **aixpert -c -l s** command also includes successful control objectives also in the audit report. Those log entries have **Ok** in the status field.

The **aixpert -c -l s -p** command can be used to generate a detailed SOX-COBIT compliance audit report.

Whether or not the **-p** option is specified, there will be a summary record. The summary record includes information about the number of rules processed, the number of failed rules (instances of non-compliance found), and the security level that the system is checked for (in this instance, this would be SCBPS).

## AIX Security Expert Password Policy Rules group

AIX Security Expert provides specific rules for password policy.

Strong password policies are one of the building blocks for achieving system security. Password policies ensure that passwords are difficult to guess (passwords have a proper mix of alphanumeric characters,

digits, and special characters), expire regularly, and are not reusable after expiration. The following table lists the password policy rules for each security setting.

Table 14. AIX Security Expert Password Policy Rules

| Action button name                             | Definition                                                                                                                                                                                       | Value set by AIX Security Expert                                                                                                                                  | Undo |
|------------------------------------------------|--------------------------------------------------------------------------------------------------------------------------------------------------------------------------------------------------|-------------------------------------------------------------------------------------------------------------------------------------------------------------------|------|
| <b>Minimum number of characters</b>            | Sets appropriate value to <b>mindiff</b> attribute of <b>/etc/security/user</b> , which specifies the minimum number of characters required in a new password that were not in the old password. | <b>High Level Security</b><br>4<br><b>Medium Level Security</b><br>3<br><b>Low Level Security</b><br>No effect<br><b>AIX Standard Settings</b><br>No limit        | Yes  |
| <b>Minimum age for password</b>                | Sets appropriate value to <b>minage</b> attribute of <b>/etc/security/user</b> , which specifies the minimum number of weeks before a password can be changed.                                   | <b>High Level Security</b><br>1<br><b>Medium Level Security</b><br>No limit<br><b>Low Level Security</b><br>No effect<br><b>AIX Standard Settings</b><br>No limit | Yes  |
| <b>Maximum age for password</b>                | Sets appropriate value to <b>maxage</b> attribute of <b>/etc/security/user</b> , which specifies the maximum number of weeks before a password can be changed.                                   | <b>High Level Security</b><br>13<br><b>Medium Level Security</b><br>13<br><b>Low Level Security</b><br>52<br><b>AIX Standard Settings</b><br>No limit             | Yes  |
| <b>Minimum length for password</b>             | Sets appropriate value to <b>minlen</b> attribute of <b>/etc/security/user</b> , which specifies the minimum length of a password.                                                               | <b>High Level Security</b><br>8<br><b>Medium Level Security</b><br>8<br><b>Low Level Security</b><br>8<br><b>AIX Standard Settings</b><br>No limit                | Yes  |
| <b>Minimum number of alphabetic characters</b> | Sets appropriate value to <b>minalpha</b> attribute of <b>/etc/security/user</b> , which specifies the minimum number of alphabetic characters in a password.                                    | <b>High Level Security</b><br>2<br><b>Medium Level Security</b><br>1<br><b>Low Level Security</b><br>No effect<br><b>AIX Standard Settings</b><br>No limit        | Yes  |

Table 14. AIX Security Expert Password Policy Rules (continued)

| Action button name                                   | Definition                                                                                                                                                                                                | Value set by AIX Security Expert                                                                                                                            | Undo |
|------------------------------------------------------|-----------------------------------------------------------------------------------------------------------------------------------------------------------------------------------------------------------|-------------------------------------------------------------------------------------------------------------------------------------------------------------|------|
| <b>Password reset time</b>                           | Sets appropriate value to <b>histexpire</b> attribute of <b>/etc/security/user</b> , which specifies the number of weeks before a password can be reset.                                                  | <b>High Level Security</b><br>26<br><b>Medium Level Security</b><br>26<br><b>Low Level Security</b><br>52<br><b>AIX Standard Settings</b><br>No limit       | Yes  |
| <b>Maximum times a char can appear in a password</b> | Sets appropriate value to <b>maxrepeats</b> attribute of <b>/etc/security/user</b> , which specifies the maximum number of times a character can appear in a password.                                    | <b>High Level Security</b><br>2<br><b>Medium Level Security</b><br>No effect<br><b>Low Level Security</b><br>No effect<br><b>AIX Standard Settings</b><br>8 | Yes  |
| <b>Password reuse time</b>                           | Sets appropriate value to <b>histsize</b> attribute of <b>/etc/security/user</b> , which specifies the number of previous passwords that a user cannot reuse.                                             | <b>High Level Security</b><br>20<br><b>Medium Level Security</b><br>4<br><b>Low Level Security</b><br>4<br><b>AIX Standard Settings</b><br>No limit         | Yes  |
| <b>Time to change password after the expiration</b>  | Sets appropriate value to <b>maxexpired</b> attribute of <b>/etc/security/user</b> , which specifies the maximum number of weeks after <b>maxage</b> that an expired password can be changed by the user. | <b>High Level Security</b><br>2<br><b>Medium Level Security</b><br>4<br><b>Low Level Security</b><br>8<br><b>AIX Standard Settings</b><br>-1                | Yes  |
| <b>Minimum number of non-alphabetic characters</b>   | Sets appropriate value to <b>minother</b> attribute of <b>/etc/security/user</b> , which specifies the minimum of non-alphabetic characters in a password.                                                | <b>High Level Security</b><br>2<br><b>Medium Level Security</b><br>1<br><b>Low Level Security</b><br>No effect<br><b>AIX Standard Settings</b><br>No limit  | Yes  |

Table 14. AIX Security Expert Password Policy Rules (continued)

| Action button name                      | Definition                                                                                                                                                                                      | Value set by AIX Security Expert                                                                                                                     | Undo |
|-----------------------------------------|-------------------------------------------------------------------------------------------------------------------------------------------------------------------------------------------------|------------------------------------------------------------------------------------------------------------------------------------------------------|------|
| <b>Password expiration warning time</b> | Sets appropriate value to <b>pwdwarntime</b> attribute of <b>/etc/security/user</b> , which specifies the number of days before the system issues a warning that a password change is required. | <b>High Level Security</b><br>14<br><b>Medium Level Security</b><br>14<br><b>Low Level Security</b><br>5<br><b>AIX Standard Settings</b><br>No limit | Yes  |

## AIX Security Expert User Group System and Password definitions group

AIX Security Expert performs specific actions for user, group, and password definitions.

Table 15. AIX Security Expert User Group System and Password Definitions

| Action button name             | Description                                                                                                                                        | Value set by AIX Security Expert                                                                                                                          | Undo |
|--------------------------------|----------------------------------------------------------------------------------------------------------------------------------------------------|-----------------------------------------------------------------------------------------------------------------------------------------------------------|------|
| <b>Check group definitions</b> | Verifies the correctness of group definitions. Runs the following command to fix and report errors:<br>% grpck -y ALL                              | <b>High Level Security</b><br>Yes<br><b>Medium Level Security</b><br>Yes<br><b>Low Level Security</b><br>Yes<br><b>AIX Standard Settings</b><br>No effect | No   |
| <b>TCB update</b>              | Uses the <b>tcback</b> command to verify and update TCB. Runs the following command:<br>% tcback -y ALL                                            | <b>High Level Security</b><br>Yes<br><b>Medium Level Security</b><br>Yes<br><b>Low Level Security</b><br>Yes<br><b>AIX Standard Settings</b><br>Yes       | No   |
| <b>Check file definitions</b>  | Uses the <b>sysck</b> command to check and fix the file base of <b>/etc/objrepos/inventory</b> :<br>% sysck -i -f \<br>/etc/security/sysck.cfg.rte | <b>High Level Security</b><br>Yes<br><b>Medium Level Security</b><br>Yes<br><b>Low Level Security</b><br>Yes<br><b>AIX Standard Settings</b><br>No effect | No   |

Table 15. AIX Security Expert User Group System and Password Definitions (continued)

| Action button name                | Description                                                                                                              | Value set by AIX Security Expert                                                                                                                          | Undo |
|-----------------------------------|--------------------------------------------------------------------------------------------------------------------------|-----------------------------------------------------------------------------------------------------------------------------------------------------------|------|
| <b>Check password definitions</b> | Verifies the correctness of password definitions. Runs the following command to fix and report errors:<br>% pwdck -y ALL | <b>High Level Security</b><br>Yes<br><b>Medium Level Security</b><br>Yes<br><b>Low Level Security</b><br>Yes<br><b>AIX Standard Settings</b><br>No effect | No   |
| <b>Check user definitions</b>     | Verifies correctness of user definitions. Runs the following command to fix and report errors:<br>% usrck -y ALL         | <b>High Level Security</b><br>Yes<br><b>Medium Level Security</b><br>Yes<br><b>Low Level Security</b><br>Yes<br><b>AIX Standard Settings</b><br>No effect | No   |

## AIX Security Expert Login Policy Recommendations group

AIX Security Expert provides specific settings for login policy.

**Note:** To ensure better accountability of security-related activities that are performed by root, it is recommended that users first log in using their normal user ID and then run the **su** command to run commands as root, rather than logging in as root. The system can then associate different users to activities performed using the root account when multiple users know and use the root password.

Table 16. AIX Security Expert Login Policy Recommendations

| Action button name                                         | Description                                                                                                                                                                                                                                                                                                                                                                                                                 | Value set by AIX Security Expert                                                                                                                              | Undo |
|------------------------------------------------------------|-----------------------------------------------------------------------------------------------------------------------------------------------------------------------------------------------------------------------------------------------------------------------------------------------------------------------------------------------------------------------------------------------------------------------------|---------------------------------------------------------------------------------------------------------------------------------------------------------------|------|
| <b>Interval between unsuccessful logins</b>                | Sets appropriate value to <b>logininterval</b> attribute of <b>/etc/security/login.cfg</b> , which specifies the time interval (in seconds) during which the unsuccessful login attempts for a port must occur before the port is disabled. For example, if <b>logininterval</b> is set to 60 and <b>logindisable</b> is set to 4, the account is disabled if there are four unsuccessful login attempts within one minute. | <b>High Level Security</b><br>300<br><b>Medium Level Security</b><br>60<br><b>Low Level Security</b><br>No effect<br><b>AIX Standard Settings</b><br>No limit | Yes  |
| <b>Number of login attempts before locking the account</b> | Sets appropriate value to <b>loginretries</b> attribute of <b>/etc/security/user</b> , which specifies the number of consecutive login attempts per account before the account is disabled. Do not set on root.                                                                                                                                                                                                             | <b>High Level Security</b><br>3<br><b>Medium Level Security</b><br>5<br><b>Low Level Security</b><br>No effect<br><b>AIX Standard Settings</b><br>No limit    | Yes  |

Table 16. AIX Security Expert Login Policy Recommendations (continued)

| Action button name                                     | Description                                                                                                                                                                                                                                                                                                                                                                                                                                                                                                       | Value set by AIX Security Expert                                                                                                                               | Undo |
|--------------------------------------------------------|-------------------------------------------------------------------------------------------------------------------------------------------------------------------------------------------------------------------------------------------------------------------------------------------------------------------------------------------------------------------------------------------------------------------------------------------------------------------------------------------------------------------|----------------------------------------------------------------------------------------------------------------------------------------------------------------|------|
| <b>Remote root login</b>                               | Changes the value of <b>rlogin</b> attribute of <b>/etc/security/user</b> , which specifies whether remote login is allowed or not on the system for root account.                                                                                                                                                                                                                                                                                                                                                | <b>High Level Security</b><br>False<br><b>Medium Level Security</b><br>False<br><b>Low Level Security</b><br>No effect<br><b>AIX Standard Settings</b><br>True | Yes  |
| <b>Re-enable login after locking</b>                   | Sets appropriate value to <b>loginreenable</b> attribute of <b>/etc/security/login.cfg</b> , which specifies the time interval (in seconds) after which a port is unlocked after the port is disabled by <b>logindisable</b> .                                                                                                                                                                                                                                                                                    | <b>High Level Security</b><br>360<br><b>Medium Level Security</b><br>30<br><b>Low Level Security</b><br>No effect<br><b>AIX Standard Settings</b><br>No limit  | Yes  |
| <b>Disable login after unsuccessful login attempts</b> | Sets appropriate value to <b>logindisable</b> attribute of <b>/etc/security/login.cfg</b> , which specifies the number of unsuccessful login attempts on a port before the port is locked.                                                                                                                                                                                                                                                                                                                        | <b>High Level Security</b><br>10<br><b>Medium Level Security</b><br>10<br><b>Low Level Security</b><br>No effect<br><b>AIX Standard Settings</b><br>No limit   | Yes  |
| <b>Login timeout</b>                                   | Sets appropriate value to <b>logintimeout</b> attribute of <b>/etc/security/login.cfg</b> , which specifies the time interval allowed to type in a password.                                                                                                                                                                                                                                                                                                                                                      | <b>High Level Security</b><br>30<br><b>Medium Level Security</b><br>60<br><b>Low Level Security</b><br>60<br><b>AIX Standard Settings</b><br>60                | Yes  |
| <b>Delay between unsuccessful logins</b>               | Sets appropriate value to <b>logindelay</b> attribute of <b>/etc/security/login.cfg</b> , which specifies the delay (in seconds) between unsuccessful logins. An additional delay period is added after each failed login. For example, if <b>logindelay</b> is set to 5, the terminal will wait five seconds after the first failed login until the next request. After a second failed login, the terminal will wait 10 seconds (2*5), and after a third failed login, the terminal will wait 15 seconds (3*5). | <b>High Level Security</b><br>10<br><b>Medium Level Security</b><br>5<br><b>Low Level Security</b><br>5<br><b>AIX Standard Settings</b><br>No limit            | Yes  |

Table 16. AIX Security Expert Login Policy Recommendations (continued)

| Action button name | Description                                                                                                                                                        | Value set by AIX Security Expert                                                                                                                                   | Undo |
|--------------------|--------------------------------------------------------------------------------------------------------------------------------------------------------------------|--------------------------------------------------------------------------------------------------------------------------------------------------------------------|------|
| <b>Local login</b> | Changes the value of <b>login</b> attribute of <b>/etc/security/user</b> , which specifies whether console login is allowed or not on the system for root account. | <b>High Level Security</b><br>False<br><b>Medium Level Security</b><br>No effect<br><b>Low Level Security</b><br>No effect<br><b>AIX Standard Settings</b><br>True | Yes  |

## AIX Security Expert Audit Policy Recommendations group

AIX Security Expert provides specific audit policy settings.

As with other security settings, bin auditing also needs the analysis (prerequisite) rules to be satisfied before applying any audit rules for High, Medium, or Low Level Security. The following analysis rules need to be satisfied for bin auditing:

1. The prerequisite rule to audit must check to see that audit is not currently running. If auditing is already running, then audit has been previously configured and AIX Security Expert must not alter the existing audit configuration and procedure.
2. There must be at least 100 megabytes of free space in a volume group that is automatically varied on or the **/audit** filesystem must currently exist with a size of 100 megabytes or more.

If the above prerequisite conditions are met, and the audit options is selected with in AIX Security Expert, then AIX Security Expert will configure and enable auditing on the system in the following manner. The AIX Security Expert **Enable binaudit** action button sets audit policy. Auditing must be enabled on the system.

1. The **/audit** JFS file system must be created and mounted before starting audit. The file system must have a size of at least 100 megabytes.
2. Audit must be run in bin mode. The **/etc/security/audit/config** file must be configured as follows:

```
start:
 binmode = on
 streammode = off
bin:
 trail = /audit/trail
 bin1 = /audit/bin1
 bin2 = /audit/bin2
 binsize = 10240
 cmds
= /etc/security/audit/bincmds
.
.
etc
```

3. Add the auditing entries for root and normal user for High, Medium, and Low Level Security.
4. Audit must be enabled on reboot for High, Medium, and Low Level Security.
5. New users created must have audit enabled for High, Medium, and Low Level Security. This can be done by adding an **auditclasses** entry to the user stanza in the **/usr/lib/security/mkuser.default** file.
6. A **cronjob** must be added to avoid filling up the **/audit** filesystem.

The audit undo rule must shut down audit and remove its enablement on reboot.

The following tables lists the values set by AIX Security Expert for **Enable binaudit**:

Table 17. Values set by AIX Security Expert for Enable binaudit

| High Level Security                                                                                                                                                                                                                                                                                                                                                                                                                                                                                                                                                                   | Medium Level Security                                                                                                                                                                                                                                                                                                                                                                                                                                                                   | Low Level Security                                                                                                                                                                                                                                                                                                                                                                                                                                   | AIX Standard Settings                                                                                                                                                                                                                       |
|---------------------------------------------------------------------------------------------------------------------------------------------------------------------------------------------------------------------------------------------------------------------------------------------------------------------------------------------------------------------------------------------------------------------------------------------------------------------------------------------------------------------------------------------------------------------------------------|-----------------------------------------------------------------------------------------------------------------------------------------------------------------------------------------------------------------------------------------------------------------------------------------------------------------------------------------------------------------------------------------------------------------------------------------------------------------------------------------|------------------------------------------------------------------------------------------------------------------------------------------------------------------------------------------------------------------------------------------------------------------------------------------------------------------------------------------------------------------------------------------------------------------------------------------------------|---------------------------------------------------------------------------------------------------------------------------------------------------------------------------------------------------------------------------------------------|
| <p>Add the following auditing entries for root and normal user:</p> <p>Root:</p> <ul style="list-style-type: none"> <li>General</li> <li>Src</li> <li>Mail</li> <li>Cron</li> <li>Tcpip</li> <li>Ipsec</li> <li>Lvm</li> </ul> <p>User:</p> <ul style="list-style-type: none"> <li>General</li> <li>Src</li> <li>Cron</li> <li>Tcpip</li> </ul> <p>Add the following entry in the user stanza of the <b>/usr/lib/security/mkuser.default</b> file for enabling auditing for newly created users:</p> <pre>auditclasses=general, SRC, cron, tcpip</pre>                                | <p>Add the following auditing entries for root and normal user:</p> <p>Root:</p> <ul style="list-style-type: none"> <li>General</li> <li>Src</li> <li>Tcpip</li> </ul> <p>User:</p> <ul style="list-style-type: none"> <li>General</li> <li>Tcpip</li> </ul> <p>Add the following entry in the user stanza of the <b>/usr/lib/security/mkuser.default</b> file for enabling auditing for newly created users:</p> <pre>auditclasses=general, tcpip</pre>                                | <p>Add the following auditing entries for root and normal user:</p> <p>Root:</p> <ul style="list-style-type: none"> <li>General</li> <li>Tcpip</li> </ul> <p>User:</p> <ul style="list-style-type: none"> <li>General</li> </ul> <p>Add the following entry in the user stanza of the <b>/usr/lib/security/mkuser.default</b> file for enabling auditing for newly created users:</p> <pre>auditclasses=general</pre>                                | <p>The <code>/etc/security/audit/</code> config file contains the following entry:</p> <pre>default=login</pre> <p>Audit class login is defined as follows:</p> <pre>login = USER_SU, USER_Login, USER_Logout, TERM_Logout, USER_Exit</pre> |
| <p>Add the following auditing entries for root and normal user:</p> <p><b>root:</b></p> <ul style="list-style-type: none"> <li>general</li> <li>src</li> <li>mail</li> <li>cron</li> <li>tcpip</li> <li>ipsec</li> <li>lvm</li> <li>aixpert</li> </ul> <p><i>User:</i></p> <ul style="list-style-type: none"> <li>general</li> <li>src</li> <li>cron</li> <li>tcpip</li> </ul> <p>Add the following entry in the user stanza of the <b>/usr/lib/security/mkuser.default</b> file for enabling auditing for newly created users:</p> <pre>auditclasses=general, SRC, cron, tcpip</pre> | <p>Add the following auditing entries for root and normal user:</p> <p><b>root:</b></p> <ul style="list-style-type: none"> <li>general</li> <li>src</li> <li>tcpip</li> <li>aixpert</li> </ul> <p><i>User:</i></p> <ul style="list-style-type: none"> <li>general</li> <li>tcpip</li> </ul> <p>Add the following entry in the user stanza of the <b>/usr/lib/security/mkuser.default</b> file for enabling auditing for newly created users:</p> <pre>auditclasses=general, tcpip</pre> | <p>Add the following auditing entries for root and normal user:</p> <p><b>root:</b></p> <ul style="list-style-type: none"> <li>general</li> <li>tcpip</li> <li>aixpert</li> </ul> <p><i>User:</i></p> <ul style="list-style-type: none"> <li>general</li> </ul> <p>Add the following entry in the user stanza of the <b>/usr/lib/security/mkuser.default</b> file for enabling auditing for newly created users:</p> <pre>auditclasses=general</pre> | <p>Yes</p>                                                                                                                                                                                                                                  |



The cronjob must run every hour and check the size of **/audit**. If the Audit Freespace Equation is true then the Audit Trail Copy Actions must be performed. The Audit Freespace Equation is defined to ensure that the **/audit** filesystem is not full; if the **/audit** filesystem is full, the Audit Trail Copy Actions are done (disabling auditing, taking backup of **/audit/trail** to **/audit/trailOneLevelBack**, and re-enabling auditing).

## AIX Security Expert **/etc/inittab** Entries group

AIX Security Expert comments out specific entries in **/etc/inittab** so that they do not start when the system boots.

Table 18. AIX Security Expert **/etc/inittab** Entries

| Action button name                                 | Description                                                                                                                                    | Value set by AIX Security Expert                                                                                                                                        | Undo |
|----------------------------------------------------|------------------------------------------------------------------------------------------------------------------------------------------------|-------------------------------------------------------------------------------------------------------------------------------------------------------------------------|------|
| Disable <b>qdaemon</b> /Enable <b>qdaemon</b>      | Comments out or uncomments the following entry in <b>/etc/inittab</b> :<br>qdaemon:2:wait:/usr/bin/startsrc -sqdaemon                          | <b>High Level Security</b><br>Comment<br><b>Medium Level Security</b><br>Comment<br><b>Low Level Security</b><br>No effect<br><b>AIX Standard Settings</b><br>Uncomment | Yes  |
| Disable <b>lpd</b> daemon/Enable <b>lpd</b> daemon | Comments out or uncomments the following entry in <b>/etc/inittab</b> :<br>lpd:2:once:/usr/bin/startsrc -s lpd                                 | <b>High Level Security</b><br>Comment<br><b>Medium Level Security</b><br>Comment<br><b>Low Level Security</b><br>No effect<br><b>AIX Standard Settings</b><br>Uncomment | Yes  |
| Disable CDE/Enable CDE                             | If the system does not have an LFT configured, comments out or uncomments the following entry in <b>/etc/inittab</b> :<br>dt:2:wait:/etc/rc.dt | <b>High Level Security</b><br>Comment<br><b>Medium Level Security</b><br>Comment<br><b>Low Level Security</b><br>No effect<br><b>AIX Standard Settings</b><br>Uncomment | Yes  |

Table 18. AIX Security Expert */etc/inittab* Entries (continued)

| Action button name                                     | Description                                                                                                                         | Value set by AIX Security Expert                                                                                                                                                    | Undo |
|--------------------------------------------------------|-------------------------------------------------------------------------------------------------------------------------------------|-------------------------------------------------------------------------------------------------------------------------------------------------------------------------------------|------|
| Disable <b>piobe</b> daemon/Enable <b>piobe</b> daemon | Comments out or uncomments the following entry in <i>/etc/inittab</i> :<br>piobe:2:wait:/usr/lib/lpd/pio/etc/pioint >/dev/null 2>&1 | <b>High Level Security</b><br>Comment<br><br><b>Medium Level Security</b><br>Comment<br><br><b>Low Level Security</b><br>No effect<br><br><b>AIX Standard Settings</b><br>Uncomment | Yes  |

## AIX Security Expert */etc/rc.tcpip* Settings group

AIX Security Expert comments out specific entries in */etc/rc.tcpip* so that they do not start when the system boots.

The following table lists entries that are commented out in */etc/rc.tcpip* so that they do not start when the system boots.

Table 19. AIX Security Expert */etc/rc.tcpip* Settings

| Action button name                     | Description                                                                                                           | Value set by AIX Security Expert                                                                                                                                                      | Undo |
|----------------------------------------|-----------------------------------------------------------------------------------------------------------------------|---------------------------------------------------------------------------------------------------------------------------------------------------------------------------------------|------|
| Disable mail client/Enable mail client | Comments out or uncomments the following entry from <i>/etc/rc.tcpip</i> :<br>start /usr/lib/sendmail "\$src_running" | <b>High Level Security</b><br>Comment<br><br><b>Medium Level Security</b><br>No effect<br><br><b>Low Level Security</b><br>No effect<br><br><b>AIX Standard Settings</b><br>Uncomment | Yes  |
| Disable routing daemon                 | Comments out the following entry from <i>/etc/rc.tcpip</i> :<br>start /usr/sbin/routed "\$src_running" -q             | <b>High Level Security</b><br>Yes<br><br><b>Medium Level Security</b><br>No effect<br><br><b>Low Level Security</b><br>No effect<br><br><b>AIX Standard Settings</b><br>Yes           | Yes  |

Table 19. AIX Security Expert */etc/rc.tcpip* Settings (continued)

| Action button name           | Description                                                                                            | Value set by AIX Security Expert                                                                                                                                            | Undo |
|------------------------------|--------------------------------------------------------------------------------------------------------|-----------------------------------------------------------------------------------------------------------------------------------------------------------------------------|------|
| Disable <b>mroued</b> daemon | Comments out the following entry from <i>/etc/rc.tcpip</i> :<br>start /usr/sbin/mroued "\$src_running" | <b>High Level Security</b><br>Yes<br><br><b>Medium Level Security</b><br>No effect<br><br><b>Low Level Security</b><br>No effect<br><br><b>AIX Standard Settings</b><br>Yes | Yes  |
| Disable <b>timed</b> daemon  | Comments out the following entry from <i>/etc/rc.tcpip</i> :<br>start /usr/sbin/timed                  | <b>High Level Security</b><br>Yes<br><br><b>Medium Level Security</b><br>Yes<br><br><b>Low Level Security</b><br>Yes<br><br><b>AIX Standard Settings</b><br>Yes             | Yes  |
| Disable <b>rwhod</b> daemon  | Comments out the following entry from <i>/etc/rc.tcpip</i> :<br>start /usr/sbin/rwhod "\$src_running"  | <b>High Level Security</b><br>Yes<br><br><b>Medium Level Security</b><br>No effect<br><br><b>Low Level Security</b><br>No effect<br><br><b>AIX Standard Settings</b><br>Yes | Yes  |
| Disable print daemon         | Comments out the following entry from <i>/etc/rc.tcpip</i> :<br>start /usr/sbin/lpd "\$src_running"    | <b>High Level Security</b><br>Yes<br><br><b>Medium Level Security</b><br>No effect<br><br><b>Low Level Security</b><br>No effect<br><br><b>AIX Standard Settings</b><br>Yes | Yes  |

Table 19. AIX Security Expert */etc/rc.tcpip* Settings (continued)

| Action button name                     | Description                                                                                                         | Value set by AIX Security Expert                                                                                                                                        | Undo |
|----------------------------------------|---------------------------------------------------------------------------------------------------------------------|-------------------------------------------------------------------------------------------------------------------------------------------------------------------------|------|
| Disable SNMP daemon/Enable SNMP daemon | Comments out or uncomments the following entry from <i>/etc/rc.tcpip</i> :<br>start /usr/sbin/snmpd "\$src_running" | <b>High Level Security</b><br>Comment<br><b>Medium Level Security</b><br>Comment<br><b>Low Level Security</b><br>No effect<br><b>AIX Standard Settings</b><br>Uncomment | Yes  |
| Stop DHCP Agent                        | Comments out the following entry from <i>/etc/rc.tcpip</i> :<br>start /usr/sbin/dhcprd "\$src_running"              | <b>High Level Security</b><br>Yes<br><b>Medium Level Security</b><br>Yes<br><b>Low Level Security</b><br>No effect<br><b>AIX Standard Settings</b><br>Yes               | Yes  |
| Stop DHCP Server                       | Comments out the following entry from <i>/etc/rc.tcpip</i> :<br>start /usr/sbin/dhcpsd "\$src_running"              | <b>High Level Security</b><br>Yes<br><b>Medium Level Security</b><br>Yes<br><b>Low Level Security</b><br>No effect<br><b>AIX Standard Settings</b><br>Yes               | Yes  |
| Stop autoconf6                         | Comments out the following entry from <i>/etc/rc.tcpip</i> :<br>start /usr/sbin/autoconf6 ""                        | <b>High Level Security</b><br>Yes<br><b>Medium Level Security</b><br>No effect<br><b>Low Level Security</b><br>No effect<br><b>AIX Standard Settings</b><br>Yes         | Yes  |

Table 19. AIX Security Expert */etc/rc.tcpip* Settings (continued)

| Action button name          | Description                                                                                           | Value set by AIX Security Expert                                                                                                                                            | Undo |
|-----------------------------|-------------------------------------------------------------------------------------------------------|-----------------------------------------------------------------------------------------------------------------------------------------------------------------------------|------|
| Disable DNS daemon          | Comments out the following entry from <i>/etc/rc.tcpip</i> :<br>start /usr/sbin/named "\$src_running" | <b>High Level Security</b><br>Yes<br><br><b>Medium Level Security</b><br>No effect<br><br><b>Low Level Security</b><br>No effect<br><br><b>AIX Standard Settings</b><br>Yes | Yes  |
| Disable <b>gated</b> daemon | Comments out the following entry from <i>/etc/rc.tcpip</i> :<br>start /usr/sbin/gated "\$src_running" | <b>High Level Security</b><br>Yes<br><br><b>Medium Level Security</b><br>Yes<br><br><b>Low Level Security</b><br>Yes<br><br><b>AIX Standard Settings</b><br>Yes             | Yes  |
| Stop DHCP Client            | Comments out the following entry from <i>/etc/rc.tcpip</i> :<br>start /usr/sbin/dhcpd "\$src_running" | <b>High Level Security</b><br>Yes<br><br><b>Medium Level Security</b><br>Yes<br><br><b>Low Level Security</b><br>No effect<br><br><b>AIX Standard Settings</b><br>Yes       | Yes  |
| Disable DPID2 daemon        | Comments out the following entry from <i>/etc/rc.tcpip</i> :<br>start /usr/sbin/dpid2 "\$src_running" | <b>High Level Security</b><br>Yes<br><br><b>Medium Level Security</b><br>No effect<br><br><b>Low Level Security</b><br>No effect<br><br><b>AIX Standard Settings</b><br>Yes | Yes  |

Table 19. AIX Security Expert */etc/rc.tcpip* Settings (continued)

| Action button name | Description                                                                                           | Value set by AIX Security Expert                                                                                                                                      | Undo |
|--------------------|-------------------------------------------------------------------------------------------------------|-----------------------------------------------------------------------------------------------------------------------------------------------------------------------|------|
| Disable NTP daemon | Comments out the following entry from <i>/etc/rc.tcpip</i> :<br>start /usr/sbin/xntpd "\$src_running" | <b>High Level Security</b><br>Yes<br><br><b>Medium Level Security</b><br>Yes<br><br><b>Low Level Security</b><br>No effect<br><br><b>AIX Standard Settings</b><br>Yes | Yes  |

## AIX Security Expert */etc/inetd.conf* Settings group

AIX Security Expert comments out specific entries in */etc/inetd.conf*.

Default installation of AIX enables a number of network services that can possibly compromise the security of the system. AIX Security Expert disables unnecessary and unsecure services by commenting out their respective entries from the */etc/inetd.conf* file. For AIX Standard Settings, these entries are uncommented. The following table lists entries that are commented out or uncommented in */etc/inetd.conf*.

Table 20. AIX Security Expert */etc/inetd.conf* Settings

| Action button name                                    | Description                                                                                                             | Value set by AIX Security Expert                                                                                                                                            | Undo |
|-------------------------------------------------------|-------------------------------------------------------------------------------------------------------------------------|-----------------------------------------------------------------------------------------------------------------------------------------------------------------------------|------|
| Disable <b>sprayd</b> in <i>/etc/inetd.conf</i>       | Comments out the following entry from <i>/etc/inetd.conf</i> :<br>sprayd sunrpc_udp udp wait root \<br>/usr/lib/netsvc/ | <b>High Level Security</b><br>Yes<br><br><b>Medium Level Security</b><br>Yes<br><br><b>Low Level Security</b><br>No effect<br><br><b>AIX Standard Settings</b><br>Yes       | Yes  |
| Disable UDP chargen service in <i>/etc/inetd.conf</i> | Comments out the following entry from <i>/etc/inetd.conf</i> :<br>chargen dgram udp wait root internal                  | <b>High Level Security</b><br>Yes<br><br><b>Medium Level Security</b><br>No effect<br><br><b>Low Level Security</b><br>No effect<br><br><b>AIX Standard Settings</b><br>Yes | Yes  |

Table 20. AIX Security Expert `/etc/inetd.conf` Settings (continued)

| Action button name                                                 | Description                                                                                                                                                     | Value set by AIX Security Expert                                                                                                                                          | Undo |
|--------------------------------------------------------------------|-----------------------------------------------------------------------------------------------------------------------------------------------------------------|---------------------------------------------------------------------------------------------------------------------------------------------------------------------------|------|
| Disable telnet /<br>Enable telnet                                  | Comments out or uncomments the following entry from <code>/etc/inetd.conf</code> :<br><pre>telnet stream tcp6 nowait root \<br/>/usr/sbin/telnetd telnetd</pre> | <b>High Level Security</b><br>Comment<br><b>Medium Level Security</b><br>No effect<br><b>Low Level Security</b><br>No effect<br><b>AIX Standard Settings</b><br>Uncomment | Yes  |
| Disable UDP<br>Echo service in<br><code>/etc/inetd.conf</code>     | Comments out the following entry from <code>/etc/inetd.conf</code> :<br><pre>echo dgram udp wait root internal</pre>                                            | <b>High Level Security</b><br>Yes<br><b>Medium Level Security</b><br>No effect<br><b>Low Level Security</b><br>No effect<br><b>AIX Standard Settings</b><br>Yes           | Yes  |
| Disable <code>tftpd</code> in<br><code>/etc/inetd.conf</code>      | Comments out the following entry from <code>/etc/inetd.conf</code> :<br><pre>tftpd dgram udp6 SRC nobody \<br/>/usr/sbin/tftpd tftpd -n</pre>                   | <b>High Level Security</b><br>Yes<br><b>Medium Level Security</b><br>Yes<br><b>Low Level Security</b><br>No effect<br><b>AIX Standard Settings</b><br>Yes                 | Yes  |
| Disable <code>krshd</code><br>daemon                               | Comments out the following entry from <code>/etc/inetd.conf</code> :<br><pre>kshell stream tcp nowait root \<br/>/usr/sbin/krshd krshd</pre>                    | <b>High Level Security</b><br>Yes<br><b>Medium Level Security</b><br>No effect<br><b>Low Level Security</b><br>No effect<br><b>AIX Standard Settings</b><br>Yes           | Yes  |
| Disable<br><code>rusersd</code> in<br><code>/etc/inetd.conf</code> | Comments out the following entry from <code>/etc/inetd.conf</code> :<br><pre>rusersd sunrpc_udp udp wait root \<br/>/usr/lib/netsvc/</pre>                      | <b>High Level Security</b><br>Yes<br><b>Medium Level Security</b><br>Yes<br><b>Low Level Security</b><br>No effect<br><b>AIX Standard Settings</b><br>Yes                 | Yes  |

Table 20. AIX Security Expert `/etc/inetd.conf` Settings (continued)

| Action button name                                                                               | Description                                                                                                                        | Value set by AIX Security Expert                                                                                                                                        | Undo |
|--------------------------------------------------------------------------------------------------|------------------------------------------------------------------------------------------------------------------------------------|-------------------------------------------------------------------------------------------------------------------------------------------------------------------------|------|
| Disable <b>rexecd</b> in <b>/etc/inetd.conf</b> / Enable <b>rexecd</b> in <b>/etc/inetd.conf</b> | Comments out the following entry from <b>/etc/inetd.conf</b> :<br>exec stream tcp6 nowait root \<br>/usr/sbin/rexecd rexecd        | <b>High Level Security</b><br>Comment<br><b>Medium Level Security</b><br>Comment<br><b>Low Level Security</b><br>No effect<br><b>AIX Standard Settings</b><br>Uncomment | Yes  |
| Disable POP3D                                                                                    | Comments out the following entry from <b>/etc/inetd.conf</b> :<br>pop3 stream tcp nowait root \<br>/usr/sbin/pop3d pop3d           | <b>High Level Security</b><br>Yes<br><b>Medium Level Security</b><br>No effect<br><b>Low Level Security</b><br>No effect<br><b>AIX Standard Settings</b><br>Yes         | Yes  |
| Disable <b>pcnfsd</b> in <b>/etc/inetd.conf</b>                                                  | Comments out the following entry from <b>/etc/inetd.conf</b> :<br>pcnfsd sunrpc_udp udp wait root \<br>/usr/sbin/rpc.pcnfsd pcnfsd | <b>High Level Security</b><br>Yes<br><b>Medium Level Security</b><br>No effect<br><b>Low Level Security</b><br>No effect<br><b>AIX Standard Settings</b><br>Yes         | Yes  |
| Disable <b>bootpd</b> in <b>/etc/inetd.conf</b>                                                  | Comments out the following entry from <b>/etc/inetd.conf</b> :<br>bootps dgram udp wait root \<br>/usr/sbin/bootpd                 | <b>High Level Security</b><br>Yes<br><b>Medium Level Security</b><br>Yes<br><b>Low Level Security</b><br>No effect<br><b>AIX Standard Settings</b><br>Yes               | Yes  |
| Disable <b>rwalld</b> in <b>/etc/inetd.conf</b>                                                  | Comments out the following entry from <b>/etc/inetd.conf</b> :<br>rwalld sunrpc_udp udp wait root \<br>/usr/lib/netstvc/           | <b>High Level Security</b><br>Yes<br><b>Medium Level Security</b><br>Yes<br><b>Low Level Security</b><br>No effect<br><b>AIX Standard Settings</b><br>Yes               | Yes  |



Table 20. AIX Security Expert `/etc/inetd.conf` Settings (continued)

| Action button name                                                                                                                   | Description                                                                                                                                       | Value set by AIX Security Expert                                                                                                                                          | Undo |
|--------------------------------------------------------------------------------------------------------------------------------------|---------------------------------------------------------------------------------------------------------------------------------------------------|---------------------------------------------------------------------------------------------------------------------------------------------------------------------------|------|
| Disable UDP discard service in <code>/etc/inetd.conf</code>                                                                          | Comments out the following entry from <code>/etc/inetd.conf</code> :<br>discard dgram udp wait root \<br>internal                                 | <b>High Level Security</b><br>Yes<br><b>Medium Level Security</b><br>No effect<br><b>Low Level Security</b><br>No effect<br><b>AIX Standard Settings</b><br>Yes           | Yes  |
| Disable TCP daytime service in <code>/etc/inetd.conf</code> / Enable TCP daytime service in <code>/etc/inetd.conf</code>             | Comments out or uncomments the following entry from <code>/etc/inetd.conf</code> :<br>daytime stream tcp nowait root \<br>internal                | <b>High Level Security</b><br>Comment<br><b>Medium Level Security</b><br>No effect<br><b>Low Level Security</b><br>No effect<br><b>AIX Standard Settings</b><br>Uncomment | Yes  |
| Disable <code>netstat</code> in <code>/etc/inetd.conf</code>                                                                         | Comments out the following entry from <code>/etc/inetd.conf</code> :<br>netstat stream tcp nowait nobody \<br>/usr/bin/netstat                    | <b>High Level Security</b><br>Yes<br><b>Medium Level Security</b><br>Yes<br><b>Low Level Security</b><br>No effect<br><b>AIX Standard Settings</b><br>Yes                 | Yes  |
| Disable <code>rshd</code> daemon/Enable <code>rshd</code> daemon                                                                     | Comments out or uncomments the following entry from <code>/etc/inetd.conf</code> :<br>shell stream tcp6 nowait root \<br>/usr/sbin/rshd rshd rshd | <b>High Level Security</b><br>Comment<br><b>Medium Level Security</b><br>Comment<br><b>Low Level Security</b><br>Comment<br><b>AIX Standard Settings</b><br>Uncomment     | Yes  |
| Disable <code>cmsd</code> service in <code>/etc/inetd.conf</code> / Enable <code>cmsd</code> service in <code>/etc/inetd.conf</code> | Comments out or uncomments the following entry from <code>/etc/inetd.conf</code> :<br>cmsd sunrpc_udp udp wait root \<br>/usr/dt/bin/rpc.cms cmsd | <b>High Level Security</b><br>Comment<br><b>Medium Level Security</b><br>No effect<br><b>Low Level Security</b><br>No effect<br><b>AIX Standard Settings</b><br>Uncomment | Yes  |

Table 20. AIX Security Expert `/etc/inetd.conf` Settings (continued)

| Action button name                                                                                                          | Description                                                                                                                                          | Value set by AIX Security Expert                                                                                                                                          | Undo |
|-----------------------------------------------------------------------------------------------------------------------------|------------------------------------------------------------------------------------------------------------------------------------------------------|---------------------------------------------------------------------------------------------------------------------------------------------------------------------------|------|
| Disable <b>ttdbserver</b> service in <b>/etc/inetd.conf</b><br>/ Enable <b>ttdbserver</b> service in <b>/etc/inetd.conf</b> | Comments out or uncomments the following entry from <b>/etc/inetd.conf</b> :<br><code>ttdbserver sunrpc_tcp tcp wait \<br/>root /usr/dt/bin/</code>  | <b>High Level Security</b><br>Comment<br><b>Medium Level Security</b><br>No effect<br><b>Low Level Security</b><br>No effect<br><b>AIX Standard Settings</b><br>Uncomment | Yes  |
| Disable <b>uucpd</b> in <b>/etc/inetd.conf</b><br>/ Enable <b>uucpd</b> in <b>/etc/inetd.conf</b>                           | Comments out or uncomments the following entry from <b>/etc/inetd.conf</b> :<br><code>uucp stream tcp nowait root \<br/>/usr/sbin/uucpd uucpd</code> | <b>High Level Security</b><br>Comment<br><b>Medium Level Security</b><br>No effect<br><b>Low Level Security</b><br>No effect<br><b>AIX Standard Settings</b><br>Uncomment | Yes  |
| Disable UDP time service in <b>/etc/inetd.conf</b><br>/ Enable UDP time service in <b>/etc/inetd.conf</b>                   | Comments out or uncomments the following entry from <b>/etc/inetd.conf</b> :<br><code>time dgram udp wait root internal</code>                       | <b>High Level Security</b><br>Comment<br><b>Medium Level Security</b><br>No effect<br><b>Low Level Security</b><br>No effect<br><b>AIX Standard Settings</b><br>Uncomment | Yes  |
| Disable TCP time service in <b>/etc/inetd.conf</b><br>/ Enable TCP time service in <b>/etc/inetd.conf</b>                   | Comments out or uncomments the following entry from <b>/etc/inetd.conf</b> :<br><code>time stream tcp nowait root \<br/>internal</code>              | <b>High Level Security</b><br>Comment<br><b>Medium Level Security</b><br>No effect<br><b>Low Level Security</b><br>No effect<br><b>AIX Standard Settings</b><br>Uncomment | Yes  |
| Disable <b>rexid</b> in <b>/etc/inetd.conf</b>                                                                              | Comments out the following entry from <b>/etc/inetd.conf</b> :<br><code>rexid sunrpc_tcp tcp wait root \<br/>/usr/sbin/tpc.rexid.rexid rexid</code>  | <b>High Level Security</b><br>Yes<br><b>Medium Level Security</b><br>Yes<br><b>Low Level Security</b><br>Yes<br><b>AIX Standard Settings</b><br>Yes                       | Yes  |

Table 20. AIX Security Expert `/etc/inetd.conf` Settings (continued)

| Action button name                                                                                                       | Description                                                                                                                                                | Value set by AIX Security Expert                                                                                                                                          | Undo |
|--------------------------------------------------------------------------------------------------------------------------|------------------------------------------------------------------------------------------------------------------------------------------------------------|---------------------------------------------------------------------------------------------------------------------------------------------------------------------------|------|
| Disable TCP chargen service in <code>/etc/inetd.conf</code>                                                              | Comments out the following entry from <code>/etc/inetd.conf</code> :<br><pre>chargen stream tcp nowait root \ internal</pre>                               | <b>High Level Security</b><br>Yes<br><b>Medium Level Security</b><br>No effect<br><b>Low Level Security</b><br>No effect<br><b>AIX Standard Settings</b><br>Yes           | Yes  |
| Disable <code>rlogin</code> in <code>/etc/inetd.conf</code> / Enable <code>rlogin</code> in <code>/etc/inetd.conf</code> | Comments out or uncomments the following entry from <code>/etc/inetd.conf</code> :<br><pre>login stream tcp6 nowait root \ /usr/sbin/rlogind rlogind</pre> | <b>High Level Security</b><br>Comment<br><b>Medium Level Security</b><br>Comment<br><b>Low Level Security</b><br>No effect<br><b>AIX Standard Settings</b><br>Uncomment   | Yes  |
| Disable talk in <code>/etc/inetd.conf</code>                                                                             | Comments out or uncomments the following entry from <code>/etc/inetd.conf</code> :<br><pre>talk dgram udp wait root \ /usr/sbin/talkd talkd</pre>          | <b>High Level Security</b><br>Comment<br><b>Medium Level Security</b><br>Comment<br><b>Low Level Security</b><br>Comment<br><b>AIX Standard Settings</b><br>Uncomment     | Yes  |
| Disable <code>fingerd</code> in <code>/etc/inetd.conf</code>                                                             | Comments out the following entry from <code>/etc/inetd.conf</code> :<br><pre>finger stream tcp nowait nobody \ /usr/sbin/fingerd fingerd</pre>             | <b>High Level Security</b><br>Yes<br><b>Medium Level Security</b><br>Yes<br><b>Low Level Security</b><br>No effect<br><b>AIX Standard Settings</b><br>Yes                 | Yes  |
| Disable FTP / Enable FTP                                                                                                 | Comments out or uncomments the following entry from <code>/etc/inetd.conf</code> :<br><pre>ftp stream tcp6 nowait root \ /usr/sbin/ftpd ftpd</pre>         | <b>High Level Security</b><br>Comment<br><b>Medium Level Security</b><br>No effect<br><b>Low Level Security</b><br>No effect<br><b>AIX Standard Settings</b><br>Uncomment | Yes  |

Table 20. AIX Security Expert `/etc/inetd.conf` Settings (continued)

| Action button name                                                                                                       | Description                                                                                                                            | Value set by AIX Security Expert                                                                                                                                          | Undo |
|--------------------------------------------------------------------------------------------------------------------------|----------------------------------------------------------------------------------------------------------------------------------------|---------------------------------------------------------------------------------------------------------------------------------------------------------------------------|------|
| Disable IMAPD                                                                                                            | Comments out the following entry from <code>/etc/inetd.conf</code> :<br>imap2 stream tcp nowait root \<br>/usr/sbin/imapd imapd        | <b>High Level Security</b><br>Yes<br><b>Medium Level Security</b><br>No effect<br><b>Low Level Security</b><br>No effect<br><b>AIX Standard Settings</b><br>Yes           | Yes  |
| Disable <b>comsat</b> in <code>/etc/inetd.conf</code>                                                                    | Comments out the following entry from <code>/etc/inetd.conf</code> :<br>comsat dgram udp wait root \<br>/usr/sbin/comsat comsat        | <b>High Level Security</b><br>Yes<br><b>Medium Level Security</b><br>No effect<br><b>Low Level Security</b><br>No effect<br><b>AIX Standard Settings</b><br>Yes           | Yes  |
| Disable <b>rquotad</b> in <code>/etc/inetd.conf</code>                                                                   | Comments out the following entry from <code>/etc/inetd.conf</code> :<br>rquotad sunrpc_udp udp wait root \<br>/usr/sbin/rpc.rquotad    | <b>High Level Security</b><br>Yes<br><b>Medium Level Security</b><br>Yes<br><b>Low Level Security</b><br>Yes<br><b>AIX Standard Settings</b><br>Yes                       | Yes  |
| Disable UDP daytime service in <code>/etc/inetd.conf</code> / Enable UDP daytime service in <code>/etc/inetd.conf</code> | Comments out or uncomments the following entry from <code>/etc/inetd.conf</code> :<br>daytime dgram udp wait root internal             | <b>High Level Security</b><br>Comment<br><b>Medium Level Security</b><br>No effect<br><b>Low Level Security</b><br>No effect<br><b>AIX Standard Settings</b><br>Uncomment | Yes  |
| Disable <b>krlogind</b> in <code>/etc/inetd.conf</code>                                                                  | Comments out the following entry from <code>/etc/inetd.conf</code> :<br>klogin stream tcp nowait root \<br>/usr/sbin/krlogind krlogind | <b>High Level Security</b><br>Yes<br><b>Medium Level Security</b><br>No effect<br><b>Low Level Security</b><br>No effect<br><b>AIX Standard Settings</b><br>Yes           | Yes  |

Table 20. AIX Security Expert `/etc/inetd.conf` Settings (continued)

| Action button name                                          | Description                                                                                                                              | Value set by AIX Security Expert                                                                                                                                | Undo |
|-------------------------------------------------------------|------------------------------------------------------------------------------------------------------------------------------------------|-----------------------------------------------------------------------------------------------------------------------------------------------------------------|------|
| Disable TCP Discard service in <code>/etc/inetd.conf</code> | Comments out the following entry from <code>/etc/inetd.conf</code> :<br>discard stream tcp nowait root \<br>internal                     | <b>High Level Security</b><br>Yes<br><b>Medium Level Security</b><br>No effect<br><b>Low Level Security</b><br>No effect<br><b>AIX Standard Settings</b><br>Yes | Yes  |
| Disable TCP echo service in <code>/etc/inetd.conf</code>    | Comments out the following entry from <code>/etc/inetd.conf</code> :<br>echo stream tcp nowait root internal                             | <b>High Level Security</b><br>Yes<br><b>Medium Level Security</b><br>No effect<br><b>Low Level Security</b><br>No effect<br><b>AIX Standard Settings</b><br>Yes | Yes  |
| Disable <b>sysstat</b> in <code>/etc/inetd.conf</code>      | Comments out the following entry from <code>/etc/inetd.conf</code> :<br>sysstat stream tcp nowait nodby \<br>/usr/bin/ps ps -ef          | <b>High Level Security</b><br>Yes<br><b>Medium Level Security</b><br>Yes<br><b>Low Level Security</b><br>No effect<br><b>AIX Standard Settings</b><br>Yes       | Yes  |
| Disable <b>rstatd</b> in <code>/etc/inetd.conf</code>       | Comments out the following entry from <code>/etc/inetd.conf</code> :<br>rstatd sunrpc_udp udp wait root \<br>/usr/sbin/rpc.rstatd rstatd | <b>High Level Security</b><br>Yes<br><b>Medium Level Security</b><br>Yes<br><b>Low Level Security</b><br>No effect<br><b>AIX Standard Settings</b><br>Yes       | Yes  |
| Disable dtspc in <code>/etc/inetd.conf</code>               | Comments out the following entry from <code>/etc/inetd.conf</code> :<br>dtspc stream tcp nowait root \<br>/usr/dt/bin/dtspcd             | <b>High Level Security</b><br>Yes<br><b>Medium Level Security</b><br>No effect<br><b>Low Level Security</b><br>No effect<br><b>AIX Standard Settings</b><br>Yes | Yes  |

## AIX Security Expert Disable SUID of Commands group

By default, the following commands are installed with the SUID bit set. For High, Medium, and Low security, this bit is unset. For AIX Standard Settings, the SUID bit is restored on these commands.

Table 21. AIX Security Expert Disable SUID of Commands

| Action button name | Description                                                                                                            | Value set by AIX Security Expert | Undo |
|--------------------|------------------------------------------------------------------------------------------------------------------------|----------------------------------|------|
| hls_filepermgr     | File Permissions Manager: Runs <b>fpm</b> command with high option to remove setuid, setgid from privileged commands   | High Level Security              | Yes  |
| mls_filepermgr     | File Permissions Manager: Runs <b>fpm</b> command with medium option to remove setuid, setgid from privileged commands | Medium Level Security            | Yes  |
| lls_filepermgr     | File Permissions Manager: Runs <b>fpm</b> command with low option to remove setuid, setgid from privileged commands    | Low Level Security               | Yes  |

## AIX Security Expert Disable Remote Services group

AIX Security Expert disables unsecure commands for High Level Security and Medium Level Security.

The following commands and daemons are exploited frequently for finding security loopholes. For High Level Security and Medium Level Security, these unsecure commands are denied execute permissions and the daemons are disabled. For Low Level Security, these commands and daemons are not affected. For AIX Standard Settings, these commands and daemons are enabled for use.

- **rcp**
- **rlogin**
- **rsh**
- **tftp**
- **rlogind**
- **rshd**
- **tftpd**

Table 22. AIX Security Expert Disable Remote Services

| Action button name      | Description                                                                                                                                                                                                                                                                                            | Value set by AIX Security Expert                                                                                                                                            | Undo |
|-------------------------|--------------------------------------------------------------------------------------------------------------------------------------------------------------------------------------------------------------------------------------------------------------------------------------------------------|-----------------------------------------------------------------------------------------------------------------------------------------------------------------------------|------|
| Enable unsecure daemons | If TCB is enabled, sets execute permissions of the <b>rlogind</b> , <b>rshd</b> , and <b>tftpd</b> daemons, updates the sysck database with the mode bit changes for these daemons. If TCB is not enabled, execute permissions on the <b>rlogind</b> , <b>rshd</b> , and <b>tftpd</b> daemons are set. | <b>High Level Security</b><br>No effect<br><b>Medium Level Security</b><br>No effect<br><b>Low Level Security</b><br>No effect<br><b>AIX Standard Settings</b><br>No effect | Yes  |

Table 22. AIX Security Expert Disable Remote Services (continued)

| Action button name       | Description                                                                                                                                                                                                                                                                                                                                                                                                                                                                                                                                                                                                                                                                                                         | Value set by AIX Security Expert                                                                                                                                                             | Undo |
|--------------------------|---------------------------------------------------------------------------------------------------------------------------------------------------------------------------------------------------------------------------------------------------------------------------------------------------------------------------------------------------------------------------------------------------------------------------------------------------------------------------------------------------------------------------------------------------------------------------------------------------------------------------------------------------------------------------------------------------------------------|----------------------------------------------------------------------------------------------------------------------------------------------------------------------------------------------|------|
| Disable secure commands  | <ol style="list-style-type: none"> <li>If TCB is enabled, removes the execute permissions of the <b>rcp</b>, <b>rlogin</b>, <b>rsh</b> commands and <b>tftp</b>, and updates the <b>sysck</b> database with the mode bit changes of these commands. If TCB is not enabled, removes the execute permissions on the <b>rcp</b>, <b>rlogin</b>, and <b>rsh</b> commands.</li> <li>Stops the current instances of <b>rcp</b>, <b>rlogin</b>, <b>rsh</b>, <b>tftp</b>, and <b>uftp</b> commands, unless one of these commands is the parent process of AIX Security Expert.</li> <li>Adds <b>tcpip:</b> stanza to <b>/etc/security/config</b> to restrict <b>.netrc</b> usage in <b>ftp</b> and <b>rexec</b>.</li> </ol> | <p><b>High Level Security</b><br/>Yes</p> <p><b>Medium Level Security</b><br/>No effect</p> <p><b>Low Level Security</b><br/>No effect</p> <p><b>AIX Standard Settings</b><br/>No effect</p> | Yes  |
| Enable unsecure commands | <ol style="list-style-type: none"> <li>If TCB is enabled, sets the execute permissions of the <b>rcp</b>, <b>rlogin</b>, <b>rsh</b>, and <b>tftp</b> commands and updates the <b>sysck</b> database with the mode bit changes of these commands. If TCB is not enabled, sets the execute permissions on the <b>rcp</b>, <b>rlogin</b>, and <b>rsh</b> commands.</li> <li>Removes the <b>/etc/security/config</b> file.</li> </ol>                                                                                                                                                                                                                                                                                   | <p><b>High Level Security</b><br/>No effect</p> <p><b>Medium Level Security</b><br/>No effect</p> <p><b>Low Level Security</b><br/>No effect</p> <p><b>AIX Standard Settings</b><br/>Yes</p> | Yes  |
| Disable unsecure daemons | <ol style="list-style-type: none"> <li>If TCB is enabled, removes execute permissions of the <b>rlogind</b>, <b>rshd</b>, and <b>tftpd</b> daemons and updates the <b>sysck</b> database with the mode bit changes of these daemons. If TCB is not enabled, removes the execute permissions of the <b>rlogind</b>, <b>rshd</b>, and <b>tftpd</b> daemons.</li> <li>Stops the current instances of the <b>rlogind</b>, <b>rshd</b>, and <b>tftpd</b> daemons, unless one of these daemons is the parent process of AIX Security Expert.</li> </ol>                                                                                                                                                                   | <p><b>High Level Security</b><br/>Yes</p> <p><b>Medium Level Security</b><br/>No effect</p> <p><b>Low Level Security</b><br/>No effect</p> <p><b>AIX Standard Settings</b><br/>No effect</p> | Yes  |
| Stop NFS daemon          | <ul style="list-style-type: none"> <li>Removes all NFS mounts</li> <li>Disables NFS</li> <li>Removes NFS startup script from <b>/etc/inittab</b></li> </ul>                                                                                                                                                                                                                                                                                                                                                                                                                                                                                                                                                         | <p><b>High Level Security</b><br/>Yes</p> <p><b>Medium Level Security</b><br/>No effect</p> <p><b>Low Level Security</b><br/>No effect</p> <p><b>AIX Standard Settings</b><br/>No effect</p> | Yes  |

Table 22. AIX Security Expert Disable Remote Services (continued)

| Action button name | Description                                                                                                                                                                                                                                | Value set by AIX Security Expert                                                                                                                                                             | Undo |
|--------------------|--------------------------------------------------------------------------------------------------------------------------------------------------------------------------------------------------------------------------------------------|----------------------------------------------------------------------------------------------------------------------------------------------------------------------------------------------|------|
| Enable NFS daemon  | <ul style="list-style-type: none"> <li>Exports all entries listed in <b>/etc/exports</b></li> <li>Adds an entry to <b>/etc/inittab</b> to run <b>/etc/rc.nfs</b> on system restart</li> <li>Runs <b>/etc/rc.nfs</b> immediately</li> </ul> | <p><b>High Level Security</b><br/>No effect</p> <p><b>Medium Level Security</b><br/>No effect</p> <p><b>Low Level Security</b><br/>No effect</p> <p><b>AIX Standard Settings</b><br/>Yes</p> | Yes  |

## AIX Security Expert Remove access that does not require Authentication group

AIX supports few services that do not require user authentication to log into the network.

The **/etc/hosts.equiv** file and any local **\$HOME/.rhosts** files define hosts and user accounts that can run remote commands on a local host without a password. Unless this capability is explicitly required, these files should be cleared.

Table 23. AIX Security Expert Remove access that does not require Authentication

| Action button name               | Description                                                                                                        | Value set by AIX Security Expert                                                                                                                                                                                                                                                                                                                                                                                                                                                                                                            | Undo |
|----------------------------------|--------------------------------------------------------------------------------------------------------------------|---------------------------------------------------------------------------------------------------------------------------------------------------------------------------------------------------------------------------------------------------------------------------------------------------------------------------------------------------------------------------------------------------------------------------------------------------------------------------------------------------------------------------------------------|------|
| Remove rhosts and netrc services | <b>.rhosts</b> and <b>.netrc</b> files store usernames and passwords in plain text format, which can be exploited. | <p><b>High Level Security</b><br/>Remove <b>.rhosts</b> and <b>.netrc</b> files from home directories of all users, including root.</p> <p><b>Medium Level Security</b><br/>Remove <b>.rhosts</b> and <b>.netrc</b> files from home directories of all users, including root.</p> <p><b>Low Level Security</b><br/>Remove <b>.rhosts</b> and <b>.netrc</b> files from home directory of root.</p> <p><b>AIX Standard Settings</b><br/>Remove <b>.rhosts</b> and <b>.netrc</b> files from home directories of all users, including root.</p> | Yes  |



Table 23. AIX Security Expert Remove access that does not require Authentication (continued)

| Action button name                               | Description                                                                                                                                                                                                                                                                                                                                                    | Value set by AIX Security Expert                                                                                                                                                                                                                                                                                                                        | Undo |
|--------------------------------------------------|----------------------------------------------------------------------------------------------------------------------------------------------------------------------------------------------------------------------------------------------------------------------------------------------------------------------------------------------------------------|---------------------------------------------------------------------------------------------------------------------------------------------------------------------------------------------------------------------------------------------------------------------------------------------------------------------------------------------------------|------|
| Remove entries from <b>/etc/hosts.equiv</b> file | The <b>/etc/hosts.equiv</b> file, along with a local user's <b>\$HOME/.rhosts</b> file, defines which users on foreign hosts are permitted to remotely run commands on the local host. If someone on the foreign host learns the details of the username and hostname, they can find ways to run remote commands on the local host without any authentication. | <b>High Level Security</b><br>Remove all entries from <b>/etc/hosts.equiv</b> .<br><br><b>Medium Level Security</b><br>Remove all entries from <b>/etc/hosts.equiv</b> .<br><br><b>Low Level Security</b><br>Remove all entries from <b>/etc/hosts.equiv</b> .<br><br><b>AIX Standard Settings</b><br>Remove all entries from <b>/etc/hosts.equiv</b> . | Yes  |

## AIX Security Expert Tuning Network Options group

Tuning network options to the proper values is a large part of security. Setting a network attribute to 0 disables the option and setting the network attribute to 1 enables the option.

The following table lists the network attribute settings for High, Medium, and Low Level Security. This table also provides a description of how the proposed value of any particular network option helps ensure the security of the network.

Table 24. AIX Security Expert Tuning Network Options for network security

| Action button name                      | Description                                                                                                                                            | Value set by AIX Security Expert                                                                                                                                               | Undo |
|-----------------------------------------|--------------------------------------------------------------------------------------------------------------------------------------------------------|--------------------------------------------------------------------------------------------------------------------------------------------------------------------------------|------|
| Network option <b>ipsrcrouteforward</b> | Specifies whether or not the system forwards source-routed packets. Disabling <b>ipsrcrouteforward</b> prevents access through source routing attacks. | <b>High Level Security</b><br>0<br><br><b>Medium Level Security</b><br>0<br><br><b>Low Level Security</b><br>No effect<br><br><b>AIX Standard Settings</b><br>1                | Yes  |
| Network option <b>ipignoreredirects</b> | Specifies whether or not to process received redirects.                                                                                                | <b>High Level Security</b><br>1<br><br><b>Medium Level Security</b><br>No effect<br><br><b>Low Level Security</b><br>No effect<br><br><b>AIX Standard Settings</b><br>No limit | Yes  |

Table 24. AIX Security Expert Tuning Network Options for network security (continued)

| Action button name                    | Description                                                                                                                                             | Value set by AIX Security Expert                                                                                                                                   | Undo |
|---------------------------------------|---------------------------------------------------------------------------------------------------------------------------------------------------------|--------------------------------------------------------------------------------------------------------------------------------------------------------------------|------|
| Network option<br>clean_partial_conns | Specifies whether or not to avoid synchronization character (SYN) attacks.                                                                              | <b>High Level Security</b><br>1<br><b>Medium Level Security</b><br>1<br><b>Low Level Security</b><br>1<br><b>AIX Standard Settings</b><br>No limit                 | Yes  |
| Network option<br>ipsrcrouterecv      | Specifies whether or not the system accepts source-routed packets. Disabling ipsrcrouterecv prevents access through source routing attacks.             | <b>High Level Security</b><br>0<br><b>Medium Level Security</b><br>No effect<br><b>Low Level Security</b><br>No effect<br><b>AIX Standard Settings</b><br>No limit | Yes  |
| Network option<br>ipforwarding        | Specifies whether or not the kernel should forward packets. Disabling ipforwarding prevents redirected packets from reaching a remote network.          | <b>High Level Security</b><br>0<br><b>Medium Level Security</b><br>No effect<br><b>Low Level Security</b><br>No effect<br><b>AIX Standard Settings</b><br>No limit | Yes  |
| Network option<br>ipsendredirects     | Specifies whether or not the kernel should send redirect signals. Disabling ipsendredirects prevents redirected packets from reaching a remote network. | <b>High Level Security</b><br>0<br><b>Medium Level Security</b><br>No effect<br><b>Low Level Security</b><br>No effect<br><b>AIX Standard Settings</b><br>1        | Yes  |
| Network option<br>ip6srcrouteforward  | Specifies whether or not the system forwards source-routed IPv6 packets. Disabling ip6srcrouteforward prevents access through source routing attacks.   | <b>High Level Security</b><br>0<br><b>Medium Level Security</b><br>No effect<br><b>Low Level Security</b><br>No effect<br><b>AIX Standard Settings</b><br>1        | Yes  |

Table 24. AIX Security Expert Tuning Network Options for network security (continued)

| Action button name                   | Description                                                                                                                                                       | Value set by AIX Security Expert                                                                                                                   | Undo |
|--------------------------------------|-------------------------------------------------------------------------------------------------------------------------------------------------------------------|----------------------------------------------------------------------------------------------------------------------------------------------------|------|
| Network option<br>directed_broadcast | Specifies whether or not to permit a directed broadcast to a gateway. Disabling directed_broadcast helps prevent directed packets from reaching a remote network. | <b>High Level Security</b><br>0<br><b>Medium Level Security</b><br>0<br><b>Low Level Security</b><br>0<br><b>AIX Standard Settings</b><br>No limit | Yes  |
| Network option<br>tcp_pmtu_discover  | Enables or disables path MTU discovery for TCP applications. Disabling tcp_pmtu_discover prevents access through source routing attacks.                          | <b>High Level Security</b><br>0<br><b>Medium Level Security</b><br>0<br><b>Low Level Security</b><br>0<br><b>AIX Standard Settings</b><br>1        | Yes  |
| Network option<br>bcastping          | Permits response to ICMP echo packets sent to the broadcast address. Disabling bcastping prevents smurf attacks.                                                  | <b>High Level Security</b><br>0<br><b>Medium Level Security</b><br>0<br><b>Low Level Security</b><br>0<br><b>AIX Standard Settings</b><br>No limit | Yes  |
| Network option<br>icmpaddressmask    | Specifies whether or not the system responds to an ICMP address mask request. Disabling icmpaddressmask prevents access through source routing attacks.           | <b>High Level Security</b><br>0<br><b>Medium Level Security</b><br>0<br><b>Low Level Security</b><br>0<br><b>AIX Standard Settings</b><br>No limit | Yes  |
| Network option<br>udp_pmtu_discover  | Enables or disables path maximum transfer unit (MTU) discovery for UDP applications. Disabling udp_pmtu_discover prevents access through source routing attacks.  | <b>High Level Security</b><br>0<br><b>Medium Level Security</b><br>0<br><b>Low Level Security</b><br>0<br><b>AIX Standard Settings</b><br>1        | Yes  |

Table 24. AIX Security Expert Tuning Network Options for network security (continued)

| Action button name               | Description                                                                                                                                                                                                                                                                                                                                                                               | Value set by AIX Security Expert                                                                                                                                   | Undo |
|----------------------------------|-------------------------------------------------------------------------------------------------------------------------------------------------------------------------------------------------------------------------------------------------------------------------------------------------------------------------------------------------------------------------------------------|--------------------------------------------------------------------------------------------------------------------------------------------------------------------|------|
| Network option<br>ipsrcroutesend | Specifies whether or not applications can send source-routed packets. Disabling ipsrcroutesend prevents access through source routing attacks.                                                                                                                                                                                                                                            | <b>High Level Security</b><br>0<br><b>Medium Level Security</b><br>No effect<br><b>Low Level Security</b><br>No effect<br><b>AIX Standard Settings</b><br>1        | Yes  |
| Network option<br>nonlocsrcroute | Specifies to the Internet Protocol whether or not strictly source-routed packets can be addressed to hosts outside the local network. Disabling nonlocsrcroute prevents access through source routing attacks.                                                                                                                                                                            | <b>High Level Security</b><br>0<br><b>Medium Level Security</b><br>No effect<br><b>Low Level Security</b><br>No effect<br><b>AIX Standard Settings</b><br>No limit | Yes  |
| Network option<br>tcp_tcpsecure  | Protects TCP connections against vulnerabilities.<br>Values: <ul style="list-style-type: none"> <li>• 0 = no protection</li> <li>• 1 = sending a fake SYN to an established connection</li> <li>• 2 = sending a fake RST to an established connection</li> <li>• 3 = injecting data in an established TCP connection</li> <li>• 5-7 = combination of the above vulnerabilities</li> </ul> | <b>High Level Security</b><br>7<br><b>Medium Level Security</b><br>7<br><b>Low Level Security</b><br>5<br><b>AIX Standard Settings</b><br>No limit                 | Yes  |
| Network option<br>sockthresh     | Specifies the network memory usage limit. No new socket connections are allowed to exceed the value of the sockthresh tunable.<br><br>Specifies the maximum amount of network memory that can be allocated for sockets.                                                                                                                                                                   | <b>High Level Security</b><br>60<br><b>Medium Level Security</b><br>70<br><b>Low Level Security</b><br>85<br><b>AIX Standard Settings</b><br>No limit              | Yes  |

The following network options are related to network performance rather than network security.

Table 25. AIX Security Expert Tuning Network Options for network performance

| Action button name              | Description                                                                                                                                          | Value set by AIX Security Expert                                                                                                                               | Undo |
|---------------------------------|------------------------------------------------------------------------------------------------------------------------------------------------------|----------------------------------------------------------------------------------------------------------------------------------------------------------------|------|
| Network option rfc1323          | The rfc1323 tunable enables the TCP window scaling option.                                                                                           | <b>High Level Security</b><br>1<br><b>Medium Level Security</b><br>1<br><b>Low Level Security</b><br>1<br><b>AIX Standard Settings</b><br>No limit             | Yes  |
| Network option tcp_sendspace    | The tcp_sendspace tunable specifies how much data the sending application can buffer in the kernel before the application is blocked on a send call. | <b>High Level Security</b><br>262144<br><b>Medium Level Security</b><br>262144<br><b>Low Level Security</b><br>262144<br><b>AIX Standard Settings</b><br>16384 | Yes  |
| Network option tcp_mssdfit      | Default maximum segment size used in communicating with remote networks.                                                                             | <b>High Level Security</b><br>1448<br><b>Medium Level Security</b><br>1448<br><b>Low Level Security</b><br>1448<br><b>AIX Standard Settings</b><br>1460        | Yes  |
| Network option extendednetstats | Enables more-extensive statistics for network memory services.                                                                                       | <b>High Level Security</b><br>1<br><b>Medium Level Security</b><br>1<br><b>Low Level Security</b><br>1<br><b>AIX Standard Settings</b><br>No limit             | Yes  |
| Network option tcp_recvspace    | The tcp_recvspace tunable specifies how many bytes of data the receiving system can buffer in the kernel on the receiving sockets queue.             | <b>High Level Security</b><br>262144<br><b>Medium Level Security</b><br>262144<br><b>Low Level Security</b><br>262144<br><b>AIX Standard Settings</b><br>16384 | Yes  |

Table 25. AIX Security Expert Tuning Network Options for network performance (continued)

| Action button name    | Description                                                                                                                                                                                                                        | Value set by AIX Security Expert                                                                                                                                    | Undo |
|-----------------------|------------------------------------------------------------------------------------------------------------------------------------------------------------------------------------------------------------------------------------|---------------------------------------------------------------------------------------------------------------------------------------------------------------------|------|
| Network option sb_max | The sb_max tunable sets an upper limit on the number of socket buffers queued to an individual socket, which controls how much buffer space is consumed by buffers that are queued to a sender's socket or to a receiver's socket. | <b>High Level Security</b><br>1048576<br><b>Medium Level Security</b><br>1048576<br><b>Low Level Security</b><br>1048576<br><b>AIX Standard Settings</b><br>1048576 | Yes  |

## AIX Security Expert IPsec filter rules group

AIX Security Expert provides the following IPsec filters.

Table 26. AIX Security Expert IPsec filter rules

| Action button name            | Description                                                                                                                                                                                             | Value set by AIX Security Expert                                                                                                                                      | Undo |
|-------------------------------|---------------------------------------------------------------------------------------------------------------------------------------------------------------------------------------------------------|-----------------------------------------------------------------------------------------------------------------------------------------------------------------------|------|
| Shun host for 5 minutes       | Shuns or blocks packets intended for several tcp and udp ports with known vulnerabilities on the host for five minutes. The host will not accept any packets destined for these ports for five minutes. | <b>High Level Security</b><br>Yes<br><b>Medium Level Security</b><br>No effect<br><b>Low Level Security</b><br>No effect<br><b>AIX Standard Settings</b><br>No effect | Yes  |
| Guard host against port scans | Guards against port scans. Any remote host performing a port scan is shunned or blocked for five minutes. All packets from this remote host are not accepted for five minutes.                          | <b>High Level Security</b><br>Yes<br><b>Medium Level Security</b><br>Yes<br><b>Low Level Security</b><br>No effect<br><b>AIX Standard Settings</b><br>No effect       | Yes  |

## AIX Security Expert Miscellaneous group

AIX Security Expert provides miscellaneous security settings for High, Medium, and Low Level Security.

Table 27. AIX Security Expert Miscellaneous group

| Action button name                      | Description                                                                                                                                                                                | Value set by AIX Security Expert                                                                                                                                                                                                                                                                                                               | Undo |
|-----------------------------------------|--------------------------------------------------------------------------------------------------------------------------------------------------------------------------------------------|------------------------------------------------------------------------------------------------------------------------------------------------------------------------------------------------------------------------------------------------------------------------------------------------------------------------------------------------|------|
| Remove dot from path root               | Check <b>\$HOME/.profile</b> , <b>\$HOME/.kshrc</b> , <b>\$HOME/.cshrc</b> , and <b>\$HOME/.login</b> files for "." in the <b>PATH</b> environment variable and remove it if it exists.    | <b>High Level Security</b><br>Yes<br><b>Medium Level Security</b><br>Yes<br><b>Low Level Security</b><br>Yes<br><b>AIX Standard Settings</b><br>Yes                                                                                                                                                                                            | Yes  |
| Limit system access                     | Ensures that root is the only user permitted to run <b>cron</b> jobs.                                                                                                                      | <b>High Level Security</b><br>Makes root the only user in the <b>cron.allow</b> file and removes the <b>cron.deny</b> file.<br><b>Medium Level Security</b><br>No effect<br><b>Low Level Security</b><br>No effect<br><b>AIX Standard Settings</b><br>Removes the <b>cron.allow</b> file and deletes all entries in the <b>cron.deny</b> file. | Yes  |
| Remove dot from <b>/etc/environment</b> | Removes "." from <b>PATH</b> environment variable in <b>/etc/environment</b> file.                                                                                                         | <b>High Level Security</b><br>Yes<br><b>Medium Level Security</b><br>Yes<br><b>Low Level Security</b><br>Yes<br><b>AIX Standard Settings</b><br>Yes                                                                                                                                                                                            | Yes  |
| Remove dot from non-root path           | Remove "." from the <b>PATH</b> environment variable from the <b>\$HOME/.profile</b> , <b>\$HOME/.kshrc</b> , <b>\$HOME/.cshrc</b> , and <b>\$HOME/.login</b> files of all non-root users. | <b>High Level Security</b><br>Yes<br><b>Medium Level Security</b><br>No effect<br><b>Low Level Security</b><br>No effect<br><b>AIX Standard Settings</b><br>No effect                                                                                                                                                                          | No   |

Table 27. AIX Security Expert Miscellaneous group (continued)

| Action button name                            | Description                                                                                                                                                                                                                                                                                                                                                                                                                                                                                                                                                                                                                                  | Value set by AIX Security Expert                                                                                                                                                                                                                                                                                                            | Undo |
|-----------------------------------------------|----------------------------------------------------------------------------------------------------------------------------------------------------------------------------------------------------------------------------------------------------------------------------------------------------------------------------------------------------------------------------------------------------------------------------------------------------------------------------------------------------------------------------------------------------------------------------------------------------------------------------------------------|---------------------------------------------------------------------------------------------------------------------------------------------------------------------------------------------------------------------------------------------------------------------------------------------------------------------------------------------|------|
| Add root user in <b>/etc/ftpusers</b> file    | Add root user name to <b>/etc/ftpusers</b> file to disable remote root <b>ftp</b> .                                                                                                                                                                                                                                                                                                                                                                                                                                                                                                                                                          | <b>High Level Security</b><br>Yes<br><b>Medium Level Security</b><br>Yes<br><b>Low Level Security</b><br>No effect<br><b>AIX Standard Settings</b><br>Yes                                                                                                                                                                                   | Yes  |
| Remove root user in <b>/etc/ftpusers</b> file | Remove root entry from <b>/etc/ftpusers</b> to enable remote root <b>ftp</b> .                                                                                                                                                                                                                                                                                                                                                                                                                                                                                                                                                               | <b>High Level Security</b><br>No effect<br><b>Medium Level Security</b><br>No effect<br><b>Low Level Security</b><br>No effect<br><b>AIX Standard Settings</b><br>Yes                                                                                                                                                                       | Yes  |
| Set login herald                              | Checks <b>/etc/security/login.cfg</b> to ensure that a herald value is not specified. If the default herald is being used, the herald should be changed. The herald can be changed only if the system's locale is <b>en_US</b> or another English locale. If this criteria is met, the herald attribute's value in the default stanza of <b>/etc/security/login.cfg</b> file is set to the following:<br><br>Unauthorized use of this \ system is prohibited.\nlogin:<br><br><b>Note:</b> The security setting takes effect only for new sessions. The security setting does not take effect in the session where the configuration was set. | <b>High Level Security</b><br>herald="Unauthorized use of this system is prohibited.\nlogin:"<br><b>Medium Level Security</b><br>herald="Unauthorized use of this system is prohibited.\nlogin:"<br><b>Low Level Security</b><br>herald="Unauthorized use of this system is prohibited.\nlogin:"<br><b>AIX Standard Settings</b><br>herald= | Yes  |
| Remove guest account                          | For High, Medium, and Low security, removes the guest account as well as guest's data on the machine. For AIX Standard Settings, the guest account is created on the system.<br><b>Note:</b> A system administrator must set the password for this account explicitly, as AIX Security Expert is not designed to handle such user interactive tasks.                                                                                                                                                                                                                                                                                         | <b>High Level Security</b><br>Remove guest account and data<br><b>Medium Level Security</b><br>Remove guest account and data<br><b>Low Level Security</b><br>Remove guest account and data<br><b>AIX Standard Settings</b><br>Adds the guest account on the machine.                                                                        | Yes  |



Table 27. AIX Security Expert Miscellaneous group (continued)

| Action button name          | Description                                                                                                                                                                                                                                                                                      | Value set by AIX Security Expert                                                                                                                                                                         | Undo |
|-----------------------------|--------------------------------------------------------------------------------------------------------------------------------------------------------------------------------------------------------------------------------------------------------------------------------------------------|----------------------------------------------------------------------------------------------------------------------------------------------------------------------------------------------------------|------|
| Crontab permissions         | Ensures that root's <b>crontab</b> jobs are owned and writeable only by root.                                                                                                                                                                                                                    | <b>High Level Security</b><br>Yes<br><b>Medium Level Security</b><br>Yes<br><b>Low Level Security</b><br>Yes<br><b>AIX Standard Settings</b><br>No effect                                                | Yes  |
| Enable X-Server access      | Mandates authentication for access to the X-Server.                                                                                                                                                                                                                                              | <b>High Level Security</b><br>Authentication required<br><b>Medium Level Security</b><br>Authentication required<br><b>Low Level Security</b><br>No effect<br><b>AIX Standard Settings</b><br>Not needed | No   |
| Object creation permissions | Sets appropriate value to <b>umask</b> attribute of <b>/etc/security/user</b> , which specifies default object creation permissions.                                                                                                                                                             | <b>High Level Security</b><br>077<br><b>Medium Level Security</b><br>027<br><b>Low Level Security</b><br>No effect<br><b>AIX Standard Settings</b><br>022                                                | Yes  |
| Set core file size          | Sets appropriate value to <b>core</b> attribute of <b>/etc/security/limits</b> , which specifies the core file size for root.<br><b>Note:</b> The security setting takes effect only for new sessions. The security setting does not take effect in the session where the configuration was set. | <b>High Level Security</b><br>0<br><b>Medium Level Security</b><br>0<br><b>Low Level Security</b><br>0<br><b>AIX Standard Settings</b><br>2097151                                                        | Yes  |
| Enable SED feature          | Enables the Stack Execution Disable feature and runs the <b>sedmgr</b> command on the files specified.<br><b>Note:</b> System reboot is needed for the rule to take affect.                                                                                                                      | <b>High Level Security</b><br>setidfiles<br><b>Medium Level Security</b><br>No effect<br><b>Low Level Security</b><br>No effect<br><b>AIX Standard Settings</b><br>No effect                             |      |

Table 27. AIX Security Expert Miscellaneous group (continued)

| Action button name            | Description                                                                                                                                                                                                                      | Value set by AIX Security Expert                                                                                                                                | Undo |
|-------------------------------|----------------------------------------------------------------------------------------------------------------------------------------------------------------------------------------------------------------------------------|-----------------------------------------------------------------------------------------------------------------------------------------------------------------|------|
| Root Password Integrity Check | Ensures that the root password is not weak. The dictionlist attribute of root is set to <b>/etc/security/aixpert/dictionary/English</b> , so that <b>passwd</b> command can ensure that the root password being set is not weak. | <b>High Level Security</b><br>Yes<br><b>Medium Level Security</b><br>Yes<br><b>Low Level Security</b><br>No effect<br><b>AIX Standard Settings</b><br>No effect | Yes  |

## AIX Security Expert Undo Security

You can undo some AIX Security Expert security settings and rules.

The following AIX Security Expert security settings and rules cannot be undone.

Table 28. AIX Security Expert non-reversible security settings and rules

|                                                                                                   |                                                                                               |
|---------------------------------------------------------------------------------------------------|-----------------------------------------------------------------------------------------------|
| Check password definitions for High Level Security, Medium Level Security, and Low Level Security | Enable X-Server access for High Level Security, Medium Level Security, and Low Level Security |
| Check user definitions for High Level Security, Medium Level Security, and Low Level Security     | Remove dot from non-root path for High Level Security and AIX Standard Settings               |
| Check group definitions for High Level Security, Medium Level Security, and Low Level Security    | Remove guest account for High Level Security, Medium Level Security, and Low Level Security   |
| TCB update for High Level Security, Medium Level Security, and Low Level Security                 |                                                                                               |

## AIX Security Expert Check Security

AIX Security Expert can generate reports of current system and network security settings.

After AIX Security Expert is used to configure a system, the Check Security option can be used to report the various configuration settings. If any of these settings have been changed outside the control of AIX Security Expert, the AIX Security Expert Check Security option logs these differences in the **/etc/security/aixpert/check\_report.txt** file.

For example, the **talkd** daemon is disabled in **/etc/inetd.conf** when you apply Low Level Security. If the **talkd** daemon is later enabled and then Check Security is run, this information will be logged in the **check\_report.txt** file as follows:

```
coninetdconf.ksh: Service talk using protocol udp should be disabled, however it is enabled now.
```

If the applied security settings have not been changed, the **check\_report.txt** file will be empty.

The Check Security option should be run periodically and the resulting report should be reviewed to see if any settings have been changed since AIX Security Expert security settings were applied. The Check Security option should also be run as part of any major system change such as the installation or updating of software.

## AIX Security Expert files

AIX Security Expert creates and uses several files.

**/etc/security/aixpert/core/aixpertall.xml**

Contains an XML listing of all possible security settings.

**/etc/security/aixpert/core/appliedaixpert.xml**

Contains an XML list of applied security settings.

**/etc/security/aixpert/core/secaixpert.xml**

Contains an XML listing of selected security settings when processed by the AIX Security Expert GUI.

**/etc/security/aixpert/log/aixpert.log**

Contains a trace log of applied security settings. AIX Security Expert does not use syslog; AIX Security Expert writes directly to **/etc/security/aixpert/log/aixpert.log**.

**Note:** The AIX Security Expert XML and log files are created with the following permissions:

**/etc/security/aixpert/**

drwx-----

**/etc/security/aixpert/core/**

drwx-----

**/etc/security/aixpert/core/aixpertall.xml**

r-----

**/etc/security/aixpert/core/appliedaixpert.xml**

**/etc/security/aixpert/core/secaixpert.xml**

**/etc/security/aixpert/log**

drwx-----

**/etc/security/aixpert/log/aixpert.log**

-rw-----

**/etc/security/aixpert/core/secundoaixpert.xml**

rw-----

**/etc/security/aixpert/check\_report.txt**

rw-----

## AIX Security Expert High level security scenario

This is a scenario for AIX Security Expert High level security.

The AIX Security Expert view of security levels is derived in part from the National Institute of Standards and Technology document *Security Configuration Checklists Program for IT Products - Guidance for CheckLists Users and Developers* ([http://csrc.nist.gov/checklists/download\\_sp800-70.html](http://csrc.nist.gov/checklists/download_sp800-70.html)). However, High, Medium, and Low level security mean different things to different people. It is important to understand the environment in which your system operates. If you chose a security level that too high, you could lock yourself out of your computer. If you chose a security level that is too low, your computer might be vulnerable to a cyber attack.

This is an example of an environment that requires High Level Security. Bob will be colocating his system with an Internet service provider. The system will be connected directly to the Internet, will run as a HTTP server, will contain sensitive user data, and needs to be administered remotely by Bob. The system should be set up and tested on an isolated local network before the system is put online with the ISP.

High level security is the correct security level for this environment, but Bob needs remote access to the system. High level security does not permit **telnet**, **rlogin**, **ftp**, and other common connections that transmit passwords over the network in the clear. These passwords can easily be snooped by someone on the Internet. Bob needs a secure method to log in remotely, such as **openssh**. Bob can read the complete

AIX Security Expert documentation to see if there is anything unique to his environment that might be inhibited by High level security. If so, he can deselect this when the detailed High level security panel is displayed. Bob should also configure and start the HTTP server or any other services he intends to offer on his system.

When Bob then selects High level security, AIX Security Expert will recognize that the running services are required and will not block access to their ports. Access to all other ports could be a vulnerability and High level security will block these ports. After testing this configuration, Bob's machine is now ready to go live on the Internet.

## AIX Security Expert Medium level security scenario

This is a scenario for AIX Security Expert Medium level security.

Alice needs to security harden a system that will be connected to the corporate network, which resides behind the corporate firewall. The network is secure and well-administered. This system will be used by a large number of users who need to access the system **telnet** and **ftp**. Alice wants the common security settings in place, such as port scan protection and password expirations, but the system must also be open to most remote access methods. In this scenario, Medium level security is the most appropriate security setting for Alice's system.

## AIX Security Expert Low level security scenario

This is a scenario for AIX Security Expert Low level security.

Bruce has been administering a system for some time. The system resides on an isolated secure local network. This system is used for a wide variety of people and services. He wants to bring the system up from the minimal level of security, but cannot interrupt any form of access to the system. Low level security is the correct security level for Bruce's machine.

---

## Security checklist

The following is a checklist of security actions to perform on a newly installed or existing system.

Although this list is not a complete security checklist, it can be used as a foundation to build a security checklist for your environment.

- When installing a new system, install AIX from secure base media. Perform the following procedures at installation time:
  - Do not install desktop software, such as CDE, GNOME, or KDE, on servers.
  - Install required security fixes and any recommended maintenance and technology level fixes. See the IBM System p eServer Support Fixes website (<http://www-03.ibm.com/servers/eserver/support/unixservers/aixfixes.html>) for the newest service bulletins, security advisories, and fix information.
  - Back up the system after the initial installation and store the system backup in a secure location.
- Establish access control lists for restricted files and directories.
- Disable unnecessary user accounts and system accounts, such as daemon, bin, sys, adm, lp, and uucp. Deleting accounts is not recommended because it deletes account information, such as user IDs and user names, which may still be associated with data on system backups. If a user is created with a previously deleted user ID and the system backup is restored on the system, the new user might have unexpected access to the restored system.
- Review the **/etc/inetd.conf**, **/etc/inittab**, **/etc/rc.nfs**, and **/etc/rc.tcpip** files on a regular basis and remove all unnecessary daemons and services.
- Verify that the permissions for the following files are set correctly:
  - rw-rw-r-- root system /etc/filesystems
  - rw-rw-r-- root system /etc/hosts
  - rw----- root system /etc/inittab

```
-rw-r--r-- root system /etc/vfs
-rw-r--r-- root system /etc/security/failedlogin
-rw-rw---- root audit /etc/security/audit/hosts
```

- Disable the root account from being able to remotely log in. The root account should be able to log in only from the system console.
- Enable system auditing. For more information, see “Auditing overview” on page 119.
- Enable a login control policy. For more information, see “Login control” on page 32.
- Disable user permissions to run the **xhost** command. For more information, see “Managing X11 and CDE concerns” on page 38.
- Prevent unauthorized changes to the **PATH** environment variable. For more information, see “PATH environment variable” on page 52.
- Disable telnet, rlogin, and rsh. For more information, see “TCP/IP security” on page 199.
- Establish user account controls. For more information, see “User account control” on page 50.
- Enforce a strict password policy. For more information, see “Passwords” on page 58.
- Establish disk quotas for user accounts. For more information, see “Recovering from over-quota conditions” on page 70.
- Allow only administrative accounts to use the **su** command. Monitor the **su** command’s logs in the **/var/adm/sulog** file.
- Enable screen locking when using X-Windows.
- Restrict access to the **cron** and **at** commands to only the accounts that need access to them.
- Use an alias for the **ls** command to show hidden files and characters in a file name.
- Use an alias for the **rm** command to avoid accidentally deleting files from the system.
- Disable unnecessary network services. For more information, see “Network services” on page 207.
- Perform frequent system backups and verify the integrity of backups.
- Subscribe to security-related e-mail distribution lists.

---

## Security resources

This section provides information on various security-related resources such as Web sites, mailing lists and online references.

### Security Web sites

AIX Virtual Private Networks: <http://www-1.ibm.com/servers/aix/products/ibmsw/security/vpn/index.html>)

CERIAS (Center for Education and Research in Information Assurance and Security):  
<http://www.cerias.purdue.edu/>

CERT (Computer Emergency Response Team, at Carnegie Mellon University): <http://www.cert.org/>

CIAC (Computer Incident Advisory Capability): <http://ciac.llnl.gov/ciac/index.html>

Computer Security Resource Clearinghouse: <http://csrc.ncsl.nist.gov/>

FIRST (Forum of Incident Response and Security Teams): <http://www.first.org/>

IBM eServer Security Planner: [http://publib.boulder.ibm.com/infocenter/eserver/v1r1/en\\_US/index.htm?info/secplanr/securwiz.htm](http://publib.boulder.ibm.com/infocenter/eserver/v1r1/en_US/index.htm?info/secplanr/securwiz.htm)

IBM Security Solutions: <http://www-3.ibm.com/security/index.shtml>

OpenSSH: <http://www.openssh.org/>

IBM System p Security home page: <http://www-1.ibm.com/servers/eserver/pseries/security/>

## Security mailing lists

CERT: [http://www.cert.org/contact\\_cert/](http://www.cert.org/contact_cert/)

IBM System p eServer Support Subscription Service: <http://www14.software.ibm.com/webapp/set2/subscriptions/pqvcmjtd>

comp.security.unix: news:comp.security.unix

## Security online references

faqs.org: <http://www.faqs.org/faqs/computer-security/>

IBM AIX Information Center: <http://publib16.boulder.ibm.com/pseries/index.htm>

---

## Summary of common AIX system services

The following table lists the more common system services within AIX. Use this table to recognize a starting point for securing your system.

Before you secure your system, back up all your original configuration files, especially the following:

- **/etc/inetd.conf**
- **/etc/inittab**
- **/etc/rc.nfs**
- **/etc/rc.tcpip**

| Service       | Daemon | Started by      | Function                           | Comments                                                                                                                                                                                                   |
|---------------|--------|-----------------|------------------------------------|------------------------------------------------------------------------------------------------------------------------------------------------------------------------------------------------------------|
| inetd/bootps  | inetd  | /etc/inetd.conf | bootp services to diskless clients | <ul style="list-style-type: none"><li>• Necessary for Network Installation Management (NIM) and remote booting of systems</li><li>• Works concurrently with tftp</li><li>• Disable in most cases</li></ul> |
| inetd/chargen | inetd  | /etc/inetd.conf | character generator (testing only) | <ul style="list-style-type: none"><li>• Available as a TCP and UDP service</li><li>• Provides opportunity for Denial of Service attacks</li><li>• Disable unless you are testing your network</li></ul>    |
| inetd/cmsd    | inetd  | /etc/inetd.conf | calendar service (as used by CDE)  | <ul style="list-style-type: none"><li>• Runs as root, therefore a security concern</li><li>• Disable unless you require this service with CDE</li><li>• Disable on back room database servers</li></ul>    |
| inetd/comsat  | inetd  | /etc/inetd.conf | Notifies incoming electronic mail  | <ul style="list-style-type: none"><li>• Runs as root, therefore a security concern</li><li>• Seldom required</li><li>• Disable</li></ul>                                                                   |

| Service       | Daemon | Started by      | Function                             | Comments                                                                                                                                                                                                                                                                                                                                                                                                    |
|---------------|--------|-----------------|--------------------------------------|-------------------------------------------------------------------------------------------------------------------------------------------------------------------------------------------------------------------------------------------------------------------------------------------------------------------------------------------------------------------------------------------------------------|
| inetd/daytime | inetd  | /etc/inetd.conf | obsolete time service (testing only) | <ul style="list-style-type: none"> <li>• Runs as root</li> <li>• Available as a TCP and UDP service</li> <li>• Provides opportunity for a Denial of Service PING attacks</li> <li>• Service is obsolete and used for testing only</li> <li>• Disable</li> </ul>                                                                                                                                             |
| inetd/discard | inetd  | /etc/inetd.conf | /dev/null service (testing only)     | <ul style="list-style-type: none"> <li>• Available as TCP and UDP service</li> <li>• Used in Denial of Service Attacks</li> <li>• Service is obsolete and used for testing only</li> <li>• Disable</li> </ul>                                                                                                                                                                                               |
| inetd/dtspc   | inetd  | /etc/inetd.conf | CDE Subprocess Control               | <ul style="list-style-type: none"> <li>• This service is started automatically by the <b>inetd</b> daemon in response to a CDE client requesting a process to be started on the daemon's host. This makes it vulnerable to attacks</li> <li>• Disable on back room servers with no CDE</li> <li>• CDE might be able to function without this service</li> <li>• Disable unless absolutely needed</li> </ul> |
| inetd/echo    | inetd  | etc/inetd.conf  | echo service (testing only)          | <ul style="list-style-type: none"> <li>• Available as UDP and TCP service</li> <li>• Could be used in Denial of Service or Smurf attacks</li> <li>• Used to echo at someone else to get through a firewall or start a datastorm</li> <li>• Disable</li> </ul>                                                                                                                                               |
| inetd/exec    | inetd  | /etc/inetd.conf | remote execution service             | <ul style="list-style-type: none"> <li>• Runs as root user</li> <li>• Requires that you enter a user ID and password, which are passed unprotected</li> <li>• This service is highly susceptible to being snooped</li> <li>• Disable</li> </ul>                                                                                                                                                             |
| inetd/finger  | inetd  | /etc/inetd.conf | finger peeking at users              | <ul style="list-style-type: none"> <li>• Runs as root user</li> <li>• Gives out information about your systems and users</li> <li>• Disable</li> </ul>                                                                                                                                                                                                                                                      |

| Service       | Daemon | Started by      | Function                             | Comments                                                                                                                                                                                                                                                 |
|---------------|--------|-----------------|--------------------------------------|----------------------------------------------------------------------------------------------------------------------------------------------------------------------------------------------------------------------------------------------------------|
| inetd/ftp     | inetd  | /etc/inetd.conf | file transfer protocol               | <ul style="list-style-type: none"> <li>• Runs as root user</li> <li>• User id and password are transferred unprotected, thus allowing them to be snooped</li> <li>• Disable this service and use a public domain secure shell suite</li> </ul>           |
| inetd/imap2   | inetd  | /etc/inetd.conf | Internet Mail Access Protocol        | <ul style="list-style-type: none"> <li>• Ensure that you are using the latest version of this server</li> <li>• Only necessary if you are running a mail server. Otherwise, disable</li> <li>• User ID and password are passed unprotected</li> </ul>    |
| inetd/klogin  | inetd  | /etc/inetd.conf | Kerberos login                       | <ul style="list-style-type: none"> <li>• Enabled if your site uses Kerberos authentication</li> </ul>                                                                                                                                                    |
| inetd/kshell  | inetd  | /etc/inetd.conf | Kerberos shell                       | <ul style="list-style-type: none"> <li>• Enabled if your site uses Kerberos authentication</li> </ul>                                                                                                                                                    |
| inetd/login   | inetd  | /etc/inetd.conf | rlogin service                       | <ul style="list-style-type: none"> <li>• Susceptible to IP spoofing, DNS spoofing</li> <li>• Data, including User IDs and passwords, is passed unprotected</li> <li>• Runs as root user</li> <li>• Use a secure shell instead of this service</li> </ul> |
| inetd/netstat | inetd  | /etc/inetd.conf | reporting of current network status  | <ul style="list-style-type: none"> <li>• Could potentially give network information to hackers if run on your system</li> <li>• Disable</li> </ul>                                                                                                       |
| inetd/ntalk   | inetd  | /etc/inetd.conf | Allows users to talk with each other | <ul style="list-style-type: none"> <li>• Runs as root user</li> <li>• Not required on production or back room servers</li> <li>• Disable unless absolutely needed</li> </ul>                                                                             |
| inetd/pcnfsd  | inetd  | /etc/inetd.conf | PC NFS file services                 | <ul style="list-style-type: none"> <li>• Disable service if not currently in use</li> <li>• If you need a service similar to this, consider Samba, as the pcnfsd daemon predates Microsoft's release of SMB specifications</li> </ul>                    |



| Service       | Daemon | Started by      | Function                                 | Comments                                                                                                                                                                                                                                                                                                                                                                                                                                                         |
|---------------|--------|-----------------|------------------------------------------|------------------------------------------------------------------------------------------------------------------------------------------------------------------------------------------------------------------------------------------------------------------------------------------------------------------------------------------------------------------------------------------------------------------------------------------------------------------|
| inetd/pop3    | inetd  | /etc/inetd.conf | Post Office Protocol                     | <ul style="list-style-type: none"> <li>• User IDs and passwords are sent unprotected</li> <li>• Only needed if your system is a mail server and you have clients who are using applications that only support POP3</li> <li>• If your clients use IMAP, use that instead, or use the POP3s service. This service has a Secure Socket Layer (SSL) tunnel</li> <li>• Disable if you are not running a mail server or have clients who need POP services</li> </ul> |
| inetd/rexd    | inetd  | /etc/inetd.conf | remote execution                         | <ul style="list-style-type: none"> <li>• Runs as root user</li> <li>• Peers with the <b>on</b> command</li> <li>• Disable service</li> <li>• Use <b>rshand rshd</b> instead</li> </ul>                                                                                                                                                                                                                                                                           |
| inetd/quotad  | inetd  | /etc/inetd.conf | reports of file quotas (for NFS clients) | <ul style="list-style-type: none"> <li>• Only needed if you are running NFS file services</li> <li>• Disable this service unless required to provide an answer for the <b>quota</b> command</li> <li>• If you need to use this service, keep all patches and fixes for this service up to date</li> </ul>                                                                                                                                                        |
| inetd/rstatd  | inetd  | /etc/inetd.conf | Kernel Statistics Server                 | <ul style="list-style-type: none"> <li>• If you need to monitor systems, use SNMP and disable this service</li> <li>• Required for use of the <b>rup</b> command</li> </ul>                                                                                                                                                                                                                                                                                      |
| inetd/rusersd | inetd  | /etc/inetd.conf | info about user logged in                | <ul style="list-style-type: none"> <li>• This is not an essential service. Disable</li> <li>• Runs as root user</li> <li>• Gives out a list of current users on your system and peers with rusers</li> </ul>                                                                                                                                                                                                                                                     |
| inetd/rwalld  | inetd  | /etc/inetd.conf | write to all users                       | <ul style="list-style-type: none"> <li>• Runs as root user</li> <li>• If your systems have interactive users, you might need to keep this service</li> <li>• If your systems are production or database servers, this is not needed</li> <li>• Disable</li> </ul>                                                                                                                                                                                                |

| Service      | Daemon | Started by      | Function                                                     | Comments                                                                                                                                                                                                                                                                               |
|--------------|--------|-----------------|--------------------------------------------------------------|----------------------------------------------------------------------------------------------------------------------------------------------------------------------------------------------------------------------------------------------------------------------------------------|
| inetd/shell  | inetd  | /etc/inetd.conf | rsh service                                                  | <ul style="list-style-type: none"> <li>• Disable this service if possible. Use Secure Shell instead</li> <li>• If you must use this service, use the TCP Wrapper to stop spoofing and limit exposures</li> <li>• Required for the <b>Xhier</b> software ditribution program</li> </ul> |
| inetd/sprayd | inetd  | /etc/inetd.conf | RPC spray tests                                              | <ul style="list-style-type: none"> <li>• Runs as root user</li> <li>• Might be required for diagnosis of NFS network problems</li> <li>• Disable if you are not running NFS</li> </ul>                                                                                                 |
| inetd/systat | inetd  | /etc/inted.conf | "ps -ef" status report                                       | <ul style="list-style-type: none"> <li>• Allows for remote sites to see the process status on your system</li> <li>• This service is disabled by default. You must check periodically to ensure that the service has not been enabled</li> </ul>                                       |
| inetd/talk   | inetd  | /etc/inetd.conf | establish split screen between 2 users on the net            | <ul style="list-style-type: none"> <li>• Not a required service</li> <li>• Used with the <b>talk</b> command</li> <li>• Provides UDP service at Port 517</li> <li>• Disable unless you need multiple interactive chat sessions for UNIX user</li> </ul>                                |
| inetd/ntalk  | inetd  | /etc/inetd.conf | "new talk" establish split screen between 2 users on the net | <ul style="list-style-type: none"> <li>• Not a required service</li> <li>• Used with the <b>talk</b> command</li> <li>• Provides UDP service at Port 517</li> <li>• Disable unless you need multiple interactive chat sessions for UNIX user</li> </ul>                                |
| inetd/telnet | inetd  | /etc/inetd.conf | telnet service                                               | <ul style="list-style-type: none"> <li>• Supports remote login sessions, but the password and ID are passed unprotected</li> <li>• If possible, disable this service and use Secure Shell for remote access instead</li> </ul>                                                         |
| inetd/tftp   | inetd  | /etc/inetd.conf | trivial file transfer                                        | <ul style="list-style-type: none"> <li>• Provides UDP service at port 69</li> <li>• Runs as root user and might be compromised</li> <li>• Used by NIM</li> <li>• Disable unless you are using NIM or have to boot a diskless workstation</li> </ul>                                    |

| Service            | Daemon | Started by                            | Function                                           | Comments                                                                                                                                                                                                                                                                                                                                                                                                                  |
|--------------------|--------|---------------------------------------|----------------------------------------------------|---------------------------------------------------------------------------------------------------------------------------------------------------------------------------------------------------------------------------------------------------------------------------------------------------------------------------------------------------------------------------------------------------------------------------|
| inetd/time         | inetd  | /etc/inetd.conf                       | obsolete time service                              | <ul style="list-style-type: none"> <li>Internal function of <b>inetd</b> that is used by <b>rdate</b> command.</li> <li>Available as TCP and UDP service</li> <li>Sometimes used to synchronize clocks at boot time</li> <li>Service is outdated. Use <b>ntpd</b> instead</li> <li>Disable this only after you have tested your systems (boot/reboot) with this service disabled and have observed no problems</li> </ul> |
| inetd/tdbserver    | inetd  | /etc/inetd.conf                       | tool-talk database server (for CDE)                | <ul style="list-style-type: none"> <li>The <b>rpc.tdbserverd</b> runs as root user and might be compromised</li> <li>Stated as a required service for CDE, but CDE is able to work without it</li> <li>Should not be run on back room servers or any systems where security is a concern</li> </ul>                                                                                                                       |
| inetd/uucp         | inetd  | /etc/inetd.conf                       | UUCP network                                       | <ul style="list-style-type: none"> <li>Disable unless you have an application that uses UUCP</li> </ul>                                                                                                                                                                                                                                                                                                                   |
| inittab/dt         | init   | /etc/rc.dt script in the /etc/inittab | desktop login to CDE environment                   | <ul style="list-style-type: none"> <li>Starts the X11 server on the console</li> <li>Supports the X11 Display Manager Control Protocol (xdcm) so that other X11 stations can log into the same machine</li> <li>Service should be used on personal workstations only. Avoid using it for back room systems</li> </ul>                                                                                                     |
| inittab/dt_nogb    | init   | /etc/inittab                          | desktop login to CDE environment (NO graphic boot) | <ul style="list-style-type: none"> <li>No graphical display until the system is up fully</li> <li>Same concerns as inittab/dt</li> </ul>                                                                                                                                                                                                                                                                                  |
| inittab/httpd-lite | init   | /etc/inittab                          | web server for the <b>docsearch</b> command        | <ul style="list-style-type: none"> <li>Default web server for the docsearch engine</li> <li>Disable unless your machine is a documentation server</li> </ul>                                                                                                                                                                                                                                                              |

| Service          | Daemon | Started by   | Function                                     | Comments                                                                                                                                                                                                                                                                                                     |
|------------------|--------|--------------|----------------------------------------------|--------------------------------------------------------------------------------------------------------------------------------------------------------------------------------------------------------------------------------------------------------------------------------------------------------------|
| inittab/i4ls     | init   | /etc/inittab | license manager servers                      | <ul style="list-style-type: none"> <li>• Enable for development machines</li> <li>• Disable for production machines</li> <li>• Enable for back room database machines that have license requirements</li> <li>• Provides support for compilers, database software, or any other licensed products</li> </ul> |
| inittab/imqss    | init   | /etc/inittab | search engine for "docsearch"                | <ul style="list-style-type: none"> <li>• Part of the default web server for the docsearch engine</li> <li>• Disable unless your machine is a documentation server</li> </ul>                                                                                                                                 |
| inittab/lpd      | init   | /etc/inittab | BSD line printer interface                   | <ul style="list-style-type: none"> <li>• Accepts print jobs from other systems</li> <li>• You can disable this service and still send jobs to the print server</li> <li>• Disable this after you confirm that printing is not affected</li> </ul>                                                            |
| inittab/nfs      | init   | /etc/inittab | Network File System/Net Information Services | <ul style="list-style-type: none"> <li>• NFS and NIS services based which were built on UDP/RPC</li> <li>• Authentication is minimal</li> <li>• Disable this for back room machines</li> </ul>                                                                                                               |
| inittab/piobe    | init   | /etc/inittab | printer IO Back End (for printing)           | <ul style="list-style-type: none"> <li>• Handles the scheduling, spooling and printing of jobs submitted by the <b>qdaemon</b> daemon</li> <li>• Disable if you are not printing from your system because you are sending print job to a server</li> </ul>                                                   |
| inittab/qdaemon  | init   | /etc/inittab | queue daemon (for printing)                  | <ul style="list-style-type: none"> <li>• Submits print jobs to the <b>piobe</b> daemon</li> <li>• If you are not printing from your system, then disable</li> </ul>                                                                                                                                          |
| inittab/uprintfd | init   | /etc/inittab | kernel messages                              | <ul style="list-style-type: none"> <li>• Generally not required</li> <li>• Disable</li> </ul>                                                                                                                                                                                                                |
| inittab/writesrv | init   | /etc/inittab | writing notes to ttys                        | <ul style="list-style-type: none"> <li>• Only used by interactive UNIX workstation users</li> <li>• Disable this service for servers, back room databases, and development machines</li> <li>• Enable this service for workstations</li> </ul>                                                               |

| Service           | Daemon | Started by   | Function                                  | Comments                                                                                                                                                                                                                                                            |
|-------------------|--------|--------------|-------------------------------------------|---------------------------------------------------------------------------------------------------------------------------------------------------------------------------------------------------------------------------------------------------------------------|
| inittab/xdm       | init   | /etc/inittab | traditional X11 Display Management        | <ul style="list-style-type: none"> <li>Do not run on back room production or database servers</li> <li>Do not run on development systems unless X11 display management is needed</li> <li>Acceptable to run on workstations if graphics are needed</li> </ul>       |
| rc.nfs/automountd |        | /etc/rc.nfs  | automatic file systems                    | <ul style="list-style-type: none"> <li>If you use NFS, enable this for workstations</li> <li>Do not use the automounter for development or back room servers</li> </ul>                                                                                             |
| rc.nfs/biod       |        | /etc/rc.nfs  | Block IO Daemon (required for NFS server) | <ul style="list-style-type: none"> <li>Enabled for NFS server only</li> <li>If not an NFS server, then disable this along with nfsd and rpc.mountd</li> </ul>                                                                                                       |
| rc.nfs/keyserd    |        | /etc/rc.nfs  | Secure RPC Key server                     | <ul style="list-style-type: none"> <li>Manages the keys required for secure RPC</li> <li>Important for NIS+</li> <li>Disable this if you are <i>not</i> using NFS and NIS and NIS+</li> </ul>                                                                       |
| rc.nfs/nfsd       |        | /etc/rc.nfs  | NFS Services (required for NFS Server)    | <ul style="list-style-type: none"> <li>Authentication is weak</li> <li>Can lend itself to stack frame crashing</li> <li>Enable if on NFS file servers</li> <li>If you disable this, then disable <b>biod</b>, <b>nfsd</b>, and <b>rpc.mountd</b> as well</li> </ul> |
| rc.nfs/rpc.lockd  |        | /etc/rc.nfs  | NFS file locks                            | <ul style="list-style-type: none"> <li>Disable if you are not using NFS</li> <li>Disable this if you are not using file locks across the network</li> <li><b>lockd</b> daemon is mentioned in the SANS Top Ten Security Threats</li> </ul>                          |
| rc.nfs/rpc.mountd |        | /etc/rc.nfs  | NFS file mounts (required for NFS Server) | <ul style="list-style-type: none"> <li>Authentication is weak</li> <li>Can lend itself to stack frame crashing</li> <li>Should be enabled only on NFS file servers</li> <li>If you disable this, then disable <b>biod</b> and <b>nfsd</b> as well</li> </ul>        |
| rc.nfs/rpc.statd  |        | /etc/rc.nfs  | NFS file locks (to recover them)          | <ul style="list-style-type: none"> <li>Implements file locks across NFS</li> <li>Disable unless you are using NFS</li> </ul>                                                                                                                                        |

| Service              | Daemon | Started by    | Function                                  | Comments                                                                                                                                                                                                                                                                                                                           |
|----------------------|--------|---------------|-------------------------------------------|------------------------------------------------------------------------------------------------------------------------------------------------------------------------------------------------------------------------------------------------------------------------------------------------------------------------------------|
| rc.nfs/rpc.yppasswdd |        | /etc/rc.nfs   | NIS password daemon (for NIS master)      | <ul style="list-style-type: none"> <li>Used to manipulate the local password file</li> <li>Only required when the machine in question is the NIS master; disable in all other cases</li> </ul>                                                                                                                                     |
| rc.nfs/ypupdated     |        | /etc/rc.nfs   | NIS Update daemon (for NIS slave)         | <ul style="list-style-type: none"> <li>Receives NIS database maps pushed from the NIS Master</li> <li>Only required when the machine in question is a NIS slave to a Master NIS Server</li> </ul>                                                                                                                                  |
| rc.tcpip/autoconf6   |        | /etc/rc.tcpip | IPv6 interfaces                           | <ul style="list-style-type: none"> <li>Disable unless you are running IP Version 6</li> </ul>                                                                                                                                                                                                                                      |
| rc.tcpip/dhccpd      |        | /etc/rc.tcpip | Dynamic Host Configure Protocol (client ) | <ul style="list-style-type: none"> <li>Back room servers should not rely on DHCP. Disable this service</li> <li>If your host is not using DHCP, disable</li> </ul>                                                                                                                                                                 |
| rc.tcpip/dhcprd      |        | /etc/rc.tcpip | Dynamic Host Configure Protocol (relay)   | <ul style="list-style-type: none"> <li>Grabs DHCP broadcasts and sends them to a server on another network</li> <li>Duplicate of a service found on routers</li> <li>Disable this if you are not using DHCP or rely on passing information between networks</li> </ul>                                                             |
| rc.tcpip/dhcpsd      |        | /etc/rc.tcpip | Dynamic Host Configure Protocol (server)  | <ul style="list-style-type: none"> <li>Answers DHCP requests from clients at boot time; gives client information, such as IP name, number, netmask, router, and broadcast address</li> <li>Disable this if you are not using DHCP</li> <li>Disabled on production and back room servers along with hosts not using DHCP</li> </ul> |
| rc.tcpip/dpid2       |        | /etc/rc.tcpip | outdated SNMP service                     | <ul style="list-style-type: none"> <li>Disable unless you need SNMP</li> </ul>                                                                                                                                                                                                                                                     |
| rc.tcpip/gated       |        | /etc.rc.tcpip | gated routing between interfaces          | <ul style="list-style-type: none"> <li>Emulates router function</li> <li>Disable this service and use RIP or a router instead</li> </ul>                                                                                                                                                                                           |
| rc.tcpip/inetd       |        | /etc/rc.tcpip | inetd services                            | <ul style="list-style-type: none"> <li>A thoroughly secured system should have this disabled, but is often not practical</li> <li>Disabling this will disable remote shell services which are required for some mail and web servers</li> </ul>                                                                                    |

| Service             | Daemon | Started by    | Function                       | Comments                                                                                                                                                                                                                                                                                                                                                                                                                                          |
|---------------------|--------|---------------|--------------------------------|---------------------------------------------------------------------------------------------------------------------------------------------------------------------------------------------------------------------------------------------------------------------------------------------------------------------------------------------------------------------------------------------------------------------------------------------------|
| rc.tcpip/mrouted    |        | /etc/rc.tcpip | multi-cast routing             | <ul style="list-style-type: none"> <li>Emulates router function of sending multi-cast packets between network segments</li> <li>Disable this service. Use a router instead</li> </ul>                                                                                                                                                                                                                                                             |
| rc.tcpip/names      |        | /etc/rc.tcpip | DNS name server                | <ul style="list-style-type: none"> <li>Use this only if your machine is a DNS name server</li> <li>Disable for workstation, development and production machines</li> </ul>                                                                                                                                                                                                                                                                        |
| rc.tcpip/ndp-host   |        | /etc/rc.tcpip | IPv6 host                      | <ul style="list-style-type: none"> <li>Disable unless you use IP Version 6</li> </ul>                                                                                                                                                                                                                                                                                                                                                             |
| rc.tcpip/ndp-router |        | /etc/rc.tcpip | IPv6 routing                   | <ul style="list-style-type: none"> <li>Disable this unless you use IP Version 6. Consider using a router instead of IP Version 6</li> </ul>                                                                                                                                                                                                                                                                                                       |
| rc.tcpip/portmap    |        | /etc/rc.tcpip | RPC services                   | <ul style="list-style-type: none"> <li>Required service</li> <li>RPC servers register with <b>portmap</b> daemon. Clients who need to locate RPC services ask the <b>portmap</b> daemon to tell them where a particular service is located</li> <li>Disable only if you have managed to reduce RPC service so that the only one remaining is <b>portmap</b></li> </ul>                                                                            |
| rc.tcpip/routed     |        | /etc/rc.tcpip | RIP routing between interfaces | <ul style="list-style-type: none"> <li>Emulates router function</li> <li>Disable if you have a router for packets between networks</li> </ul>                                                                                                                                                                                                                                                                                                     |
| rc.tcpip/rwhod      |        | /etc/rc.tcpip | Remote "who" daemon            | <ul style="list-style-type: none"> <li>Collects and broadcasts data to peer servers on the same network</li> <li>Disable this service</li> </ul>                                                                                                                                                                                                                                                                                                  |
| rc.tcpip/sendmail   |        | /etc/rc.tcpip | mail services                  | <ul style="list-style-type: none"> <li>Runs as root user</li> <li>Disable this service unless the machine is used as a mail server</li> <li>If disabled, then do one of the following: <ul style="list-style-type: none"> <li>Place an entry in crontab to clear the queue. Use the <b>/usr/lib/sendmail -q</b> command</li> <li>Configure DNS services so that the mail for your server is delivered to some other system</li> </ul> </li> </ul> |

| Service               | Daemon | Started by                | Function                           | Comments                                                                                                                                                                                                                                                                                                                                                                                |
|-----------------------|--------|---------------------------|------------------------------------|-----------------------------------------------------------------------------------------------------------------------------------------------------------------------------------------------------------------------------------------------------------------------------------------------------------------------------------------------------------------------------------------|
| rc.tcpip/snmpd        |        | /etc/rc.tcpip             | Simple Network Management Protocol | <ul style="list-style-type: none"> <li>• Disable if you are not monitoring the system via SNMP tools</li> <li>• SNMP may be required on critical servers</li> </ul>                                                                                                                                                                                                                     |
| rc.tcpip/syslogd      |        | /etc/rc.tcpip             | system log of events               | <ul style="list-style-type: none"> <li>• Disabling this service is <i>not</i> recommended</li> <li>• Prone to denial of service attacks</li> <li>• Required in any system</li> </ul>                                                                                                                                                                                                    |
| rc.tcpip/timed        |        | /etc/rc.tcpip             | Old Time Daemon                    | <ul style="list-style-type: none"> <li>• Disable this service and use xntp instead</li> </ul>                                                                                                                                                                                                                                                                                           |
| rc.tcpip/xntpd        |        | /etc/rc.tcpip             | New Time Daemon                    | <ul style="list-style-type: none"> <li>• Keeps clocks on systems in sync</li> <li>• Disable this service.</li> <li>• Configure other systems as time servers and let other systems synchronize to them with a cron job that calls ntpdate</li> </ul>                                                                                                                                    |
| dt login              |        | /usr/dt/config/Xaccess    | unrestricted CDE                   | <ul style="list-style-type: none"> <li>• If you are not providing CDE login to a group of X11 stations, you can restrict dtlogin to the console.</li> </ul>                                                                                                                                                                                                                             |
| anonymous FTP service |        | user rmuser -p <username> | anonymous ftp                      | <ul style="list-style-type: none"> <li>• Anonymous FTP ability prevents you from tracing FTP usage to a specific user</li> <li>• Remove user ftp if that user account exists, as follows:<br/><b>rmuser -p ftp</b></li> <li>• Further security can be obtained by populating the <b>/etc/ftpusers</b> file with a list of those who should not be able to ftp to your system</li> </ul> |



| Service              | Daemon | Started by         | Function                      | Comments                                                                                                                                                                                                                                                                                                                                                                                                                                                                                                                                                                                                                                                                                                                                                    |
|----------------------|--------|--------------------|-------------------------------|-------------------------------------------------------------------------------------------------------------------------------------------------------------------------------------------------------------------------------------------------------------------------------------------------------------------------------------------------------------------------------------------------------------------------------------------------------------------------------------------------------------------------------------------------------------------------------------------------------------------------------------------------------------------------------------------------------------------------------------------------------------|
| anonymous FTP writes |        |                    | anonymous ftp uploads         | <ul style="list-style-type: none"> <li>• No file should belong to ftp.</li> <li>• FTP anonymous uploads allow the potential for misbehaving code to be placed on your system.</li> <li>• Put the names of those users you want to disallow into the <b>/etc/ftpusers</b> file</li> <li>• Some examples of system-created users you might want to disallow from anonymously uploading via FTP to your system are: root, daemon, bin.sys, admin.uucp, guest, nobody, lpd, nuucp, ladb</li> <li>• Change the owner and group rights to the <b>ftpusers</b> files as follows: <b>chown root:system /etc/ftpusers</b></li> <li>• Change the permissions to the <b>ftpusers</b> files to a stricter setting as follows: <b>chmod 644 /etc/ftpusers</b></li> </ul> |
| ftp.restrict         |        |                    | ftp to system accounts        | <ul style="list-style-type: none"> <li>• No user from the outside should be allowed to replace root files using <b>ftpusers</b> file</li> </ul>                                                                                                                                                                                                                                                                                                                                                                                                                                                                                                                                                                                                             |
| root.access          |        | /etc/security/user | rlogin/telnet to root account | <ul style="list-style-type: none"> <li>• Set the rlogin option in the <b>etc/security/user</b> file to false</li> <li>• Anyone logging in as root should first log in under their own name and then <b>su</b> to root; this provides an audit trail</li> </ul>                                                                                                                                                                                                                                                                                                                                                                                                                                                                                              |
| snmpd.readWrite      |        | /etc/snmpd.conf    | SNMP readWrite communities    | <ul style="list-style-type: none"> <li>• If you are <i>not</i> using SNMP, disable the SNMP daemon.</li> <li>• Disable community private and community system in the <b>/etc/snmpd.conf</b> file</li> <li>• Restrict 'public' community to those IP addresses that are monitoring your system</li> </ul>                                                                                                                                                                                                                                                                                                                                                                                                                                                    |
| syslog.conf          |        |                    | configure syslogd             | <ul style="list-style-type: none"> <li>• If you have not configured <b>/etc/syslog.conf</b>, then disable this daemon</li> <li>• If you are using <b>syslog.conf</b> to log system messages, then keep enabled</li> </ul>                                                                                                                                                                                                                                                                                                                                                                                                                                                                                                                                   |

---

## Summary of network service options

To achieve a higher level of system security, there are several network options that you can change using 0 to disable and 1 to enable. The following list identifies these parameters you can use with the **no** command.

| Parameter           | Command                               | Purpose                                                                                                                                                                             |
|---------------------|---------------------------------------|-------------------------------------------------------------------------------------------------------------------------------------------------------------------------------------|
| bcastping           | /usr/sbin/no -o bcastping=0           | Allows response to ICMP echo packets to the broadcast address. Disabling this prevents Smurf attacks.                                                                               |
| clean_partial_conns | /usr/sbin/no -o clean_partial_conns=1 | Specifies whether or not SYN (synchronizes the sequence number) attacks are being avoided.                                                                                          |
| directed_broadcast  | /usr/sbin/no -o directed_broadcast=0  | Specifies whether to allow a directed broadcast to a gateway. Setting to 0 helps prevent directed packets from reaching a remote network.                                           |
| icmpaddressmask     | /usr/sbin/no -o icmpaddressmask=0     | Specifies whether the system responds to an ICMP address mask request. Disabling this prevents access through source routing attacks.                                               |
| ipforwarding        | /usr/sbin/no -o ipforwarding=0        | Specifies whether the kernel should forward packets. Disabling this prevents redirected packets from reaching remote network.                                                       |
| ipignoreredirects   | /usr/sbin/no -o ipignoreredirects=1   | Specifies whether to process redirects that are received.                                                                                                                           |
| ipsendredirects     | /usr/sbin/no -o ipsendredirects=0     | Specifies whether the kernel should send redirect signals. Disabling this prevents redirected packets from reaching remote network.                                                 |
| ip6srcrouteforward  | /usr/sbin/no -o ip6srcrouteforward=0  | Specifies whether the system forwards source-routed IPv6 packets. Disabling this prevents access through source routing attacks.                                                    |
| ipsrcrouteforward   | /usr/sbin/no -o ipsrcrouteforward=0   | Specifies whether the system forwards source-routed packets. Disabling this prevents access through source routing attacks.                                                         |
| ipsrcrouterrecv     | /usr/sbin/no -o ipsrcrouterrecv=0     | Specifies whether the system accepts source-routed packets. Disabling this prevents access through source routing attacks                                                           |
| ipsrcroutesend      | /usr/sbin/no -o ipsrcroutesend=0      | Specifies whether applications can send source-routed packets. Disabling this prevents access through source routing attacks.                                                       |
| nonlocsroute        | /usr/sbin/no -o nonlocsroute=0        | Tells the Internet Protocol that strictly source-routed packets may be addressed to hosts outside the local network. Disabling this prevents access through source routing attacks. |

| Parameter         | Command                             | Purpose                                                                                                                                                                                                                                                                                                 |
|-------------------|-------------------------------------|---------------------------------------------------------------------------------------------------------------------------------------------------------------------------------------------------------------------------------------------------------------------------------------------------------|
| tcp_icmpsecure    | /usr/sbin/no -o tcp_icmpsecurer=1   | Protects TCP connections against ICMP (Internet Control Message Protocol) source quench and PMTUD (Path MTU Discovery) attacks. Checks the payload of the ICMP message to test the sequence number of the TCP header is within the range of acceptable sequence numbers. Values: 0=off (default); 1=on. |
| ip_nfrag          | /usr/sbin/no -o ip_nfrag=200        | Specifies the maximum number of fragments of an IP packet that can be kept on the IP reassembly queue at a time (default value of 200 keeps up to 200 fragments of an IP packet in the IP reassembly queue).                                                                                            |
| tcp_pmtu_discover | /usr/sbin/no -o tcp_pmtu_discover=0 | Disabling this prevents access through source routing attacks.                                                                                                                                                                                                                                          |
| tcp_tcpsecure     | /usr/sbin/no -o tcp_tcpsecure=7     | Protects TCP connections against vulnerabilities. Values: 0=no protection; 1=sending a fake SYN to an established connection; 2=sending a fake RST to an established connection; 3=injecting data in an established TCP connection; 5–7=combination of the above vulnerabilities.                       |
| udp_pmtu_discover | /usr/sbin/no -o udp_pmtu_discover=0 | Enables or disables path MTU discovery for TCP applications. Disabling this prevents access through source routing attacks.                                                                                                                                                                             |

For more information about network-tunable options, see *Performance management*.

---

## Trusted AIX

Trusted AIX enables Multi Level Security (MLS) capabilities in AIX.

**Note:** MLS is also referred to as label-based security.

As compared to regular AIX, Trusted AIX label-based security implements labels for all subjects and objects in the system.

**Note:** The Trusted AIX install option enables the Labeled Security AIX environment. Access controls in the system are based on labels that provide for a Multi Level Security (MLS) environment and includes support for the following:

- Labeled objects: Files, IPC objects, network packets, and other labeled objects
- Labeled printers
- Trusted Network: Support for RIPS0 and CIPS0 in IPv4 and IPv6

Please note that once you choose this mode of installation, you will not be able to go back to a regular AIX environment without performing an overwrite install of regular AIX. Evaluate your need

for a Trusted AIX environment before choosing this mode of install. More details about Trusted AIX can be found in the AIX publicly available documentation.

Standard AIX provides a set of security features to allow information managers and administrators to provide a basic level of system and network security. The primary AIX security features include the following:

- login and password controlled system and network access
- user, group, and world file access permissions
- access control lists (ACLs)
- Audit subsystem
- Role Based Access Control (RBAC)

Trusted AIX builds upon these primary AIX operating system security features to further enhance and extend AIX security into the networking subsystems.

Trusted AIX is compatible with the AIX application programming interface (API). Any application that runs on AIX can also run on Trusted AIX. However, due to additional security restrictions, MLS-unaware applications may need privileges to operate in a Trusted AIX environment. The **tracepriv** command can be used to profile applications in such scenarios.

Trusted AIX extends the AIX API to support additional security functionality. This allows customers to develop their own secure applications can be developed using the AIX API and new Trusted AIX extensions.

Trusted AIX enables AIX systems to process information at multiple security levels. It is designed to meet the US Department of Defense (DoD) TCSEC and European ITSEC criteria for enhanced B1 security.

See *Securing the Base Operating System* and *Securing the Network* for information on standard AIX security.

## Introduction to Trusted AIX

Trusted AIX enhances the security of the standard AIX operating system by providing for label-based-security capabilities within the operating system.

Trusted AIX label-based environment can be installed by choosing the install time options. If you install Trusted AIX, you will not be able to go back to a regular AIX environment without performing an overwrite install of regular AIX. Once installed, Trusted AIX environment will apply to the entire AIX system, including any WPARs created within the AIX environment. While label based security (also termed as Multi Level Security, or MLS) is often used in the defence and intelligence industries, it can also be used in the commercial industries. This can be achieved by customizing the labels available on Trusted AIX. A fresh install of Trusted AIX provides for labels that adhere to standard MLS implementations.

Trusted AIX environment consists of regular AIX with some additional packages and file sets. Additionally, kernel switches will force the kernel to operate in Trusted AIX mode. When booted through a CD or DVD, the system boots in the regular AIX environment. When install menus are displayed, the installer can choose the Trusted AIX option and start installing the MLS-related files. When installation is complete, the installer must initiate the first boot resequence. During the first boot sequence, Config Assistant provides menus for the various users and ISSO, SA, and SO users are set up; then, the system completes the boot operation and the MLS is established.

Trusted AIX enhances system security through four primary elements of information security:

- Confidentiality
- Integrity

- Availability
- Accountability

In addition to the security features provided by AIX, Trusted AIX adds the following capabilities:

#### **Sensitivity labels (SLs)**

All processes and files are labeled according to their security level. Processes can only access objects that are within the process' security range.

#### **Integrity labels (TLs)**

All processes and files are labeled according to their integrity level. Files cannot be written by processes that have a lower integrity level label than the file. Processes cannot read from files that have a lower integrity level label than the process.

#### **File security flags**

Individual files can have additional flags to control security related operations.

#### **Kernel security flags**

The entire system can have different security features enabled or disabled.

#### **Privileges**

Many commands and system calls are only available to processes with specific privileges.

#### **Authorizations**

Each user can be granted a unique set of authorizations. Each authorization allows the user to perform specific security-related functions. Authorizations are assigned to users through roles.

**Roles** Role Based Access Control function, as part of Trusted AIX, provides for selective delegation of administrative duties to non-root users. This delegation is achieved by collecting the relevant authorizations into a Role and then assigning the role to a non-root user.

### **Confidentiality**

Threats centered around disclosure of information to unauthorized parties are a confidentiality issue.

Trusted AIX provides object reuse and access control mechanisms for protecting all data resources. The operating system ensures that protected data resources can only be accessed by specifically authorized users and that those users cannot make the protected resources available to unauthorized users either deliberately or accidentally.

Administrators can prevent sensitive files from being written to floppy disks or other removable media, from being printed on unprotected printers, or from being transferred over a network to unauthorized remote systems. This security protection is enforced by the operating system and cannot be bypassed by malicious users or rogue processes.

### **Integrity**

Threats centered around modification of information by unauthorized parties are an integrity issue.

Trusted AIX offers numerous security mechanisms which ensure the integrity of trusted computing base and protected data, whether the data is generated on the system or imported via network resources. Various access control security mechanisms ensure that only authorized individuals can modify information. To prevent malicious users or rogue processes from seizing or disabling system resources, Trusted AIX eliminates the root privilege. Special administrative authorizations and roles allow the separation of administration duties, rather than giving a user root privileges.

## Availability

Threats centered around accessibility of services on a host machine are an availability issue. For example, if a malicious program fills up file space so that a new file cannot be created, there is still access, but no availability.

Trusted AIX protects the system from attacks by unauthorized users and processes that can create a denial of service. Unprivileged processes are not allowed to read or write protected files and directories.

## Accountability

Threats centered around not knowing which processes performed which actions on a system are an accountability issue. For example, if the user or process that altered a system file cannot be traced, you cannot determine how to stop such actions in the future.

This enhanced security feature ensures identification and authentication of all users prior to allowing user access to the system. The audit services provide the administrator a set of auditable events and an audit trail of all security-related system events.

## Notes about Trusted AIX

- Trusted AIX is installed through the AIX install menus. Additional options can be chosen during installation of Trusted AIX. The option related to LSPP EAL4+ configuration is supported.
- Trusted AIX environment cannot revert to regular AIX environment without performing an overwrite install of regular AIX.
- Root is disabled from logging in a Trusted AIX environment.
- In a Trusted AIX environment, any WPARs created will also operate in the Labeled Security environment.
- Trusted AIX supports both MAC (Mandatory Access Control) and MIC (Mandatory Integrity Control). Customer can define separate sets of labels for MAC and MIC.
- Label Encodings file is located in the `/etc/security/enc` directory and captures the label-to-binary translation information. The default Label Encodings file adheres to the Compartmented Mode Workstations (CMW) labels-related naming requirements.
- NIM installs are supported when initiated from Client. NIM install push from Server is not possible because root is disabled for logins on MLS systems.
- The JFS2 (J2) file system (using Extended Attributes version 2) has been enabled for storing Labels in AIX. Other file systems (such as J1 or NFS) can only be mounted in a Trusted AIX environment as single-level file systems (label assigned to the mount point).
- X environment is disabled for Trusted AIX.
- Trusted AIX supports CIPSO and RIPS0 protocols for network-based label-based communication. These protocols are supported for both IPv4 and IPv6.
- Some AIX security mechanisms are common between regular AIX and Trusted AIX. Two of these common security mechanisms are Role Based Access Control (RBAC) and Trusted Execution for integrity verification.
- Since root is disabled when Trusted AIX is installed, the installer must set up passwords for ISSO, SA, and SO users during the first boot after install. The system remains usable until these passwords are created.
- The AIX 6 security features Redbook contains use cases and examples for Trusted AIX.

## Multi-level security

The main goal of a secure system is to enforce a site security policy to provide accountability and availability.

The Trusted AIX security policy provides a defined set of rules that determine the types of allowable system access. This includes holding users accountable for their actions and preventing changes to the operating system.

Trusted AIX uses access control and specific need-to-know criteria to control access to files, directories, processes, and devices.

Trusted AIX maintains an audit trail of all security-relevant events. This audit trail allows for individual accountability, even with programs which modify effective and real user IDs, such as the **su** command. Trusted AIX also restricts administrative functions to specific individuals with authorizations and least privilege (the granting of the most restrictive set of privileges that will permit a user or process to perform an operation).

## Identification and authentication

Identification and authentication (I&A) security mechanisms are responsible for assuring that each individual requesting access to the system is properly identified and authenticated. Identification requires a user name and authentication requires a password

All Trusted AIX accounts are password protected. The ISSO (Information Systems Security Officer) can configure the system to allow a user to select his/her own password, subject to password length and complexity constraints. The ISSO can also specify minimum and maximum password aging parameters (expiration periods) on a per-user basis, including warning periods prior to password expiration.

The identification and authentication security mechanisms require that all usernames and user IDs be unique. Accounts without valid passwords cannot be used for login. A user with the ISSO role must add the initial password for all new users. Each user is assigned an additional unique identifier that is used for auditing purposes.

Only the encrypted form of the password is stored. Passwords are not stored on the system in plain text form. The encrypted passwords are stored in a shadow password file, which is protected against access except by privileged processes. For more information, see the **passwd** command.

Trusted AIX systems recognize two types of accounts: system accounts and user accounts. System accounts are those with a user ID less than 128. Although system accounts may have associated passwords, they cannot be used for logging on to the system.

## Discretionary access control

Discretionary access controls (DAC) are the security aspects that are under the control of the file or directory owner.

## UNIX permissions

A user with owner access to a resource can do the following:

- Directly grant access to other users
- Grant access to a copy to other users
- Provide a program to allow access to the original resource (for example, using SUID programs)

The traditional UNIX permission bit method (owner/group/other and read/write/execute) is an example of this DAC functionality.

Permission bits enable users to grant or deny access to the data in a file to users and groups (based on the need-to-know criterion). This type of access is based on the user ID and the groups to which the user belongs. All file system objects have associated permissions to describe access for the owner, group, and world.

The owner of a file can also grant access privileges to other users by changing the ownership or group of the file with the **chown** and **chgrp** commands

## **umask**

When a file is created, all permission bits are initially turned on. The file then has certain permission bits removed by the umask process, which has been set during the login process. The default umask applies to every file created by the user's shell and every command run from the user's shell.

By default, the umask setting for kernel items is 000 (which leaves all permissions available to all users). AIX sets the kernel umask to 022 (which turns off group and world write permission bits). However, users may override this setting if needed.

**Note:** Be very cautious about changing the umask to a setting more permissive than 022. If more permissions are available on files and processes, the system as a whole becomes less secure. There are two methods to override the default umask setting:

- You can change the umask values in your **.profile**, **.login**, or **.chsrc** files. These changes will affect any file that is created during your login session.
- You can set the umask levels for individual processes with the **umask** command. After running the **umask** command, all new files that are created will be affected by the new umask value until one of the following two events occur:
  - You run the **umask** command again
  - OR
  - You exit the shell in which the **umask** command was issued

If you run the **umask** command with no arguments, the **umask** command returns the current umask value for your session.

You should allow the login session to inherit the kernel's 022 umask value by not specifying a umask in your profiles. Umask values less restrictive than 022 should only be used with great caution.

If additional permissions are needed for certain files, these permissions should be set with judicious use of the **chmod** command after the files have been created.

## **Access Control Lists**

In addition to the standard UNIX permission bits and umask value, AIX also supports access control lists (ACLs).

UNIX permission bits only control access for the file owner, one group, and everyone on the system. With an ACL, a file owner can specify access rights for additional specific users and groups. Like permission bits, ACLs are associated with individual system objects, such as file or directory.

## **setuid and setgid permission bits**

The setuid and setgid permission bits (set user ID and set group ID) allow a program file to run with the user ID or group ID of the file owner rather than the user ID or group ID of the person who is running the program. This is accomplished by setting the setuid and setgid bits that are associated with the file. This permits the development of protected subsystems, where users can access and run certain files without having to own the files.

If the setgid bit is set on a parent directory when an object is created, the new object will have the same group as the parent directory, rather than the group of the object's creator. However, objects created in a directory with the setuid bit set are owned by the object's creator, not the directory owner. The setuid/setgid bits of the parent directory are inherited by subdirectories when subdirectories are created.



The `setuid` and `setgid` permission bits represent a potential security risk. A program that is set to run with root as the owner could have essentially unlimited access to the system. On Trusted AIX systems, however, the use of privileges and other access controls significantly reduces this security risk.

## Role Based Access Control elements

Trusted AIX supports Role Based Access Control (RBAC). RBAC an operating system mechanism through which the root/system super user specific system functions can also be performed by regular users using the roles that are assigned to them.

The core elements of AIX RBAC are:

### Authorizations

These strings indicate the privilege operation that they represent and control by name directly. For example an authorization string `aix.network.manage` defines the network management function in AIX.

### Privileges

A privilege is an attribute of a process that allows the process to bypass specific system restrictions and limitations. Privileges are associated with a process and are typically acquired through the execution of a privileged command.

**Roles** Role elements in AIX RBAC allow users to combine a set of management functions in the system and assign these functions to be managed by a regular user. Roles in AIX consist of a collection of authorizations (these can be both system authorizations as well as custom authorizations) and any other roles (as sub roles).

See RBAC for more information on Role Based Access Control.

## Mandatory Access Control

Mandatory access control is a system-enforced method of restricting access to objects based on the sensitivity of the object and the clearance of the user. By contrast, Discretionary Access Control is enforced by individual file owners rather than by the system.

### Use of labels for MAC

Trusted AIX uses a system of labels to enforce MAC. On a Trusted AIX system, all named objects have sensitivity labels (SLs) to identify the object's sensitivity level. Processes also have SLs. Process SLs indicate which levels of sensitive information the processes are allowed to access. In general, a process must have a sensitivity level equal to or greater than that of an object in order to access the object. The SLs can be used to make files read-only accessible or to completely prevent files from being accessed by regular users.

All system objects such as files, IPC objects, network connections, and processes, have SLs. SLs are automatically placed on objects when the objects are created. All core dumps are considered objects and are automatically labeled by the system.

Objects that exist prior to the installation of Trusted AIX receive the default `SYSTEM_LOW` SLs (SLSL) when these objects are accessed after Trusted AIX installation. The SLs are not set permanently on these objects. The `settxattr` command must be run on the object to set the SLs. For objects that are created after Trusted AIX installation, the object's SLs are set to the SL of the creating process.

### Users and labels

The system assigns each user account a range of valid SLs, either by system default or by a user-specific setting, and the user can only operate within this range. A process or user can only create files and directories at the current sensitivity label of the process or user and can only read and write files subject to the system-imposed MAC restrictions.

## MAC enforcement

Mandatory Access Control is enforced any time a process attempts to open a file system object, retrieve the attributes of a file system object, send a signal to a process, transfer data through a STREAM, or send or receive a packet through a network interface. Access to any file system object is only possible if both MAC and DAC criteria are met. When a user attempts to access a file, MAC restrictions are enforced before DAC restrictions, such as permission bits or ACLs, are checked.

Access to file system objects is restricted not only by the SL of the object but also by the SL of the directory in which the object resides. Thus, a file system object can be protected at a different sensitivity level (the directory's SL) than the SL of the object itself. A file system object can have multiple names (links) located in one or more directories. Although each name (link) is protected at the same SL as the file to which the link points, the effective protection of the various links may differ because the links are in directories with different levels of protection.

The name of an object is stored in the directory where the object resides. Thus, any process with access to that directory is able to view the names of all objects in the directory. However, only processes with proper access may read from or write to one of the objects.

## Listing and changing SLs

The SLs of objects and processes on the system can be viewed with the **lstxattr** command and can be modified using the **setxattr** commands.

Only users with proper authorizations and processes with the proper privileges can change the SL of a file or process.

With the **setxattr** command, to change a filesystem object SL to a lower-level SL the user should have the `aix.mls.label.sl.downgrade` authorization. To upgrade a filesystem object SL the user should have the `aix.mls.label.sl.upgrade` authorization. To alter the SL of processes, to upgrade the user should have `aix.mls.proc.sl.upgrade` authorization and to downgrade the user should have `aix.mls.proc.sl.downgrade` authorization.

## MAC on open file descriptors

For read/write and simple file accesses, MAC checks are performed when a process accesses a file. Once a process has a file descriptor for the file, it can read and write the file even if the process SL changes to a level lower than the SL of the file. However, some operations, such as setting file owner, permissions, labels, and privileges, perform access checks after a process has obtained a file descriptor.

This means that MAC checks and partitioned directory path resolutions are not performed when a process accesses a file using a file descriptor. The SL of the file and/or process may change and access is still permitted.

## Mandatory Integrity Control

Mandatory Integrity Control is a system-enforced method of restricting access to and modification of objects based on the integrity of the object and the clearance of the user. While MAC is concerned with the sensitivity of an object, MIC is concerned with the object's trustworthiness.

## Use of labels for MIC

Trusted AIX uses a system of labels to enforce MIC. On a Trusted AIX system, all named objects have integrity labels (TLs) to identify the object's integrity level. Processes also have TLs. Process TLs indicate which level of information integrity the process is allowed to access. The higher the TL, the more trustworthy the object or process is.

A process must be at least as trustworthy as an object in order to modify the object. Therefore, a process must have a TL equal to or greater than the TL of the object. Therefore, integrity labels can be used to make files accessible for read-only.

In addition, a process cannot use data from an object that is less trustworthy than the process itself. Therefore, an object must have a TL equal to or greater than that of the process.

All system objects, such as files and processes, have TLs. TLs are automatically placed on objects when the objects are created. All core dumps are considered objects and are automatically labeled by the system.

Objects that exist on the system prior to the installation of Trusted AIX receive the default SYSTEM\_LOW TL (SLTL) whenever the objects are accessed after Trusted AIX installation. The TLs are not set permanently on these objects. The **setxattr** command must be run on these objects to set the TLs. For objects that are created after Trusted AIX installation, the TLs of these objects are set to the integrity level of the process that created the objects.

## Users and labels

The system assigns each user account a range of valid TLs, either by system default or by a user-specific setting, and the user can only operate within this range. A process or user can only create files and directories at the current TL of the process or user, and can only read and write files subject to the system-imposed MIC restrictions.

## MIC enforcement

Mandatory Integrity Control is enforced whenever MAC is enforced. Additionally, MIC is enforced when a file or directory is deleted or renamed.

## Changing TLs

The TLs of objects and processes can be viewed with the **lstxattr** command and modified with the **setxattr** command.

Only users with proper authorizations and processes with the proper privileges can change the TL of a file or process. With the **setxattr** command, to change a filesystem object TL to a lower-level TL, the user should have the `aix.mls.label.tl.downgrade` authorization. To upgrade a filesystem object TL the user should have the `aix.mls.label.tl.upgrade` authorization. To alter the TL of processes, to upgrade the user should have `aix.mls.proc.tl.upgrade` authorization and to downgrade the user should have `aix.mls.proc.tl.downgrade` authorization.

## NOTL

There is a special TL, NOTL, that can be applied on file systems, ipc objects, or processes. When an object or process has an NOTL TL, no MIC checks are performed on the object or process. Only privileged users can set a TL to NOTL or change a TL if the TL is currently NOTL.

## MIC on open file descriptors

For read/write and simple file accesses, MIC checks are performed when a process accesses a file. Once a process has a file descriptor for a file, it can read and write the file even if the process TL changes to a level lower than the file's TL. However, some operations, such as setting file owner, permissions, labels, and privileges, perform access checks after a process has obtained a file descriptor. This means that MIC checks are not performed when a process accesses a file using a file descriptor. The TL of the file and/or process may change and access will still be permitted.

## Labels

Labels are used to represent security levels for subjects and objects on Trusted AIX systems. The labels to be used in a system and the relationship between labels are defined by the ISSO.

### ***Sensitivity labels (SLs):***

The SLs associated with each subject and object are used to enforce a mandatory access control policy based on the Bell-LaPadula Model of access control.

An SL consists of two parts:

- A hierarchical classification
- A set of one or more compartments

Each installation site can define the names and relationships of the labels on that system. A system administrator can set up these names and relationships as required by site policies in the label encodings file.

### ***SL classifications:***

Classifications have a hierarchical order and represent a level of sensitivity.

For example, if Top Secret, Secret, and Unclassified are valid classifications at a site, Top Secret is more sensitive than Secret and Secret is more sensitive than Unclassified. Trusted AIX supports up to 32,000 hierarchical classifications.

### ***SL compartments:***

Compartments represent topics or work groups. Each compartment has a name, such as NATO or CRYPTO.

Compartments have no intrinsic ordering, but the ISSO can impose constraints on which compartments and classifications can be combined. Trusted AIX supports up to 1,024 compartments.

### ***SL components:***

In human-readable form, an SL is represented by a string of elements. The first element represents the classification; the remaining elements represent the compartments. The elements are separated by a space.

For example, if a file contains top secret information regarding the Brazilian economy, the hierarchical classification of the file could be top secret (TS), and the compartments might be Brazil (B) and economy (e). The human-readable form of the SL would be TS B e or Top Secret Brazil economy.

### ***SL relationships:***

As a system user, it is important to understand the relationships between labels and how labels are used.

There are three types of relationships between MAC labels:

- Dominance
- Equality
- Non-Comparable

### **Dominance**

One SL (L1) is said to dominate another (L2) only if both of the following conditions are true:

- The classification in L1 equals or exceeds the classification in L2

- The set of compartments in L1 completely contains the set of compartments in L2

For example, if we assume one SL L1 of top secret information on the compartments A and B (TS A B), and another SL L2 of secret information on the compartment A but not B (S A), then TS A B would dominate S A because the classification TS dominates classification S and the set of compartments in L1 completely contains the set of compartments in L2. L2 would not dominate L1 in this example.

Table 29. SL dominance

| L1         |             | L2     |             | Dominance |
|------------|-------------|--------|-------------|-----------|
| Label      | Compartment | Label  | Compartment |           |
| TOP SECRET | A,B         | SECRET | A           | L1 > L2   |

## Equality

One SL (L1) is said to equal another SL (L2) only if both of the following conditions are true:

- The classification in L1 equals the classification in L2
- The set of compartments in L1 is identical to the set of compartments in L2

If two labels are equal, then each label dominates the other. For example, if we assume the SL for a file with top secret information on compartment A (TS A) and another file with top secret information on the compartment A (also TS A), then the SLs would be equal and would dominate each other.

Table 30. SL equality

| L1         |             | L2         |             | Dominance |
|------------|-------------|------------|-------------|-----------|
| Label      | Compartment | Label      | Compartment |           |
| TOP SECRET | A           | TOP SECRET | A           | L1 = L2   |

## Non-comparable

Two SLs can be disjoint (L1 is not equal to L2, L1 does not dominate L2, and L2 does not dominate L1). One SL (L1) is said to be non-comparable to another (L2) only if the following condition is true:

- The set of compartments in L1 does not completely contain the set in L2 and L2 does not completely contain the set in L1. Therefore, L1 and L2 are considered disjoint

For example, if we assume that a file with label L1 has top secret information on the compartments A and B (TS A B), and L2 is the label for a file with classified information on the compartment C (C C), then L1 is non-comparable to L2.

Table 31. Non-comparable SLs

| L1         |             | L2         |             | Dominance |
|------------|-------------|------------|-------------|-----------|
| Label      | Compartment | Label      | Compartment |           |
| TOP SECRET | A, B        | CLASSIFIED | C           | -         |

## Integrity labels (TLs):

TLs represent the level of trust in a system object or process. The structure of TLs is the same as that of SLs, except that TLs have only hierarchical classifications and no compartments.

A process can modify or delete an object only if the TL of the process dominates the TL of the object. A process can delete or rename an object only if the TL of the process dominates both the TL of the object and the TL of the directory where the object resides. A process can access an object only if the TL of the object dominates the TL of the process.

To determine the TL of an object or process, use the **lstxattr** command. To change the TL of an object or process, use the **setxattr** command.

### ***Labels on subjects and objects:***

In Trusted AIX, processes are identified as subjects and each process has SLs.

The SL used for MAC checks is called the Effective SL (ESL). An ESL must lie within the process clearance ranges. The clearance range has an upper bound and a lower bound. The upper bound is called the Maximum clearance (Max CL) and the lower bound is called the Minimum clearance (Min CL). The ESL, Max CL, and Min CL are stored in the process credential structure and are assigned during process creation. The Max CL must dominate Min CL and ESL and the ESL must dominate Min CL. The **setxattr** and **lstxattr** commands can be used to list and set the SLs of processes.

Access to various objects in the system need to be controlled. An object could be any one of the following:

- process
- files (Data files or binaries)
- IPC objects, network packets, etc.

All objects and subjects on a MLS system are labeled.

### **Directory**

Directories are associated with a SL range; minimum SL and maximum SL. The maximum SL should dominate or equal the minimum SL. All files in a directory lie within this range.

**Files** Regular files are associated with two SLs but their values are always the same. So effectively they have only one SL. Symbolic links could have different values for the SLs.

### **Special Files**

Special files like devices, ttys, and fifos are associated with a maximum and minimum SL. Directory, files, and special files have only one integrity label (TL) where as processes are associated with a minimum and maximum TLs.

### **Process**

All processes are associated with maximum and minimum sensitivity clearance range as well as a maximum and minimum integrity clearance range. These values are inherited from the user's clearance values. The sensitivity and integrity level at which the process is executing is known as the effective sensitivity and effective integrity levels.

### ***User clearance labels:***

Users have maximum and minimum sensitivity clearance labels (SCLs) and maximum and minimum integrity clearance labels (TCLs)

### **Maximum and minimum sensitivity clearance labels**

Each user has a maximum sensitivity clearance label (max SCL). The user's effective SL must be dominated by the max SCL. The max SCL is used to restrict certain users from viewing highly sensitive data. The min SCL is used to prevent users at a high security level from transmitting data to users at a lower security level.

For example, assume that user A has a max SCL and min SCL both of PUBLIC\_A, and user B has a max SCL and min SCL both of PUBLIC\_B. Without a min SCL, user A could communicate information to user B by logging in with an effective SL of IMPL\_L0 and writing to a file that user B could then read. With the min SCL, however, user A must log in at PUBLIC\_A and can only write files at PUBLIC\_A. Any files written at PUBLIC\_A are not readable by user B.

## Maximum and minimum integrity clearance labels

Each user also has a maximum integrity clearance label (max TCL). The user's effective TL must be dominated by the max TCL. The max TCL is used to restrict certain users from viewing highly sensitive data. The min TCL is also used to prevent users at a high security level from transmitting data to users at a lower security level.

### *Labels on file system objects:*

All files include specific security information. When a new file is created, it has the same SL as the process that created the file. The SL of the information in a file can be upgraded or downgraded by raising or lowering the file's SL.

Directories are assigned a minimum and maximum SL when the directories are created. On creation, both are set equal to the effective SL of the creating process, essentially creating a single-level directory. Only users with the proper privileges and authorizations can change these SLs. New objects can be created in this directory only if the effective SL of the process creating the new object falls within the range of the directory's SLs.

A window is normally created as a separate child process with an SL equal to the user's effective SL. Devices (for example, the pseudo-terminals associated with windows) also have SLs associated with them. A named pipe, which is a device used for interprocess communication, inherits the effective SL of the process that created the named pipe. A stream, which is a device used to provide a bidirectional data channel for interprocess communications, also inherits the effective SL of the process that created the stream.

All devices have a minimum SL and a maximum SL. The maximum SL must dominate the minimum SL. By default, the minimum SL and maximum SL are set equal. A process can only access such a device in read mode if the process's SL dominates the minimum SL of the device or directory. A process may only access such a device in write mode if the process's SL is within the range defined by the minimum and maximum SLs of the device or directory.

## File security flags

Objects can be marked with file security flags (FSFs) that affect the way processes deal with the objects. See File Security Flags for a list of FSFs and the privileges required to set each FSF. Processes do not have file security flags.

### *Removing files:*

You can only remove an object from a file system if the following are true:

- The process attempting to remove the object must be able to see the filename in the directory that contains the file. That is, the process must have search access in each directory in the path down to the directory from which the object is to be removed, and the process must have an effective SL that dominates each of these directories. Use the **ls** command to see file name.
- The process must have write access to the directory from which the object is to be removed.

### *Printing files:*

The printer subsystem automatically labels all output with the appropriate sensitivity labels. Each print job is automatically provided a banner page and a trailer page that show all security relevant labels and markings.

### *Backing up and restoring files:*

When writing to disks or tapes on AIX with the **backup** command, SLs are included with the data.

SO authorization is required to use the **backup** or **restore** commands to import or export unlabeled data from tapes or disks. When unlabeled data is written, the data is assigned a default SL of SYSTEM\_LOW for files and an SL range of SYSTEM\_LOW to SYSTEM\_HIGH for directories.

### ***Labels on IPC objects:***

All AIX IPC facilities involve the creation and access of intermediary objects.

There are three different IPC facilities defined in AIX:

- Message queues
- Semaphores
- Shared memory

All of these involve creating and accessing intermediary objects, called IPC objects, for interprocess communication. Each IPC object is protected by a set of attributes similar to the attributes that protect files. These attributes are:

- The user ID and group ID of the object owner
- The user ID and group ID of the object creator
- The resource access mode, which is analogous to file access permission bits. Each object has read, write, and execute access for world, group, and object owner.
- A sequence number to track resource usage
- A key to identify the resource

As with other system objects, Trusted AIX extends these attributes with additional security attributes. On a Trusted AIX system, all IPC objects also have the following attributes:

- A sensitivity label (SL)
- An integrity label (TL)

You can use the **settxattr** command to view all of the security attributes of an IPC object. Reading an IPC object's attributes requires DAC READ and MAC READ access to the object.

### ***Access to IPC objects:***

IPC objects are created, deleted, and accessed via several system calls that are discussed in the Trusted AIX Programmer's guide chapter. Typical users do not perform these operations. This topic presents a general overview of the rules for the creation, deletion, and access of IPC objects.

To access an IPC object, a process must pass DAC, MIC, and MAC access checks.

DAC access checks are based on the mode (owner, group, or world) of the object and the user and group IDs of the process. A process has DAC owner access to an IPC object if the process effective UID is the same as either the object owner UID or object creator UID. This also applies to DAC group access.

MAC access is based on the SLs of the process and object. MIC access is based on the TLs of the process and object.

Access rules for IPC object contents are the same as for IPC object attributes. To read either the contents or attributes of an IPC object, DAC READ, MIC READ, and MAC READ access are required. To write to an IPC object, DAC WRITE, MIC WRITE, and MAC WRITE access is required.

IPC object attributes are more tightly restricted than IPC object contents. Changing IPC object attributes therefore requires greater privilege. To modify standard AIX attributes such as mode, a process needs DAC OWNER and MAC WRITE access to the object. To change the SL of an IPC object, the process must have all of the following:



- PV\_SL\_PROC privilege
- DAC OWNER (downgrade only)
- DAC WRITE
- MAC WRITE
- PV\_SL\_UG privilege to upgrade SL, or PV\_SL\_DG privilege to downgrade SL
- PV\_MAC\_CL if existing or new SL outside clearance of process
- MIC WRITE

To change the TL of an IPC object, the process must have all of the following:

- PV\_TL privilege
- DAC OWNER
- MAC WRITE
- MIC WRITE

Additionally, in order to lock or unlock a shared memory segment in memory, a process must have the PV\_KER\_IPC\_0 privilege. A process also requires the PV\_KER\_IPC privilege to change msg qbytes of a message queue in the `msgctl` subroutine.

#### *IPC object creation and deletion:*

There are no restrictions on IPC object creation. When a process creates an IPC object, the object inherits the process SL and TL.

The IPC object's access mode must be specified by the system call that creates the object.

To delete an IPC object, the process must have DAC OWNER, MIC WRITE and MAC WRITE access to the object.

#### ***Trusted Networking:***

A set of secure networking requirements are needed for the extended security attributes of enhanced security systems. AIX Trusted Network supports several recognized secure networking standards, including U.S. DoD RFC1108 Revised Internet Protocol Security Option (RIPSO) and the Commercial Internet Protocol Security Option (CIPSO).

AIX includes Trusted Network support for both IPv4 and IPv6. When communicating with other trusted systems, the SL is encapsulated in the IP options according to CIPSO/RIPSO standards. MAC checks are enforced at the IP layer for SLs that are sent or received on the packets. The allowed label range is configured with network rules. Network rules consist of host rules and interface rules. AIX Trusted Network installs only default interface rules (one rule per configured interface). You can configure host rules to allow more granular filtering. You can use the `netrule` command to configure both host and interface rules. Operations supported by the `netrule` command include adding, deleting, listing, and querying rules.

You can also use the `tninit` command to initialize the Trusted Network subsystem and maintain the Trusted Network rules database.

#### ***Root disablement:***

The root user account is disabled on Trusted AIX systems. This is primarily to minimize the damages that can be caused to the system by a single user with all privileges.

All types of system logins as root user are disabled. Only the `su` command allows root user logins. Processes owned by root are not assigned any special privileges. The root-owned `setuid` and non-`setuid` programs work as before when invoked by authorized users. For unauthorized users, the program will run if the DAC modebits or ACLs allow execution, but the program will not be assigned any privileges, so the

program may not be able to perform privileged operations when run by unauthorized users. Therefore, it is necessary to assign proper privileges to newly installed applications if the applications are expected to perform privileged operations.

System administration tasks can be performed by users who have been assigned Information System Security Officer (ISSO), System Administrator (SA), or System Officer (SO) roles. These roles allow any user to perform system administration tasks.

**Note:** During installation of Trusted AIX the **su** attribute of the root account is set to `false`. To allow access to the root account to other administrative users, the ISSO authorized user will need to reset this attribute to `true` using the **chuser** command and assign a password to this account.

### ***Label support in auditing:***

The primary purpose of the audit subsystem is to monitor and record security-relevant events.

The information provided by the audit subsystem enables the following types of information to be recorded:

- Attempts to violate the security policy
- Successful completion of security-relevant actions

The audit subsystem provides the following capabilities:

- Determine which events to audit
- Turn auditing on and off while the system is running
- Switch audit trail files seamlessly (with no loss of information)
- Convert audit information into human-readable form
- Select and process subsets of audit information

When setting up the audit subsystem, the ISSO should understand what is to be audited, the conditions under which auditing occurs, and how to initiate and stop auditing. See *Auditing overview* for detailed information on configuring, starting and stopping, administering, and reviewing audit. See *Audit Data Structures* for additional information on auditable events and record formats.

The audit subsystem maintains its current state and is automatically restarted in that state after a power-down, system crash, power failure, or other interruption. The audit subsystem can automatically shut itself off, shut down the system, or change audit files if a condition occurs where it can no longer store audit records in the existing audit file. Audit files can be automatically switched when the file system fills to a specified level. However, in the event of a catastrophic power failure, a small number of audit records may be lost.

### ***Multilevel and partitioned directories:***

A multilevel directory is a standard directory that is assigned an SL range rather than a single SL. A partitioned directory appears as a single directory to the user. However, the files shown to the user actually reside in a hidden subdirectory of the partitioned directory.

#### *Multilevel directories:*

A multilevel directory is a standard directory that is assigned an SL range rather than a single SL.

To view the filenames in a multilevel directory, the process must be operating at a security level that is higher than the minimum SL of the directory. To create or delete the actual files, the process must be operating within the SL range of the multilevel directory.

Each file in a multilevel directory has its own SL and is protected by the standard MAC restrictions. However, any process with access to the directory is able to view the names of all objects in the directory. Thus, a process could have MAC read and write capabilities in a directory, but be unable to read and/or write some files in the directory, even though the process can view the names of all files in the directory.

*Partitioned directories:*

A partitioned directory appears as a single directory to the user. However, the files shown to the user actually reside in a hidden subdirectory of the partitioned directory.

Multilevel directories pose a security risk. A process operating at a high security level can read a file at a lower security level and then create files at the same high security level. While MAC features prevent lower-security processes from reading the new files, lower-security processes can still see the names of the new files. If the high security process gave the new files names based on the content of the original high security file, then lower-security processes could gain access to higher-security information by reading the new file names.

When a partitioned directory is created and a process addresses the directory, the system creates a hidden subdirectory with the same SL as the addressing process. If the process then creates a file, the file is actually created in the hidden subdirectory. A partitioned directory may have several such hidden subdirectories in it, but a process addressing the partitioned directory will only see the files in the hidden subdirectory with the same SL as that of the addressing process. When a process creates a child directory of a partitioned subdirectory, that child directory is a partitioned sub-subdirectory.

A partitioned directory is assigned an SL range from SYSTEM\_LOW to SYSTEM\_HIGH. Thus, any process can access the partitioned directories.

Users with **aix.mls.pdir.mkdir** authorization can create partitioned directories with the **pdmkdir** command. Empty partitioned directories can be removed with the **pdrmdir** command. The **pdset** command can be used to change a regular directory into a partitioned directory type. There is no command to change a partitioned directory into a regular directory.

Within a partitioned directory, you can link a file in one partitioned subdirectory to all other existing partitioned subdirectories with a higher SL in the same partitioned directory. This allows access to a file within a partitioned directory by all processes with access to that partitioned subdirectory or to higher-level partitioned subdirectories in the same partitioned directory. You can use the **pdlink** command for this file linking.

*Partitioned directory access modes:*

A process is assigned one of two modes on creation, real mode or virtual mode. The mode determines how the process views partitioned directories.

A real-mode process treats partitioned directories as standard multilevel directories. All partitioned subdirectories can be accessed as standard directories, subject to normal DAC, MIC, and MAC restrictions. A real-mode process can enter a partitioned directory and view all subdirectories, subject to DAC, MIC, and MAC restrictions.

A virtual-mode process never enters a partitioned directory, but is instead redirected to the partitioned subdirectory whose maximum and minimum SLs are both equal to the effective SL of the process.

A real-mode process can run a command in virtual mode with the **pdmode** command (for example, **pdmode 1s**). Similarly, a virtual-mode process can run a command in real mode, also with the **pdmode** command (for example, **pdmode -r 1s**). However, this requires **aix.mls.pdir.mode** authorization. With this

authorization, you can also switch from a shell running in virtual mode to a shell running in real mode by running `pdmode -r sh`. No authorization is required to launch a program in virtual mode while running in real mode.

*Viewing and changing directory types:*

You can use the **lstxattr** command to display the directory type as part of the `secflags` attribute. `FSF_PDIR` indicates a partitioned directory, `FSF_PSDIR` indicates a partitioned subdirectory, and `FSF_PSSDIR` indicates a partitioned sub-subdirectory. To change a regular directory type to a partitioned directory type, use the **pdset** command.

## Trusted AIX administration

Managing a Trusted AIX system involves a number of factors that are specific to Trusted AIX.

### Trusted AIX installation

Trusted AIX can be enabled only during base operating system installation using the `Security Model` option of the install menu.

The migration option for Trusted AIX is not supported. For preservation installation the file systems must be JFS2. For a promptless network install, see Table 32 for the passwords associated with default administrative users.

*Table 32. Passwords for default administrative users*

| User | Password |
|------|----------|
| isso | isso     |
| sa   | sa       |
| so   | so       |

### Run modes

Two run modes, configuration mode and operational mode, are available to allow for system configuration and maintenance and for daily operations.

When the system boots up, it initially runs in configuration mode. After initialization is complete, the run mode is changed to operational.

Configuration mode is used to maintain and recover the system. When the system is booted in single-user mode, the system is minimally configured and networking is disabled. Configuration mode is used for administration of critical, security-relevant parts of the system.

Operational mode is the standard system operating mode. The system changes to this mode after all tasks required to enter the default run level have been completed.

The system run mode can be displayed with the **getrunmode** command and can be modified with the **setrunmode** command.

### Kernel security flags

Kernel security flags are used to enable/disable certain security features such as label check enforcement, checking for integrity labels during read operations, and other purposes.

The kernel checks for kernel security flags before enforcing security checks. These flags are supported only when Trusted AIX is enabled. In the user space, these flags are stored in the ODM database. Depending upon the run mode of the system, the kernel checks for the corresponding kernel security flags.

Table 33. Kernel security flags and default values

| Kernel security flag | Enabled                                             | Disabled                                                      | Operational mode default | Configuration mode default |
|----------------------|-----------------------------------------------------|---------------------------------------------------------------|--------------------------|----------------------------|
| tinet_enabled        | Trusted network functionality available             | Trusted network functionality cannot be configured or used    | Disabled                 | Disabled                   |
| tl_write_enforced    | MIC enforced on write, delete and rename operations | Configuration set so that TLs are not used for write checks   | Enabled                  | Enabled                    |
| tl_read_enforced     | MIC enforced on read operations                     | Configuration set so that TLs are not used for read checks    | Disabled                 | Disabled                   |
| sl_enforced          | MAC enforced                                        | Configuration set so that SLs are not used for access control | Enabled                  | Disabled                   |
| trustedlib_enabled   | FSF_TLIB flag on file system objects is honored     | FSF_TLIB flags are not honored                                | Disabled                 | Disabled                   |

## Setting kernel parameters

The Trusted AIX kernel can be configured to enforce security constraints as required by site policies.

The security configuration viewed using the **getsecconf** command and can be changed using the **setsecconf** command. The configurable kernel parameters are:

- Sensitivity label enforcement
- Integrity read enforcement
- Integrity write enforcement
- Trusted Network
- Trusted library

These parameters can only be configured while the system is in the configuration run mode.

## Customizing the `/etc/security/enc/LabelEncodings` file

The labels for a system are defined in the `/etc/security/enc/LabelEncodings` file and can be customized for each site.

Labels can be customized after Trusted AIX is installed.

A Trusted AIX system has a defined SYSTEM LOW SL (SLSL) that is dominated by all other sensitivity labels on the system, and a defined SYSTEM HIGH SL (SHSL) that dominates all other sensitivity labels. Similarly, the SYSTEM LOW TL (SLTL) is dominated by all other integrity labels on the system and SYSTEM HIGH TL (SHTL) dominates all other integrity labels. These definitions take the values of the highest and lowest SLs and TLs as defined in the `/etc/security/enc/LabelEncodings` file.

When a Trusted AIX system is booted, the system labels from the `/etc/security/enc/LabelEncodings` file are downloaded to the kernel. The labels can also be downloaded to the kernel with the **setsyslab** command. The system labels as defined in the kernel can be listed with the **getsyslab** command. It is recommended that the system be rebooted after modifying the `/etc/security/enc/LabelEncodings` file.

Comments can be placed in the `/etc/security/enc/LabelEncodings` file any place where a keyword can start. Comments begin with a `*` and continue to the end of the line.

The **/etc/security/enc/LabelEncodings** file contains version information and the following mandatory sections. Each section should start with one of these section keywords followed by a colon (:).

- classifications
- information labels
- sensitivity labels
- clearances
- channels
- printer banners
- accreditation range

The **/etc/security/enc/LabelEncodings** file begins with the **VERSION** entry. This entry is a sequence of characters and can contain white spaces.

Each of the following keywords can be present in a section. These keywords terminate with a semicolon (;):

**name=*name***

Keyword to define the full name of the classification or compartment

**sname=*name***

Keyword to define to abbreviated name. Optional.

**aname=*name***

Alternate keyword for the classification. Optional.

**value=*value***

Keyword to specify the internal integer value of the classification or compartment

**compartments=*bit***

Keyword to specify which compartment bit must be 0 or 1 if the word is present in the label

### Trusted AIX enhancements to the label encoding format

The label encoding as prescribed by the Defense Intelligence Agency Document DDS-2600-6216-93 does not support the integrity labels.

By default, sensitivity labels are used as integrity labels. Trusted AIX provides support for an optional integrity labels section which can be different from the sensitivity labels sections. This provides flexibility of having different classification names and values for sensitivity and integrity labels. For example, the sensitivity labels can be prefixed with SL, and integrity labels with TL as follows:

*Table 34. Sensitivity labels classification names and values*

| <b>name</b>                 | <b>sname</b>      | <b>value</b> |
|-----------------------------|-------------------|--------------|
| name= SL IMPLEMENTATION LOW | sname= SL_IMPL_LO | value= 0     |
| name= SL UNCLASSIFIED       | sname= SL_U       | value= 20    |
| name= SL PUBLIC             | sname= SL_PUB     | value= 40    |
| name= SL SENSITIVE          | sname= SL_SEN     | value= 60    |
| name= SL RESTRICTED         | sname= SL_RES     | value= 80    |
| name= SL CONFIDENTIAL       | sname= SL_CON     | value= 100   |
| name= SL SECRET             | sname= SL_SEC     | value= 120   |
| name= SL TOP SECRET         | sname= SL_TS      | value= 140   |

Table 35. Integrity labels classification names and values

| name                        | sname             | value      |
|-----------------------------|-------------------|------------|
| name= TL IMPLEMENTATION LOW | sname= TL_IMPL_LO | value= 0   |
| name= TL UNCLASSIFIED       | sname= TL_U       | value= 20  |
| name= TL PUBLIC             | sname= TL_PUB     | value= 40  |
| name= TL SENSITIVE          | sname= TL_SEN     | value= 60  |
| name= TL RESTRICTED         | sname= TL_RES     | value= 80  |
| name= TL CONFIDENTIAL       | sname= TL_CON     | value= 100 |
| name= TL SECRET             | sname= TL_SEC     | value= 120 |
| name= TL TOP SECRET         | sname= TL_TS      | value= 140 |

The following rules apply to the integrity labels section:

- The "INTEGRITY LABELS" section should be added only after the "NAME INFORMATION LABELS" section. In cases where the administrator has not defined the optional "NAME INFORMATION LABELS" section, the "INTEGRITY LABELS" section should be added next to the "ACCREDITATION RANGE" section.
- There should be only one "INTEGRITY LABELS" section in the label encoding file. The same section applies to both objects and subjects.
- The new "INTEGRITY LABELS" section is an optional section. In case this section is not present, the classifications as given in the mandatory "CLASSIFICATIONS" section should be used.
- The "INTEGRITY LABELS" section would be similar to the "CLASSIFICATIONS" section. It would contain the following keywords: "name=", "sname=", "aname=", and "value=". The keywords "initial compartments=" and "initial markings=", which are part of "CLASSIFICATIONS" section, would not be valid in "INTEGRITY LABELS" section.
- The data range for "value=" would be the same as that for the "CLASSIFICATIONS" section – minimum of 0 to maximum of 32,000.

## Starting up the system

System security is automatically invoked during the system startup sequence. You should verify that the security parameters displayed during the startup sequence are correct for the system.

### **Configuration startup mode:**

Configuration mode is used to maintain and recover the system.

When the system is booted in single-user mode, the system is minimally configured and networking is disabled.

### **Operational startup mode:**

Operational mode is used for daily operation.

Normally, the system should be booted directly into multiuser mode. If the boot authorization program receives a valid username and password, the system enters operational mode, a console login authentication screen is displayed, and valid users can then log in.

Security mechanisms such as sensitivity labels, discretionary access controls, mandatory access controls, privilege checks, identification and authentication, and authorizations, are active in both configuration mode and operational modes, as dictated by the relevant security configuration flags. For more information, see the **getsecconf** command.

It is recommended that the system be operated only in operational mode to ensure that all expected system functionality is available.

### ***Boot process:***

New boot scripts added to the `/etc/inittab` file on Trusted AIX systems. The new boot scripts are `rc.mls.boot`, `rc.mls.net`, and `rc.mls`, and are executed in that order.

The steps executed in the `rc.mls.boot` script are:

1. An interactive integrity check is run to prompt the user for information on how to handle each discrepancy (using the `trustchk` command)
2. Set the configuration mode kernel security flags (using the `setsecconf` command)
3. Set the system labels (Minimum and Maximum Sensitivity Labels and Integrity Labels)
4. The configuration mode kernel security flags are displayed on the screen

The steps executed in the `rc.mls.net` script are:

1. Initialize the Trusted AIX AIX sub-system.
2. If the `/etc/security/rules.int` file exists, it will load the rules database into the kernel.

The steps executed in the `rc.mls` script are:

1. Initialize the Trusted AIX AIX sub-system.
2. If the `/etc/security/rules.int` file exists, it will load the rules database into the kernel.

**Note:** Any change to the boot scripts can result in a system malfunction.

### ***Customizing system startup:***

Although not recommended, boot authentication and system integrity checking at system startup can be disabled.

An operator must be physically present at the system console to start up the system unless boot authentication and system integrity checking are disabled.

### ***Disabling BOOT authentication:***

BOOT authentication can be disabled by running the `rmitab bootauth` command or using the SMIT menu.

### ***Disabling system integrity check:***

You can disable the automatic system boot integrity check by removing the `trustchk` line from the `rc.mls.boot` script.

## **Shutting down the system**

System shutdown is a privileged operation and is protected by the `aix.system.boot.shutdown` authorization.

Any user with the `S0` role or another role that has this authorization can shut down the system.

## **Trusted recovery**

There may be times when the system powers down in an unclean state. This can be the result of a power outage, an accidental power down, or a hardware failure. Trusted AIX can recover from these circumstances without special reboot procedures.



When the system reboots, all protection mechanisms are active, regardless of how the system was powered down. During the system startup procedure, all file systems are automatically checked for damage before users can log on. The startup scripts run the **fsck** command to secure or make inaccessible to unauthorized users any damaged or compromised files.

The **trustchk** command reports any inconsistencies in the security attributes of files or directories and interactively prompts the user to repair these attributes. The **trustchk** command should be run whenever there is a possibility that the integrity of the file system may have been compromised. See the **trustchk** command for more information.

## Login

Every Trusted AIX user should have the proper sensitivity and integrity clearances assigned so that they can log in to the system.

The user's clearances are defined as user attributes in the **/etc/security/user** file. The `minsl` and `maxsl` attributes define the sensitivity clearance of the user. The `mintl` and `maxtl` attributes define the integrity clearance for the user. The `defsl` and `deftl` attributes define the effective sensitivity and integrity levels of the user at login.

User clearance attributes can be modified with the `chuser` and `chsec` commands and can be listed with the `lsuser` and `lssec` commands.

Users can list their own labels but cannot change them. To list the clearance levels of other users, a user must have the `aix.mls.clear.read` authorization. To modify clearances, a user must have the `aix.mls.clear.write` authorization.

To log in, all of the following dominance rules must be true:

- The `minsl` value must be dominated by the `defsl` value
- The `defsl` value must be dominated by the `maxsl` value
- The `mintl` value must be dominated by the `deftl` value
- The `deftl` value must be dominated by the `maxtl` value

You can specify the desired effective sensitivity and integrity levels during login using the **-e** and **-t** options of the **login** command. See the **login** command for more information.

To log in at a sensitivity level that is not in the accreditation range of the system, you must have the `aix.mls.label.outsideaccred` authorization.

Trusted AIX does not allow system users (users with a `uid` less than 128) to log in.

## Reasons for login failures

A login attempt can fail for a number of reasons.

A login attempt will fail if any of the following are true:

- An invalid login ID was entered
- An invalid password was entered
- The account is marked as locked because the number of previous bad login attempts for this account exceeds the system limit
- The login port is marked as locked because the number of previous bad login attempts for the port exceeds the system limit
- The login ID does not have a valid clearance
- The specified label (or the default sensitivity or integrity label for the login ID if no label was specified) is not valid, is not within the clearance for the login ID, is not within the clearance of the login device, or is not within the accreditation range of the system

- The user does not have DAC access to the pathname of the login shell program, or the user account does not have DAC exec access to the login shell program
- The user does not have MAC or MIC read access to the pathname of the login shell program or does not have MAC or MIC read access to the login shell program
- The uid of the login ID was less than 128

### **Switching user with the su command**

On a Trusted AIX system, when the **su** command with the **-** option is invoked, the current user's clearances must dominate the new user's clearance level.

The following conditions must be met for both sensitivity and integrity labels:

- the current user's maximum clearance must dominate the new user's maximum clearance.
- the new user's minimum clearance must dominate the current user's minimum clearance
- the current user's effective clearance must be dominated by the new user maximum clearance and must dominate the new user's minimum clearance.

### **User security responsibilities**

There are certain responsibilities which users must be aware of, understand, and follow. Users must keep passwords private, report changes in their user status, report suspected security violations, and more.

### **Passwords**

Passwords should be memorized and should not be written down on any medium. If a password is obtained by another user, this can compromise the security of information on the system.

The most obvious threat to password security is the compromise of passwords. The simplest way to protect an account from an unauthorized attack by a user who may have discovered a password is to periodically change the password. Passwords should be changed frequently enough to reduce the probability of compromise during the lifetime of the individual password. The longer any single password is used, the more opportunities there are for compromise.

If users are allowed to select their own passwords, the new password must be at least six characters long and must contain at least two alphabetic characters and one numeric character. The password should not reflect any personal or professional aspect of the user (for example, friends, user's name, pet's name, or job title) and should not be a common word that might be found in a dictionary. Password-guessing schemes often scan one or more dictionaries and a substantial list of personal items, such as the user's name, the names of children or pets, and birthdays.

Passwords can have a finite lifetime, determined by the ISSO. If a password has expired and the user attempts to log in, the user is notified that the password must be changed and the user is allowed to log in unless the password is changed. It is recommended that user passwords be changed more frequently than the specified password lifetime. If there is any suspicion that a user's password has been compromised, the password should be changed immediately.

### **Leaving your system unattended**

You should never leave a system unattended while any user is logged into an active session. If you must be away from the machine for even a short period of time, it is strongly recommended that you log off the system before leaving.

### **Secure system management**

Management of a secure computer system involves the creation and enforcement of security policies and regular system monitoring.

The following list should serve as a starting point for the development of a secure facilities management policy for your site:

- The maximum security level in the system's accreditation range should not be greater than the maximum security level for the site in which the system is located.
- The system hardware should be in a secure location. The most secure locations are generally interior rooms that are not on the ground floor.
- Physical access to the system hardware should be restricted, monitored, and documented.
- System backups and archival media should be stored in a secure location, separate from the system hardware site. Physical access to this location should be restricted in the same manner as access to the system hardware.
- Access to operating manuals and administrative documentation should be restricted to a valid need-to-know basis.
- System reboots, power failures, and shutdowns should be recorded. File system damage should be documented and all affected files should be analyzed for potential security policy violations.
- Installation of new programs, whether imported or created, should be restricted and monitored. New programs should be carefully scrutinized and tested before being run.
- Unusual or unexpected behavior of any system software should be documented and reported, and the cause of the behavior determined.
- Whenever possible, at least two people should administer a system. One person should have the `isso` role and the other should have the `sa` role.
- The `PV_ROOT` privilege should not be used. To administer the system, the execution of privileged programs by `ISSO`, `SA`, or `SO` users should be sufficient.
- Audit information should be collected in logs and reviewed regularly. Irregular or unusual events should be noted and their cause investigated.
- The number of logins with the `isso`, `sa`, and `so` roles should be minimized.
- The number of `setuid` and `setgid` programs should be minimized and should only be used in protected subsystems.
- Privileges assigned to new programs should be determined and minimized by reviewing those assigned to existing programs.
- Security attributes of files and directories should be verified regularly with the **`trustchk`** command.
- All passwords should contain at least 8 characters. This should be regularly verified by an `ISSO` user.
- All users should have a valid default login shell. This should be regularly verified by an `SA` user.
- The user IDs of normal users should not be system IDs. This should be regularly verified by an `SA` user. A system id is one which has a `uid` lesser than 128.

### ***System configuration:***

Certain steps must be taken by the `ISSO` and `SA` to properly configure the system. The `ISSO` is primarily responsible for managing security, while the `SA` is primarily responsible for daily administration.

The `ISSO` performs the following tasks:

- Installs and configures the basic security functionality, including system auditing, accounting, and security for allocatable devices.
- Edits the system startup scripts in the `/etc/rc.mls` and `/etc/rc.mls.boot` files to meet the site security policy.

**Note:** Any changes made to the system startup scripts are not part of the evaluated configuration and must be addressed before accrediting the system.

- Configures the system-wide login parameters.
- Configures the system-wide password parameters.

- Configures the SL range for tty devices that allow users to log in to the SL ranges specified for the tty port. See the **chsec** command for more information.
- Configures system device SLs for tape drives and floppy disk drives. See the **setsecattr** command for more information.
- Configures the site-configurable security features of the system.

**Note:** Any changes made to the configurable security features are not part of the evaluated configuration and must be addressed before accrediting the system. Changing the default configuration settings can result in the system operating in a less-secure mode.

- Configures the trusted security database for trusted boot and trusted recovery. See the **trustchk** command for more information.
- Configures the user groups on the system.

The ISSO and SA work together to configure printers. The SA configures the printers for the system and the ISSO configures the SL range for the printers.

### ***Network configuration:***

The ISSO is primarily responsible for network security and the SA is primarily responsible for daily network administration. The ISSO and the SA work together to properly configure the network.

Network security is configured with default settings during Trusted AIX installation. It can also pass sensitivity labels to other Trusted AIX hosts on the network. The ISSO installs and configures the basic network functionality provided with the system. The ISSO configures the network tables and then runs the **tninit** command to save the databases.

### ***Network access:***

When connecting to a non-Trusted AIX system via a network or to a Trusted AIX system that not using the Trusted Networking feature, some security attributes may not be transmitted by the non-Trusted AIX system. In this case, the Trusted AIX system applies default security mechanisms. The default security mechanisms are established by a system administrator.

### ***User account configuration:***

The ISSO and SA work together to configure user accounts on the system. The ISSO is primarily responsible for managing security-related user attributes and the SA is primarily responsible for other user attributes.

The ISSO performs the following tasks for each user:

- Configures clearance. See the **chsec** and **chuser** commands for more information
- Configures roles and authorizations
- Configures user groups
- Sets the home directory clearance level. See the **settxattr** command for more information
- Sets the password
- Sets the audit masks

The SA performs the following tasks:

- Configures user accounts
- Informs the ISSO of new user accounts that require security attributes

### ***Filesystem configuration:***

Most file systems are supported on Trusted AIX, however, the support for Trusted AIX security related extended attributes on file system objects is available only on JFS2 with EAv2.

A JFS2 with EAv1 filesystem is converted to EAv2 when it is mounted on a Trusted AIX system. Files on these JFS2 filesystems do not have security attributes. The system uses the default SYSTEM\_LOW attributes to access these files. The security attributes can be set on the files by the **setxattr** command.

In a network environment, a directory on one system can be marked as shared, meaning that the directory can be mounted and accessed on other systems in the network as if it were the root directory of a filesystem on a local disk partition.

A file system can be either a multilevel filesystem (MLFS) or a single-level filesystem (SLFS). Each file object in MLFS has its own labels, whereas all objects in SLFS have the same labels as the mount point. SLFS does not support multilevel directories and partitioned directories.

#### *Filesystem access:*

When a process attempts to access a filesystem object, the system verifies access to each pathname component.

If a process does not have search access to all of the directories in the pathname, this process cannot access the object. When a relative pathname is used, access to the current directory is checked whether or not the current directory is explicitly referenced using a period (.) at the beginning of the pathname.

#### ***Trusted Network management:***

There are a number of considerations for managing a Trusted Network, including configuration and the configuration database, netrule syntax and rule specification, Trusted Network flags, and RIPSO/CIPSO options.

#### *Default configuration warning:*

The networking capabilities of AIX Trusted Network have been carefully designed to allow any conceivably desired configuration. However, changing the configuration from the default values without understanding AIX Trusted Network can be dangerous.

It is possible, by improperly configuring a machine, to automatically downgrade, upgrade, or remove security information altogether. Therefore, you should not change the default values in the networking tables unless you are familiar with AIX Trusted Network.

#### *AIX Trusted Network configuration database:*

The network configuration at boot time is established by the **rules.host** and **rules.int** files.

After a default Trusted AIX installation, there are no host rules or rule files. The **netrule** command can be used with the **-u** flag to save the new or updated rules to files. The files are binary databases that can be manipulated with the **tninit** command. A user must have the `aix.mls.network.init` authorization to use the **tninit** command.

#### *Displaying the AIX Trusted Network rules database:*

The contents of an AIX Trusted Network rules database set can be displayed with the **disp** action of the **tninit** command.

Enter the following command to append the extensions of **.host** and **.int** to *filename* to generate the filenames of the host rules database and the interface rules database. The contents of both files will be sent to the standard out stream in human-readable form.

```
tninit disp filename
```

Enter the following command to display the boot default configuration:

```
tninit disp /etc/security/rules
```

#### *Loading the AIX Trusted Network rules database:*

The **tninit** command reads a set of AIX Trusted Network rules databases and loads them into the kernel to become the active set. The filenames of the host and interface accreditation tables are specified in the same method as the **tninit disp** action.

The optional **-m** flag specifies that the system should maintain the existing host rules. If the **-m** flag is not specified, all existing host rules are removed before the new active set is loaded. If the **-m** flag is specified, the existing and new host rule sets are aggregated, with the new rules overwriting the existing rules if there is a conflict. All interface rules are overwritten whether or not the **-m** flag is specified.

The following command loads new rules while maintaining the old rules set:

```
tninit -m load /dir/dir/filename
```

This command used the file specified by the *filename* parameter and appends the **.host** and **.int** extensions to create the two files that comprise the database.

#### *Saving the AIX Trusted Network rules database:*

Similar semantics are used for loading and saving the rules database.

Any specified filename is appended with **.int** and **.host** to create the two files used to store the database. The **tninit** command's save action stores all of the rules that are currently active in the kernel.

To create the default rule set, you must use the **netrule** command to tailor the kernel rules to fit the desired site security policy, and then run the **tninit** command. The following command creates the **/etc/security/rules.int** and **/etc/security/rules.host** files:

```
tninit save /etc/security/rules
```

#### *AIX Trusted Network kernel configuration:*

You can use the **netrule** command to completely configure the kernel's AIX Trusted Network rule set to fit the site's security policy if you have the `aix.mls.network.config` authorization.

The **netrule** command can be used to manipulate both host and network interface rules in the kernel. See the **netrule** command for more information.

Each interface in a system must have a rule associated with it. If you attempt to delete an interface rule, it reverts to its default state. If you add another interface rule, the new interface rule overwrites the current rule. The default interface rule can be viewed by querying the interface rule with the interface name as "default." For example: `# netrule iq default`

#### *netrule syntax:*

There are host and interface syntax rules for the **netrule** command.

The **netrule** command has the following syntax rules when used for hosts:

**netrule h l [ i | o | io ]**

**netrule h q { i | o } src\_host\_rule\_specification dst\_host\_rule\_specification**

**netrule h - [ { i | o } [ u ] [ src\_host\_rule\_specification dst\_host\_rule\_specification ]**

**netrule h + { i | o } [ u ] src\_host\_rule\_specification dst\_host\_rule\_specification [ flags ] [ RIPSOCIPSO\_options ] security**

The **netrule** command has the following syntax rules when used for interfaces:

**netrule i l**

**netrule i q interface**

**netrule i + [ u ] interface [ flags ] [ RIPSOCIPSO\_options ] security**

The first element, h or i, indicates a host or network interface operation.

The desired action is listed next. There are four distinct actions available:

- l** List all rules
- q** Query a particular rule
- Remove a host rule or revert an interface rule to its default state
- +** Add or overwrite a rule

The third element in host rules identifies the rule type. For host rules, there is a distinction between incoming and outgoing rules. The in rules apply to all incoming packets while out rules apply to all outgoing packets; i indicates an in rule, o indicates an out rule, and, when applicable, io or nothing indicates both in and out rules. If the last element u is specified when adding or removing a host or interface rule, the **/etc/security/rules.host** and **/etc/security/rules.int** files are updated after the host or interface rule is successfully added or removed.

*AIX Trusted Network rule specification:*

Interface rules require that you enter the name of the network interface. Host rules are much more flexible and therefore require a more complex rule specification.

To specify an interface, enter the name of the network interface the rule should apply to. Network interface names are names such en0. You can use the **ifconfig -a** command to see the network interface names. You must specify a particular interface by name only. You cannot specify a port, protocol, or subnet mask.

Host rules require a more complex rule specification. The AIX Trusted Network system uses the most specific applicable rule. For example, a site policy can be configured so that a host rule with a mask of 24 applies to all hosts on a subnet, but a more specific rule can apply to a single host on the net, and this host uses the more-specific rule. Another more specific rule can also apply to one specific TCP port on this host. The flexibility of AIX Trusted Network configuration gives you the ability to implement whatever site security policy is needed for the application. The exact syntax is:

*source\_host [ /mask ] [ = proto ] [ :start\_port\_range [ :end\_port\_range ] ]*

*destination\_host [ /mask ] [ = proto ] [ :start\_port\_range [ :end\_port\_range ] ]*

*source\_host*

The host name, IPv4 address, or IPv6 address of the source host.

*destination\_host*

The host name, IPv4 address, or IPv6 address of the destination host.

*mask* The subnet mask. The number indicates how many bits from the MSB are relevant. When an IPv4 address/subnet pair is written *a.b.c.d/e*, *e* is a number from 0 to 32. This number specifies the number of ones at the beginning of the subnet mask. For example, for an IPv4 address, /24 specifies a netmask of 255.255.255.0, which, when seen as 32 bits, is 11111111.11111111.11111111.00000000. This is 24 ones followed by eight zeros.

*proto* The protocol number or name as recorded in the **/etc/protocols** file (for example, =tcp).

*start\_port\_range*

Either the TCP or UDP port to which the rule applies, or the beginning of the range if the rule applies to a range of ports. This can be either the port number or the name of the UDP or TCP service as recorded in the **/etc/services** file.

*end\_port\_range*

The upper bound of the port range.

*AIX Trusted Network flag description:*

The AIX Trusted Network system has two flag clusters. If these are not specified, the default values are used.

The **-d** and **-r** flags are used as follows:

**-d drop**

*drop* AIX Trusted Network can be configured to drop all packets

- r** Drop all packets on this interface
- n** Do not automatically drop all packets on this interface (interface default)
- i** Use interface default (host default, host only)

**-f rflag: tflag**

*rflag* Security option requirement on incoming (received) packets

- r** RIPS0 only
- c** CIPS0 only
- e** Either CIPS0 or RIPS0
- n** Neither CIPS0 or RIPS0 (system default)
- a** No restrictions
- i** Use interface/system default (default)

*tflag* Security option handling on outgoing (transmitted) packets

- r** RIPS0 placed on all outgoing packet IP headers
- c** CIPS0 placed on all outgoing packet IP headers
- i** Use interface default (host default, host only)

*RIPS0/CIPS0 options:*

The AIX Trusted Network subsystem supports options for the configuration of CIPS0 and RIPS0 packet labeling.

**-rpafs=PAF\_field [, PAF\_field ... ]**



Specifies each *PAF\_field* that is accepted when IPSO packets are received. There can be up to 256 of these fields.

**-epaf=PAF\_field**

Specifies the *PAF\_field* that is attached to error responses when error packets are sent using IPSO on transmitted packets.

**-tpaf=PAF\_field**

Specifies the *PAF\_field* that is applied to outgoing packets when IPSO is used on transmitted packets.

*PAF\_field*:**NONE** | *PAF* [ + *PAF* ... ]

A *PAF\_field* is a collection of *PAFs*. There are five individual *PAFs* that can be included in a single *PAF\_field*. These are **GENSER**, **SIOP-ESI**, **SCI**, **NSA**, and **DOE**. A *PAF\_field* is a combinations of these values separated by a plus sign (+). For example a *PAF\_field* containing both **GENSER** and **SCI** is represented as **GENSER+SCI**. The special *PAF\_field* **NONE** can be used; this specifies the *PAF\_field* without any *PAFs* set.

**-DOI=doi**

Specifies the domain of interpretation for CIPSO packets. Incoming CIPSO packets must have this **DOI** and outgoing CIPSO packets will be labeled with this **DOI**.

**-tags=tag[,tag ...]**

*tag*=**1** | **2** | **5**

Specifies the set of tags that are accepted and available to be transmitted by CIPSO options. This is a combination of **1**, **2**, and **5** separated by commas. For example **1,2** would enable tags **1** and **2**.

*AIX Trusted Network security policy:*

The minimum SL allowed, the maximum SL allowed, and the default SL must be specified.

The implicit or default SL is applied to all packets that do not carry any information about their own SL. The levels are entered in the following syntax:

**+min +max +default**

Any label that is valid according to the label encodings file can be used. Quotes are not required for labels that include spaces.

*netrule examples:*

The following are examples of the **netrule** command.

Enter the following to configure **en0** to pass no security options and to allow all packets through:

```
netrule i+ en0 +impl_lo +ts all +impl_lo
```

Enter the following to configure the host **185.0.0.62** to accept only CIPSO packets within the range of **CONFIDENTIAL A** to **TOP SECRET ALL**:

```
netrule h+i 192.168.0.0 /24 185.0.0.62 -fc:c +confidential a +top secret all +confidential a
```

Enter the following to drop all telnet packets from a subnet:

```
netrule h+i 192.168.0.0 /24 =tcp :telnet 192.0.0.5 -dr +impl_lo +impl_lo +impl_lo
```

See the **netrule** command for more information and examples.

### ***Managing user accounts:***

Identification and authentication (I&A) information about each user is protected and is used to uniquely identify the user and verify the user's access permissions within the system.

User identity information includes the user's name, login ID text name, user ID, group ID, home directory, password, password aging parameters, shell, clearances, authorizations, and audit mask. Most user-related information is stored in the following files:

#### ***/etc/passwd***

User names, user IDs, primary group assignments, and home directories

#### ***/etc/group***

Secondary group assignments and home directories

#### ***/etc/security/passwd***

User passwords in encrypted form

#### ***/etc/security/user***

Login restrictions, password parameters (such as minimum length), umask, etc.

The ***/etc/security/passwd*** and ***/etc/security/user*** files are not readable by normal users. The ***/etc/security/passwd*** file is protected with no discretionary access bits turned on and an SL of SYSTEM\_HIGH. Preventing normal users from reading the encrypted password eliminates sequential encryption/comparison routines that attempt to match the encrypted password.

Authorized users can edit these files directly, but it is often more convenient to use the **smit** command to edit user parameters. The **smit** command invokes the System Management Interface Tool (SMIT), which displays menus with choices for system management tasks such as user maintenance.

### *User and group IDs:*

There are two classes of user IDs: system IDs and normal user IDs. System IDs are reserved for ownership of protected subsystems and special system administration functions. Normal user IDs are assigned to individuals who use the system interactively.

Each user has a unique user ID used to identify the user on the system. Each user can also be assigned one or more group IDs. Group IDs are shared by users in the same group and are not necessarily unique. There are range limits on the numeric values used for IDs. The following table defines the ID range limits. The values have been defined to allow for a sufficient number of system and normal user and group IDs.

#### **System user ID**

0 to 127

#### **Normal user ID**

128 to MAXUID

#### **Normal group ID**

0 to MAXUID-1

The MAXUID value is defined in the ***/usr/include/sys/param.h*** file

Care should be taken when assigning user ID values for new users. If a normal user is inadvertently assigned a user ID value less than 128, the user will not be able to log onto the system.

User ID values should not be reused. When a user is deleted, it is recommended that the entries remain in the **/etc/passwd** and **/etc/security/passwd** files and the account be locked. You can do this with the **smit** command. This prevents a user from logging in and the ID from being reused. Not reusing the ID prevents a new user from accessing files that belong to the previous user and that may not have been removed. This also allows the audit trail to be reconstructed with no ambiguity.

The **/etc/passwd**, **/etc/security/passwd**, and **/etc/group** files can be managed with the **mkuser**, **chuser**, **rmuser**, **pwdadm**, and **passwd** commands. These commands enforce all of the above precautions as well as all other system security considerations. The **mkuser** command can only add normal users to the system.

**Note:** Carefully enforce the following standards:

- Never reassign a previous used user ID to a new user
- Never assign duplicate user IDs
- Never assign a system ID to a normal user
- Never assign MAXUID as a user ID or group ID

*Passwords:*

A password is a character string that is associated with a user and is used to authenticate the user at the start of a session.

The password is stored in encrypted form in the shadow file. The unencrypted password is not stored anywhere on the system.

**Note:** The passwords for role users are extremely important to the security of a system and should be protected at all times.

*Password aging:*

Users can change their passwords as long as password aging criteria are satisfied.

Password aging requires users to change their password if the password has existed on the system for a defined time period. Password aging includes a minimum age and a maximum age time period. A password cannot be changed before the passage of this minimum age time period. The password must be changed after the maximum age time period.

Password aging parameters can be set in the **/etc/security/user** file. The following parameters are related to password aging:

**maxage**

Maximum number of weeks a password is valid

**maxexpired**

Maximum number of weeks after maxage that an expired password can be changed by a user

**minage**

Minimum number of weeks between password changes

**minlen**

Minimum length of a password

Other parameters can be set to specify the characters that are allowed in a password. See the **passwd** command for a complete list of password parameters.

*Shell:*

While working in an application, such as a word processor or a spreadsheet, users do not generally need to interact directly with the operating system, since the application manages that interaction. However, some users need to interact directly with the operating system, without another application's interface.

When direct interaction with the operating system is needed, users must use a shell program. A shell program allows users to enter AIX commands and directly access files and directories and perform other operations. Every user must have a default shell program specified in their **/etc/passwd** file. The user's default shell program (such as **/bin/sh**, **/bin/csh**, or **/bin/ksh**) is run by the **login** or **xterm** command when the user needs to use a shell.

#### *Login effective SL and TL:*

Users are assigned a default login SL and TL. The default login SL and TL are the effective SL and effective TL of the user's process after a successful login.

If a user does not want to log in at their default login SL, they can choose a different SL at login time by using the **-e** option of the **login** command. The SL supplied by the user must be dominated by the user's clearance and contained in the system accreditation range. The TL can be specified by the user at login time by using the **-t** option of the **login** command.

The default login SL and TL are defined in the **/etc/security/user** file, along with the username and clearance for each user. The effective SL of the user must be lie between the tty SL range as specified in the **/etc/security/login.cfg** file. The user's effective SL must be dominated by the tty's maximum SL and dominate the minimum SL. The effective TL of the user must be same as the tty's TL.

#### *Clearances:*

A user's process shell is assigned six labels during login.

The effective SL is used by the system in MAC checks. The minimum SL clearance and maximum SL clearance limit the effective SL; the effective SL cannot dominate the maximum SL clearance, and it must dominate the minimum SL. The effective TL is used by the system in MIC checks. The minimum TL clearance and maximum TL clearance limit the effective TL; the effective TL cannot dominate the maximum TL clearance, and it must dominate the minimum TL.

An ISSO-authorized user can modify any user's SL clearance, TL clearance, default longin SL, and default login TL. These values are defined in the **/etc/security/user** file.

#### *Division of responsibility for user information:*

A single user cannot add a user to the system. Users are added to the system by the combined actions of SA- and ISSO-authorized users.

An SA-authorized user can add non-security related user information, which includes the user's name, user ID, group ID, login ID text name, shell, and home directory. An ISSO-authorized user can add security-related user information, which includes the user's password, clearance, audit mask, and roles. The requirement for two people to add a user prevents a single user with authorization from granting system-wide authorization to any other user.

#### **Enhanced auditing:**

Trusted AIX has enhanced the auditing subsystem to capture additional security details.

#### *New audit record fields:*

The following fields have been added to all of the AIX audit records for Trusted AIX. These new fields can be used with the **auditselect** command as select criteria.

- Roles of the audited process
- Effective TL of the audited process or object
- Effective SL of the audited process or object
- Effective privileges of the audited process

Trusted AIX also audits the following security attributes in some audit trails:

- TL of the audited process or object
- SL of the audited process or object
- Trusted AIX-related security flags

You can display these new security attributes with the **auditpr -v** command.

#### *Audit ranges:*

Trusted AIX includes a mechanism that allows administrators to specify a set of auditing ranges based on the TL and/or SL of the audited processes or objects. All objects and subjects whose TL or SL is out of the auditing ranges are ignored.

To set the audit ranges for processes and objects, add a **war** stanza in the **/etc/security/audit/config** file:

war:

```
obj_min_sl = "impl_lo a,b"
obj_max_sl = "TS a,c"
sub_min_sl = "impl_lo a,b"
sub_max_sl = "TS a,c"
obj_min_tl = impl_lo
obj_max_tl = TS
sub_min_tl = impl_lo
sub_max_tl = TS
```

The **obj\_min\_sl** and **obj\_max\_sl** define the SL audit range for objects. The **sub\_min\_sl** and **sub\_max\_sl** define the SL audit range for subjects (processes). The **obj\_min\_tl** and **obj\_max\_tl** define the TL audit range for objects. The **sub\_min\_tl** and **sub\_max\_tl** define the TL audit range for subjects (processes).

The **war** stanza is read by the **audit start** command and is uploaded to kernel before the audit subsystem is started. If the **war** stanza is omitted, the current audit ranges in the kernel are removed. The kernel does not perform any TL or SL audit range checks if there is no TL SL audit range in the kernel.

#### *Trusted AIX kernel flag:*

When a system is configured as a Trusted AIX system at install time, a global kernel flag is enabled in the **\_system\_configuration** variable. The **\_\_MLS\_KERNEL()** macro is provided in the kernel to determine whether the system is configured as a Trusted AIX system. This macro can be called by user-space applications or kernel routines. A return value of **1** from the **\_\_MLS\_KERNEL()** macro indicates that the system is configured as Trusted AIX. Any other return value indicates that the system is not configured as a Trusted AIX system.

#### *Updating existing programs:*

Existing privileged or trusted programs generally function correctly on a trusted system without change.

However, certain changes can be made to enhance the level of trust and/or upward compatibility of these programs. Many of the recommendations for creating new programs also apply to updating existing programs. The following recommendations particularly apply:

- Programs that test to determine whether they are privileged processes (that is, whether the effective user ID is 0) should be modified in accordance with the guidelines in Direct Privilege Checking
- Code that manipulates the standard UNIX system permission bits (the mode bits) should be changed to reflect the possible existence of ACLs
- Code that used to run as setuid-to-root should be examined for the use of privileges and should have the appropriate privileges assigned

### ***Backup and restore:***

Import and export of data on Trusted AIX systems uses trusted versions of the **backup** and **restore** commands.

The **backup** and **restore** commands have been extended to handle labels. These extensions are transparent to the user and, aside from the labeling extensions, these commands function identically to the standard AIX **backup** and **restore** commands. To disable the backup or restore of the extended security information, the **-O** flag can be used.

The import/export system is protected by a combination of privilege and authorization mechanisms.

### ***cron restrictions:***

The **cron** command is disabled and will not run any jobs when the system is in configuration mode. If the system is in operational mode, the **cron** command runs jobs at the sensitivity label at which the job was submitted and the user's default integrity label.

There are restrictions such as the user's minimum clearance and maximum clearance. Depending on which is more recent, the clearance is taken from either the settings of the time that the job was submitted or the last time the **cron** command restarted. Only an SA user can administer the **cron** command.

### ***Mounting and accessing filesystems:***

Trusted AIX supports labeling (SLs, and TLs) on JFS2 with EAv2 file systems. An SA or SO can mount a file system that does not support labeling (CDFS or HSFS) if necessary. In this case, all of the files on the mounted file system do not have individual SLs, TLs, or FSFs, but instead inherit the security attributes of the mount point.

## **Trusted AIX system management**

Guidelines for proper management of a Trusted AIX system must be followed to ensure system security.

Trusted AIX system management is performed by certain users whose accounts are associated with administrative roles. These users are called the Information System Security Officer (ISSO), the System Administrator (SA), and the System Officer (SO), and each of these users has authorizations that allow them to perform a specific subset of administrative tasks. These users are associated with the system defined roles `isso`, `sa`, and `so`, respectively. The terms ISSO, SA, and SO are used to refer to users having the `isso`, `sa`, and `so` roles, respectively. Some administrative duties can only be carried out by two of the three system managers working together, because one manager acting alone does not possess sufficient authorizations to complete these duties. For example, when adding a new user to the system, only the SA can add a new user account and only the ISSO can establish the user's password, clearance, and audit mask. This division of labor is known as the two-man rule.

**Note:** The effectiveness of the two-man rule depends on the authorizations that are assigned to the administrative roles. Associating more authorizations to the administrative roles than are needed can make the system susceptible to insider attacks. See RBAC for more information on associating authorizations to roles.

The system defined roles `isso`, `sa`, and `so` are associated with the following Trusted AIX authorizations by default. Proper care should be taken if these associations are changed as this could make the system vulnerable.

Table 36. Roles and authorizations

| <b>isso</b>            | <b>sa</b>       | <b>so</b>     |
|------------------------|-----------------|---------------|
|                        |                 | aix.mls.login |
|                        | aix.mls.printer |               |
| aix.mls.network.config |                 |               |
| aix.mls.network.init   |                 |               |
| aix.mls.network.config |                 |               |
| aix.mls.login          |                 |               |
| aix.mls.pdir           |                 |               |
| aix.mls.system.label   |                 |               |
| aix.mls.tpath          |                 |               |
| aix.mls.label          |                 |               |
| aix.mls.system.config  |                 |               |
| aix.mls.proc           |                 |               |
| aix.mls.clear          |                 |               |
| aix.mls.lef            |                 |               |
| aix.mls.stat           |                 |               |
| aix.mls.printer        |                 |               |

### **Managing the system for Information System Security Officers:**

A Trusted AIX system is managed by the coordinated activities of ISSO, SA, and SO users.

During Trusted AIX installation, three default user accounts of **isso**, **sa**, and **so** are created (if these accounts are not already present in the case of migration from regular AIX to Trusted AIX). These users are associated with the `isso`, `sa` and `so` respectively.

**Note:** The default accounts are only intended for the initial setup and configuration of a Trusted AIX system. It is recommended that these roles be assigned to other regular users. After these roles have been assigned to other users, the default user account can be removed. See *Installation and migration* for more information on Trusted AIX installation.

### **ISSO activities**

The primary responsibility of the Information System Security Officer (ISSO) is security administration of the system. Only a user with ISSO authorization can perform ISSO activities. These activities include:

- Planning, implementing, and enforcing site security policy
- Establishing system-wide defaults for user clearance, authorizations, privileges, login controls, and password parameters
- Setting up user authentication profiles reflecting the level of trust placed in users when user accounts are created by the system administrator
- Assigning security attributes, SLs, and TLs to devices such as terminals, printers, removable disk drives, and magnetic tape drives
- Assigning security flags, labels, privileges, and authorization sets to files

- Recovering the system to a trusted state in the event of a system failure

*Managing the audit system:*

Access to the auditing commands is limited to users with the **AUDITSYS** authorization. For more information, refer to the **audit**, **auditselect**, and **auditpr** commands.

The following example shows:

1. How to create a filesystem to be used for the audit trail files
2. How to start the audit system
3. How to cause some records to be generated
4. How to parse the audit trail to retrieve various types of records.

Run the following commands as a user with **FSADMIN** authorization:

```
/usr/sbin/crfs -v jfs -g rootvg -m /audit -a size=32M -A yes
mount /audit
```

Use the **/sbin/autlmod -e** command to add the following entry to the users section of the **/etc/security/audit/config** file:

```
username = ALL
```

Replace *username* with the name of a real user who can log onto the system.

As an ISSO user, create a file called **/tmp/top\_secret** and change the SL of the file to **TS ALL**.

```
touch /tmp/top_secret
/usr/sbin/settxattr -f sl= "TS ALL" /tmp/top_secret
```

Run the following command as a user with **AUDITSYS** authorization:

```
/usr/sbin/audit start
```

The audit system has now been set up and started so that it will record the actions of the user specified by *username* when this user logs on to the system.

Log on to the system with the user specified by *username* in the **/etc/security/audit/config** file and run the following commands:

```
ls -l /tmp/top_secret
exit
```

As a user with **AUDITSYS** authorization, run the following commands:

```
audit shutdown
$ /usr/sbin/auditselect -e "mac_fail==WILDCARD" /audit/trail | \
/usr/sbin/auditpr -v -APSV > /tmp/audit_trail-mac_failure
```

Examine the audit trail that was redirected to the **/tmp/audit\_trail-mac\_failure** file and search for **mac\_fail**. The **auditselect** has been modified to accept the following options:

- **subj\_sl**
- **obj\_sl**
- **mac\_fail**
- **mac\_pass**
- **mic\_fail**
- **mic\_pass**
- **priv\_fail**



- **priv\_pass**
- **auth\_pass**
- **fsf\_fail**
- **fsf\_pass**

These options all use the word **WILDCARD** as the matched value.

#### *Managing object and processes labels:*

Every filesystem object and system process have associated labels.

All filesystem objects other than regular files have a range of sensitivity labels and an integrity label. Processes have a range of both sensitivity and integrity labels. In addition to the ranges, processes have an effective SL and effective TL. This label indicates the current SL or TL at which the process is running. You can view the labels with the **lstxattr** command. You can set the labels of the filesystem objects and processes with the **settxattr** command.

#### *Managing network security:*

AIX Trusted Network requires that several tables be defined by the ISSO. These tables are stored in the `/etc/security` directory. The **tninit** command is used to generate the binary version and then load it into the kernel.

Host and network interface rules determine how the system deals with incoming and outgoing network packets. Host rules apply to specific hosts. Network interface rules apply to interfaces through which hosts connect to the network. If there are any conflicts between a host rule and an interface rule, the host rule takes precedence.

Use the **netrule** command to add, edit, and query rules. In general, the rules pertain to protocols used, ranges of addresses (both hosts and ports) to which to apply the rules, and which SLs to assign to the packets. See the **netrule** command for more information.

Use the **tninit** command to initialize the AIX Trusted Network subsystem, to save the rules in binary format, and to display the rules in text format.

#### *Security configurable features:*

The configurable feature settings are displayed during the boot sequence.

The configurable settings are stored in the ODM. These settings can be displayed with the **getsecconf** command and can be modified by an ISSO user with the **setsecconf** command.

#### *Managing labels:*

An ISSO user can add, modify, or delete label encodings by modifying the `/etc/security/enc/LabelEncodings` file. The `/etc/security/enc/LabelEncodings` file defines how human-readable names are mapped to the binary representation of system sensitivity labels.

**Note:** Modifying the sensitivity label encodings file on a running system can result in invalid labels unless extreme care is taken. Since objects can be labeled with single words or constrained combinations of words, carelessly changing, adding, or deleting word combination constraints can result in invalid labels.

The `/etc/security/enc/LabelEncodings` file is translated into binary form by the **L\_init** library routine and stored in tables. These tables are used to convert SLs, printer banners, and clearances to and from their internal binary encodings.

Trusted AIX uses the MITRE Compartmented Mode Workstation Labeling software as the basis for labeling implementation. The document Compartmented Mode Workstation Labeling: Encodings Format, DDS-2600-6216-93 (MTR 10649 revision 1), September 1993 explains the standard label encodings format.

The standard label encoding format treats the integrity labels and sensitivity labels the same as given in the **Sensitivity Labels** section of the `/etc/security/enc/LabelEncodings` file.

Trusted AIX optionally supports an **Integrity Labels** section which allows the integrity labels to be different from the sensitivity labels.

#### *Managing partitioned directories:*

To a normal user process, a partitioned directory appears and functions the same as a regular directory. However, with a partitioned directory, different processes with different SLs see different contents of the same directory.

For example, if a process running at the **SECRET** security label creates a file named **foo** in a partitioned directory, then a second process running at the TOP SECRET security label cannot see or access the file **foo** in that directory. Also, the second process can create its own **foo** file without interfering with the first **foo** file.

This is accomplished using hidden subdirectories. For each unique SL with which a process accesses the partitioned directory, there is a partitioned subdirectory. When a process accesses the partitioned directory, the system automatically redirects the process to the hidden subdirectory. In the example above, the two **foo** files are actually in different subdirectories, even though they appear to the user to be in the same directory.

See “Partitioned directories” on page 411 for more information on partitioned directories.

Partitioned directories are supported in JFS2 with EAv2.

#### *Creating a partitioned directory:*

When a partitioned directory is created, the default SL range is System Low SL to System High SL. When a partitioned directory is accessed, the kernel automatically creates a label-specific child directory (if one does not already exist) and redirects the user process to this child directory.

Use the **pdmkdir** command to create a partitioned directory. The **pdmkdir** command requires **aix.mls.pdir.create** authorization to override DAC, MAC, and MIC restrictions. Use the **pdrmdir** command to remove an empty partitioned directory.

### **Partitioned subdirectories and sub-subdirectories**

The label-specific child directories of a partitioned directory are partitioned subdirectories. When a process creates a child directory under a partitioned subdirectory (with the **mkdir** command), the child directory is a partitioned sub-subdirectory.

When a partitioned subdirectory is created, it inherits the security attributes of its parent partitioned directory, except for the minimum SL and maximum SL. The minimum and maximum SL are set to the effective SL of the virtual mode process that first accesses the partitioned subdirectory.

Trusted AIX recognizes four different types of directories:

- regular directory (`dir`)
- partitioned directory (`pdir`)

- partitioned subdirectory (psdir)
- partitioned sub-subdirectory (pssdir)

#### *Virtual mode and real mode:*

There are two different partitioned directory access modes: virtual mode and real mode.

In virtual mode, a process accessing a partitioned directory can only see the contents of its label-specific partitioned subdirectory. A partitioned directory is never visible to a process running in virtual mode. A partitioned directory is visible to a process running in real mode. Processes running in real mode can see all real contents of partitioned directories and partitioned subdirectories. For real-mode processes, the system does not perform any redirection.

By default, processes run in virtual mode. Real mode is intended only for file system administration purposes. Use the **pdmode** command to run commands in a mode other than that of the current process shell or to switch to a shell in a different mode.

Although a real-mode user process can see and manipulate partitioned directories and subdirectories, this type of access and manipulation should be performed with caution. For example, if a regular directory is created or moved into a partitioned directory by a real-mode process, the directory will never be visible to processes running in virtual mode.

Although a partitioned directory looks like a regular directory to a virtual-mode process, there are still some restrictions on the partitioned directory.

#### *Hierarchy:*

There is a hierarchy of partitioned directories and subdirectories.

The following rules govern the hierarchy of partitioned directories and subdirectories:

- A directory must be one of four types:
  - a regular directory
  - a partitioned directory
  - a partitioned subdirectory
  - a partitioned sub-subdirectory
- A directory cannot be of more than one type at any time
- The parent of a partitioned subdirectory must be a partitioned directory
- Every child directory of a partitioned subdirectory must be a partitioned sub-subdirectory
- The parent of a partitioned sub-subdirectory must be a partitioned subdirectory

Any violation of these rules results in an invalid partitioned directory tree and an inconsistent file system whose behavior is undefined.

#### *Mounting filesystems:*

A partitioned directory or subdirectory can be a mount point, but a partitioned sub-subdirectory cannot be a mount point. Similarly, the root of a filesystem that is being mounted can be a partitioned directory or subdirectory, but it cannot be a partitioned sub-subdirectory.

#### *Creating and deleting directories:*

When a virtual-mode process running is in a partitioned sub-subdirectory, the **mkdir** command creates a regular directory. If the same process is in a partitioned subdirectory and executes a **mkdir** command, a partitioned sub-subdirectory is automatically created. Any empty directory can be deleted, subject to MAC, MIC, and DAC restrictions.

*Moving directories:*

MAC, MIC, and DAC restrictions apply when directories are moved.

A regular directory can be moved anywhere. If its new parent directory is a partitioned subdirectory, the regular directory that was moved become a partitioned sub-subdirectory. Otherwise, it will still be a regular directory. If its new parent is a partitioned directory and its name clashes with the name of a potential partitioned subdirectory, any later virtual-mode process redirection to that potential partitioned subdirectory will fail.

A partitioned directory can be moved to another regular directory and it will still be a partitioned directory after being moved. Nested partitioned directories are not supported in Trusted AIX because they provide no additional advantage.

A partitioned subdirectory can only be moved into a partitioned directory and is still a partitioned subdirectory after being moved. Moving a partitioned subdirectory into a regular directory, a partitioned subdirectory, or a partitioned sub-subdirectory is prohibited.

A partitioned sub-subdirectory can be moved anywhere. If its new parent is a regular directory, a partitioned directory, or a partitioned sub-subdirectory, it becomes a regular directory. Otherwise, it is still a partitioned sub-subdirectory.

*Table 37. Directory movement summary*

| Move directory of type       | To regular directory                      | To partitioned directory                                | To partitioned subdirectory                                    | To partitioned sub-subdirectory           |
|------------------------------|-------------------------------------------|---------------------------------------------------------|----------------------------------------------------------------|-------------------------------------------|
| Regular                      | Allowed. Remains a regular directory      | Allowed <sup>1</sup> . Remains a regular directory.     | Allowed <sup>1</sup> . Becomes a partitioned sub-subdirectory. | Allowed. Remains a regular directory.     |
| Partitioned                  | Allowed. Remains a partitioned directory. | Allowed <sup>1</sup> . Remains a partitioned directory. | Not allowed.                                                   | Allowed. Remains a partitioned directory. |
| Partitioned subdirectory     | Not allowed.                              | Allowed. Remains a partitioned subdirectory             | Not allowed.                                                   | Not allowed.                              |
| Partitioned sub-subdirectory | Allowed. Becomes a regular directory.     | Allowed. Becomes a regular directory.                   | Allowed. Remains a sub-subdirectory.                           | Allowed. Becomes a regular directory.     |

<sup>1</sup> If the name clashes with the name of a potential (currently nonexistent) partitioned subdirectory, any later virtual-mode process redirection to the partitioned subdirectory will fail.

*Changing directory type:*

The **pdset** command can be used to change a regular directory to a partitioned directory type. There is no command to change a partitioned directory to a regular directory.

*Replacing inode numbers:*

When a partitioned subdirectory is accessed and its inode number or the inode number of its parent partitioned directory (..) is needed, the inode number of its parent partitioned directory or the inode number of the parent of its parent partitioned directory is returned, respectively. When a partitioned

sub-subdirectory is accessed and the inode number of the parent of the partitioned sub-subdirectory(..) is needed, the inode number of its grandparent partitioned directory is returned.

*Partitioned directory commands:*

These commands apply to partitioned directories.

**pdmkdir**

Create partitioned directories

**pdrmdir**

Remove partitioned directories and subdirectories

**pdlink** Link files across partitioned subdirectories

**pdset** Set directories to partitioned directories

**pdmode**

Return current directory access mode

Run command with specified directory access mode

A regular directory that has been converted to a partitioned directory can be converted back to a regular directory.

*System security review:*

It is the responsibility of the ISSO to review the security status of the system. A system security review needs to be carried out immediately after installation and at any other time that the system integrity may have been compromised, and system security reviews should also be conducted periodically.

The system integrity database directory, which is stored in the **/etc/security/tsd/tsd.dat** file, contains security-related information of filesystem objects such as critical commands and system devices. This database must be updated when a new device is added or the security information of the files is modified. See the **trustchk** command for more information.

The **trustchk** command compares the current security settings of a file, directory, or device with the corresponding entry in the system integrity database and repairs any security attribute inconsistencies. The **trustchk** command can only be run by an ISSO-authorized user.

*TTY management:*

The minimum SL, maximum SL, and TL for tty devices are defined in the ttys database in the **/etc/login.cfg** file. Refer to **chsec** command for more information.

The effective SL of the user logging in over the TTY port should be within the range defined for this port in this file. If a TL other than NOTL is specified for the TTY port, then the effective TL of the user must be the same as the specified TL.

*Managing user clearances:*

Each user, including the ISSO, SA, and SO users, must have labels to log in to the system. The user clearance can be specified in the **/etc/security/user** file as part of the user's stanza. The **minsl**, **maxsl**, **defsl**, **mintl**, **maxtl**, and **deftl** attributes specify the minimum SL, maximum SL, default SL, minimum TL, maximum TL, and default TL, respectively, for the user. If these attributes are specified in the user's stanza, the values specified in the default stanza of the file are assigned to the user.

Only an ISSO user can modify the security clearance database. The user's clearance can be listed with the **lsuser** and **lssec** commands and can be modified using the **chuser** and **chsec** commands.

The default SL value must be dominated by the maximum SL value and must dominate the minimum SL. Similarly, the default TL value must be dominated by the maximum TL value and must dominate the minimum TL.

**Note:** For a user to successfully log in to the system, the above relation must hold true.

### ***Managing the system for System Administrators:***

SA users are primarily responsible for the aspects of the system administration that are not related to security.

The responsibilities of SA users include the following:

- Adding, removing, and maintaining user accounts
- Sharing with the ISSO user the task of ensuring the internal integrity of system software and filesystems
- Creating and maintaining file systems. This includes planning disk layout, partitioning disks and changing disk partition sizes, allocating swap space and space for system and user directories, monitoring filesystem usage, detecting and handling bad disk blocks, and managing filesystem space by moving, deleting, archiving, or compressing files and file systems.
- Identifying and reporting system problems by analyzing error data and testing system components such as filesystems, system memory, and devices.

### *Managing user accounts:*

The SA user is responsible for adding new users to the system. The ISSO user is responsible for enabling new users to log on and execute commands on the system.

See *Managing the system for Information System Security Officers* for information on adding authorizations to user accounts.

Once the SA user has added a user has been added to the system, an ISSO user must be notified so that the initial password can be set up to enable the new user to access the system.

When it is determined that a user should no longer have access to the system, the user should be immediately removed. Removing a user can only be done by an SA user. The user ID of a user removed from the system should not be reused unless it is given back to the original user, and then only when reinstating this user on the system.

See the **mkuser**, **rmuser**, **chuser**, and **pwadm** commands for information on establishing and modifying user accounts

### *Managing printers:*

Once a printer has been properly installed, it is added to the system by the combined actions of SA and SO users. The SO user adds the printer to the system and the SA user establishes the printer's SL range. An ISSO user has the authority to perform both of these tasks.

**Note:** For the CC LSPP evaluated configuration, the printer must be treated as a single-level device and the low and high SLs must be set to the same label.

The printer's SL range must not be established until the printer has been added to the system. Use the **smit** command to manage printers.

**Note:** Labeled printing of PostScript® and ASCII files is only supported on PostScript printers.

MAC access to a printer is determined by the SL of the process that is printing the file. This SL appears on the banner, header/footer, and trailer pages. The process using the **lp** command must have MAC, MIC, and DAC access to the file that is being printed. Otherwise, the **lp** command does not generate a print request.

When a printer is removed from the system, the printer profile should be immediately deleted from the system. This can only be done by a user with the SO authorization.

#### *Managing filesystems:*

A filesystem consists of directories, data files, executable files, and special files. A filesystem can reside on various mass storage devices such as hard disk drives and floppy diskettes.

Although only an SA user can create and maintain filesystems, both SA and SO users can mount and unmount filesystems.

#### *Checking filesystems with the fsck command:*

The internal integrity of a filesystem should be checked periodically with the **fsck** command. The **fsck** command must be run on unmounted filesystems. The **fsck** command can only be executed by an SA user.

By default, the **fsck** command runs interactively, prompting the user for the action to perform when an orphaned file or directory is found. A user has an option to delete the file or attempt to recover the file. If a user specifies that the file should be recovered, the **fsck** command attempts to store the file in the **/lost+found** directory.

After the **fsck** command has completed and recovered files are stored in the **/lost+found** directory, an ISSO user should review the files to determine their security level. It is recommended that the **/lost+found** directory be assigned the **SYSTEM\_HIGH** SL to prevent normal users from accessing recovered files.

See the **fsck** command for more information.

#### ***Managing the system for System Officers:***

S0 users are primarily responsible for the security-related aspects of the system administration.

#### *Managing filesystems:*

System Officers are responsible for filesystem management

#### *Supported filesystems:*

Trusted AIX supports all disk-based filesystems.

All filesystems except JFS2 are supported on Trusted AIX as single-level filesystems. These files systems can be mounted on a Trusted AIX system, will automatically receive labels and other security attributes, and will be subject to the security mechanisms enforced by Trusted AIX. All file objects in a single-level filesystem have the same security attributes. These security attributes are inherited from the mount point.

JFS2 is implemented on Trusted AIX as multilevel filesystems. Each file object in a multilevel filesystem has its own security attributes (security labels). For example, a JFS2 directory has independent minimum and maximum SLs.

In single-level filesystems, the minimum and maximum SLs of the mount point are equal and all directories and files below the mount point must also equal those SLs.

### *Mounting and unmounting filesystems:*

An SO user (with the **aix.fs.manage.mount** authorization) is allowed to mount or unmount a filesystem. The **mount** command uses the device special file name and the mount directory as options.

When multilevel JFS2 filesystems are mounted, the mount directory is assigned the label of the root of the file system. On a multilevel filesystem, each file has its own sensitivity and integrity labels. If a file is modified, its label is updated accordingly.

### *Managing printers:*

An SO user can use the **lpadmin** command to add and remove printers, modify printers, and exercise certain other types of control over the printer subsystem. An SA user can use the **lpadmin** command to add or modify the Sensitivity Labels (SLs) for a printer and can use the **enable** and **disable** commands to enable and disable printers.

### *Printer subsystem:*

The printer subsystem performs many tasks related to printer operation.

Printer subsystem tasks include the following:

- Administering printers and their attributes
- Receiving, storing, and scheduling user print jobs
- Scheduling print jobs for multiple printers
- Starting programs that interface with printers
- Keeping track of the status of printers and print jobs
- Reporting problems when they arise
- Restricting user print jobs to those that fall within the SL range of the printer
- Restricting access to user print jobs once submitted
- Restricting access to printer support files and directories
- Proper labeling of printer output

### *Printer security features:*

The printer subsystem is modified in Trusted AIX to incorporate several security features.

The printer subsystem is a protected subsystem owned by the system ID **lp**. This prevents normal users from accessing printer support files and directories, other than the user's own submitted print jobs, and printer device special files.

The printer subsystem verifies that the user's submitted print job falls within the printer's SL range. This verification is performed when a user submits a print job with the **lp** command and before the submitted job is printed by the **lpsched** daemon. The administrator should be aware of the printer subsystem security checks in case a user's print job is denied.

Banner pages are printed for all print jobs. The banner page includes the print job's human-readable SL. A banner page appears at the front and rear of all print jobs. Any user can print without banners, but this is an auditable action. You should always verify that the header and footer labels on each page are correct and are dominated by the labels on the banner page.

**Note:** The line printer administrator must establish the label range for each printer. For the CC LSPPEvaluated configuration, each printer must have a single label to prevent inadvertent disclosure of labeled information. To assign a single label to a printer, run the following command:



**lpadmin -d printer\_name -Jlabel -Llabel** This ensures that only information with the specified *label* can be printed on the printer.

*Printer command summary:*

Some printer subsystem commands can be run by any user. However, some printer subsystem commands can only be run by an SO, SA, or ISSO user.

The following table lists the printer subsystem commands can be run by any user:

**lp** Sends a file to a printer  
**lpstat** Gives a status report of the printer subsystem

Printer subsystem administration commands require SO authorization, except that a user with SA or ISSO authorization can run the **lpadmin** command to specify a label range of the printer and run the **lpstat** command to display printer and job request SLs. The following table lists the printer subsystem administration commands:

**accept** Allows jobs on a printer  
**cancel** Cancels a print request of a file  
**disable** Deactivates a printer  
**enable** Activates a printer  
**lpadmin** Sets up or changes printer configuration  
**lpfilter** Sets up or changes a printer filter  
**lpforms** Sets up or changes a printer form  
**lpmove** Moves print requests  
**lpsched** Prints a request  
**lpshut** stops the print service  
**lpusers** Sets up or changes print priority  
**reject** Prevents jobs on a printer

*Command line printer management:*

You can use the **accept**, **enable**, **disable**, **lpstat**, and **lp** commands to manage a printer from the command line.

You can use the **accept** command to allow jobs to be sent to a printer. Run the following command to allow the printer *laser* to accept print jobs:

```
/usr/sbin/accept laser
```

The printer specified by *laser* can now receive print job requests. However, the print jobs will not be printed unless the printer is enabled. Run the enable command to enable a printer:

```
/usr/bin/enable laser
```

The **enable** and **disable** commands are administration commands and can only be run by a user with ISSO or SA authorization.

To confirm that the printer was set up properly, run the following **lpstat** command:

```
lpstat -p laser -l
```

This command displays the long status report of the printer *laser*. If you run the **lpstat** command without the **-l** option, a shorter status report displays. If the user is an SA or ISSO authorized and the **-l** option is used, the SL range of the printer is also reported.

To determine the status of a print request, run the following **lpstat** command:

```
lpstat -o
```

This command lists all **lp** print requests. If the user is SA or ISSO authorized, the effective SL and clearance of each request is reported.

To print the filename, run the following **lp** command:

```
lp -d laser filename
```

Otherwise, you must specify the print job destination when you run the **lp** command.

If a default destination printer has been set by the administrator, the **-d destination\_ptr** option is not necessary. For example, to print the file filename on the printer laser, the enter the following **lp** command:

```
lp filename
```

#### *Managing system shutdown:*

An SO user can shut down the system either by either rebooting the system or halting the system completely.

The following commands can be run by an SO user to reboot or halt the system or to change the init state of the system:

#### **reboot**

Automatically reboots the system

#### **halt**

Halts all system operations

#### **shutdown**

Halts all system operations

#### **init**

Changes the system's init state

#### *File backup and restore:*

Backups help prevent data loss in the event of a hardware failure or the accidental deletion of a file. Backups should be made on a regular basis, with incremental backups made between complete backups.

The **backup** and **restore** commands include options to specify file backup names, locations, types, and other options. You can use the **mksysb** command to creates a Trusted AIX installable image of the root volume group, either in a file or on a bootable tape. You can run these commands using the **smit** command. Filesystem backups should be properly labeled and stored in a secure location.

## Trusted AIX programming

System security depends on the trusted computing base (TCB) software, hardware, and firmware. This includes the entire operating system kernel, all device drivers and System V STREAMS modules, kernel extensions, and all trusted programs. All files used by these programs in making security decisions are also considered a part of the TCB.

The creation of trusted software requires a thorough understanding of the basic system security principles and features. Almost all security flaws in UNIX-based systems are due to poorly written trusted software. However, with Trusted AIX kernel security checks, you can write applications that use enhanced security features. An application written for Trusted AIX can be sensitive to files and processes at different security levels and can behave differently depending on the level of process or file that the application is using. Such an application is known as a multilevel-aware (MLS) application.

A trusted system programmer must be thoroughly versed in Trusted AIX security features and must understand all new Trusted AIX system calls and security-relevant commands and libraries. This information is intended for programmers who create or modify trusted software. It contains guidelines, principles, and cautions for the modification and creation of trusted software. While this offers introductory explanations to some security principles and methods, it is recommended that trusted system programmers read other material on secure systems.

### Principles of trusted software

There are several important principles involved in creating and modifying trusted software, including trust and privileges, trusted software design, least privilege, programming conventions, and protection of the TCB.

#### *Trust and privilege:*

A process can bypass basic security restrictions (MAC, MIC, DAC, and other restricted operations) only if the process is adequately privileged. Any process that is running with a privilege or privileges is called a privileged process and the program that the process is running is called a privileged (trusted) program.

The term privilege refers to an individual attribute that allows a process to perform a security-related operation. Trusted AIX identifies and groups certain security operations and associates a distinct privilege with each operation. This effectively removes the superuser (or root) privilege from the base system. Privileges are associated with processes and executable files.

Programs must be trusted under the following circumstances:

- The program is configured or is intended to run as a privileged process. This applies to any program that is intended to be run by a privileged process.
- The program is relied upon by another trusted program in making security decisions. For example, a program that alters a sensitive database must be trusted if other programs rely on the data in the database to make a security decision.

It is important to ensure that untrusted programs can never run as privileged processes. There are several ways to prevent untrusted programs from running as privileged processes:

- Do not normally allow privileged processes to execute untrusted programs. For example, caution users running privileged shell-like programs not to run untrusted programs in a privileged shell-like program.
- Never allow innate, inherited, or authorized privileges for untrusted executable files.

All portions of the operating system kernel, including device drivers, STREAMS modules, and kernel extensions, must be trusted. Data objects such as files and physical devices are also considered trusted if they contain information relied on by a trusted program to make security decisions.

#### *Trusted software design:*

The process of creating trusted software is similar to that for any critical software component. The creation of trusted software should follow a carefully understood and documented specification, design, implementation, testing, and configuration control cycle.

The most important aspects of trusted software design are the identification of the subjects and objects and the definition of precise security actions at the proper level of abstraction. Most security policies are restrictions on subjects, objects, and actions. When subjects request permission to read, alter, or create objects, security policies monitor those requests and approve or deny these requests.

### **Subjects**

A subject is normally represented by a user ID and group IDs. Normally the process's effective user and/or group ID is used for this purpose, although it may be appropriate in some cases to use the real user and/or group ID.

### **Objects**

An object is any collection of data to which access should be controlled. In most cases, objects are files. Although it is common for trusted programs to control access to logically distinct objects within the same file, it is generally better practice to map objects one-to-one onto files.

In some cases, a subject can also be considered an object. For example, a process is normally considered a subject. However, when one process attempts to affect a second process, the second process is normally considered an object with respect to this operation.

### **Requests**

Requests are sets of actions that a trusted module performs on behalf of a subject. Each request must be clearly identified in terms of the request's inputs, possible outputs, and results, including all side effects. The precise identification of all requests is an important prelude to the definition of security policies.

### **Security policies**

Security policies include simple statements indicating when requests involving specified objects will be performed on behalf of specified subjects. Subjects, objects, and requests should be carefully defined and security policies should be concise and straightforward. It is important to specify the identity of the requesting subject and the objects involved for the purposes of auditing.

#### ***Least privilege:***

The principle of least privilege states that software modules should be given the minimal capabilities needed to accomplish their intended task.

Least privilege includes the principle that trusted programs should voluntarily limit their own sensitive capabilities to be usable in as few areas of the program as possible. Least privilege helps to reduce the damage from software errors or from unexpected side effects. All trusted software should be designed according to the principle of least privilege.

#### ***Assignment and removal of privilege:***

One trusted software technique is for a program to perform all operations for which privilege is required early in its execution and then to relinquish privilege for the remainder of the duration of its operation. This is called privilege bracketing.

Remember the following considerations related to the use of privileges:

- Each user's process is assigned a set of maximum privileges at process execution. This set of privileges can always be reduced but can never be increased by the unprivileged user.
- It is the responsibility of the executing process to raise and lower the privileges of the maximum set into and out of the effective set when performing privileged operations.
- Process privileges are modified when processes run executable files which have non-empty innate privilege sets. See the **exec** command for more information.
- Processes are also given a limiting privilege set when the processes are run. With appropriate privileges, a process can raise privileges in the maximum set up to those in the limiting set.

#### *Short-lived MAC label changes:*

When a process must change its MAC label from its normal operating label, the duration of the label change should be as brief as possible. This can be accomplished with the use of library routines.

See "Trusted AIX system calls" on page 477 for more information on these library routines.

#### *Short-lived opens of sensitive files:*

A sensitive file is a file, such as the shadow password file that contains information that could compromise system security. When sensitive files are opened for reading or writing, they should be kept open only as long as necessary.

The **close-on-exec** attribute of the file descriptor should be set using the **fcntl** system call. This prevents unauthorized processes from inheriting open file descriptors via the **exec** system call.

#### *Centralization of sensitive operations:*

A sensitive operation is an operation that requires privileges. If a sensitive operation is performed by an unprivileged process, it can compromise the security of the system.

Sensitive operations should be restricted to distinct modules (subroutines or separate programs). By breaking down a large program into separate programs, some of the programs will need fewer or no privileges. This lessens the possibility of accidental compromise of the system's security.

#### *Use of effective root directories:*

A program can be confined to a particular directory tree by setting the program's effective root directory to the base directory of the tree (with the **chroot** system call) and setting the program's working directory inside this same tree. In effect, this is a least-privilege mechanism because it limits the files that even a privileged process can access to those within the tree. This can be particularly effective when the parent (trusted) process so limits trusted or untrusted child processes.

While changing root directories provides protection to files outside of the new root tree, it does pose a potential security problem. Changing the root directory can create a means of comprising the security of the new root tree if this is not done cautiously. This occurs when the runtime linker and shared objects in the new root tree can be forged. This procedure should be used carefully and sparingly.

#### *Use of protected subsystems:*

Protected subsystems provide integrity protection for special subsystems. A subsystem is a collection of programs and/or data files, owned by the same user ID and/or group ID, that are used to implement a specific function in the system.

A subsystem can include **setuid** or **setgid** programs. A protected subsystem is a subsystem with a user ID that is a system user ID.

A system user ID is a user ID with a value less than or equal to 127. Users cannot log in with system user IDs. Using protected subsystems can significantly reduce the number of privileged processes.

*Minimal access modes:*

Trusted programs (actually all programs) should only open objects in read/write access modes that are absolutely necessary. Basically, this means never opening an object for write-and-read when opening for read is sufficient. For particularly sensitive situations, the process should open for write-only in the specific locations where write is required.

These techniques are particularly important when a program creates other processes, since the passing of privileges and other general capabilities (for example, open connections to sensitive files) is a critical aspect of trusted software design. Privileges can override all restrictions. Careful design and consideration should be applied when creating new commands that will have privileges.

***Other trusted programming conventions:***

Trusted AIX uses many other trusted programming conventions.

*Redundancy:*

Redundancy is a useful technique for security systems. Security is seldom absolute, but is instead almost always a matter of placing a sufficient number of roadblocks in the path of anyone attempting to improperly access a system.

The advantage of redundant security checks is that if one check fails or is compromised, other checks may provide protection. The disadvantage of redundant checks is that the overall security checks are separated or distributed through the system. Therefore, while redundant checks can be extremely useful, they must be carefully designed, documented, and maintained.

*Non-duplication of kernel checks:*

It is rarely advisable for a process to perform a check that the kernel can perform. For example, a process should never read the MAC label of a file and perform the mandatory access check itself. Whenever possible, checking the kernel should perform a check.

There are two major reasons that the kernel should perform checks.

- Kernel operations are atomic with respect to other processes, whereas process checks can be effectively concurrent with other processes.
- More importantly, the precise algorithms used can change with newer kernel versions. It is difficult to track such changes for algorithms that are a part of end-user software.

*Direct privilege checking:*

Programs should not attempt to determine whether they are invoked as privileged processes (for example, by examining their effective or maximum privilege vector). Instead, programs should assume they are invoked as privileged where appropriate.

If the program is not a privileged process, the privileged system calls will fail and the program can take the appropriate action. It is not usually an effective security measure for a program to itself refuse to perform certain operations unless it is privileged. If the program is privileged, then the check is meaningless. If the program is not privileged, then the program can do no more harm than any other unprivileged process.

However, this check can be used effectively as an aid to accidental misuse. A meaningful error message can be given stating that the program was intended to be privileged but is not.

### *Propagation of sensitive capabilities:*

A sensitive capability is a capability of a trusted program that could compromise the security of the system if provided to an untrusted program.

Caution should be used when a privileged program propagates its privileges or general capabilities to other programs via the **fork** and **exec** family of system calls. The **exec** system calls are the most important since these pass privileges from one program to another. The **fork** system call creates a new process, but the new process privileges are identical to those of the parent. The primary danger is that the executable program file may not be trustable or may have been altered by an untrusted program. The following cautions should be considered:

- Trusted programs should be careful to not pass open connections to objects (primarily files) to a child process unless the child and its descendants can be trusted to properly access the file in the mode in which the file is opened. It may be best for the process to pass a new connection to the object whose modes are more restrictive than those that would otherwise exist.
- A trusted process that runs with an effective root directory other than absolute root should be confident that its child processes will not be confused. For example, when the child program opens a trusted file, such as the shadow password file, it can use an absolute pathname under the assumption that its effective root is absolute.
- There may be cases in which the trusted program needs to impose a more restrictive umask on its children.
- Many process attributes are inherited by child processes. If a trusted program knows that a child process is untrusted and has a MAC label that does not dominate that of the trusted process and these attributes were inherited by the trusted program from an untrusted ancestor, then these attributes can be a source of potential covert channels.
- Be aware of the rules of privilege propagation for the **fork** and **exec** system calls. Privileges of the parent process become the privileges of the child process when a **fork** system call occurs. Privileges are modified during an **exec** system call.

In extremely sensitive situations, a trusted program can examine the access controls on a trusted file to help ensure that the file is properly protected from modification by untrusted programs. For example, a file can be required to be owned by root with at most DAC write permission allowed for the file's owner.

### *Effective root environments:*

Trusted programs frequently rely on correct absolute pathnames. For example, the **login** program relies on the **/etc/security/passwd** file to be the correct shadow password file.

This includes not only data files, but also the executable files for trusted programs. While an untrusted program cannot use the **chroot** system call to directly change the program's effective root directory, there may be situations in which the TCB allows untrusted programs to run under an effective root. There are potential security problems if these untrusted programs can execute a trusted program that relies on an absolute pathname.

### *Authentication with real and effective IDs:*

Trusted programs may need to use several user and group IDs that are associated with a process. It is important to understand the distinctions between these IDs and their appropriate use.

### **Real user and group IDs**

Real user and group IDs normally represent the login identity of the login session in which a process was created. In some cases, real IDs (particularly the real user ID) can be used for security decisions. One such instance is authorization checking. Real user IDs are used by commands as a form of identity verification. This can be particularly useful in thwarting malicious or careless use of the **setuid-on-exec** or

**setgid-on-exec** control bits. However, checking real IDs departs from standard UNIX practice and should only be done when necessary. The overall principle in UNIX systems is that effective IDs are used for access and other related security checks. Departing from this accepted practice should not be done without careful consideration and documentation.

### **Effective user and group IDs**

Effective user and group IDs should be used in all access control decisions (DAC and MAC). System users have user ID values between 0 and 127. Normal users have ID values of 128 and above.

#### *Absolute pathnames for trusted commands:*

Some security penetration schemes attempt to create a fake trusted program and place it in the search path of a shell-like program that is being used by an administrative or even regular user. For example, a fake copy of the **passwd** command can be used to capture an existing or new user password.

Proper administrative practice is for the current working directory to be removed from the search path to guard against this. However, there may be other search paths that are not necessarily strongly protected, and regular users must be allowed to put the current working directory in their search path. An effective counter measure is for a trusted program to always be invoked by an absolute pathname (for example **/usr/bin/passwd**). The trusted program itself checks its first invocation argument and invocation name. If the appropriate absolute pathname is not used, the trusted program refuses to run. The trusted program should also ensure that it does not have an effective root directory that is different from absolute root.

**Note:** This is effective only to the extent that users are trained to issue the absolute pathname. If a user inadvertently uses the relative pathname instead and a fake program is invoked, the security penetration scheme is not averted.

#### *Directory tree structuring:*

Directory trees should be carefully structured to enhance the protection of critical files. The basic guideline is that directory search access should be as limiting as possible (for example, placing all publicly accessible files into directories that close to the root of the file system).

It is also a good idea to place very sensitive directories as close to absolute root as possible, since this minimizes the number of intermediate directories that need to be protected.

#### *Read-only filesystems:*

Perhaps the ultimate in directory tree structuring is where trusted files that are seldom changed are placed on their own filesystem and mounted as read-only. This virtually ensures that their contents cannot be modified during normal system operation. This technique is often used for large collections of executable files for trusted programs.

If modification of a file is required, the filesystem can be remounted as writable in a more protected context (for example in single-user mode or on a separate, more protected machine). It is recommended that programs be used to scan the filesystem for correct configuration (for example, proper DAC, MIC and MAC labels) after such updates.

In addition, the DAC, MIC, and MAC information cannot be altered on a read-only filesystem. Once the filesystem is properly configured, this should protect against security penetration schemes that attempt to alter the DAC information and/or MIC and MAC labels.

#### *Password handling:*



It is generally not a good practice for programs other than the standard system utilities to query the user for the login password. Passwords are extremely sensitive information and their handling should be tightly restricted to the few existing well-trusted system utilities.

It may be appropriate for certain trusted subsystems to implement their own specific passwords. However, it can be dangerous to rely on such private password schemes since these are not as secure as the system-enforced mechanisms.

#### *Protection of the Trusted Computing Base (TCB):*

Files that hold elements of the TCB must be protected from modification, and in some cases disclosure (reading), by untrusted programs.

Protection from modification is critical, and protection from disclosure can be critical. Files that must be protected include the following:

- All files that contain data used by a trusted program in making a security decision (for example the shadow password file)
- All executable files for trusted program
- Pseudofiles that allow access to portions of the TCB (for example **/dev/kmem**).

**Note:** System initialization files (the rc files) must especially be protected as a part of the TCB

#### *Protection from modification:*

Protection from unauthorized modification is primarily accomplished by setting the DAC information to an appropriate value. Normally, these files would be owned by a system user ID with write access allowed only to the owner of the file.

MIC is designed to protect against modification by protecting the integrity of objects. By placing a high MIC label on a file, processes with a lower MIC label are prevented from modifying, deleting, or renaming the file. This is the ideal method to prevent unwanted modification of files.

In some cases, MAC can be used to protect against unauthorized modification. However, MAC is designed to protect only against disclosure (reading) and is not well suited for protecting against modification. Basic MAC policy does not prohibit subjects from modifying higher-label objects. Although not allowed for direct file writes, certain trusted subsystems may allow this. Also, many trusted files, such as executable program files, need to be kept at a low MAC label so that they can be generally accessed. Therefore, setting a high MAC label on a file is not always feasible.

File security flags also protect against file modification. some file security flags prevent modification of objects by even privileged subjects. If the **FSF\_TLIB** file security flag is set for a file, the file can only be changed when the system is in configuration mode, assuming the **trustedlib\_enabled** kernel security flag is turned on. To set **FSF\_TLIB** for a file, a process must have the **PV\_TCB** privilege in its EPS. Another relevant file security flag is the **FSF\_APPEND** flag, which prevents the modification of previously written data. A file with the **FSF\_APPEND** flag set can only have data added to it. This can be useful for an application that logs records to a file.

These flags are usually set for files by integrators rather than under program control. Programmers should be aware of these flags and their functions.

#### *Protection from disclosure:*

DAC and MAC can be used to protect TCB files from read access. The MAC labels on these files must accurately reflect the sensitivity of the information in these files. For example, if a certain algorithm is classified, then the MAC label on the executable file of a program that uses the algorithm must be appropriately set.

It is acceptable practice to set the MAC label artificially high (that is, higher than the actual classification of the data in the file) to protect the data from disclosure. However, such inflated classifications should be used sparingly.

In almost all cases, the entire directory chain from absolute root must be protected in order for a file itself to be adequately protected. Otherwise, a malicious program may be able to unlink a portion of the directory chain and create a new subtree with a fake copy of the file.

For example, suppose a trusted file is stored at `/A/B/foo`. While `foo` is protected from modification, the directory `B` is not. A malicious untrusted program could then remove the link in `B` to `foo` and create a new file `foo` with a false copy of the old file `foo`. Trusted programs that open `/A/B/foo` will then open the false file and will have been unwittingly fooled into using its false data.

Trusted programs rely on correct pathnames to access TCB files. For this reason, the symbolic link files used in pathnames for TCB files should be protected as strongly as the files themselves.

In some cases, MIC can be used to protect against unauthorized disclosure. However, MIC is primarily intended for protection only against modification (writing) and is not well suited for protection against disclosure.

#### *Sensitivity label operations:*

There are trusted program guidelines for situations involving subjects or objects with different sensitivity labels.

You should be familiar with the form of a sensitivity label and the dominance relationship between labels. To be higher than means to dominate, and to be lower is to be dominated by, while to upgrade means to raise the classification of data to a higher label, and to downgrade means to lower the classification of data to a lower label.

#### *Basic MAC constraint:*

The basic mandatory access control constraint is that untrusted subjects cannot cause data labeled at sensitivity label A to be labeled at B unless B dominates A.

The basic MAC constraint covers all classes of data. It includes restrictions on relabeling data (that is, changing the label on a data container) and on the movement of labeled data between data containers.

At various levels of the system (system call, system service utilities, etc.), this basic constraint is cast into more specific sets of rules, but always with the same basic philosophy, that data can, at most, be upgraded. For example, a first level of expansion is that processes can open for reading any of a large class of objects when the label of the process dominates the label of the object, and open for writing if the label of the object dominates that of the process.

For a regular file, write operations are further restricted to files at the same label as the process. For directories and devices, write operations are allowed if the subject SL dominates the object minimum SL and the object maximum SL dominates the subject SL. For FIFO special files (named pipes), read operations are also restricted to FIFO special files at the same label as the process for covert channel reasons.

While data can migrate to a higher sensitivity label, this capability is not required for a given object and situation. For example, the operating system itself does not let an unprivileged process open a higher label file for writing, although this is permitted under the basic MAC constraint. Whether to allow this upgrading to untrusted subjects is a matter of design and philosophy. In some cases this is useful and in some cases it is not. For example, the difficulty associated with direct writes to higher-label files is that the process cannot read these files, and so the write to a higher-label file is less than useful. However, a simple trusted utility that raised the label of a file at the request of an untrusted subject can be an acceptable and useful utility.

At the system-call level, the restriction is only on unprivileged processes. This means that privileged processes are not bound by this constraint. However, virtually all services that the trusted system performs will be designed for untrusted users, and therefore at the user-service level the constraint predominates.

The basic MAC constraint applies to all of the means that untrusted programs have at their disposal to transfer data. However, the basic MAC constraint is often broken into two components. The first component deals only with those operating system features intended for data transfer (or labeling). These features include reading and writing files and interprocess data communication, for example. The second component deals with means of communication not intended as such; these are called covert channels. It is nearly impossible to completely enforce the basic MAC constraint with respect to covert channels. For this reason, low data rate (for example, 0.1 bits per second) covert channels are allowed to exist, although only when there is a reasonable trade-off against other factors.

The basic MAC restriction is straightforward and simple, and there are relatively few detailed guidelines for dealing with multilevel data.

#### *Multilevel operations:*

The **sec\_setplab** system call allows a privileged process to arbitrarily change its process label.

Since nearly all MAC and MIC constraints on unprivileged processes are also enforced for privileged processes on preexisting system calls (that is, those that are defined in the base operating system), privileged processes that need to perform multilevel operations must rely heavily on the **sec\_setplab** system call. However, trusted programs should only use `sec_setplab()` only in the following manner:

- All uses of the **sec\_setplab** system call to perform multilevel operations (for example, opening higher label files for reading) should be done only through library routines that reflect the semantics of the actual, high-level operation performed and that hide the detailed use of the **sec\_setplab** system call.
- The only exceptions are very simple process label changes that are not a part of a larger multilevel operation. These simple operations can use the **sec\_setplab** system call directly.

There are two reasons for these guidelines for the **sec\_setplab** system call. First, a sensitive and potentially dangerous feature such as the **sec\_setplab** system call should only be used in a well-designed, modular manner. Second, as standards for trusted systems evolve, low-level system calls may support various mechanisms for multilevel operations.

Encapsulating high-level operations in library routines provides excellent upward compatibility and adaptability to evolving versions of the operating system and helps ensure portability between trusted versions of the UNIX system.

The trusted system provides a basic set of such routines. These routines should be used whenever possible. This set of routines should be expanded with successive operating system versions. A trusted system programmer can also create such library routines where needed.

Another exception to the MAC and MIC constraints is the use of one or more of the available MAC or MIC privileges to bypass the MAC or MIC restraints. Care should be exercised when allowing the use of any of these privileges.

### *System V Interprocess Communication (IPC):*

Interprocess Communication (IPC) mechanisms (message queues, semaphores, and shared memory) are subject to DAC, MIC, and MAC restrictions. Normally, there are no commands for creating and using System V IPC objects.

The AIX IPC-related system calls have been modified to be multilevel-aware for Trusted AIX. These modified system calls are:

- **msgget**
- **msgsnd**
- **msgrcv**
- **msgctl**
- **semget**
- **semop**
- **semctl**
- **shmget**
- **shmctl**
- **shmat**
- **shmdt**

In addition, the following system calls designed specifically for manipulating the MAC attributes of IPC objects have been added to Trusted AIX:

#### **sec\_getmsgsec**

Get security attributes of message queues

#### **sec\_getsemsec**

Get security attributes of semaphores

#### **sec\_getshmsec**

Get security attributes of shared memory segments

#### **sec\_setmsglab**

Set security attributes of message queues

#### **sec\_setsem lab**

Set security attributes of semaphores

#### **sec\_setshmlab**

Set security attributes of shared memory segments

See Access to IPC objects for the privilege requirements for processes to manipulate IPC objects. The **settxattr** command can be used to manipulate an IPC attribute.

### *Implementation of high and system high MIC and MAC labels:*

It is often necessary for a trusted process to determine a MAC label that dominates all other labels on the system. There are two different MAC labels that can be used, the implementation high MAC label or the system high MAC label.

The implementation high MAC label is the highest MAC label supported by Trusted AIX. It is likely that this label has a hierarchical classification and contains categories that are not in use for the site. This label is easily generated, but the label must be used with care. No process should create objects at this label.

The system high MAC label is the highest MAC label that is in use for the site. This is defined by the administrator in the **LabelEncodings** file.

The use of the system high MAC label is less efficient but is highly recommended since the administrator can effectively constrain the actions of even privileged processes by properly setting the appropriate parameter in the **LabelEncodings** file.

MIC has analogous implementation high and system high labels.

*User and system login ranges:*

Trusted programs that perform services for users may need to limit MIC and MAC labels involved in those operations to values at which the user is allowed to log in and/or to the system-wide allowed login labels.

The clearances that are assigned to users on the system are in the **user** database file **/etc/security/user** and are accessed using the **getuserattr** and **getuserattr** library routines.

Trusted AIX allows users to operate on the system at any label that is listed in the system accreditation range and that is dominated by the user's maximum clearance and that dominates the user's minimum clearance. All programs that allow users to operate at different labels should always ensure that the new label is valid for the user.

For example, suppose a utility named **upgrade** was defined to raise the MAC label on a file at the request of any user. The basic MAC restriction demands that **upgrade** only accept files whose MAC label is dominated by that of the user. Further, it is deemed prudent (although not strictly necessary from the basic MAC restriction) that the new label be one at which the user is allowed to log in, which includes both per-user and system-wide label range restrictions. The **upgrade** utility would use both the **sl\_cmp** and **accredrange** interfaces for this purpose.

*Directory tree structure:*

The system calls function so that directory trees created by unprivileged processes follow a nondecreasing label structure, where the label of a file equals that of its parent directory or is within the range of the partitioned directory, and the label of a directory dominates that of its parent directory (note that domination includes equivalence). This is a natural structure for untrusted programs.

However, privileged processes are not bound by this restriction and can create directory trees where the parent directory MAC label relationships are arbitrary. Such configurations are useful because MAC search access is restricted closer to the root of the tree. For example, aggregation protection, where the MAC label of a collection of data objects is higher than any single label of the objects, can be implemented by setting the MAC label of a directory higher than any of its elements. Untrusted processes must then dominate the label of the directory to gain access to the aggregation of data.

Great care should be used in creating directory trees that have decreasing labels. It is not possible for an unprivileged process to open a file for writing when the file does not dominate or equal its parent's label.

*Partitioned directory manipulations:*

There are several system calls that have different behavior as a result of the implementation of partitioned directories.

The following system calls behave differently as a result of the implementation of partitioned directories:

- getdirents
- link
- mkdir
- mount
- rename
- rmdir

- stat
- lstat
- fstat

#### *Process mode:*

The **pdmode** command can execute a command with a specified mode. A process can use the **setppdmode** system call to set its own mode to real mode or virtual mode. The **setppdmode** system call requires the **PV\_PROC\_PDMODE** privilege to succeed. There is no mechanism for a process to change the mode of another process.

#### *Directory type:*

The **pdset** command can be used to change a regular directory into a partitioned directory, but there is no command to change a partitioned directory (or partitioned subdirectory or sub-subdirectory) to a regular directory.

The **pdmkdir** system call can also be used to create partitioned directories. The **pdmkdir** system call requires the **PV\_FS\_PDMODE** privilege.

#### *MIC and MAC label considerations:*

All programs should use only the **sl\_cmp** and **tl\_cmp** functions to determine the relationship between MIC and MAC labels.

This is extremely important since the internal label format can change with later system versions and these library routines track the evolving formats. Similarly, there are many other library routines that manipulate MIC and MAC labels that should be used wherever possible.

The **setea**, **lsetea**, and **fsetea** system calls change the MIC or MAC label of a file. The **fsetea** system call accepts a file descriptor.

#### *Device drivers:*

There are some principles and guidelines that should be followed when creating device drivers for Trusted AIX systems. You should be familiar with the mechanisms for creating device drivers for the base system and with precautions regarding the use of these mechanisms.

#### *Device management subsystem:*

A device in an AIX system is an abstraction and is used to cover all data objects accessed by referencing device special files. In some cases, these data objects represent actual physical devices and in some cases they are quite different (including cases such as **/dev/null** where there is no data storage object at all). The latter instances are often referred to as pseudo-devices.

Trusted AIX systems provide two types of devices: single-label and multilevel devices. A multilevel device is trusted to process data at more than one sensitivity level at a time. A single-label device is usually untrusted. The labels on the data are normally associated with the information that a multilevel device handles in a way that ensures that the data is always properly labeled. A single-label device normally relies on exterior labeling.

A hard disk is an example of a multilevel device. All of the data that is placed on a hard disk has associated sensitivity labels. A printer is physically located in an environment which requires a security clearance to enter is an example of a single-label device. Only data at that clearance can be sent to the printer.

### *Device driver development cautions:*

Device drivers are part of the operating system kernel and as such are unrestricted in their actions. The creation or modification of device drivers is as sensitive as modification of the kernel itself. Unfortunately, end users often need to create or modify device drivers. This should only be done with extreme caution.

It is impossible to list all of the specific cautions to be used when writing device drivers, since there are so many ways that drivers (sometimes quite innocently) can subvert the security of the system. Therefore, the creation of secure device drivers is left more to the judgment and experience of the designers.

Device drivers should perform nothing more than simple device management. Device drivers created essentially for the purpose of adding new system calls to the system, including many pseudo-device drivers such as those for **/dev/kmem**, should be considered new system calls and designed accordingly. The guidelines in this section refer principally to those drivers that are legitimate device managers.

You should study standard device drivers before you attempt to create new ones. The principal security actions of device drivers are those involved with the execution of the **open** and **ioctl** system calls.

### *Opening devices:*

As with most system objects, most of the security checks associated with accessing a device are performed when the device is opened with the **open** system call.

The kernel first performs a set of basic operations and then passes the processing of the open request to the device driver. The kernel makes the following security checks before passing control to the device driver:

- If the process does not have MAC access to the device special file, the open fails
- If the process does not have MIC access to the device special file, the open fails
- If the process does not have DAC access to the device special file, the open fails

With many devices, reading from the device (with the **read** system call) alters the state of the device in a manner that can be detected by another process whose MAC label does not dominate the reading process. This constitutes a potential covert channel. Devices that are first-in-first-out (FIFO) in nature are subject to this problem. In these cases, it is common practice to restrict read access to processes that are at the same MAC label as the device. This is done by a check within the device driver.

There are few specific rules or guidelines for the design of irregular devices. You must understand and apply the basic principles of mandatory and discretionary access control. Fortunately, most device drivers can be configured as regular devices and the eccentricities of irregular device drivers do not need to be dealt with often.

### *Device driver open examples:*

The following are examples of irregular device handling taken from standard system device drivers. These are intended to illustrate the possible diversity of such device drivers.

#### **/dev/null**

**/dev/null** is a pseudo-device that has no data container. Data written to **/dev/null** is discarded and end-of-file (EOF) is always returned in response to read requests. Therefore, no MAC device restriction on open is required. For compatibility, DAC access on the **/dev/null** device file is required although this is not strictly necessary.

## **/dev/tty**

When a process issues an open on **/dev/tty**, the device driver actually attempts to open the terminal that is the controlling terminal of the requesting process. Therefore, MIC, MAC, and DAC access must be checked for the process's controlling terminal process instead of for **/dev/tty**. For compatibility, DAC access to **/dev/tty** is required, although this is not strictly necessary.

### *ioctl restrictions:*

Although all device-driver interface functions must be trusted, the **ioctl** interface usually requires special attention.

As a general rule, only processes with write access can alter a characteristic of a file that can be detected by other processes who do not have write access. Having write access means either that the process has the file open for writing or that the MAC label of the process is equal to the label of the device. This restriction stems from the basic MAC restriction that no process can perform an action that can be detected by processes at lower MAC labels.

If the purpose of the action is a user data read/write operation, then the restriction must be enforced as stated. Otherwise, cases where the restriction is not enforced are considered covert channels, and should be bandwidth limited and/or auditable.

Some device control actions may need to be limited to privileged processes even when the device is not configured as a trusted device.

### *Other restrictions:*

There are relatively few other cases where the device driver may need to enforce special security checks.

One example is when a read on a device alters the state of the device in a manner that can be detected by a process whose MAC label is not dominated by that of the reading process. This presents a potential covert channel that may need to be restricted or audited by the device driver itself.

### *Device driver programming summary:*

The following guidelines should be considered when implementing device drivers.

**Note:** New system calls have been added to support extended security for each read/write on Streams and FIFO devices. Two new library API's, `eread()` and `ewrite()` support this extended security attribute. If it is an MLS Kernel, a security flag `DEV_SEC_ERDWR` is set on the device. Similarly for FIFO `GNF_SEC_ERDWR` is set on the device. These flags enable additional security checks on each read/write.

## **General design techniques**

All security checks within the device driver should be written in a modular fashion and should be easily identifiable.

### **Checks within device drivers**

It is always better to keep MIC, MAC, and DAC checks out of a device driver. Device drivers without such checks can be easily ported to or from untrusted systems or other types of trusted systems.

In a regular device driver implementation, the kernel performs MIC, MAC, and DAC checks and the driver performs any additional required privilege checks. In an irregular device driver implementation, all checks (MIC, MAC, DAC, and privilege checks) are performed in the device driver. The choice of whether to



implement a regular or irregular device driver is a matter of design judgment.

## DAC

DAC is enforced for each device special file based on the filesystem entry point used to access the device.

### Checking for correct installation

Any device driver that performs MAC checks should securely handle (within reasonable bounds) the possibility that the device was defined incorrectly.

### Privileged access

It may ne appropriate for a device driver to limit certain device operations to privileged processes. However, there are a few specific recommendations for these situations.

You can use the **refmon** kernel function to determine if you have the necessary privileges.

#### *Least privilege:*

Trusted AIX introduces the least privilege concept. Least privilege separates the once-powerful root user into a privilege mechanism with finer granularity. This division of privileges ensures that if there is a programming error or other defect in the trusted software, very little damage to system security is possible.

#### *Privilege operations:*

There are four privilege vectors associated with each process: effective, maximum, inheritable, and limiting.

The maximum privilege vector defines the upper limit for the privileges that can be active for each process. The effective privilege vector defines the privileges that are examined to make a privilege decision. Note that the effective privilege set is always a subset of the maximum privilege set, which in turn is always a subset of the limiting privilege set. The limiting privilege set defines the privileges that a process may have in its maximum, inheritable, and effective privilege sets. The inheritable privilege set represents the set of privileges that are inherited by the child processes across forks and execs.

When a new text image is executed, the privilege escalation is performed based on the following algorithm. The special privileges mentioned are **PV\_ROOT**, **PV\_SU\_**, **PV\_SU\_EMUL**, **PV\_SU\_ROOT**, **PV\_AZ\_ROOT** and **PV\_SU\_UID**.

The following algorithm demonstrates two important concepts about the least privilege subsystem. The first concept is that the special privileges (**PV\_ROOT**, **PV\_SU\_**, **PV\_SU\_EMUL**, **PV\_SU\_ROOT**, **PV\_AZ\_ROOT**, and **PV\_SU\_UID**) are the only privileges that are allowed to unconditionally propagate across the execution of a new process image. The second concept is that the process's effective privilege vector is cleared of all privileges unless the file has **FSF\_EPS** set. This ensures backward compatibility with applications that may need to run under the trusted system without being bracketed for the least privilege system.

```
new_max_privs = old_inheritable_privs
new_max_privs = new_max_privs | file_innate_privs
IF (user was assigned some of authorizations in file PAS)
new_max_privs = new_max_privs | file_authorized_privs
new_max_privs = new_max_privs & old_limiting_privs
IF (old_max_privs contain one or more special privileges)
new_max_privs += same set of special privileges
IF (FSF_EPS is set for the executable)
new_eff_privs = new_max_privs
```

```
ELSE
new_eff_privs = old_inheritable_privs
IF (old_eff_privs contain one or more special privileges)
new_eff_privs += same set of special privileges
new_limiting_privs = old_limiting_privs
```

#### *Assignment and removal of privileges:*

The following standard system library routines illustrate how privileges are manipulated on the system. These routines are only useful to privileged programs on the system.

#### **priv\_raise**

Changes the process's effective privilege vector by adding (or raising) the specified list of privileges. The list of privileges must be in the process's maximum privilege vector or an error indication is returned.

#### **priv\_remove**

Changes the process's effective and maximum privilege vector by removing the specified list of privileges. If the process cannot remove the effective or maximum privileges, an error indication is returned.

#### **priv\_lower**

Changes the process's effective privilege vector by removing (or lowering) the specified list of privileges. If the process cannot lower the effective privileges, an error indication is returned.

Each of these routines accepts a comma-separated list of privileges that are terminated by a **-1** (negative one, an invalid privilege number). The technique for raising and lowering privileges around the smallest section of code that may require these privileges is known as privilege bracketing. All trusted applications should use privilege bracketing to reduce the likelihood of security violations by poorly designed or implemented software.

#### **setppriv**

Changes the process's effective, maximum, inheritable, and limiting privilege vector by setting the privilege sets. If the privilege sets passed are invalid or are not permitted, an error indication is returned.

#### *Authorizations:*

Authorizations provide various sets of privileges to users with certain authorizations.

Typically, a command or utility checks for any relevant authorizations at the beginning of execution and then sets its own privileges accordingly. Therefore, users with a specific authorization receive a different set of privileges for each command performed, according to how the command is programmed.

To remove cumbersome privilege setting from the code itself, AIX provides authorization sets and privilege sets external to a binary. With the Privileged Authorization Set (PAS) and Authorized Privilege Set (APS), the system, rather than the command itself, performs privilege setting based on authorization.

#### **checkauths**

Compares the passed in list of authorizations to the authorizations associated with the current process.

For more information about authorization checking, see "RBAC Authorizations" on page 78.

#### *Auditing:*

Trusted AIX includes a set of commands for managing the audit trail generation and information. It is unlikely that a trusted system programmer will need to modify or add to these programs.

**audit** Controls the audit daemon

**auditbin**

Controls audit trail files

**auditselect**

Merges and selects audit records from audit trail files

**auditpr**

Displays the selected audit events in human-readable form

The primary area where audit is of concern to the trusted system programmer is in the audit events that are generated by trusted programs. Most trusted programs need to issue messages to the system audit trail.

*Situations to audit:*

There are few precise guidelines for determining which situations should be detected and audited by a trusted program. It is primarily a matter of judgment and audit strategy. The base system divides situations into successes, failures, object accesses, and possible covert channels.

*Successes:*

It is important to audit successful operations to establish a basic usage history.

For example, it is important that a device allocation program records when a particular user allocates and deallocates a device. This allows a program to trace the flow of information through the system and determine responsibility if the device is later determined to have been misused. On the other hand, some auditing philosophies have little concern about successful operations, because such operations were determined to be legal and proper by the trusted software.

*Failures:*

Auditing failed operations can be useful to detect users who attempt to gain access to disallowed services or data. The frequent occurrence of such failures can indicate malicious (if not particularly clever) personnel.

The base system divides failures into five categories:

- Privilege failures (an attempt by an unprivileged process to perform an action that is restricted to privileged processes)
- MAC failures (failure of an action because the action would violate MAC restrictions)
- MIC failures (failure of an action because the action would violate MIC restrictions)
- DAC failures (failure of an action because the action would violate DAC restrictions)
- Other failures (for example, an attempt to log in with an incorrect password)

*Object accesses:*

It is necessary to audit object access to monitor users who access a given object (for example, the shadow password file).

*Potential covert channels:*

Auditing of potential covert channels is important since covert channels can be used for passing information between processes at different MAC labels. The use of potential covert channels does not mean that these channels were used for this purpose, only that such use is possible.

Each entry written by the audit system includes the reason for the audit entry (success, MAC failure, MIC failure, DAC failure, privilege failure, other failure, object access, or potential covert channel). This includes both audit records written by the system itself and audit records written by user programs.

It can be useful to consider whether the user was trusted (that is, an administrator), but there is no absolute method of determining whether trusted or untrusted user require stronger auditing. For example, although administrators are assumed trusted and in this regard may require less auditing, their actions can be far-reaching and it can be useful to record the actions of an unauthorized administrator. Regular users can do less damage and in this sense require less auditing, but they are also less trustworthy and therefore may need more auditing. System administrators often apply increased auditing to their actions to demonstrate their innocence in the case of a security breach.

The following events should be auditable:

- Successful operations, especially those that involve the transfer of information or the changing of access control parameters
- Operations that fail for security reasons
- Operations by administrators, whether successful or not
- The potential use of covert channels
- Operations that access a specific object
- Actions that affect the subsequent content of the actual audit trail

#### *Audit information levels:*

High-level audit information is more useful than low-level audit information. Trusted programs maintain a high-level view of operations and can produce excellent audit messages.

Recording only that an administrator opened a security file for writing is much less useful than recording the actual higher-level operation that was performed on the file (for example, recording that an administrator created a new entry in the file, including the key information for the new entry). It is highly recommended that audit information be at as high of a level as possible.

It is better to include information about a single event rather than include information about several events. The principal reason for splitting an audit occurrence among more than one event is so that the separate occurrences can be selectively enabled.

#### *Audit classes and events:*

Each trusted program must determine the audit class, audit event type, and reason that it uses when it issues audit messages using the **auditlog** system call.

Each audit event belongs to an audit class. By assigning events into classes, you can more effectively deal with a large numbers of events. Audit class definitions are defined in the **/etc/security/audit/config** file.

The audit class is used to enable and disable the recording of events. If it is important for two events to be separately enabled, these events should not be in the same audit class. However, it is generally a good practice to group events into classes. Normally, each trusted program or set of related trusted programs will reserve one audit class name (or in rare case, a few audit class names) for its own use.

The system actions that are auditable are defined as audit events in the **/etc/security/audit/events** file.

#### *Covert channels:*

All trusted software is assumed to not participate in covert channel schemes. In addition, the software must be designed so that it cannot be utilized by untrusted software to exploit covert channels. This section defines covert channels and gives guidelines for their detection and limitation.

*Definition of covert channels:*

No process at a label A shall be able to perform an action that is detectable by another process at label B except when label B dominates label A.

This definition can be broken down into two situations: direct data operations and incidental operations. Direct data operations are intended for users as a direct means of storing or communicating user data, such as reading and writing files. These operations must absolutely adhere to the basic MAC constraint. All other operations are incidental operations. The use of an incidental operation to pass data contrary to the basic MAC restriction is called a covert channel.

The exploitation of a covert channel requires two untrusted processes, which will be referred to as the sender (at label X) and receiver (at label Y). It is assumed that the MAC label of the receiver does not dominate that of the sender (if it did, data flow from the sender to the receiver would be a legal upgrade). To exploit this channel, both the sender and receiver utilize certain conventions regarding the use of agreed-upon resources in order to transmit data contrary to MAC.

The only criteria for covert exploitation is that the receiver's label of the receiver does not dominate the sender's label and that both the sender and receiver are untrusted. Both the sender and receiver are commonly used on behalf of the same user. It is assumed that the TCB itself upholds the basic MAC restriction and is free of any code that violates this restriction by the malicious use of covert channels. (In fact, privileged processes have many more effective ways to violate MAC without having to resort to covert channels.) It is the ability of untrusted processes to exploit covert channels by using trusted programs that is of concern.

In general, covert channels should be precluded from the system. However, there are some cases where other system needs (for example, performance, reliability, or compatibility) are unacceptably constrained without the presence of covert channels.

*Bandwidth guidelines:*

The base system uses the following guidelines for the limitation of covert channels based on bandwidth:

**More than 100 bits/second**

These channels are not allowed to exist

**0.1 to 100 bits/second**

Channels in this range can exist when absolutely necessary, but their use is detected and audited whenever possible

**Fewer than 0.1 bits/second**

Channels in this range can exist where necessary but there is no special need to detect their use

It is highly recommended that all additional TCB programs follow these same guidelines. Furthermore, consider that even relatively slow channels of 10 bits per second can transmit 4,500 bytes per hour, which is a significant amount of data to be illegally downgraded. Therefore, every effort should be made to limit covert channels to as low a bandwidth as possible.

The bandwidth of most covert channels is usually lowered by activities of processes other than those processes that may be exploiting the channel. However, it is recommended this effect not be relied on to limit the bandwidth of covert channels, since there are periods of low activity on all systems.

*Detection of covert channels:*

Detection of covert channels is largely a matter of careful analysis and design. There are few specific guidelines for the detection of covert channels.

The term module refers to the unit of TCB code that detects or limits covert channel use, whether in the kernel or in a process. Detecting covert channels is primarily a matter of determining whether an untrusted process (the sender) at a level A can use a module to perform an action that is detectable by another process (the receiver) at level B, when level B does not dominate level A.

For example, a common covert channel is data that is written to a file by a trusted process on behalf of an untrusted user when the MAC label of the file does not dominate the MAC label of the user.

Relatively few methodologies for detecting covert channels have been proposed. The most prominent is the Shared Resource Matrix (SRM). Refer to the following for a description of this technique:

- • Kemmerer, R.A. "Shared Resource Matrix Methodology: An Approach to Identifying Storage and Timing Channels," ACM Transactions on Computing Systems 1(3) 1983, 256-277.
- • Tsai, CR. "A Formal Method for the Identification of Covert Storage Channels in Source Code," Proceedings of the 1987 IEEE Symposium on Security and Privacy, 74-87.

#### *Covert channel detection through auditing:*

The ability to audit the potential use of a covert channel can be an effective counter to this threat. However, in order for the auditing to be useful, the audit event must be relatively rare. The audit is of little use if the ratio of actual exploitations to the incidental use of the event that causes the audit is low.

#### *Limiting covert channels:*

The best way to limit covert channels is to simply remove them.

Otherwise they should be limited according to the guidelines discussed in Bandwidth Guidelines. In addition, whenever possible and effective, potential use of the channels should be audited.

In general, it is difficult for kernel or device driver code to confine covert channels, since the kernel and device driver code are designed for efficiency and their channels are higher bandwidth. Trusted processes can more easily limit covert channels.

**Note:** There is no reason to limit covert channel use by processes at the same label or when the receiver dominates the sender. Therefore, most TCB modules can increase system performance by imposing no limitations in these cases.

#### *Per-label quotas:*

Many covert channels involve the use of a resource pool that is shared among processes at different MAC labels. These can be effectively limited by creating separate fixed-size resource pools for each MAC label, so that a process can only modulate resource use from the pool for its MAC label.

Over time, unused resources can be moved from one pool to another to accommodate dynamic demand. This resource migration is itself a covert channel, but one of much lower bandwidth that is easily limited.

#### *Time delays:*

One technique for limiting covert channels is for the TCB to ensure that a certain amount of time passes when a service where channels exist is performed. This can be as simple as having the module sleep for a specified time, which can be calculated based on the amount of information that is being passed.

However, unless properly done, time delays can often be thwarted by programs that are exploiting the covert channel. For example, the exploiting processes can create many sets of sender/receiver processes. While the TCB can easily limit each set to a certain bandwidth using delay techniques, the aggregate of all sets is the bandwidth of this single channel.

It is better for a certain TCB service to ensure that time delays are applied in some manner to all processes that might be using the service.

Time delays can be useful for confinement, but they are prone to relatively simple countermeasures by malicious programs and must be carefully designed.

#### *Data limitations:*

The covert channel bandwidth can be lowered not only by increasing the time, but also by decreasing the amount of information that is returned. Programs that return data as a series of operations can often simply return fewer or smaller packets of information within the same time frame.

#### *Approximate time:*

Many of the techniques for exploiting covert channels require the exploiting processes to have an accurate way to measure relative or absolute time. These channels can sometimes be limited by not allowing the process to accurately determine time.

While it is relatively easy to ensure that TCB services that return time information make the time approximate, processes sometimes have other ways of measuring the passage of time, such as counting their own instruction times. Such techniques for limiting channels should be used with care.

#### *Noisemakers:*

The bandwidth of most covert channels is usually lowered, sometimes drastically, by the activities of processes other than those that are exploiting the channel. It is possible, though not recommended, to create trusted programs whose purpose is to ensure that a certain level of activity is always present. These are sometimes known as noisemakers.

While the use of noisemakers may be conceptually appealing, it is usually difficult for noisemakers to determine when they should be making noise and when they should not. Therefore, this is not a recommended technique for covert channel limitation.

#### *U-T-U chains:*

There may be situations where an untrusted process, **U1**, invokes a privileged, trusted process, **T**, which then invokes another untrusted process, **U2** which is at a different label than **U1**. **U1** and **U2** represent untrusted processes at different MAC labels with special covert channel potential by virtue of one being a descendant of the other. (Actually, T and U can be sequences of trusted and/or untrusted processes.) We refer to this situation as the U-T-U chain.

Trusted processes must ensure that information does not pass between two untrusted processes against the basic MAC principle, which includes both the exclusion of disallowed direct data operations and also covert channels. You should consider the following:

- File descriptors cannot be left open when **U2** could not have opened the file in the read/write mode in which it is open
- The environment variables must be cleared if the label of **U2** does not dominate U1
- The working directory passed from **U1** through to **U2** can constitute a covert channel (probably small) if the label of **U2** does not dominate **U1**. Similarly, many of the process parameters that are automatically inherited by the child process could constitute a covert channel.

It is possible for U-T-U chains to be managed properly (that is, the covert channels can be sufficiently constrained). However, this is difficult to ensure, and U-T-U chains should generally be avoided. Note, however, that the concern is that U2 is not trusted--it might safely be trusted but unprivileged.

*Examples of covert channels:*

The following are examples of covert channels that might exist in modules created by a systems programmer.

*Printing service covert channel example:*

This is an example of a printing service covert channel.

A trusted line printer service correctly tags each submitted job with the MAC label of the requesting process and maintains that label with the queued jobs for use in eventual printing. Jobs with relatively long names are allowed.

A status program allows the user to see all of the jobs that are queued for the user, including the user-assigned job name, regardless of the label of the job. This can be used as a covert channel since the sender process can then create jobs whose name contains data to be covertly passed to receivers that operate on behalf of the same user.

**Note:** The only criteria for covert exploitation is that the receiver's label does not dominate the sender's label and that both the sender and receiver are untrusted. Both sender and receiver will commonly be on behalf of the same user.

This channel is closed by allowing the user to only view jobs that are dominated by the user's current MAC label. This forces the MAC label of the receiver to dominate that of the sender and the channel can only be used for a legal upgrade. As a matter of courtesy, the status program could give the user an "other jobs exist" message if non-dominated jobs existed. This represents a much smaller channel with a good operational reason for existence.

**Note:** Auditing the detection of higher-level jobs can be useful, since this detection will probably be rare in normal operation.

This is a common example of a covert channel where multilevel named data objects (queued printing jobs in this case) are accessible by processes at different MAC labels. The channel is effectively removed by applying the MAC label of the object to the name also. Attributes other than name, such as size, can also carry covert information.

*Resource pools example:*

When a trusted program performs a service for an untrusted client, the trusted program allocates a specific type of resource (for example a buffer) from a pool of resources that is shared among processes at different MAC labels.

One way to use this as a covert channel is for the sender and receiver to arrange to have all but one resource allocated, possibly by other programs running at different or diverse MAC labels or under different or diverse user IDs. The sender then causes the single remaining resource to be allocated or not allocated, and the receiver detects this by also trying to allocate the resource.

This is a classic example of a shared resource channel. This can be confined by the allocation of per-label resource pools as described above. It can also be detected by auditing.

*Databases example:*



A trusted database system allows user programs to place data into a multilevel database. Direct access is properly controlled via the basic MAC restrictions.

However, the time required to place an entry into a database is highly dependent on the current total size of the database. Therefore, the sender can place or remove entries to affect the size of the database, and the receiver can simply measure the time it takes to place an entry to detect this size. This channel is likely to be low bandwidth unless the database access is quite efficient.

A guaranteed minimum access time can be imposed in an effort to limit the channel. The time delay can be pseudorandom so that the average wasted time is lessened. However, this is still a time delay scheme and should be carefully implemented.

The simple auditing of all accesses is not likely to be effective since it will be difficult to detect the exploitation of the channel among the many non-malicious uses of the database.

#### *Programming examples:*

This section provides several trusted programming examples

#### *Trusted program privilege check example:*

This is a modular routine for a trusted program to check whether or not the calling process has a specific privilege.

```
#include <sys/priv.h>
#include <sys/secattr.h>

int
priv_check (int priv)
{
 /* the process's security attributes */
 secattr_t secattr;

 /* get the calling process's security attributes */
 if (sec_getpsec(-1, &secattr;) != 0)
 {
 return (-1);
 }
 /* error retrieving the process's cred structure */
}

/*
 * return whether or not specified priv is in the
 * calling process's maximum privilege set
 */
return privbit_test(secattr.sc_maxpriv, priv);
}
```

#### *Change effective Sensitivity Label example:*

This program changes the effective sensitivity label of the current process to system high.

The following privileges are required in the program's innate privilege set:

- **PV\_LAB\_LEF**
- **PV\_LAB\_SLUG**
- **PV\_LAB\_SL\_SELF**

```
#include <stdio.h>
#include <m1s/m1s.h>
#include <unistd.h>
#include <sys/secattr.h>
#include <userpriv.h>
```

```

#include <sys/mac.h>
#include <sys/secconf.h>

#define SUCCESS 0
#define ERROR 1

int
main()
{
 sl_t sl_syshi; /* System high SL */
 secattr_t attr;
 char *c1Buffer = NULL;

 /*
 * Get the system high and low SLs.
 */
 if ((sec_getsyslab(NULL, &sl_syshi, NULL, NULL)) != 0) {
 fprintf(stderr, "Call to sec_getsyslab failed.\n");
 exit(ERROR);
 }

 /*
 * Initialize this process with initlabeldb() to access the
 * system default Label database.
 */
 priv_raise(PV_LAB_LEF, -1);
 if (initlabeldb(NULL) != 0) {
 fprintf(stderr, "Could not read the Label Encodings Database.\n");
 exit(ERROR);
 }
 priv_remove(PV_LAB_LEF, -1);

 /*
 * Get the process clearance range and effective SL.
 */
 priv_raise(PV_LAB_SLUG, PV_LAB_SL_SELF, -1);
 if (sec_getpsec(-1, &attr) != 0) {
 fprintf(stderr, "Problem getting Trusted AIX security attributes of program.\n");
 exit(ERROR);
 }

 /* malloc for the maximum SL label length that can be formed for process */
 if((c1Buffer = (char *) malloc(maxlen_c1())) == NULL) {
 perror("malloc");
 exit(ERROR);
 }
 /* Convert the binary effective SL to human readable */
 if (c1btohr(c1Buffer, &attr.sc_sl, HR_LONG) != 0) {
 fprintf(stderr, "Unable to convert SL to human readable form.\n");
 exit(ERROR);
 }
 printf("Program's initial effective SL = %s.\n",c1Buffer);

 /*
 * Set the process effective SL to system high.
 * The process may not have its maximum SL at system high,
 * so set it also to system high.
 */
 attr.sc_sl = sl_syshi;
 attr.sc_sl_c1_max = sl_syshi;

 if (sec_setplab(-1, &attr.sc_sl, NULL, &attr.sc_sl_c1_max,
 NULL, NULL, NULL) != 0) {
 fprintf(stderr, "Problem setting the effective SL of program.\n");
 exit(ERROR);
 }
}

```

```

priv_lower(PV LAB_SLUG, PV LAB_SL_SELF, -1);

if (sec_getpsec(-1, &attr) != 0) {
 fprintf(stderr, "Problem getting Trusted AIX security attributes of program.\n");
 exit(ERROR);
}

/* Convert the binary effective SL to human readable */
if (c1btohr(c1Buffer, &attr.sc_sl, HR_LONG) != 0) {
 fprintf(stderr, "Unable to convert to SL to human readable form.\n");
 exit(ERROR);
}
printf("Program's modified effective SL = %s.\n", c1Buffer);
return(SUCCESS);
}

```

### *Setting sensitivity label classifications and comparing sensitivity labels examples:*

This is an example of setting the classifications of sensitivity labels and using the library routines for comparisons between the sensitivity labels.

The **PV LAB\_LEF** privilege is required in the program's proxy privilege set and in the calling process's maximum privilege set.

```

#include <stdio.h>
#include <m1s/m1s.h>
#include <userpriv.h>
#include <errno.h>

#define SUCCESS 0
#define ERROR 1
int
main (int argc, char **argv)
{
 /* Sensitivity labels */
 sl_t sl1, sl2;

 /* strings to hold labels' names */
 char *slBuffer1 = NULL;
 char *slBuffer2 = NULL;

 if (argc != 3) {
 fprintf(stderr, "Usage: compare slabel1 slabel2\n");
 exit(ERROR);
 }
 /*
 * Initialize this process with initlabeldb() to access the
 * system default Label database.
 */
 priv_raise(PV LAB_LEF , -1);
 if (initlabeldb(NULL) != 0) {
 fprintf(stderr, "Could not read the Label Encodings Database.\n");
 exit(ERROR);
 }
 priv_remove(PV LAB_LEF, -1);

 /* Convert the passed SL to binary format */
 if (slhrtob(&sl1, argv[1]) != 0) {
 fprintf(stderr, "Unable to convert %s to binary form.\n", argv[1]);
 exit(ERROR);
 }
 if (slhrtob(&sl2, argv[2]) != 0) {
 fprintf(stderr, "Unable to convert %s to binary form.\n", argv[2]);
 exit(ERROR);
 }
}

```

```

/* malloc for the maximum SL label length that can be formed */
slBuffer1 = (char *) malloc(maxlen_sl());
slBuffer2 = (char *) malloc(maxlen_sl());

if ((slBuffer1 == NULL) || (slBuffer2 == NULL)) {
 perror("malloc");
 exit(ERROR);
}

/*
 * Translate the label back to human readable (long) form.
 * This is not a necessary step. It is shown as an example
 * usage of slbtohr() API.
 */
if (slbtohr(slBuffer1, &sl1, HR_LONG) != 0) {
 fprintf(stderr, "Unable to convert to binary human readable form.\n");
 exit(ERROR);
}

if (slbtohr(slBuffer2, &sl2, HR_LONG) != 0) {
 fprintf(stderr, "Unable to convert to binary human readable form.\n");
 exit(ERROR);
}

/*
 * Use sl_cmp() to compare the dominance of the two labels.
 */
if (sl_cmp(&sl1, &sl2) == LAB_SAME) {
 printf("label (%s) equals label (%s).\n",
 slBuffer1, slBuffer2);
}
else if (sl_cmp(&sl1, &sl2) == LAB_DOM) {
 printf("label (%s) dominates label (%s).\n",
 slBuffer1, slBuffer2);
}
else if (sl_cmp(&sl2, &sl1) == LAB_DOM) {
 printf("label (%s) dominates label (%s).\n",
 slBuffer2, slBuffer1);
}
else {
 printf("The two labels are disjoint.\n");
}

return (SUCCESS);
}

```

### *Setting audit information example:*

This program retrieves and sets audit information.

The following privileges are required in the program's innate privilege set:

- **PV\_AU\_ADMIN**
- **PV\_DAC\_GID**

```

#include <sys/types.h>
#include <sys/priv.h>
#include <sys/audit.h>

char buf[1024];
int main(int argc, char *argv[])
{
 int rc, len, p;
 /* *Get process audit preselection mask */
 priv_raise(PV_AU_ADMIN, -1);
 rc = auditproc(0, AUDIT_QEVENTS, buf, sizeof (buf));
 priv_lower(PV_AU_ADMIN, -1);
}

```

```

if (rc)
 fprintf(stderr, "Failed to get audit info\n");
 /* *Add the `kernel audit class to the preselection mask */
p = 0;
while ((len = strlen(&buf;[p])) > 0)
 p += len + 1;
 strncat(&buf;[p], "kernel", (sizeof(buf)-p-1));
p += strlen("kernel") + 2;
buf[p] = 0;
priv_raise(PV_AU_ADMIN, -1);
rc = auditproc(0, AUDIT_EVENTS, buf, p);

priv_lower(PV_AU_ADMIN, -1);
if (rc)
 fprintf(stderr, "Failed to set audit info\n");
/* *Set the GID of the process to generate an audit record */
priv_raise(PV_DAC_GID, -1);
rc = setgid(129);
priv_lower(PV_DAC_GID, -1);
if (rc)
 fprintf(stderr, "Failed to setgid\n");
exit(0);
}

```

*Client example:*

This program sends two messages to the server, one using the standard **write** routine and the other using the **ewrite** routine.

The secure message is sent at SECRET. Note that the insecure message sent using the **write** call is given a default set of security attributes, which are configurable via netrule.

The following privileges are required in the program's innate privilege set:

- **PV\_LAB\_LEF**
- **PV\_MAC\_CL**
- **PV\_LAB\_SLUG\_STR**

```

#include <sys/mac.h>
#include <sys/socket.h>
#include <netinet/in.h>
#include <sys/priv.h>
#include <sys/secattr.h>
#include <errno.h>
#include <stdio.h>
#define SECURE 1
int
main(int argc, char *argv[])
{
 int sockfd;
 int uid, gid;
 char buf[BUFSIZ];

 struct sockaddr_in serv_addr;

#ifdef SECURE
 int l_init_result = 0;

 int ewrite_result = 0;

 sec_labels_t seclab;
#endif /*SECURE*/

```

```

uid = getuid();
gid = getgid();

if (argc != 3)
{
 fprintf(stderr, "Usage:%s: ADDR PORT\n", argv[0]);
 exit(1);
}
#ifdef SECURE
/*
 * * Gain access to the Label Encodings Database
 *
 * */

priv_raise(PV_LAB_LEF,-1);
l_init_result = initlabeldb(NULL);
if (priv_remove(PV_LAB_LEF, -1) != 0)
{
 fprintf(stderr, "Privilege Failure\n");
 exit(1);
}
if (l_init_result != 0)
{
 fprintf(stderr, "Could not read the Label Encodings Database\n");
 exit(0);
}
#endif /*SECURE*/
/*
 * * Fill in the structure "serv_addr" with the address
 * of
 * * the server that we want to connect with.
 * */
memset ((char *) &serv_addr;, '\0', sizeof(serv_addr));
serv_addr.sin_family = AF_INET;
serv_addr.sin_addr.s_addr = inet_addr(argv[1]);
serv_addr.sin_port = htons(atoi(argv[2]));
/* Open a TCP socket (an Internet stream socket). */
if ((sockfd = socket(AF_INET, SOCK_STREAM, 0)) < 0)
{
 perror("tcpclient: ");
 fprintf(stderr, "client: Cant open stream socket\n");
 exit(0);
}
if (connect(sockfd, (struct sockaddr *) &serv_addr;,
 sizeof(serv_addr)) < 0)
{
 perror("tcpclient: ");
 fprintf(stderr, "client: Cant connect to server\n");
 exit(0);
}
/*
 * * Send a normal write to the server, which will be
 * * assigned default security attributes
 * */
strcpy(buf, "This has the default security attributes.\n");
if (write(sockfd, buf, strlen(buf)+1) == -1)
{
 perror("tcpclient: ");
 fprintf(stderr, "write error\n");
}
#endif SECURE

```

```

 strcpy(buf, "This message is at SECRET\n");
/* Setup the SL and CLs */
slhrtob(&seclab.sl;, "SECRET");
slhrtob(&seclab.sl_cl_min;, "SECRET");
slhrtob(&seclab.sl_cl_max;, "SECRET A B");
seclab.sl.sl_format = STDSL_FORMAT;
seclab.sl_cl_min.sl_format = STDSL_FORMAT;
seclab.sl_cl_max.sl_format = STDSL_FORMAT;
/* This ewrite call needs PV_MAC_CL and PV_LAB_SLUG_STR */
priv_raise(PV_MAC_CL,PV_LAB_SLUG_STR,-1);
ewrite_result = ewrite(sockfd, buf,strlen(buf)+1, &seclab);
priv_lower(PV_MAC_CL,PV_LAB_SLUG_STR,-1);

if (ewrite_result == -1)
{
 perror("tcpclient call");
 fprintf(stderr, "ewrite error\n");
}
fflush(stderr);
#endif /*SECURE*/
fprintf(stderr, "exiting \n");
sleep(3);
close(sockfd);
exit(0);
}

```

#### *Server example:*

This program acts as a server and uses the **eread** routine to receive messages that are sent to its port. After successfully receiving a message, this program outputs the security attributes of the message.

The following privileges are required in the program's innate privilege set (without assigning FSF\_EPS secflags):

- **PV\_LAB\_LEF**
- **PV\_MAC\_CL**
- **PV\_MAC\_R\_STR**

```

#include <sys/mac.h>
#include <sys/socket.h>
#include <sys/priv.h>
#include <sys/secattr.h>
#include <sys/stropts.h>
#include <netinet/in.h>
#include <errno.h>
#include <stropts.h>
#include <unistd.h>
#include <stdio.h>
#include <m1s/m1s.h>
#define MAX_HR_LABEL_LEN 2048
#define SECURE 1
int
main(int argc, char *argv[])
{
 pid_t childpid;
 uint clen;
 int sockfd, newsockfd;
 struct sockaddr_in cli_addr, serv_addr;

#ifdef SECURE
 int l_init_result;
 char l_label_str[MAX_HR_LABEL_LEN];
 sec_labels_t seclab;
#endif /* SECURE */
 if (argc != 2)

```

```

{
 fprintf(stderr, "Usage:%s PORT\n", argv[0]);
 exit(1);
}
#ifdef SECURE
priv_raise(PV_LAB_LEF, -1);
l_init_result = initlabeldb(NULL);
if (priv_remove(PV_LAB_LEF, -1) != 0)
{
 fprintf(stderr, "Privilege Failure\n");
 exit(1);
}

if (l_init_result != 0)
{
 fprintf(stderr, "Could not read the Label Encodings Database\n");
 exit(1);
}
#endif /* SECURE */
/* Open a TCP socket (an Internet stream socket). */
if ((sockfd = socket(AF_INET, SOCK_STREAM, 0)) < 0)
{
 perror("tcpserver: ");
 fprintf(stderr, "server: Cant open stream socket\n");
 exit(1);
}
/*Bind our local address so that the client can send to us*/
memset((char *) &serv_addr;, '\0', sizeof(serv_addr));
serv_addr.sin_family = AF_INET;
serv_addr.sin_addr.s_addr = htonl(INADDR_ANY);
serv_addr.sin_port = htons(atoi(argv[1]));
if (bind(sockfd, (struct sockaddr *) & serv_addr,
 sizeof(serv_addr)) < 0)
{
 perror("tcpserver: ");
 fprintf(stderr, "server: Cant bind local address\n");
 exit(0);
}
listen(sockfd, 5);
for (;;)
{
 /*
 * * Wait for a connection from a client process.
 * */
 fprintf(stdout, "Waiting for a connection from a client\n");
 cli_len = sizeof(cli_addr);
 newsockfd = eaccept(sockfd, (struct sockaddr *) & cli_addr,
 &cli_len;, &seclab);
 if (newsockfd < 0)
 {
 perror("tcpserver: ");
 fprintf(stderr, "server: accept error\n");
 }
 /* Print SL */
 if (slbtohr(label_str, &seclab.sl;, HR_SHORT) != 0)
 {
 fprintf(stderr,"problem converting sl to string\n");
 }
 else
 {
 fprintf(stdout, "sl = %s.\n",label_str);
 }
 /* Print MIN CLEARANCE */
 if (slbtohr(label_str, &seclab.sl_cl_min;, HR_SHORT) != 0)
 {
 fprintf(stderr,"problem converting min clearance to string\n");
 }
}

```



```

else
{
 fprintf(stdout, "sl_cl_min = %s.\n",label_str);
}

/* Print MAX CLEARANCE */
if (slbtohr(label_str, &seclab.sl_cl_max;, HR_SHORT) != 0)
{
 fprintf(stderr,"problem converting max clearance to string\n");
}
else
{
 fprintf(stdout, "sl_cl_max = %s.\n",label_str);
}
if ((childpid = fork()) < 0)
{
 perror("tcpserver: ");
 fprintf(stderr, "server: fork error\n");
 exit(0);
}
else if (childpid == 0) /* child process */
{
 int i, j;
 char buf[BUFSIZ];
#ifdef SECURE
 sec_labels_t e_seclab;
#endif /* SECURE */
 close(sockfd);
 for (;;)
 {
 int ret, flag;
 struct strbuf ctstr, dtstr;
 char ctbuf[2048], dtbuf[2048];
 ctstr.maxlen=2048;
 ctstr.buf = ctbuf;
 dtstr.maxlen=2048;
 dtstr.buf = dtbuf;
#ifdef SECURE
 fprintf(stdout, "Calling eread\n");
 priv_raise(PV_MAC_CL,PV_MAC_R_STR,-1);
 ret = eread(newsockfd, buf, sizeof(buf),&e_seclab);
 priv_lower(PV_MAC_CL,PV_MAC_R_STR,-1);
 if (ret < 1)
 {
 if (ret == -1)
 fprintf(stderr, "eread error\n");
 else
 fprintf(stderr, "eread no data\n");
 close(newsockfd);
 exit(ret);
 }
 fprintf(stdout, "\n%s", buf);
 fprintf(stdout, "\n");
 /* Print SL */
 if (slbtohr(label_str, &e_seclab.sl;, HR_SHORT) != 0)
 {
 fprintf(stderr, "problem converting sl to string\n");
 }
 else
 {
 fprintf(stdout, "sl = %s.\n",label_str);
 }
 /* Print MIN CLEARANCE */
 if (slbtohr(label_str,&e_seclab.sl_cl_min;,HR_SHORT)!= 0)
 {
 fprintf(stderr,"problem converting min CL to string\n");
 }
 }
}

```

```

 else
 {
fprintf(stdout, "sl_cl_min = %s.\n",label_str);
 }
 /* Print MAX CLEARANCE */
 if (slbtohr(label_str,&e_seclab.sl_cl_max;,HR_SHORT) !=0)
 {
fprintf(stderr,"problem converting max CL to string\n");
 }
 else
 {
fprintf(stdout, "sl_cl_max = %s.\n",label_str);
 }
 fflush(stdout);
#else /* NOT SECURE */
 fprintf(stdout, "Calling read\n");
 if (read(newsockfd, buf, sizeof(buf)) < 1)
 {
 if (ret == -1)
 fprintf(stderr, "read error\n");
 else
 fprintf(stderr, "read no data\n");
 close(newsockfd);
 exit(ret);
 }
 fprintf(stdout, "%s\n", buf);
 fflush(stdout);
#endif /* NOT SECURE */
 }
}
/* parent process */
close(newsockfd);
}
}

```

#### *Trusted AIX user and port security attributes:*

User and port security attributes are used to retrieve the clearance attributes of users and ports and compare the user's clearance attributes against the ports.

The following additional attributes are defined in the **usersec.h** file for Trusted AIX.

#### **S\_MINSL**

Minimum sensitivity clearance label of the user. Type SEC\_CHAR

#### **S\_MAXSL**

Maximum sensitivity clearance label of the user. Type SEC\_CHAR

#### **S\_DEFSL**

Default sensitivity label of the user. Type SEC\_CHAR

#### **S\_MINTL**

Minimum integrity clearance label of the user. Type SEC\_CHAR.

#### **S\_MAXTL**

Maximum integrity clearance label of the user. Type SEC\_CHAR.

#### **S\_DEFTL**

Default integrity label of the user. Type SEC\_CHAR

The following attributes are valid for ports.

#### **S\_MINSL**

Minimum sensitivity label assigned to the port. Type SEC\_CHAR.

## S\_MAXSL

Maximum sensitivity label assigned to the port. Type SEC\_CHAR

## S\_TL

Integrity label assigned to the port. Type SEC\_CHAR

The following example determines if a user can login on the specified port.

```
#include <mls/mls.h>
#include <usersec.h>
#include <stdio.h>
#include <errno.h>

struct userlabels {
 sl_t minsl;
 sl_t maxsl;
 sl_t defsl;
 tl_t mintl;
 tl_t maxtl;
 tl_t deftl;
};

struct portlabels {
 sl_t minsl;
 sl_t maxsl;
 tl_t tl;
};

void getuserlabels(char * username, struct userlabels *usrlab);
void getportlabels(char * portname, struct portlabels *portlab);
void displayuseraccess(char * username, struct userlabels *usrlab,
 struct portlabels *portlab);

int
main (int argc, char **argv)
{
 struct userlabels usrlab;
 struct portlabels portlab;
 char *username = NULL;
 char *portname = NULL;

 if (argc != 3) {
 fprintf (stderr, "Usage: %s <username> <portname>\n", argv[0]);
 exit(1);
 }
 username = argv[1];
 portname = argv[2];

 initlabeldb(NULL);
 getuserlabels(username, &usrlab);
 getportlabels(portname, &portlab);
 displayuseraccess(username , &usrlab;, &portlab);
 endlabeldb();
}

void getuserlabels(char *username, struct userlabels *userlab)
{
 dbattr_t attributes[6];
 memset (attributes, 0, sizeof(attributes));

 attributes[0].attr_name = S_MINSL;
 attributes[0].attr_type = SEC_CHAR;

 attributes[1].attr_name = S_MAXSL;
 attributes[1].attr_type = SEC_CHAR;
```

```

attributes[2].attr_name = S_DEFSL;
attributes[2].attr_type = SEC_CHAR;

attributes[3].attr_name = S_MINTL;
attributes[3].attr_type = SEC_CHAR;

attributes[4].attr_name = S_MAXTL;
attributes[4].attr_type = SEC_CHAR;

attributes[5].attr_name = S_DEFTL;
attributes[5].attr_type = SEC_CHAR;

if (getuserattrs(username, attributes, 6)) {
 fprintf(stderr,
 "Error retrieving attributes for user %s\n", username);
 exit (1);
}

if (clhrtob (&(userlab->minsl), attributes[0].attr_char)) {
 fprintf(stderr, "minsl conversion error\n");
 exit (1);
}

if (clhrtob(&(userlab->maxsl), attributes[1].attr_char)) {
 fprintf(stderr, "maxsl conversion error\n");
 exit (1);
}

if (clhrtob(&(userlab->defsl), attributes[2].attr_char)) {
 fprintf(stderr, "defsl conversion error\n");
 exit (1);
}

if (tlhrtob(&(userlab->mintl), attributes[3].attr_char)) {
 fprintf(stderr, "mintl conversion error\n");
 exit (1);
}

if (tlhrtob(&(userlab->maxtl), attributes[4].attr_char)) {
 fprintf(stderr, "maxtl conversion error\n");
 exit (1);
}

if (tlhrtob(&(userlab->deftl), attributes[5].attr_char)) {
 fprintf(stderr, "deftl conversion error\n");
 exit (1);
}

printf("User %s has the following clearance values\n", username);
printf("minsl:%s\n", attributes[0].attr_char);
printf("maxsl:%s\n", attributes[1].attr_char);
printf("defsl:%s\n", attributes[2].attr_char);
printf("mintl:%s\n", attributes[3].attr_char);
printf("maxtl:%s\n", attributes[4].attr_char);
printf("deftl:%s\n", attributes[5].attr_char);

return;
}

void getportlabels(char *portname, struct portlabels *portlab)
{
 int rc =0;
 char *val = NULL;
 if ((rc = getportattr(portname,S_MINSL,(char*)&val;, SEC_CHAR)) != 0) {
 perror ("Error retrieving port attributes");
 exit(1);
 }
}

```

```

}

if (slhrtob(&(portlab->minsl), val)) {
 fprintf(stderr, "port minsl conversion error\n");
 exit (1);
}

if ((rc = getportattr(portname,S_MAXSL, (char*)&val;, SEC_CHAR)) != 0) {
 perror ("Error retrieving port attributes");
 exit(1);
}

if (slhrtob(&(portlab->maxsl), val)) {
 fprintf(stderr, "port maxsl conversion error\n");
 exit (1);
}

if ((rc = getportattr(portname,S_TL, (char*)&val;, SEC_CHAR)) != 0) {
 perror ("Error retrieving port attributes");
}

if (tlhrtob(&(portlab->t1), val)) {
 fprintf(stderr, "port t1 conversion error\n");
 exit (1);
}

return;
}

void displayuseraccess (char *username, struct userlabels *usrlab, struct portlabels *portlab)
{
 CMP_RES_T cmpres;
 cmpres = sl_cmp(&(usrlab->defsl), &(portlab->minsl));
 if (cmpres != LAB_DOM && cmpres != LAB_SAME) {
 printf("Default SL of user does not dominate the minimum SL of tty \n");
 exit(1);
 }

 cmpres = sl_cmp(&(portlab->maxsl), &(usrlab->defsl));
 if (cmpres != LAB_DOM && cmpres != LAB_SAME) {
 printf("Default SL of user is not dominated by maximum SL of tty \n");
 exit(1);
 }

 cmpres = tl_cmp(&(portlab->t1), &(usrlab->deft1));
 if (cmpres != LAB_SAME) {
 printf("Default TL of user is not same as TL of tty \n");
 exit(1);
 }

 printf("The user can login on the specified port\n");
 return;
}

```

### *Trusted AIX system calls:*

System calls are provided to manipulate additional Trusted AIX functionality.

#### **accept**

Accepts a connection on a socket

**ebind** Binds extended to handle security attributes

#### **connect**

Initiates a connection on a socket extended to handle security attributes

**eread** Reads from a stream and retrieve the message security attributes

**ereadv**  
Reads from a stream and retrieve the message security attributes

**erecv** recv, recvfrom, recvmsg extended to handle security attributes

**erecvfrom**  
recv, recvfrom, recvmsg extended to handle security attributes

**erecvmsg**  
recv, recvfrom, recvmsg extended to handle security attributes

**esend** send, sendto, sendmsg extended to handle security attributes

**esendmsg**  
send, sendto, sendmsg extended to handle security attributes

**esendto**  
send, sendto, sendmsg extended to handle security attributes

**ewrite** Writes to a stream and set the message security attributes

**ewritev**  
Writes to a stream and set the message security attributes

**sec\_getmsgsec**  
Gets security attributes of message queues

**sec\_getpsec**  
Gets the security information associated with a process

**sec\_getrunmode**  
Retrieves the kernel's mode of operation

**sec\_getsecconf**  
Returns the current security configuration flags

**sec\_getsemsec**  
Gets security attributes of semaphores

**sec\_getshmsec**  
Gets security attributes of shared memory segments

**sec\_getsyslab**  
Gets the default system sensitivity labels

**sec\_getlibbufsize**  
Retrieves library path entries in kernel

**sec\_getlibpath**  
Retrieves library path entries in kernel

**pdmkdir**  
Makes/sets/unsets a partitioned directory or subdirectory

**sec\_setauditrange**  
Sets the system global audit label range

**sec\_setplab**  
Sets the effective sensitivity label, minimum sensitivity clearance, maximum sensitivity clearance, and integrity label of the specified process

**setppdmode**  
Sets the partitioned directory mode (real or virtual) of the process

**setpriv**  
Sets the privilege sets associated with a process

**sec\_setptlibmode**  
Sets the TLIB mode of the process

**sec\_setrunmode**  
Sets the kernel's mode of operation

**sec\_setsecconf**  
Sets the kernel security configuration flags

**sec\_setsemlab**  
Sets security attributes of semaphores

**sec\_setshmlab**  
Sets security attributes of shared memory segments

**sec\_setsyslab**  
Sets the default system sensitivity, information, and integrity labels

*AIX C library functions:*

Subroutines and macros are provided to manipulate additional Trusted AIX functionality.

**accreange**  
Determine if a sensitivity label is within accreditation range.

**clbtohr**  
Convert the given binary clearance label to human readable format

**clhrtob**  
Convert the given human readable clearance label to binary format

**getfsbitindex, getfsbitstring**  
Routines to get the File Security flag Strings and indices

**getmax\_sl, getmax\_tl**  
Retrieve maximum sensitivity and integrity labels from the Label Encoding file.

**getmin\_sl, getmin\_tl**  
Retrieve minimum sensitivity and integrity labels from the Label Encoding file.

**getsecconfig, setsecconfig**  
Routines to retrieve and set the kernel security configuration flags for the runmodes

**initlabeldb, endlabeldb**  
Label Database initialization and termination routines.

**maxlen\_sl, maxlen\_cl, maxlen\_tl**  
Retrieve maximum length of Human readable labels based on the initialized Label Encoding file.

**priv\_isnull**  
Determines if any privileges are set in the given privilege set

**priv\_lower**  
Privilege set operations

**priv\_raise**  
Privilege set operations

**priv\_remove**  
Privilege set operations

**priv\_subset**  
Privilege set operations

**privbit\_clr**  
Clears a specified privilege in the specified privilege set

**priv\_clrall**  
Clears all privileges in the specified privilege set

**priv\_comb**  
Combines the first two specified privilege sets and places the result in the third specified privilege set

**priv\_copy**  
Copies the first specified privilege set into the second specified privilege set

**priv\_isnull**  
Determines if no privileges are set in the given privilege set

**priv\_mask**  
Computes the intersection of the first two specified privilege sets and places the result in the third specified privilege set

**priv\_rem**  
Removes the privileges in the second specified privilege set from the first specified privilege set and places the result in the third specified privilege set

**privbit\_set**  
Sets the specified privilege in the specified privilege set

**priv\_setall**  
Sets all privileges in the specified privilege set

**priv\_subset**  
Determines if the first specified privilege set is a subset of the second specified privilege set

**privbit\_test**  
Tests to see if the specified privilege is set in the specified privilege set

**slbtohr, clbtohr, tlbtohr**  
Binary Label to Human readable conversion routines.

**slhrtob, clhrtob, tlhrtob**  
Human readable to Binary Label conversion routines

**sl\_clr, tl\_clr**  
Routines to reset the labels

**sl\_cmp, tl\_cmp**  
Label comparison routines

**tl\_cmp**  
Compare integrity labels

## Trusted AIX privileges

The following privileges are available on Trusted AIX. A synopsis and description of each privilege and its uses is provided. Some privileges form a hierarchy, where one privilege can grant all of the rights associated with another privilege.

When checking for privileges, the system first checks to determine if the process has the lowest privilege needed, and then proceeds up the hierarchy checking for the presence of more powerful privileges. For example, a process with the **PV\_AU\_** privilege automatically has the **PV\_AU\_ADMIN**, **PV\_AU\_ADD**, **PV\_AU\_PROC**, **PV\_AU\_READ**, and **PV\_AU\_WRITE** privilege and a process with the **PV\_ROOT** privilege automatically has all of the privileges listed below except the **PV\_SU\_** privileges.

### *Audit privileges:*



The following audit privileges are available on Trusted AIX. A synopsis and description of each privilege and its uses is provided. Some privileges form a hierarchy, where one privilege can grant all of the rights associated with another privilege.

When checking for privileges, the system first checks to determine if the process has the lowest privilege needed, and then proceeds up the hierarchy checking for the presence of more powerful privileges. For example, a process with the **PV\_AU\_** privilege automatically has the **PV\_AU\_ADMIN**, **PV\_AU\_ADD**, **PV\_AU\_PROC**, **PV\_AU\_READ**, and **PV\_AU\_WRITE** privilege and a process with the **PV\_ROOT** privilege automatically has all of the privileges listed below except the **PV\_SU\_** privileges.

**PV\_AU\_**

Equivalent to all of the other **PV\_AU\_** privileges combined

**PV\_AU\_ADD**

Allows a process to record/add an audit record

**PV\_AU\_ADMIN**

Allows a process to configure and query the audit system

**PV\_AU\_PROC**

Allows a process to get and set an audit state of a process

**PV\_AU\_READ**

Allows a process to read a file marked as an audit file

**PV\_AU\_WRITE**

Allows a process to write or delete a file marked as an audit file, or to mark a file as an audit file

***Authorization privileges:***

The following authorization privileges are available on Trusted AIX. A synopsis and description of each privilege and its uses is provided. Some privileges form a hierarchy, where one privilege can grant all of the rights associated with another privilege.

When checking for privileges, the system first checks to determine if the process has the lowest privilege needed, and then proceeds up the hierarchy checking for the presence of more powerful privileges. For example, a process with the **PV\_AU\_** privilege automatically has the **PV\_AU\_ADMIN**, **PV\_AU\_ADD**, **PV\_AU\_PROC**, **PV\_AU\_READ**, and **PV\_AU\_WRITE** privilege and a process with the **PV\_ROOT** privilege automatically has all of the privileges listed below except the **PV\_SU\_** privileges.

**PV\_AZ\_ADMIN**

Allows a process to modify the kernel security tables

**PV\_AZ\_READ**

Allows a process to retrieve the kernel security tables

**PV\_AZ\_ROOT**

Causes a process to pass authorization checks during an **exec** system call

**PV\_AZ\_CHECK**

Allows a process to pass all authorization checks

***DAC privileges:***

The following DAC privileges are available on Trusted AIX. A synopsis and description of each privilege and its uses is provided. Some privileges form a hierarchy, where one privilege can grant all of the rights associated with another privilege.

When checking for privileges, the system first checks to determine if the process has the lowest privilege needed, and then proceeds up the hierarchy checking for the presence of more powerful privileges. For example, a process with the **PV\_AU\_** privilege automatically has the **PV\_AU\_ADMIN**, **PV\_AU\_ADD**,

**PV\_AU\_PROC**, **PV\_AU\_READ**, and **PV\_AU\_WRITE** privilege and a process with the **PV\_ROOT** privilege automatically has all of the privileges listed below except the **PV\_SU\_** privileges.

**PV\_DAC\_**

Equivalent to all of the other **PV\_DAC\_** privileges combined

**PV\_DAC\_O**

Allows a process to override DAC ownership restrictions

**PV\_DAC\_R**

Allows a process to override DAC read restrictions

**PV\_DAC\_W**

Allows a process to override DAC write restrictions

**PV\_DAC\_X**

Allows a process to override DAC execute restriction

**PV\_DAC\_UID**

Allows a process to set or change its user ID (UID)

**PV\_DAC\_GID**

Allows a process to set or change its group ID (GID)

**PV\_DAC\_RID**

Allows a process to set or change its role ID (RID)

**Filesystem privileges:**

The following filesystem privileges are available on Trusted AIX. A synopsis and description of each privilege and its uses is provided. Some privileges form a hierarchy, where one privilege can grant all of the rights associated with another privilege.

When checking for privileges, the system first checks to determine if the process has the lowest privilege needed, and then proceeds up the hierarchy checking for the presence of more powerful privileges. For example, a process with the **PV\_AU\_** privilege automatically has the **PV\_AU\_ADMIN**, **PV\_AU\_ADD**, **PV\_AU\_PROC**, **PV\_AU\_READ**, and **PV\_AU\_WRITE** privilege and a process with the **PV\_ROOT** privilege automatically has all of the privileges listed below except the **PV\_SU\_** privileges.

**PV\_FS\_**

Equivalent to all of the other **PV\_FS\_** privileges combined

**PV\_FS\_MKNOD**

Allows a process to perform the **mknod** system call to create a file of any type.

**PV\_FS\_MOUNT**

Allows a process to mount and unmount a filesystem

**PV\_FS\_CHOWN**

Allows a process to change the ownership of a file

**PV\_FS\_QUOTA**

Allows a process to manage information related to disk quotas

**PV\_FS\_LINKDIR**

Allows a process to make a hard link to a directory

**PV\_FS\_RESIZE**

Allows a process to perform extend and shrink type operations on a filesystem

**PV\_FS\_CNTL**

Allows a process to perform various control operations, except extend and shrink operations, on filesystems

**PV\_FS\_CHROOT**

Allows a process to change its root directory

**PV\_FS\_PDMODE**

Allows a process to make or set a partitioned-type directory

***Process privileges:***

The following process privileges are available on Trusted AIX. A synopsis and description of each privilege and its uses is provided. Some privileges form a hierarchy, where one privilege can grant all of the rights associated with another privilege.

When checking for privileges, the system first checks to determine if the process has the lowest privilege needed, and then proceeds up the hierarchy checking for the presence of more powerful privileges. For example, a process with the **PV\_AU\_** privilege automatically has the **PV\_AU\_ADMIN**, **PV\_AU\_ADD**, **PV\_AU\_PROC**, **PV\_AU\_READ**, and **PV\_AU\_WRITE** privilege and a process with the **PV\_ROOT** privilege automatically has all of the privileges listed below except the **PV\_SU\_** privileges.

**PV\_PROC\_**

Equivalent to all of the other **PV\_PROC\_** privileges combined

**PV\_PROC\_PRIO**

Allows a process/thread to change priority, policy, and other scheduling parameters

**PV\_PROC\_CORE**

Allows a process to dump core

**PV\_PROC\_RAC**

Allows a process to create more processes than the per-user limit

**PV\_PROC\_RSET**

Allows to attach resource set (**rset**) to a process or thread

**PV\_PROC\_ENV**

Allows a process to set user information in the user structure

**PV\_PROC\_CKPT**

Allows a process to checkpoint or restart another process

**PV\_PROC\_CRED**

Allows a process to set process credential attributes

**PV\_PROC\_SIG**

Allows a process to send a signal to an unrelated process

**PV\_PROC\_PRIV**

Allows a process to modify or view privilege sets associated with a process

**PV\_PROC\_TIMER**

Allows a process to submit and use fine granularity timers

**PV\_PROC\_RTCLK**

Allows a process to access the CPU-time clock

**PV\_PROC\_VARS**

Allows a process to retrieve and update process tunable parameters

**PV\_PROC\_PDMODE**

Allows a process to change the REAL mode of partitioned directory

***Kernel privileges:***

The following kernel privileges are available on Trusted AIX. A synopsis and description of each privilege and its uses is provided. Some privileges form a hierarchy, where one privilege can grant all of the rights associated with another privilege.

When checking for privileges, the system first checks to determine if the process has the lowest privilege needed, and then proceeds up the hierarchy checking for the presence of more powerful privileges. For example, a process with the **PV\_AU\_** privilege automatically has the **PV\_AU\_ADMIN**, **PV\_AU\_ADD**, **PV\_AU\_PROC**, **PV\_AU\_READ**, and **PV\_AU\_WRITE** privilege and a process with the **PV\_ROOT** privilege automatically has all of the privileges listed below except the **PV\_SU\_** privileges.

**PV\_KER\_**

Equivalent to all of the other **PV\_KER\_** privileges combined

**PV\_KER\_ACCT**

Allows a process to perform restricted operations related to the accounting subsystem

**PV\_KER\_DR**

Allows a process to invoke dynamic reconfiguration operations

**PV\_KER\_TIME**

Allows a process to modify the system clock and time

**PV\_KER\_RAC**

Allows a process to use large (non-pageable) pages for shared memory segments

**PV\_KER\_WLM**

Allows a process to initialize and modify WLM configuration

**PV\_KER\_EWLM**

Allows a process to initialize or query the eWLM environment

**PV\_KER\_VARS**

Allows a process to examine or set kernel run time tunable parameters

**PV\_KER\_REBOOT**

Allows a process to shut down the system

**PV\_KER\_RAS**

Allows a process to configure or write RAS records, error logging, tracing, and dump functions

**PV\_KER\_LVM**

Allows a process to configure the LVM subsystem

**PV\_KER\_NFS**

Allows a process to configure the NFS subsystem

**PV\_KER\_VMM**

Allows a process modify swap parameters and other VMM tunable parameters in the kernel

**PV\_KER\_WPAR**

Allows a process to configure a workload partition

**PV\_KER\_CONF**

Allows a process to perform various system configuration operations

**PV\_KER\_EXTCONF**

Allows a process to perform various configuration tasks in kernel extensions

**PV\_KER\_IPC**

Allows a process to raise the value of the IPC message queue buffer and allow **shmget** system calls with ranges to attach

**PV\_KER\_IPC\_R**

Allows a process to read an IPC message queue, semaphore set, or shared memory segment

**PV\_KER\_IPC\_W**

Allows a process to write an IPC message queue, semaphore set, or shared memory segment

**PV\_KER\_IPC\_O**

Allows a process to read override DAC ownership on all IPC objects

**PV\_KER\_SECCONFIG**

Allows a process to set kernel security flags

**PV\_KER\_PATCH**

Allows a process to patch kernel extensions

***Label privileges:***

The following label privileges are available on Trusted AIX. A synopsis and description of each privilege and its uses is provided. Some privileges form a hierarchy, where one privilege can grant all of the rights associated with another privilege.

When checking for privileges, the system first checks to determine if the process has the lowest privilege needed, and then proceeds up the hierarchy checking for the presence of more powerful privileges. For example, a process with the **PV\_AU\_** privilege automatically has the **PV\_AU\_ADMIN**, **PV\_AU\_ADD**, **PV\_AU\_PROC**, **PV\_AU\_READ**, and **PV\_AU\_WRITE** privilege and a process with the **PV\_ROOT** privilege automatically has all of the privileges listed below except the **PV\_SU\_** privileges.

**PV\_LAB\_**

Equivalent to all other label privileges (**PV\_LAB\_\***) combined

**PV\_LAB\_CL**

Allows a process to modify subject SCLs, subject to the clearance of the process

**PV\_LAB\_CLTL**

Allows a process to modify subject TCLs, subject to the clearance of the process

**PV\_LAB\_LEF**

Allows a process to read the labeling database

**PV\_LAB\_SLDG**

Allows a process to downgrade SLs, subject to the clearance of the process

**PV\_LAB\_SLDG\_STR**

Allows a process to downgrade the SL of a packet, subject to the clearance of the process

**PV\_LAB\_SL\_FILE**

Allows a process to change object SLs, subject to the clearance of the process

**PV\_LAB\_SL\_PROC**

Allows a process to change subject SL, subject to the clearance of the process

**PV\_LAB\_SL\_SELF**

Allows a process to change its own SL, subject to the clearance of the process

**PV\_LAB\_SLUG**

Allows a process to upgrade SLs, subject to the clearance of the process

**PV\_LAB\_SLUG\_STR**

Allows a process to upgrade the SL of a packet, subject to the clearance of the process

**PV\_LAB\_TL**

Allows a process to modify subject and object TLs

***MAC privileges:***

The following MAC privileges are available on Trusted AIX. A synopsis and description of each privilege and its uses is provided. Some privileges form a hierarchy, where one privilege can grant all of the rights associated with another privilege.

When checking for privileges, the system first checks to determine if the process has the lowest privilege needed, and then proceeds up the hierarchy checking for the presence of more powerful privileges. For example, a process with the **PV\_AU\_** privilege automatically has the **PV\_AU\_ADMIN**, **PV\_AU\_ADD**, **PV\_AU\_PROC**, **PV\_AU\_READ**, and **PV\_AU\_WRITE** privilege and a process with the **PV\_ROOT** privilege automatically has all of the privileges listed below except the **PV\_SU\_** privileges.

**PV\_MAC\_**

Equivalent to all other MAC privileges (**PV\_MAC\_\***) combined

**PV\_MAC\_CL**

Allows a process to bypass sensitivity clearance restrictions

**PV\_MAC\_R\_PROC**

Allows a process to bypass MAC read restrictions when getting information about a process, provided that the target process's label is within the clearance of the acting process

**PV\_MAC\_W\_PROC**

Allows a process to bypass MAC write restrictions when sending a signal to a process, provided that the target process's label is within the clearance of the acting process

**PV\_MAC\_R**

Allows a process to bypass MAC read restrictions

**PV\_MAC\_R\_CL**

Allows a process to bypass MAC read restrictions when the object's label is within the clearance of the process

**PV\_MAC\_R\_STR**

Allows a process to bypass MAC read restrictions when reading a message from a STREAM, provided that the message's label is within the clearance of the process

**PV\_MAC\_W**

Allows a process to bypass MAC write restrictions

**PV\_MAC\_W\_CL**

Allows a process to bypass MAC write restrictions when the object's label is within the clearance of the process

**PV\_MAC\_W\_DN**

Allows a process to bypass MAC write restrictions when the process label dominates the object's label and the object's label is within the clearance of the process

**PV\_MAC\_W\_UP**

Allows a process to bypass MAC write restrictions when the process label is dominated by the object's label and the object's label is within the clearance of the process

**PV\_MAC\_OVRRD**

Bypass MAC restrictions for files flagged as being exempt from MAC

***MIC privileges:***

The following MIC privileges are available on Trusted AIX. A synopsis and description of each privilege and its uses is provided. Some privileges form a hierarchy, where one privilege can grant all of the rights associated with another privilege.

When checking for privileges, the system first checks to determine if the process has the lowest privilege needed, and then proceeds up the hierarchy checking for the presence of more powerful privileges. For example, a process with the **PV\_AU\_** privilege automatically has the **PV\_AU\_ADMIN**, **PV\_AU\_ADD**,

**PV\_AU\_PROC**, **PV\_AU\_READ**, and **PV\_AU\_WRITE** privilege and a process with the **PV\_ROOT** privilege automatically has all of the privileges listed below except the **PV\_SU\_** privileges.

**PV\_MIC**

Allows a process to bypass integrity restrictions

**PV\_MIC\_CL**

Allows a process to bypass integrity clearance restrictions

**Network privileges:**

The following network privileges are available on Trusted AIX. A synopsis and description of each privilege and its uses is provided. Some privileges form a hierarchy, where one privilege can grant all of the rights associated with another privilege.

When checking for privileges, the system first checks to determine if the process has the lowest privilege needed, and then proceeds up the hierarchy checking for the presence of more powerful privileges. For example, a process with the **PV\_AU\_** privilege automatically has the **PV\_AU\_ADMIN**, **PV\_AU\_ADD**, **PV\_AU\_PROC**, **PV\_AU\_READ**, and **PV\_AU\_WRITE** privilege and a process with the **PV\_ROOT** privilege automatically has all of the privileges listed below except the **PV\_SU\_** privileges.

**PV\_NET\_**

Equivalent to all other network privileges (**PV\_NET\_\***) combined

**PV\_NET\_CNTL**

Allows a process to modify network tables

**PV\_NET\_PORT**

Allows a process to bind to a restricted port

**PV\_NET\_RAWSOCK**

Allows a process to have direct access to a network layer

**PV\_NET\_CONFIG**

Allows a process to configure networking parameters

**Superuser privileges:**

The following superuser privileges are available on Trusted AIX. A synopsis and description of each privilege and its uses is provided. Some privileges form a hierarchy, where one privilege can grant all of the rights associated with another privilege.

When checking for privileges, the system first checks to determine if the process has the lowest privilege needed, and then proceeds up the hierarchy checking for the presence of more powerful privileges. For example, a process with the **PV\_AU\_** privilege automatically has the **PV\_AU\_ADMIN**, **PV\_AU\_ADD**, **PV\_AU\_PROC**, **PV\_AU\_READ**, and **PV\_AU\_WRITE** privilege and a process with the **PV\_ROOT** privilege automatically has all of the privileges listed below except the **PV\_SU\_** privileges.

**PV\_SU\_**

Equivalent to all other super user privileges (**PV\_SU\_\***) combined

**PV\_SU\_ROOT**

Grants a process the equivalent of all privileges associated with standard superuser

**PV\_SU\_EMUL**

Grants a process the equivalent of all privileges associated with the standard superuser when the process UID is 0

**PV\_SU\_UID**

Causes the **getuid** system call to return 0

**Miscellaneous privileges:**

The following miscellaneous privileges are available on Trusted AIX. A synopsis and description of each privilege and its uses is provided. Some privileges form a hierarchy, where one privilege can grant all of the rights associated with another privilege.

When checking for privileges, the system first checks to determine if the process has the lowest privilege needed, and then proceeds up the hierarchy checking for the presence of more powerful privileges. For example, a process with the **PV\_AU\_** privilege automatically has the **PV\_AU\_ADMIN**, **PV\_AU\_ADD**, **PV\_AU\_PROC**, **PV\_AU\_READ**, and **PV\_AU\_WRITE** privilege and a process with the **PV\_ROOT** privilege automatically has all of the privileges listed below except the **PV\_SU\_** privileges.

**PV\_ROOT**

Grants a process the equivalent of all other privileges except **PV\_SU\_** (and the privileges that **PV\_SU\_** dominates)

**PV\_TCB**

Allows a process to modify the kernel trusted library paths

**PV\_TP**

Indicates that a process is a trusted path process and allows actions that are limited to trusted path processes

**PV\_TP\_SET**

Allows a process to set or clear the kernel trusted path flag

**PV\_WPAR\_CKPT**

Allows a process to perform checkpoint and restart operations in workload partitions

**PV\_DEV\_CONFIG**

Allows a process to configure system kernel extensions and devices

**PV\_DEV\_LOAD**

Allows a process to load and unload system kernel extensions and devices in the system

**PV\_DEV\_QUERY**

Allows a process to query kernel modules

## Troubleshooting Trusted AIX

The answers to common questions may help you troubleshoot Trusted AIX.

### How do I login to Trusted AIX?

Trusted AIX creates three administrative users during installation with appropriate roles as given below.

The passwords to these accounts have to be set when the system boots up the first time after Trusted AIX installation. If you installed the system in promptless mode from the network, the password to these default accounts are as below.

| User | Password |
|------|----------|
| isso | isso     |
| sa   | sa       |
| so   | so       |

### How do I su to root?

At the time of Trusted AIX installation, the **su** attribute of **root** is set to **false** so that no user can access this account. To access this account the default administrative users, **isso** and **sa**, will have to change this attribute of the root account to **true** using the **chuser** command.

If **su** is enabled to root and password for root account is not set, then any user on the system can access the root account. To avoid this, it is recommended that the password of the root account be set before resetting the **su** attribute



### **Should I create administrative users of my own or use the default administrative users?**

The default administrative users are only for setting up the system for customization purposes. It is highly recommended, but not necessary, that these accounts be used only as for customizing the system.

Create your own three administrative users with appropriate roles of `isso`, `sa`, and `so`, and delete or disable these default users.

### **Why can't I login to the system?**

If you try to login in as root (account with uid 0) or any account having uid less than 128, access will be denied. These accounts are referred to as system accounts. To access system accounts, you need to login as a non-system account user and `su` to the account.

### **Is any error related to the label encodings file displayed while logging in?**

If the label encodings file is corrupted you will have to enter single user mode as root user. The root account is accessible only in single user mode.

Verify that the label encodings file (`/etc/security/enc/LabelEncodings`) is proper with the `labck` command. If the file is improper, modify the file and recheck with the `labck` command before exiting the single user mode.

Run `trustchk` in interactive mode (`trustchk -t ALL`) to validate the state of the system.

### **Why can't I compile any program on Trusted AIX which uses Trusted AIX library APIs?**

The development toolkit is not installed by default. You will need to install the `bos.mls.adt` fileset from the installation media.

### **How do I correct changes that I made to privileges of commands that caused those commands to stop working correctly?**

Run `trustchk` in interactive mode (`trustchk -t`) for those commands to fix the privileges.

### **Why can't I access the /etc/security/enc directory?**

To access the `/etc/security/enc` directory the shell requires the `PV_LAB_LEF` and `PV_MAC_R` privileges. Assign these privileges to your shell.

### **How do I disable trustchk at boot.**

Remove or comment the `trustchk` line in the `/etc/rc.mls` script.

### **How do I prevent the system from prompting for boot authentication at every boot?**

You might have enabled boot authentication for your system. You can disable it using the SMIT menu from the Trusted AIX sub menu.

### **Why doesn't my change work when I attempt to change the SL of a file system object?**

There are several possibilities:

#### **Did /usr/sbin/settxattr return any error messages?**

If so, check those for further information. For example:

#### **Did you have permission to execute /usr/sbin/settxattr?**

If not, check your privileges and authorizations.

#### **Was the syntax correct?**

Refer the `settxattr` man page for syntax.

#### **Does the requested SL or its abbreviation exist?**

Requesting "con a b" will work on a system with a default Label Encodings file (`/etc/security/enc/LabelEncodings`), but requesting "conf a b" will not, even though both would seem logical abbreviations for "confidential compartment A compartment B."

#### **Did you need to use quotes for a multiple-word label?**

`settxattr -f sl=con <filename>` will work, `settxattr -f -a sl="con a b" <filename>` will work, but `settxattr -a sl=con a b <filename>` will not work.

### Did `setxattr` return any error messages?

If no error messages were returned, the file system object may be a symbolic link. If the object you were trying to change is a symbolic link, first determine whether you wish to change the SL of the link itself or the object that the link points to. `setxattr` does not follow links but instead sets the labels of the link itself.

### How do I install a third-party application so that it will work correctly on the system?

If you installed a third party application and it is not working correctly, it might be accessing certain restricted files or directories which might require extra privileges. After evaluating the need of the application to access these restricted objects, determine the privileges needed as below.

- Assign `PV_ROOT` to your shell
- Run `tracepriv -f -e <third party command>`

This will list the privilege required by the application. Add these to the privileged command database using the `setsecattr` command.

### Why can't I execute certain commands?

Since most of the commands are protected by authorizations, execution of some of the privileged commands will be allowed only if the invoking user has the corresponding authorization. It can be verified by identifying whether the authorization required for the command's execution exists in one of the roles activated for the current session.

Check your active authorizations with `ro1elist -ae` and the authorization required by the command using `lssecattr -c <command>`.

### Why don't some commands display labels properly.

Most of these commands rely on the file `/etc/security/enc/LabelEncodings` for conversion of labels to human readable form and vice-versa. If this file is corrupted, or has been modified, the commands may not function as intended.

## File security flags

The file security flags affect the way that files are accessed. These flags are stored as part of the extended attributes (EA) of the file itself. The file security flags are defined in the header file.

### FSF\_APPEND

File can only be appended to and not altered in operational mode.

### FSF\_AUDIT

The file is marked as part of the audit subsystem. To read or write these files, the process must have the `PV_AU_READ` or `PV_AU_WRITE` privileges respectively.

### FSF\_MAC\_EXMPT

EPS with the `PV_MAC_OVRRD` privilege ignores MAC restrictions when attempting to access the object.

### FSF\_PDIR

The directory is a partitioned directory.

### FSF\_PSDIR

The directory is a partitioned subdirectory.

### FSF\_PSSDIR

The directory is a partitioned sub-subdirectory.

### FSF\_TLIB

The object is marked as part of the Trusted Library. The machine must be running in configuration mode or the `trustedlib_enabled` kernel security flag must be OFF.

## **FSF\_TLIB\_PROC**

Processes marked as TLIB processes can only link to \*.so libraries that have the **TLIB** flag set. The system must be running in configuration mode or the **trustedlib\_enabled** kernel security flag must be OFF.

## **Trusted AIX commands**

Security-related commands are provided to manage a Trusted AIX system:

**labck** Verifies a LabelEncodings file

### **getsecconf**

Displays the kernel security flags

### **setsecconf**

Changes the Trusted AIX kernel security flags

### **getsyslab**

Shows the kernel maximum and minimum labels

### **setsyslab**

Sets the kernel maximum and minimum labels

### **getrunmode**

Displays the current running mode of the system

### **setrunmode**

Switches the running mode of the system

**pdlink** Links files across partitioned subdirectories

### **pdmkdir**

Creates partitioned directories and subdirectories

### **pdmode**

Returns the current partitioned directory access mode or runs a command with a specified partitioned directory access mode

### **pdrmdir**

Removes partitioned directories and associated subdirectories

**pdset** Sets/unsets partitioned (sub)directories

### **bootauth**

Verifies that an authorized user is booting the system

### **chuser**

Changes the user's clearance attributes

**lsuser** Displays the user's clearance attributes

**chsec** Changes the user's clearance attributes and port labels

**lssec** Displays the user's clearance attributes and port labels

### **trustchk**

Checks the attributes of files

### **lstxattr**

Displays the label and security flag attributes of files, processes, and IPC objects

### **settxattr**

Changes the label and security flag attributes of files, processes, and IPC objects



---

## Notices

This information was developed for products and services offered in the U.S.A.

IBM may not offer the products, services, or features discussed in this document in other countries. Consult your local IBM representative for information on the products and services currently available in your area. Any reference to an IBM product, program, or service is not intended to state or imply that only that IBM product, program, or service may be used. Any functionally equivalent product, program, or service that does not infringe any IBM intellectual property right may be used instead. However, it is the user's responsibility to evaluate and verify the operation of any non-IBM product, program, or service.

IBM may have patents or pending patent applications covering subject matter described in this document. The furnishing of this document does not give you any license to these patents. You can send license inquiries, in writing, to:

IBM Director of Licensing  
IBM Corporation  
North Castle Drive  
Armonk, NY 10504-1785  
U.S.A.

**The following paragraph does not apply to the United Kingdom or any other country where such provisions are inconsistent with local law:** INTERNATIONAL BUSINESS MACHINES CORPORATION PROVIDES THIS PUBLICATION "AS IS" WITHOUT WARRANTY OF ANY KIND, EITHER EXPRESS OR IMPLIED, INCLUDING, BUT NOT LIMITED TO, THE IMPLIED WARRANTIES OF NON-INFRINGEMENT, MERCHANTABILITY OR FITNESS FOR A PARTICULAR PURPOSE. Some states do not allow disclaimer of express or implied warranties in certain transactions, therefore, this statement may not apply to you.

This information could include technical inaccuracies or typographical errors. Changes are periodically made to the information herein; these changes will be incorporated in new editions of the publication. IBM may make improvements and/or changes in the product(s) and/or the program(s) described in this publication at any time without notice.

Licensees of this program who wish to have information about it for the purpose of enabling: (i) the exchange of information between independently created programs and other programs (including this one) and (ii) the mutual use of the information which has been exchanged, should contact:

IBM Corporation  
Dept. LRAS/Bldg. 003  
11400 Burnet Road  
Austin, TX 78758-3498  
U.S.A.

Such information may be available, subject to appropriate terms and conditions, including in some cases, payment of a fee.

The licensed program described in this document and all licensed material available for it are provided by IBM under terms of the IBM Customer Agreement, IBM International Program License Agreement or any equivalent agreement between us.

For license inquiries regarding double-byte (DBCS) information, contact the IBM Intellectual Property Department in your country or send inquiries, in writing, to:

IBM World Trade Asia Corporation  
Licensing  
2-31 Roppongi 3-chome, Minato-ku  
Tokyo 106, Japan

IBM may use or distribute any of the information you supply in any way it believes appropriate without incurring any obligation to you.

Information concerning non-IBM products was obtained from the suppliers of those products, their published announcements or other publicly available sources. IBM has not tested those products and cannot confirm the accuracy of performance, compatibility or any other claims related to non-IBM products. Questions on the capabilities of non-IBM products should be addressed to the suppliers of those products.

Any references in this information to non-IBM Web sites are provided for convenience only and do not in any manner serve as an endorsement of those Web sites. The materials at those Web sites are not part of the materials for this IBM product and use of those Web sites is at your own risk.

This information contains examples of data and reports used in daily business operations. To illustrate them as completely as possible, the examples include the names of individuals, companies, brands, and products. All of these names are fictitious and any similarity to the names and addresses used by an actual business enterprise is entirely coincidental.

---

## Trademarks

The following terms are trademarks of International Business Machines Corporation in the United States, other countries, or both:

- AIX
- AT
- DB2
- DFS
- eServer
- IBM
- Lotus Notes
- POWER3
- POWER4
- pSeries
- SecureWay
- SP
- Tivoli

UNIX is a registered trademark of The Open Group in the United States and other countries.

Java and all Java-based trademarks and logos are registered trademarks of Sun Microsystems, Inc. in the United States, other countries, or both.

Linux is a trademark of Linus Torvalds in the United States, other countries, or both.

Microsoft, Active Directory, and Windows are trademarks of Microsoft Corporation in the United States, other countries, or both.

Other company, product, or service names may be trademarks or service marks of others.

---

# Index

## Special characters

/dev/urandom 333  
/etc/publickey file 286  
/etc/radius/dictionary file 310  
/etc/radius/proxy file 311  
/usr/lib/security/audit/config 201  
/var/radius/data/accounting file 318  
.netrc 201

## A

access control  
    extended permissions 108  
    lists 106, 108  
access modes  
    base permissions 108  
access rights 278, 281  
Account ID 45  
Active Directory 294, 299  
    group member attribute selection 137  
    password attribute selection 136  
Active Directory through LDAP  
    configuring AIX 136  
adding a CA root digital certificate 236  
administrative rights 281  
AIX  
    configuring to work with Active Directory through LDAP 136  
AIX Security Expert 337, 339, 341, 345, 348, 349, 351, 353, 354, 358, 366, 368, 369, 374, 375, 378, 379, 380  
    /etc/inetd.conf settings 358  
    /etc/inittab entries 353  
    /etc/rc.tcpip settings 354  
Audit Policy Recommendations 351  
Check Security 378  
Disable Remote Services 366  
Disable SUID of Commands 366  
files 379  
High level security scenario 379  
IPsec filter rules 374  
login policy recommendations 349  
Low level security scenario 380  
Medium level security scenario 380  
Miscellaneous 375  
network security 337  
password policy rules 345  
Remove access that does not require Authentication 368  
reports 337  
security policy copy 341  
settings 337, 339, 341, 345, 348, 349, 351, 353, 354, 358, 366, 368, 369, 374, 375, 378, 379, 380  
system security 337, 339, 341, 345, 348, 349, 351, 353, 354, 358, 366, 368, 369, 374, 375, 378, 379, 380  
Tuning Network Options 369

AIX Security Expert (*continued*)  
    undo 337  
    Undo Security 378  
    user group system and password definitions group 348  
AIX Standard Settings 337  
aixpert command 337  
assigning privileges to a running process 95  
audit  
    record processing 121  
    watch command 125  
auditing  
    collecting event information 119  
    configuration of 120  
    detecting events 119  
    event selection 125  
    example, real-time file monitoring 129  
    kernel audit trail 119  
    kernel audit trail mode 121  
    logging  
        event selection 121  
    logging events  
        description of 120  
    overview 119  
    records format 120  
    setting up 126  
auditing integrity 9  
auditing session roles 95  
authentication 65, 276  
authentication for Windows servers  
    Kerberos 138  
authorization 278  
    and hierarchy 280  
    classes 278

## B

base permissions 108

## C

CAPP/EAL4+  
    see also Controlled Access Protection Profile and Evaluation Assurance Level 4+ and Labeled Security Protection Profile and Evaluation Assurance Level 4+ 12  
CAPP/EAL4+ and Network Installation Management (NIM) Environment 14  
CAPP/EAL4+ organizational environment 18  
CAPP/EAL4+ system physical environment 17  
Certificate Authentication Service  
    overview 156  
Certification Authority (CA)  
    adding root certificate to database 236  
    deleting root certificate from database 237  
    list of CAs 235  
    receiving certificate from 238

- Certification Authority (CA) *(continued)*
  - requesting certificate from 237
  - trust settings 236
- changing key database password 239
- chsec command 45
- commands
  - aixpert 337
- commands, LDAP 145
- Common Criteria
  - see also Controlled Access Protection Profile and Evaluation Assurance Level 4+ and Labeled Security Protection Profile and Evaluation Assurance Level 4+ 12
- configuration file, RADIUS 305
- Configuring security policies 10
- Controlled Access Protection Profile and Evaluation Assurance Level 4+ 13, 14
  - administrative interfaces 12
  - systems supported 12
  - user interfaces 12
- Controlled Access Protection Profile and Evaluation Assurance Level 4+ and Labeled Security Protection Profile and Evaluation Assurance Level 4+ 12
- Controlled Access Protection Profile and Evaluation Assurance Level 4+ compliant system 12
- creating a key database 235
- creating IKE tunnels with digital certificates 240
- credentials 276
  - DES 277
  - local 277

## D

- dacinet 206
- deleting a CA root digital certificate 237
- deleting a personal digital certificate 239
- DES credentials 277
- determining required privileges for a command 86
- digital certificates
  - adding root 236
  - creating IKE tunnels with 240
  - creating key database 235
  - deleting personal 239
  - deleting root 237
  - managing 235
  - receiving 238
  - requesting 237
  - trust settings 236
- disk quota system
  - overview 70
  - recovering from over-quota conditions 70
  - setting up 71
- dist\_uniqid 45

## E

- EIM
  - see also Enterprise Identity Mapping 289
- Enterprise Identity Mapping 289
  - current approach 291
- extended permissions 108

## F

- files
  - /etc/radius/clients 309
  - default.auth 317
  - default.policy 317
  - ldap.client 304
  - ldap.server 304
  - radius.base 304
  - user\_id.auth 317
- filters
  - relationship to tunnels 219
  - rules 215
- filters, setting up 246
- flags 37
- flags, SED 37
- Framed Pool Attribute 328
- ftp 292

## G

- generic data management tunnel
  - using Web-based System Manager 225
  - using XML 223
- group member attribute selection
  - Active Directory 137

## H

- High Level Security 337

## I

- identification 65
- IKE
  - features 213
- IKE tunnels
  - creating
    - using digital certificates 240
- Installing a CAPP/EAL+ system 13
- Installing a LSPP/EAL+ system 16
- Internet Engineering Task Force (IETF) 211
- Internet Key Exchange
  - see IKE 213
- Internet Protocol
  - security 212
    - features 212
    - IKE features 213
    - operating system 212
- Internet Protocol (IP) security 211
  - configuration 246
  - planning 217
  - installation 216
  - logging 252
  - predefined filter rules 251
  - problem determination 257
  - reference 265
- intrusion detection 334
  - filter rules
    - SMIT 336



- intrusion detection (*continued*)
  - patterns
    - types 334
  - rules
    - pattern matching 334
    - shun filter 335
    - shun host 335
    - stateful filter 335
- intrusion prevention 334
- IP
  - see Internet Protocol 212
- IP pooling 328
- IP security
  - filters 215
    - and tunnels 219
  - SAs 219
  - security associations 213
  - tunnels
    - and filters 219
    - and SAs 219
    - choosing which type 220
    - tunnels and key management 214
- IP Security
  - Digital Certificate Support 216
- IPv4
  - also see Internet Protocol (IP) security 211
- IPv6 211
- ITDS 135
  - Security Information Server
    - Setting Up 131

**K**

- kadmind daemon 298
- Kerberos 291
  - authenticating users to AIX 294
  - authentication for Windows servers 138
  - installing and configuring for Kerberos integrated
    - login using KRB5 294
  - installing and configuring for Kerberos integrated
    - login using KRB5A 299
  - secure rcmds
    - ftp 292
    - rcp 292
    - rlogin 292
    - rsh 292
    - telnet 292
- kerbos module 303
- kernel extensions
  - kerbos 303
- kernel security tables 89
- key database, establishing trust settings for 236
- key management
  - and tunnels 214
- Key Manager 235
- keylogin command
  - secure NFS 284
- keys
  - changing database password 239
  - creating a database 235
- KRB5 294

- KRB5A 299

## L

- LDAP
  - Auditing
    - Security Information Server 145
  - Client
    - Setting Up 133
    - communicating with 139, 141
    - Exploitation of the Security Subsystem 131
    - mksecdap 145
    - overview 130
    - User Management 138
  - LDAP Attribute Mapping 147
  - LDAP commands 145
  - LDAP netgroups 134
  - LDAP servers 135
  - ldap.cfg file format 146
  - Light Directory Access Protocol (See LDAP) 131
  - local credentials 277
  - logging IP Security 252
  - login control 32
    - changing the CDE login screen 34
    - changing the welcome message 33
    - enforcing automatic logoff 35
    - securing unattended terminals 35
    - setting up 33
    - tightening system default login parameters 35
  - login user ID 52, 65
  - Low Level Security 337
  - lsldap command 145
  - LSPP and Evaluation Assurance Level 4+ 16, 17
  - LSPP/EAL4+ and Network Installation Management (NIM) Environment 17
  - LSPP/EAL4+ configuration installation (only available with Trusted AIX) 16
  - LSPP/EAL4+ organizational environment 18
  - LSPP/EAL4+ system physical environment 17

**M**

- mechanism 36
- Medium Level Security 337
- mgrsecurity 46, 47, 58
- mkgroup command 45
- mksecdap command 145
- mkuser command 45
- modes and monitoring 36
- modes, SED 36
- monitoring, SED 36
- mount command
  - secure NFS
    - file systems 289
- multiple base DN support 139
- multiple organizational units 137

## N

- netgroups 134

- network
  - security 337
- Network Authentication Service 294, 299
- Network Authentication Service (NAS) 292
- network trusted computing base 204
- NFS (Network File System)
  - /etc/publickey file 286
  - secure NFS 282
    - administering 287
    - authentication requirements 284
    - configuring 288
    - file systems 289
    - how to export a file system 288
    - net name 286
    - network entities 286
    - performance 287
    - public key cryptography 284
- NIS+
  - principals 275
  - security 274
- NLS enablement 333

## O

- OpenSSH
  - configuration of compilation 195
  - installing and configuring 193
  - introduction 193
  - Kerberos Version 5 support 197
  - using with Kerberos Version 5 198
  - Web addresses 193
- operating system security 273
  - authentication 273
  - gates 273
  - secure RPC password 273

## P

- PAM
  - adding a module 192
  - changing the /etc/pam.conf file 192
  - configuration file
    - /etc/pam.conf 188
  - debug 192
  - introduction 185
  - library 186
  - loadable authentication module 190
  - modules 187
- password attribute selection
  - Active Directory 136
- passwords 58
  - /etc/password file 59
  - establishing good passwords 58
  - extending restrictions 65
  - recommended password options 60
  - secure RPC 273
- patterns
  - files 334
  - hexadecimal 334
  - text 334

- permissions
  - base 108
  - extended 108
- PKCS #11 153
  - subsystem configuration 154
  - usage 155
- PKI 156
- principals
  - security 275
- privilege naming and hierarchy 84
- privileged command database 85
- programs
  - setuid/setgid 39
- proxy server, configure 320
- proxy services, RADIUS 319
- public key cryptography
  - secure NFS 284
- Public Key Infrastructure 156

## Q

- quota system
  - see disk quota system 70

## R

- RADIUS 304
  - accounting 318
    - server operation 318
  - authentication 312
    - user databases 312
  - Authentication Methods
    - CHAP 316
    - EAP 317
    - PAP 316
  - authorization 317
  - configuration files 305
    - accounting 318
    - clients 309
    - dictionary 310
    - proxy 311
    - radiusd.conf file 305
  - configuring 322
  - installing 304
  - IP pool configuration 328
  - LDAP
    - active call list object class 316
    - name space overview 314
    - schema 315
    - user profile object class 316
  - LDAP server
    - configuration 314
  - local UNIX authentication 312
  - password expiration 327
  - protocol
    - supported standards 304
  - proxy
    - prefixes and suffixes 320
    - realm example 319
    - services 319

- RADIUS (*continued*)
  - proxy services
    - configuring 320
  - random number generator 333
  - Reply-Message support 328
  - SMIT panels 332
  - Starting and Stopping 304
  - utilities
    - logging 322
  - Vendor-Specific Attributes 327
- RADIUS server 328
- radiusd.conf file 305
- RBAC-aware applications 99
- rcp 292
- Remote Authentication Dial-In User Service 304
- rlogin 292
- root account 46
  - disabling direct root login 46
- root user processes
  - capabilities of 116
- rsh 292

## S

- SAK 5
- secdapclntd daemon 145
- secure attention key
  - configuring 5
- Secure Attention Key 11
- secure NFS 282
- secure RPC password 273
- security
  - account ID 45
  - configuration 337, 339, 345, 348, 349, 351, 353, 354, 358, 366, 368, 369, 374, 375, 378, 379, 380
  - Internet Protocol (IP) 211
  - introduction 1
    - administrative tasks 47, 58
  - network 337
  - NIS+ 274
    - administrative rights 281
    - authentication 274
    - authorization 274, 278
    - credentials 276
    - levels 275
    - principals 275
  - operating system 273
  - policy 341
  - root account 46
  - system 337, 339, 341, 345, 348, 349, 351, 353, 354, 358, 366, 368, 369, 374, 375, 378, 379, 380
  - TCP/IP 199
- security associations (SA) 213
  - relationship to tunnels 219
- security authentication 65
- security hardening 337, 339, 341, 345, 348, 349, 351, 353, 354, 358, 366, 368, 369, 374, 375, 378, 379, 380
- Security Parameters Index (SPI)
  - and security associations 213
- Security policies configuration 10

- security tables
  - kernel 89
- SED 35
- SED mechanism 36
- SED modes and monitoring 36
- Server
  - Security Information
    - ITDS 131
- setgid program
  - use of 115
- setgid programs 39
- setuid program
  - use of 115
- setuid programs 39
- Stack Execution Disable 35, 36, 37
- supported LDAP servers 135
- system security 337, 339, 341, 345, 348, 349, 351, 353, 354, 358, 366, 368, 369, 374, 375, 378, 379, 380
- system-defined authorizations 79

## T

- TCB 1
- tcbck command
  - configuring 5
  - using 3
- TCP/IP
  - /etc/ftpusers 203
  - /etc/hosts.equiv 202
  - /usr/lib/security/audit/config 201
  - .netrc 201
  - IP security
    - IKE features 213
    - installation 216
    - planning configuration 217
    - predefined filter rules 251
    - problem determination 257
    - reference 265
  - IP Security 211
    - security 199
      - data 205
      - DOD 205
      - NTCB 204
      - operating system-specific 199, 200
      - remote command execution access 202
      - restricted FTP users 203
      - SAK 200
      - TCP/IP-specific 201, 203
      - trusted shell 200
    - see Internet Protocol 212
- telnet 292
- trust settings for key database, establishing 236
- Trusted AIX
  - LSPP/EAL4+ configuration installation 16
- Trusted Communication Path
  - use of 5
- Trusted Computing Base
  - auditing of 120
  - auditing the security state of 2
  - checking with tcbck command 3

Trusted Computing Base *(continued)*  
file system  
  checking 3  
  overview 1  
  trusted files  
    checking 3  
    trusted program 4  
Trusted Computing Base Set  
  trusted files 6  
Trusted Execution 6  
Trusted Execution Path 11  
trusted file 7  
Trusted Library Path 11  
Trusted Shell 11  
Trusted Signature Database 7  
  auditing integrity 9  
tunnels  
  and key management 214  
  choosing which type 220  
  relationship to filters 219  
  relationship to SAs 219

## U

user account  
  control of 50  
User and group name length limit  
  configuring and retrieving 48  
  v\_max\_logname 48  
user authentication 65  
User Management  
  LDAP 138

## V

Vendor Specific Attribute 328  
Virtual Private Network (VPN) 211  
VPN  
  benefits 216

## X

XML 223, 225

---

# Readers' Comments — We'd Like to Hear from You

**AIX Version 6.1  
Security**

**Publication No. SC23-6603-00**

We appreciate your comments about this publication. Please comment on specific errors or omissions, accuracy, organization, subject matter, or completeness of this book. The comments you send should pertain to only the information in this manual or product and the way in which the information is presented.

For technical questions and information about products and prices, please contact your IBM branch office, your IBM business partner, or your authorized remarketer.

When you send comments to IBM, you grant IBM a nonexclusive right to use or distribute your comments in any way it believes appropriate without incurring any obligation to you. IBM or any other organizations will only use the personal information that you supply to contact you about the issues that you state on this form.

Comments:

Thank you for your support.

Submit your comments using one of these channels:

- Send your comments to the address on the reverse side of this form.
- Send your comments via e-mail to: [aix6koub@austin.ibm.com](mailto:aix6koub@austin.ibm.com)

If you would like a response from IBM, please fill in the following information:

\_\_\_\_\_  
Name

\_\_\_\_\_  
Address

\_\_\_\_\_  
Company or Organization

\_\_\_\_\_  
Phone No.

\_\_\_\_\_  
E-mail address



Fold and Tape

Please do not staple

Fold and Tape



NO POSTAGE  
NECESSARY  
IF MAILED IN THE  
UNITED STATES

# BUSINESS REPLY MAIL

FIRST-CLASS MAIL PERMIT NO. 40 ARMONK, NEW YORK

POSTAGE WILL BE PAID BY ADDRESSEE

IBM Corporation  
Information Development  
Department 04XA-905-6C006  
11501 Burnet Road  
Austin, TX 78758-3493



Fold and Tape

Please do not staple

Fold and Tape





Printed in U.S.A.

SC23-6603-00

