

Operations Guide

HP 9000 rp4410 and HP 9000 rp4440



Manufacturing Part Number: A9950-96002

Third Edition

April 2005

U.S.A.

© Copyright 2004-2005 Hewlett-Packard Development Company, L.P..

Legal Notices

Copyright Notices. © Copyright 2004-2005 Hewlett-Packard Development Company, L.P.

The information contained herein is subject to change without notice.

The only warranties for HP products and services are set forth in the express warranty statements accompanying such products and services. Nothing herein should be construed as constituting an additional warranty. HP shall not be liable for technical or editorial errors or omissions contained herein.

1. Controls, Ports, and Indicators

Introduction	11
Front Panel	12
Switch/Button and Front Control Panel LED Definitions	14
Additional Controls and Indicators	15
Hot-Plug Disk Drive Indicators	15
DVD-ROM/DVD-R/DVD-RW Drives	16
QuickFind Diagnostic Panel	16
Rear Panel	21
Power Supply Status LEDs	22
Management Processor LAN LEDs	23
Locator LED and Button	23
Gigabit Ethernet Card LAN LEDs	24

2. External Connectors

Connector Pinouts	27
Universal Serial Bus (USB) Ports	28
VGA Port	28
Serial Ports	29
Management Processor LAN Port	29
Additional Ports on Accessory Boards	30

3. Utilities

Boot Console Handler (BCH)	33
BCH Commands	33
Management Processor (MP)	39
Configuring the MP LAN Port IP Address	40
Accessing the Management Processor	41
Configuring the Management Processor LAN Information	43
MP Command Reference	46

4. Troubleshooting

Information to Collect Before You Contact Support	49
Troubleshooting Methodology	49
Using the Front Panel Power Button	50
Operating System Will Boot	51
Operating System Will Not Boot	51
Troubleshooting Using Online Support Tools	52
Support Tools Manager	52
Event Monitoring Service	52
Management Processor	52
Troubleshooting Using Offline Support Tools	55
Offline Diagnostic Environment (ODE)	55
Troubleshooting Using LED Indicators	56
Front Control Panel LEDs	56
QuickFind Diagnostic Panel LEDs	58

Contents

I/O Baseboard LED Indicators 60
Memory Extender Boards 61

5. Specifications

Introduction 65
Hardware Specifications 65
Server Dimensions and Weights 67
 Component Dimensions 67

Index 69

Figure 1-1. Front View of HP 9000 rp4410 and HP 9000 rp4440 Servers (with Bezel)	12
Figure 1-2. Accessing the Control Panel	12
Figure 1-3. Control Panel.	13
Figure 1-4. Hot-Plug Disk Drive LED Indicators.	15
Figure 1-5. DVD-ROM Drive	16
Figure 1-6. QuickFind Diagnostic Panel	17
Figure 1-7. I/O Baseboard LEDs, Buttons, and Sensors	19
Figure 1-8. Rack Mount and Rackless Rear View	21
Figure 1-9. Power Supply Status LED	22
Figure 1-10. MP LAN LEDs	23
Figure 1-11. Core I/O Single Port LAN LEDs.	24
Figure 1-12. Dual Port LAN Core I/O Card LEDs	25
Figure 2-1. Rear View of HP 9000 rp4410 and HP 9000 rp4440 Servers	27
Figure 2-2. USB Port Connector	28
Figure 2-3. Video Port Connector	28
Figure 2-4. Serial Port Connector	29
Figure 2-5. Management Processor Port.	29
Figure 2-6. LAN Port	30
Figure 2-7. SCSI Port, Ultra 3, 68-Pin	31
Figure 4-1. Front Control Panel LEDs	56
Figure 4-2. QuickFind Diagnostic Label	59
Figure 4-3. I/O Baseboard LEDs, Buttons, and Sensors	60
Figure 4-4. 32 DIMM Memory Extender Board LEDs.	62
Figure 4-5. 16 DIMM Memory Extender Board LEDs.	63

Preface

This preface contains the following sections:

- Intended Audience
- What's New?
- Notational Conventions
- Reader Comments and Feedback
- Related Information
- Printing History

Intended Audience

This document is intended to provide technical product and support information for authorized service providers, customer system administrators, and HP support personnel.

What's New?

- The layout of this document was changed to improve usability.

Notational Conventions

The following notational conventions are used in this publication.

WARNING A warning lists requirements that you must meet to avoid personal injury.

CAUTION A caution provides information required to avoid losing data or avoid losing system functionality.

NOTE A note highlights useful information such as restrictions, recommendations, or important details about HP product features.

- Commands and options are represented using this font.
- **Text that you type exactly as shown** is represented using **this font**.
- *Text to be replaced with text that you supply* is represented using *this font*.

Example:

“Enter the `ls -l filename` command” means you must replace *filename* with your own text.

- **Keyboard keys and graphical interface items (such as buttons, tabs, and menu items)** are represented using **this font**.

Examples:

The **Control** key, the **OK** button, the **General** tab, the **Options** menu.

- **Menu** → **Submenu** represents a menu selection you can perform.

Example:

“Select the **Partition** → **Create Partition** action” means you must select the **Create Partition** menu item from the **Partition** menu.

- Example screen output is represented using this font.

Reader Comments and Feedback

HP welcomes your feedback on this publication. Please address your comments to edit@presskit.rsn.hp.com and note that you will not receive an immediate reply. All comments are appreciated.

Related Information

You can find other information on HP server hardware management, Microsoft® Windows®, and diagnostic support tools in the following publications.

Web Site for HP Technical Documentation:

<http://docs.hp.com>

The main Web site for HP technical documentation is <http://docs.hp.com>, which has complete information available for free.

Server Hardware Information:

<http://docs.hp.com/hpux/hw/>

The <http://docs.hp.com/hpux/hw/> Web site is the systems hardware portion of the docs.hp.com and provides HP nPartition server hardware management details, including site preparation, installation, and more.

Windows Operating System Information

You can find information about administration of the Microsoft® Windows® operating system at the following Web sites, among others:

- http://docs.hp.com/windows_nt/
- <http://www.microsoft.com/technet/>

Diagnostics and Event Monitoring: Hardware Support Tools

Complete information about HP's hardware support tools, including online and offline diagnostics and event monitoring tools, is at the <http://docs.hp.com/hpux/diag/> Web site. This site has manuals, tutorials, FAQs, and other reference material.

Web Site for HP Technical Support:

<http://us-support2.external.hp.com>

HP's IT resource center Web site at <http://us-support2.external.hp.com/> provides comprehensive support information for IT professionals on a wide variety of topics, including software, hardware, and networking.

Books about HP-UX Published by Prentice Hall

The <http://www.hp.com/hpbooks/> Web site lists the HP books that Prentice Hall currently publishes, such as HP-UX books including:

- *HP-UX 11i System Administration Handbook*
http://www.hp.com/hpbooks/prentice/ptr_0130600814.html
- *HP-UX Virtual Partitions*
http://www.hp.com/hpbooks/prentice/ptr_0130352128.html

HP Books are available worldwide through bookstores, online booksellers, and office and computer stores.

Printing History

The Printing History below identifies the edition dates of this manual. Updates are made to this publication on an unscheduled, *as needed*, basis. The updates will consist of a complete replacement manual and pertinent on-line or CD-ROM documentation.

Second Edition	July 2004
Third Edition	April 2005

1 Controls, Ports, and Indicators

Introduction

This chapter describes the controls, ports, and indicators found on the front panel, rear panel, and internal locations of the HP 9000 rp4410 and HP 9000 rp4440 servers.

Front Panel

The front panel of the HP 9000 rp4410 and HP 9000 rp4440 servers provides the controls and indicators commonly used for operation.

Figure 1-1 Front View of HP 9000 rp4410 and HP 9000 rp4440 Servers (with Bezel)

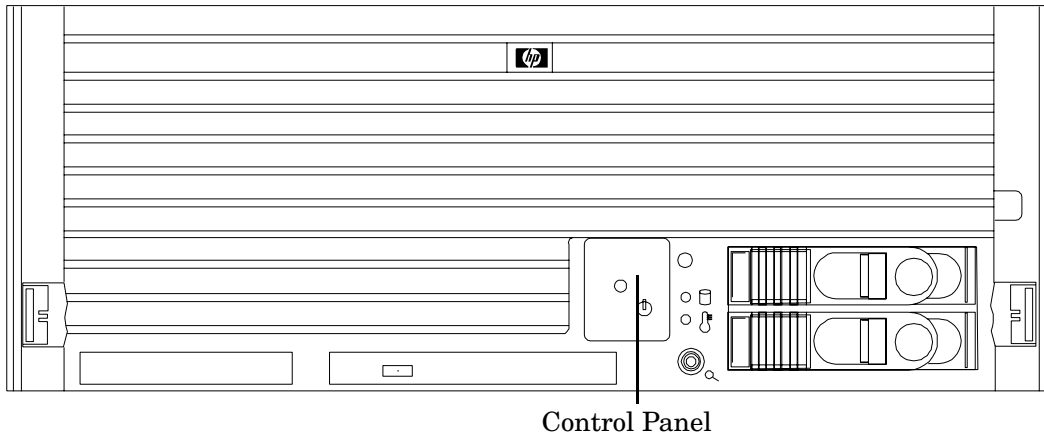

Figure 1-2 Accessing the Control Panel

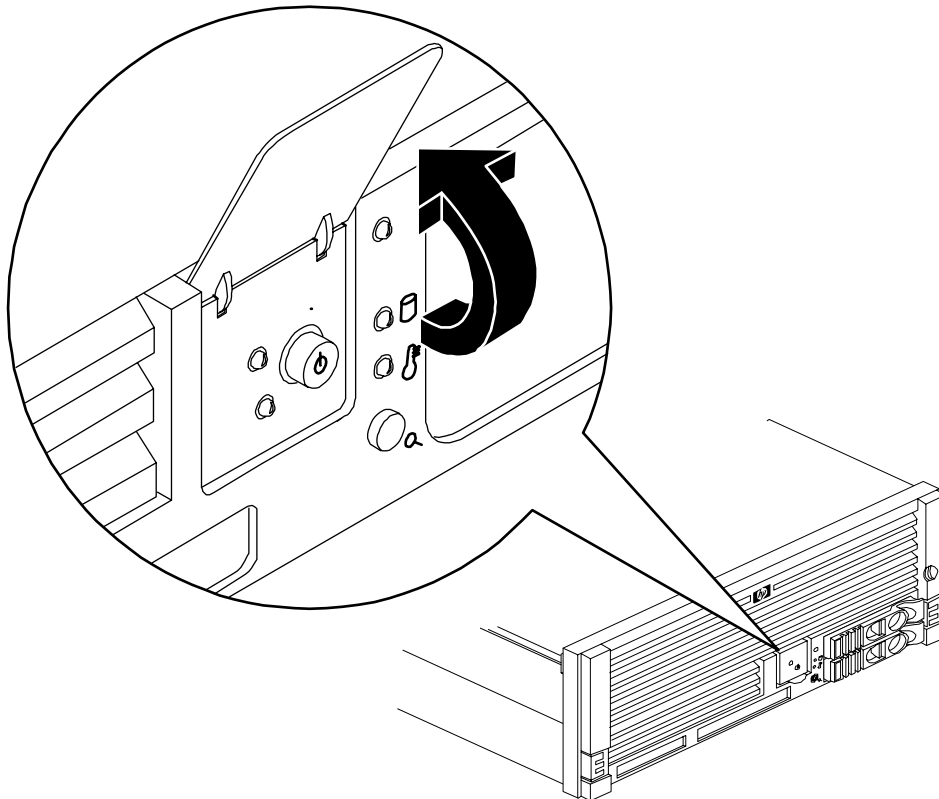

Figure 1-3 Control Panel

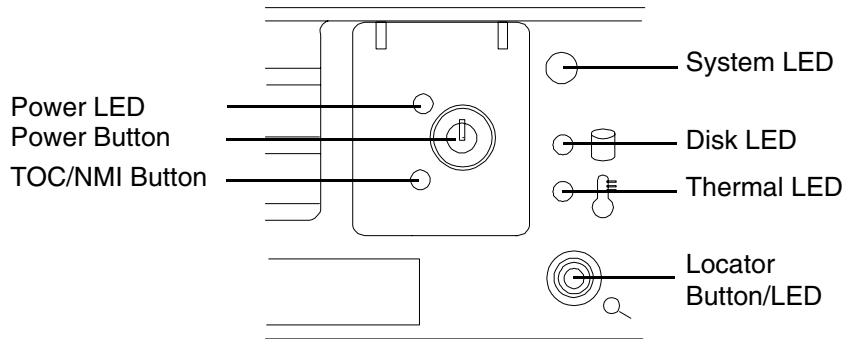

Table 1-1 Control Panel LED Definitions

LED/ Button	State	Flash Rate	Color	Description
System	Running	Steady	Green	Green: System normal—OS up and running
System	Booting	Flashing at 0.5 Hz	Green	Flashing Green: OS booting or at BCH
System	Attention	Flashing at 1 Hz	Yellow	Flashing Yellow: Warning-system needs attention. Redundancy lost, component failure pending
System	Fault	Flashing at 2 Hz	Red	Flashing Red: Hard fault. system halted
System	Off	Off	N/A	Off: System off
Power	On	Steady	Green	Green: Power normal
Power	On	Flashing at 1 Hz	Yellow	Flashing Yellow: Housekeeping voltage present
Power	Off	Off	Off	Off: Power off
Disk LED		Flashing at rate of disk activity	Green	Flashing Green: Disk activity
Thermal LED	OK	Steady	Green	Green: Thermal OK
Thermal LED	Warning	Flashing at 1 Hz	Yellow	Flashing Yellow: Thermal warning
Locator LED/Button		Flashing at 1 Hz	Blue	Flashing Blue: System locator LED may be remotely or locally activated/deactivated

Switch/Button and Front Control Panel LED Definitions

Table 1-2 Switch/Button LED Definitions

Button/Switch	Description
Power button	<p>Controls the power supply (turns system power on/off) if power is available to the power supply. (Controls both power supplies if two are installed)</p> <p>If power is off but power is available to the power supplies, pressing the Power button:</p> <p>Momentarily (less than 1 second) turns on the power supplies and applies power to server circuits</p> <p>For more than 1 second and then released, has no effect</p> <p>If power is on and the system is at ISL, pressing the Power button:</p> <p>Momentarily (less than 1 second) has no effect</p> <p>For more than 1 second, but less than 5 seconds—do not use. This selection initiates e-buzzer functions that are not supported in the HP 9000 rp4410 and HP 9000 rp4440 servers</p> <p>For more than 5 seconds (and then released) causes an immediate/hard power down</p> <p>If power is on and the system is at BCH, pressing the Power button:</p> <p>Momentarily (less than 1 second) causes a immediate/hard power down</p> <p>For more than 1 second, but less than 5 seconds—do not use. This selection initiates e-buzzer functions that are not supported in the HP 9000 rp4410 and HP 9000 rp4440 servers</p> <p>For more than 5 seconds (and then released) causes an immediate/hard power down</p> <p>If power is on but the OS has been shut down, pressing the Power button:</p> <p>Momentarily (less than 1 second) has no effect</p> <p>For more than 1 second, but less than 5 seconds—do not use. This selection initiates e-buzzer functions that are not supported in the HP 9000 rp4410 and HP 9000 rp4440 servers</p> <p>For more than 5 seconds (and then released) causes an immediate/hard power down</p> <p>If the OS is running, pressing the Power button:</p> <p>Momentarily (less than 1 second) has no effect</p> <p>For more than 1 second, but less than 5 seconds—do not use. This selection initiates e-buzzer functions that are not supported in the HP 9000 rp4410 and HP 9000 rp4440 servers</p> <p>For more than 5 seconds (and then released) causes an immediate/hard power down</p>

Table 1-2 Switch/Button LED Definitions (Continued)

Button/Switch	Description
NMI button (Paper clip may be used to depress button)	Press the nonmaskable interrupt (NMI) switch before restarting the system after a hung condition occurs. NMI provides crash dump capture capability. Obtain a system hardware status dump to use in root cause analysis and debugging ^a

a. The same function is available by using the Management Processor command: **CM>TC**.

Additional Controls and Indicators

Storage devices have additional LEDs showing their status.

Hot-Plug Disk Drive Indicators

The hot-plug disk drives have two LEDs per drive, as described below.

- Drive Status LED—The drive status LED is green when power is applied to drive circuits
- Drive Activity LED—The drive activity LED is green and indicates disk drive activity. This LED is controlled by the disk drive directly and turns on when a drive is accessed

Figure 1-4 Hot-Plug Disk Drive LED Indicators

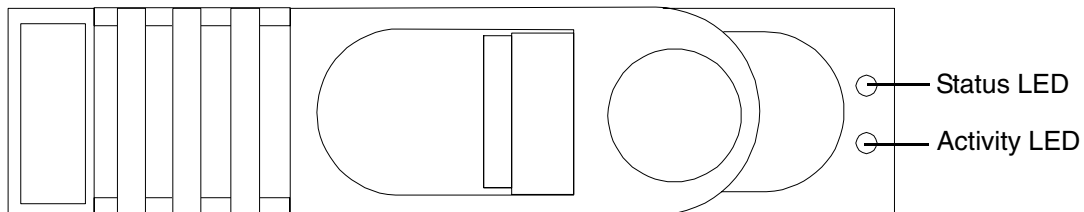

Table 1-3 Hot-Plug Disk Drive LED Definitions

LED	State	Description
Activity LED	Flashing green	Drive is active
Status LED	Green	Drive operating (power applied)

DVD-ROM/DVD-R/DVD-RW Drives

The HP server is delivered with one DVD-ROM drive (DVD-R and DVD-RW drives are optional). Each of these devices has one activity LED.

Figure 1-5 DVD-ROM Drive

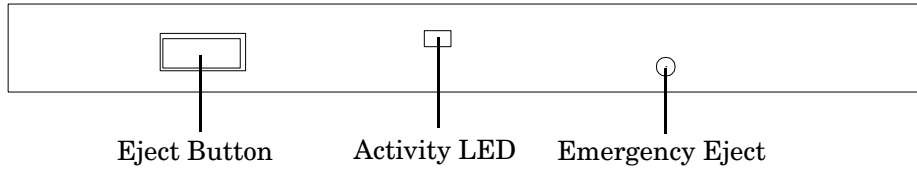

Table 1-4 DVD Drive LED Definitions

LED	State	Description
Activity LED	Flashing green	Drive is active

QuickFind Diagnostic Panel

The QuickFind diagnostic panel has 27 single color LEDs and one multi-color LED for temperature. The LEDs are normally off. The appropriate LED is turned on when an error is detected or a replacement part is required.

Accessing the QuickFind Diagnostic Panel

You can access the QuickFind diagnostic panel by removing the top cover. (Refer to the *HP 9000 rp4410 and HP 9000 rp4440 Server Installation Guide* for cover removal procedure.) You can use the QuickFind diagnostic panel as an aid in troubleshooting.

Figure 1-6 QuickFind Diagnostic Panel

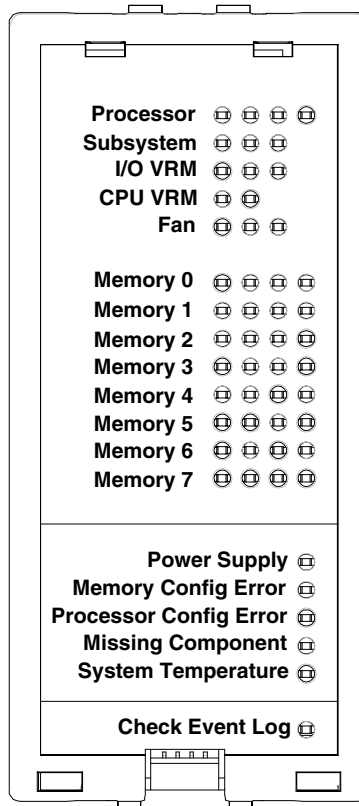

Table 1-5 QuickFind Diagnostic Panel LEDs

Item	LED 0	LED 1	LED 2	LED 3	Details
Processor	Socket 0	Socket 1	Socket 2	Socket 3	<p>If the System LED (on front panel) is in the attention or fault state and the processor LED is lit, then the processor or voltage regulator has failed—the processor module in the specified socket needs to be replaced</p> <p>If the thermal LED is in the warning or critical state and the processor LED is lit, then the processor exceeded the warning or critical level</p>
Subsystem	CPU board	Memory board	I/O board	n/a	A soldered voltage regulator has failed—the specified board must be replaced
I/O VRM	12 volt	5 volt	3 volt	n/a	A plug-in voltage regulator has failed—I/O baseboard must be replaced
CPU VRM	n/a	n/a	n/a	n/a	n/a
Fan module	0	1	2	n/a	<p>One or both fans in a fan module has failed—the module must be replaced</p> <p>Fan 2 is in front of the power supplies</p>
Memory bank X (0-7)	DIMM xA	DIMM xB	DIMM xC	DIMM xD	<p>The specified DIMM has failed—the DIMM must be replaced</p> <p>If all the LEDs for a rank (0-7) are lit and the Memory Config Error LED is lit then the DIMMs in the specified rank are mismatched—replace mismatched DIMM</p>
Check power supply	n/a	n/a	n/a		One of the power supply or power supply fans has failed—replace the power supply. The faulty power supply LED (located on power supply) will be lit
Memory config error	n/a	n/a	n/a		The DIMMs in a rank are mismatched. All the DIMMs in the specified rank (0-7) will be lit
Processor config error	n/a	n/a	n/a		The processors are mismatched—replace mismatched processor
Missing component	n/a	n/a	n/a		A required component(s) is not installed in the system and thus preventing power up
System temp	n/a	n/a	n/a		The internal temperature of the server has exceeded the warning or critical level

Table 1-5 QuickFind Diagnostic Panel LEDs (Continued)

Item	LED 0	LED 1	LED 2	LED 3	Details
Check Event Log	n/a	n/a	n/a		An event has occurred that requires attention

I/O Baseboard LED Indicators

Various LEDs, sensors, reset, and attention buttons are found on the I/O baseboard.

Figure 1-7 I/O Baseboard LEDs, Buttons, and Sensors

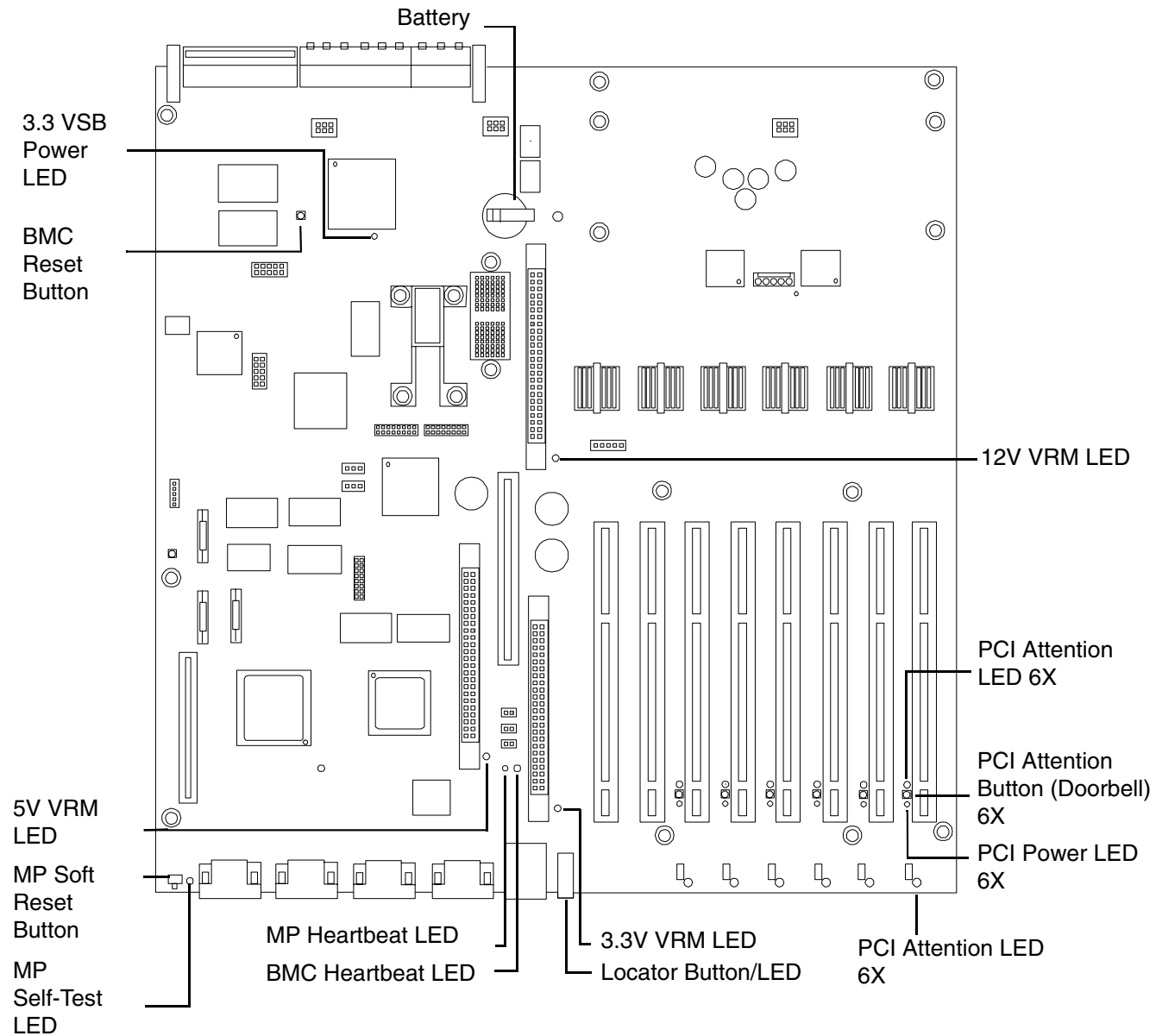

Table 1-6 I/O Baseboard LEDs, Buttons, and Sensors

LED/Button	Color	Status	Condition
12V VRM power LED	Green	On	12V VRM is functioning
5V VRM power LED	Green	On	5V VRM is functioning
3.3V VRM power LED	Green	On	3.3V VRM is functioning
MP heartbeat	Green	Blinking	The management processor is functioning correctly
MP self test LED	Amber	On	The management processor is executing the internal self test
		Off	The management processor has passed the internal self test
BMC heartbeat	Green	Blinking	The baseboard management controller is functioning correctly
3.3 VSB power LED	Green	On	Standby power is available
MP soft reset button	N/A	Press	Resets the management processor values

Rear Panel

The HP server rear panel includes communication ports, I/O ports, AC power connectors, two power supply bays, attention LED indicators for the hot-plug PCI boards, and the locator LED/button. LEDs located on the rear panel of the HP server signal the operational status of:

- Power supplies
- Management processor LAN
- Gigabit Ethernet card LAN
- PCI slots 3-8

Figure 1-8 Rack Mount and Rackless Rear View

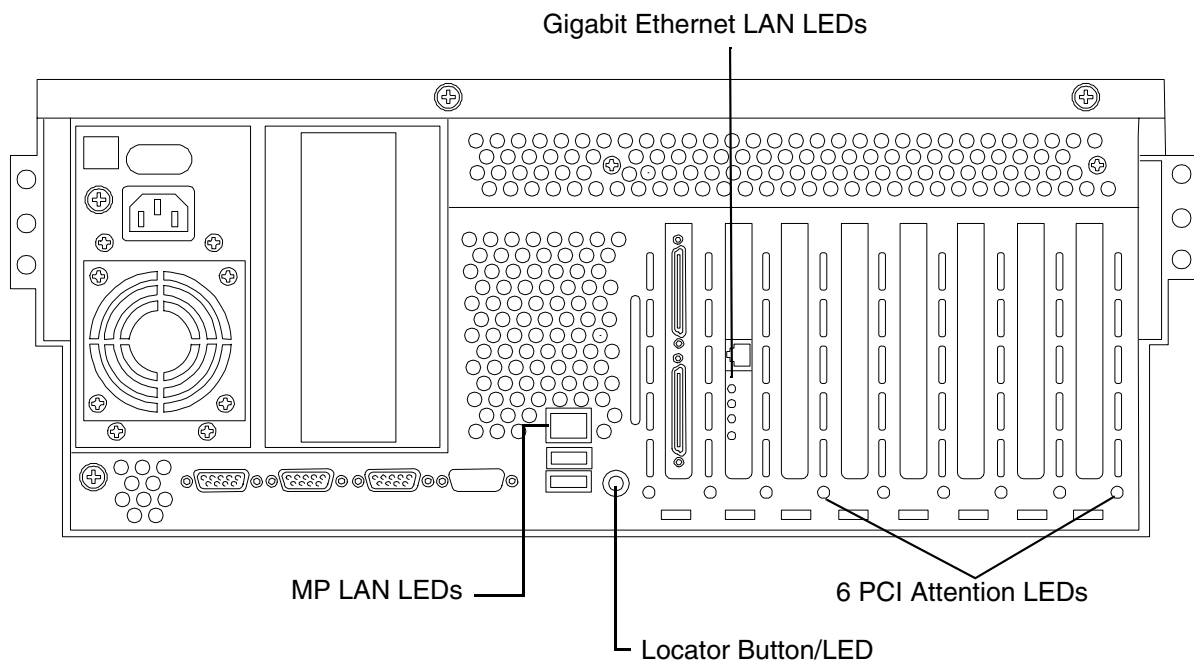

Power Supply Status LEDs

Each power supply unit has three status LEDs located on the power supply rear side. The front control panel power status LED reports a consolidated status of all power supplies.

Figure 1-9 Power Supply Status LED

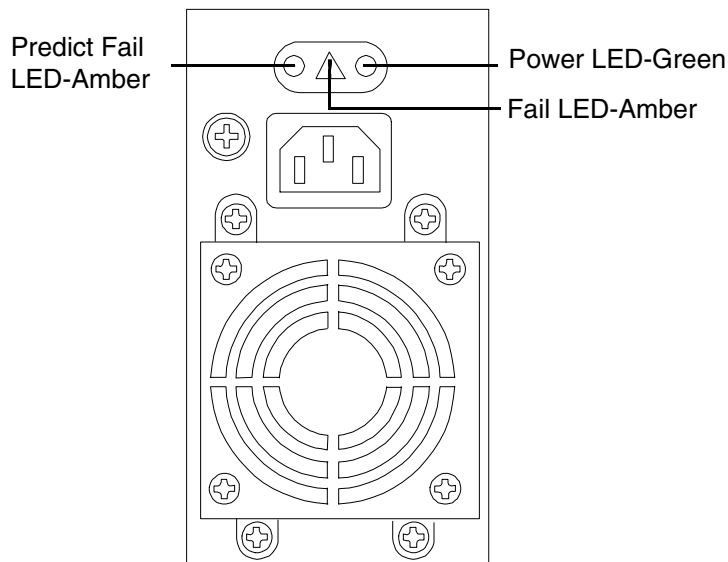

Table 1-7 Power Supply Status LED

Power LED—Green	Predict Fail LED—Amber	Fail LED—Amber	Status
Off	Off	Off	No AC power applied to all PSUs
Off	Off	On	No AC power applied to this PSU only
Blinking	Off	Off	AC present/standby outputs on
On	Off	Off	PSU DC outputs on and OK
Off	Off	On	Power supply failure
On	Blinking	Off	Predictive failure—PSU about to fail because of poorly performing fan
On	Off	Blinking	Current limit on 48 VDC output

Management Processor LAN LEDs

The internal management processor (MP) LAN uses an RJ-45 type connector. This connector has two LEDs (LAN link and LAN activity) that signal status and activity (Figure 1-10).

Figure 1-10 MP LAN LEDs

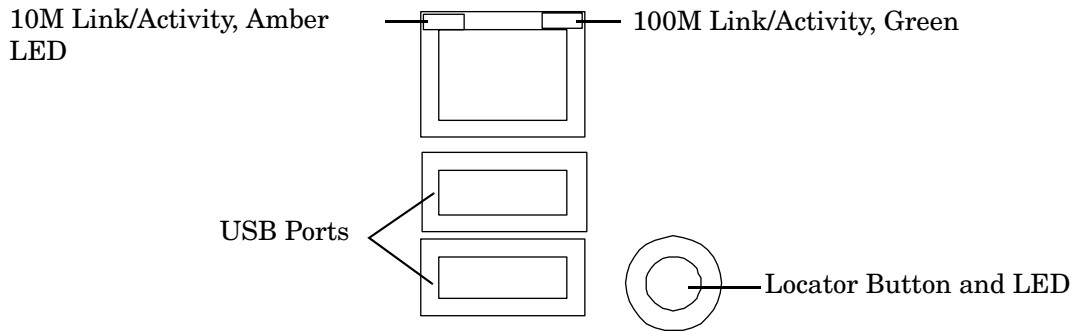

Table 1-8 MP LED Status Descriptions

LED	Condition	Status
10M amber	On	Linked at 10 MBps—no activity
10M amber	Blinking	Linked at 10 MBps—activity present
100M green	On	Linked at 100 MBps—no activity
100M green	Blinking	Linked at 100 MBps—activity present

Locator LED and Button

An LED and button is provided on the rear panel of the server. Another single blue LED and button is on the front control panel. Pressing either button turns both LEDs on or off and enables or disables the locator function. See Figure 1-10, “MP LAN LEDs.”

Gigabit Ethernet Card LAN LEDs

Single Port I/O

The single port I/O Gigabit Ethernet card uses an RJ-45 LAN connector. This connector has four LEDs (three LAN link and one LAN activity) that signal link speed and activity (Figure 1-11).

Figure 1-11 Core I/O Single Port LAN LEDs

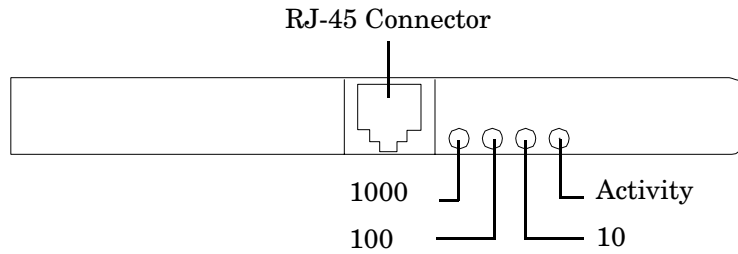

Table 1-9 Core LED Status Descriptions

LED	Condition	Status
Activity	Green—on	Linked—no activity
Activity	Green—off	No link
Activity	Green—blinking	Linked—activity present
1000	Green—on	Link speed—1000 MBps
100	Green—on	Link speed—100 MBps
10	Green—on	Link speed—10 MBps

Figure 1-12 Dual Port LAN Core I/O Card LEDs

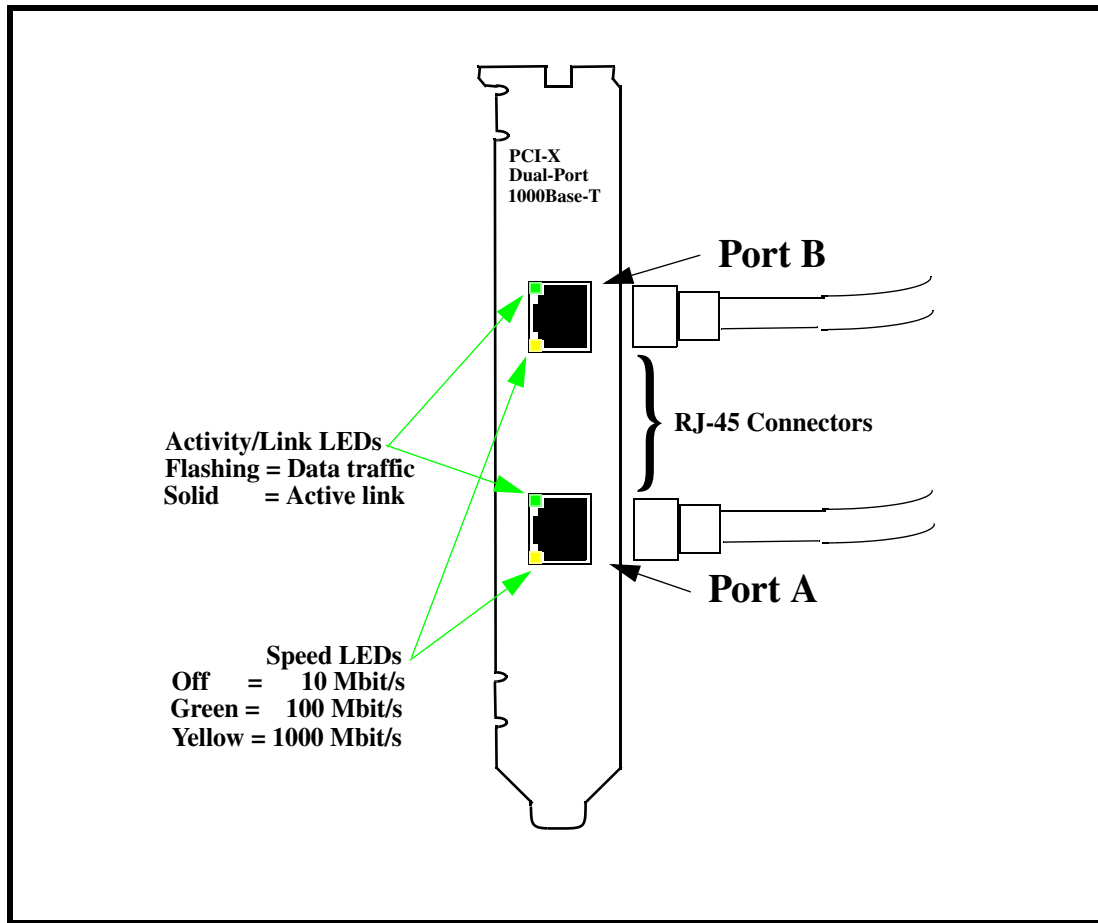

Table 1-10 Dual Port LAN LED Status Descriptions

LED	Condition	Status
Activity	Flashing	Linked—Data Traffic
Activity	Solid	Active link
Speed	Off	Link speed—10 Mbit/s
Speed	Green	Link speed—100 Mbit/s
Speed	Amber	Link speed—1000 Mbit/s

2 External Connectors

Connector Pinouts

The following ports and connectors are found on the rear panel of the HP 9000 rp4410 and HP 9000 rp4440 server (Figure 2-1). The SCSI Host Bus Adapter card in slot 1 and the Gigabit Ethernet card in slot 2 are factory installed.

Figure 2-1 Rear View of HP 9000 rp4410 and HP 9000 rp4440 Servers

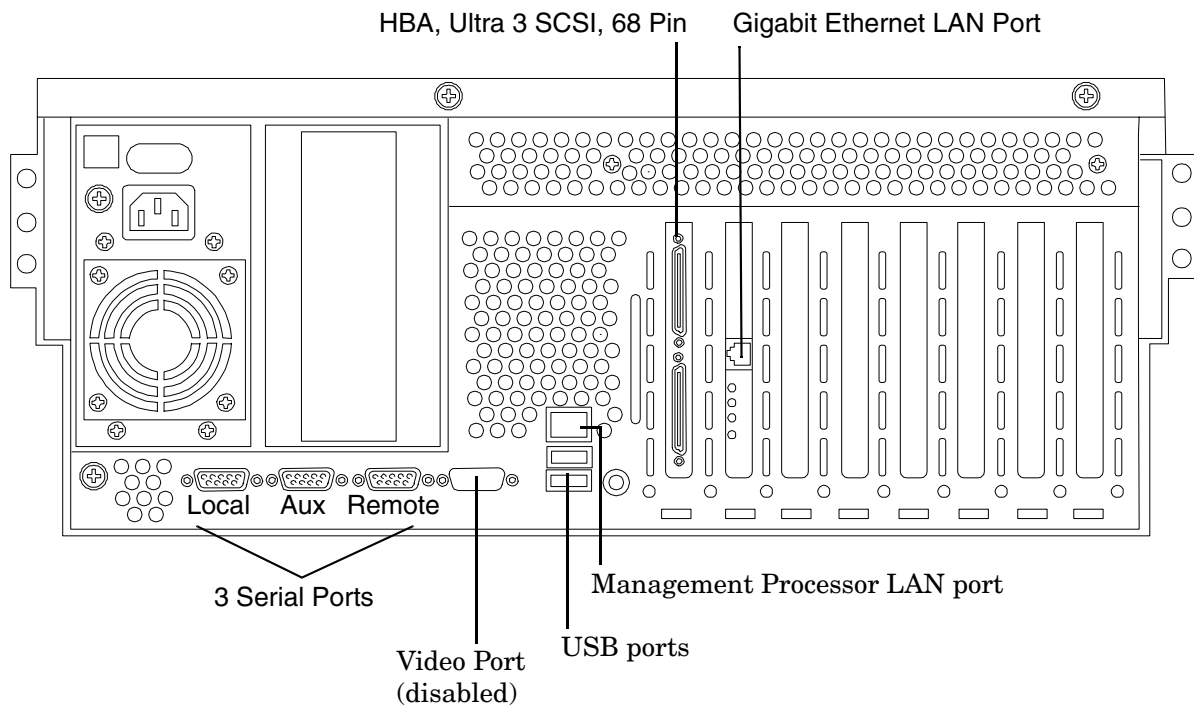

Universal Serial Bus (USB) Ports

Figure 2-2 USB Port Connector

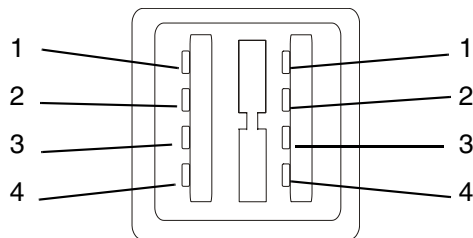

Table 2-1 USB Pinouts

Pin Number	Signal Description
1	+5 VDC
2	MR
3	PR
4	Ground

VGA Port

Figure 2-3 Video Port Connector

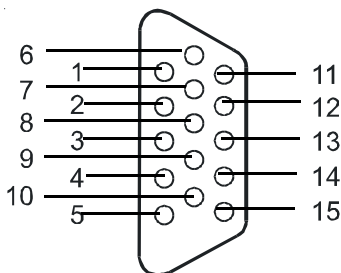

Table 2-2 Video Connector Pinouts

Pin Number	Signal Description	Pin Number	Signal Description
1	Red	9	+5 VDC
2	Green	10	Sync return (ground)
3	Blue	11	Not used
4	Not used	12	Monitor ID bit 1
5	Video self test (ground)	13	Horizontal sync (+)
6	Red return (ground)	14	Vertical sync (-)
7	Green return (ground)	15	Video ID bit 2
8	Blue return (ground)		

Serial Ports

Figure 2-4 Serial Port Connector

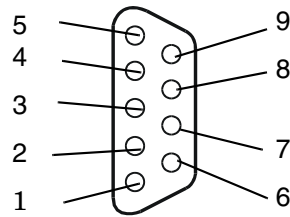

Table 2-3 Serial Port Pinouts

Pin Number	Signal Description
1	Data carrier detect
2	Receive data
3	Transmit data
4	Data term ready
5	Ground
6	Data set ready
7	Request to send
8	Clear to send
9	Ring indicator

Management Processor LAN Port

Figure 2-5 Management Processor Port

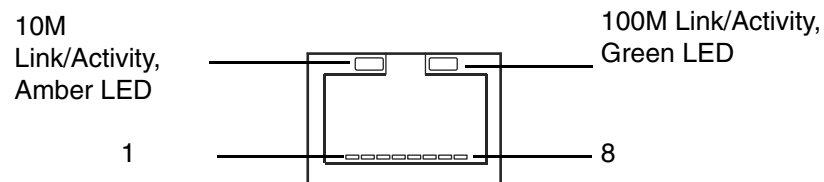

Table 2-4 Management Processor LAN Port Pinouts

Pin Number	Signal Description
1	TXP
2	TXN
3	RXP

Table 2-4 Management Processor LAN Port Pinouts (Continued)

Pin Number	Signal Description
4	Not used
5	Not used
6	RXN
7	Not used
8	Not used

Additional Ports on Accessory Boards

Gigabit Ethernet LAN Port

Figure 2-6 LAN Port

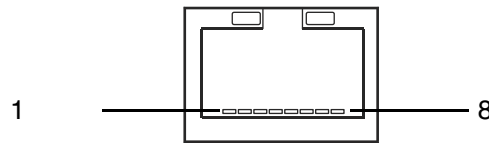

Table 2-5 LAN Port Pinouts

Pin Number	Signal Description
1	RXP
2	RXN
3	TXP
4	Not used
5	Not used
6	TXN
7	Not used
8	Not used

SCSI Port, Ultra 3, 68-Pin

Two Ultra 3, 68-pin SCSI connectors are located on the host bus adapter (HBA) located in PCI slot 1. The upper connector supports SCSI channel A and the lower connector supports SCSI channel B.

Figure 2-7 SCSI Port, Ultra 3, 68-Pin

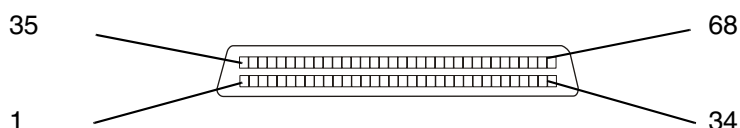

Table 2-6 SCSI Port Pinouts

Pin Number	Signal Description	Pin Number	Signal Description
1	S1 (+DB 12)	35	S35 (-DB 12)
2	S2 (+DB 13)	36	S36 (-DB 13)
3	S3 (+DB 14)	37	S37 (-DB 14)
4	S4 (+DB 15)	38	S38 (-DB 15)
5	S5 (+DB P 1)	39	S39 (-DB P 1)
6	S6 (+DB 0)	40	S40 (-DB 0)
7	S7 (+DB 1)	41	S41 (-DB 1)
8	S8 (+DB 2)	42	S42 (-DB 2)
9	S9 (DB 3)	43	S43 (-DB 3)
10	S10 (+DB 4)	44	S44 (-DB 4)
11	S11 (+DB5)	45	S45 (-DB 5)
12	S12 (+DB 6)	46	S46 (-DB 6)
13	S13 (+DB 7)	47	S47 (-DB 7)
14	S14 (+DB P)	48	S48 (-DB P)
15	S15	49	S49
16	S16 (DIFFSENS)	50	S50
17	S17 (TERMPWR)	51	S51 (TERMPWR)
18	S18 (TERMPWR)	52	S52 (TERMPWR)
19	S19 (RESERVED)	53	S53 (RESERVED)
20	S20	54	S54

Table 2-6 SCSI Port Pinouts (Continued)

Pin Number	Signal Description	Pin Number	Signal Description
21	S21 (+ATN)	55	S55 (-ATN)
22	S22	56	S56
23	S23 (+BSY)	57	S57 (-BSY)
24	S24 (+ACK)	58	S58 (-ACK)
25	S25 (+RST)	59	S59 (-RST)
26	S26 (+MSG)	60	S60 (-MSG)
27	S27 (+SEL)	61	S61 (-SEL)
28	S28 (+C/D)	62	S62 (-C/D)
29	S29 (+REQ)	63	S63 (-REQ)
30	S30 (+I/O)	64	S64 (-I/O)
31	S31 (+DB 8)	65	S65 (-DB 8)
32	S32 (+DB 9)	66	S66 (-DB 9)
33	S33 (DB 10)	67	S67 (-DB 10)
34	S34 (DB 11)	68	S68 (-DB 11)

3 Utilities

Boot Console Handler (BCH)

The boot console handler (BCH) is separate code in processor dependent code (PDC). It has two purposes:

- It lets the bootstrap code know which path to boot from
- It allows you to interact with PDC to view and modify a set of specific system parameters

Booting is accomplished in the standard PA RISC manner, but might be transparent depending on the state of the autoflags (boot, search, and start). If the autoflags are clear and you override autobooting, a boot sequence will end in the interactive portion of BCH where modification and viewing of some system parameters is possible.

NOTE When the autostart flag is off, autoboots are interrupted if a configuration change occurs, which causes reduced performance. Therefore, you must intervene prior to booting to the internal system loader (ISL).

The auto boot will halt at the BCH prompt and you may continue booting by entering `boot.`

BCH Commands

In the interactive portion of BCH there is a Main Menu and five submenus.

Table 3-1 BCH Commands

Submenu	Description
B0ot [PRI ALT <path>]	Boot from a specified path
DIisplay	Redisplay the current menu
HElp [<menu> <command.>]	Display help for specified command or menu
RESET	Restart the system
MAin	Return to the Main Menu

Table 3-2 Boot Paths

Boot Source	Boot Path
Bottom Disk – Slot 1 (SCSI ID = 0)	0/1/1/0.0.0 (Simplex Mode) 0/1/1/1.0.0 (Duplex Mode)
Top Disk – Slot 2 (SCSI ID = 1)	0/1/1/0.1.0 (Duplex Mode)
DVD	0/0/3/0.0

Boot Console Handler (BCH)**Main Menu**

The following commands are available in the Main Menu:

```

----- Main Menu -----

```

Command	Description
-----	-----
BOot [PRI ALT <path>]	Boot from specified path
** Path [PRI ALT CON KEY] [<path>]	Display or modify a path
SEArch [DIsplay IPL] [<path>]	Search for boot devices
COntfiguration menu	Displays or sets boot values
INformation menu	Displays hardware information
SERvice menu	Displays service commands
* DeBug menu	Displays debug commands
MFG menu	Displays manufacturing commands
DIsplay	Redisplay the current menu
HElp [<menu> <command>]	Display help for menu or command
RESET	Restart the system

```

-----
Main Menu: Enter command or menu >

```

* Not accessible to user.

** You cannot modify the keyboard path.

Configuration Menu

The following commands are available in the configuration menu:

Main Menu: Enter command or menu > co

---- Configuration Menu -----

Command	Description
AUto [BOot SEARch STart] [ON OFF]	Display or set specified flag
BootID [<proc>] [<bootid>]	Display or set Boot Identifier
BootINfo	Display boot-related information
BootTimer [0 - 200]	Seconds allowed for boot attempt
CPUconfig [<proc>] [ON OFF]	Config/Deconfig processor
Default	Set the system to predefined values
FAn [HI NORmal]	Display or change fan speed
FastBoot [ON OFF]	Display or set boot tests execution
PAth [PRI ALT] [<path>]	Display or modify a path
SEARch [DISplay IPL] [<path>]	Search for boot devices
TIme [c:y:m:d:h:m:[s]]	Read or set the real time clock in GMT
BOot [PRI ALT <path>]	Boot from specified path
DISplay	Redisplay the current menu
HElp [<command>]	Display help for specified command
RESET	Restart the system
MAin	Return to Main Menu

Configuration Menu: Enter command >

The configuration default command sets the following values:

Primary boot path: 0/0/1/0.0
 Alternate boot path: 0/0/2/0
 Console path: 0/0/1/0.0
 Keyboard path: 0/0/4/0.0

Boot Console Handler (BCH)

```

Autoboot:          ON
Autosearch:       ON
Autostart:        OFF
BootTimer         0
    
```

Information Menu

The following commands are available from the information menu:

Main Menu: Enter command or menu > in

```

---- Information Menu -----

```

Command	Description
-----	-----
ALL	Display all system information
BootINfo	Display boot-related information
CAche	Display cache information
ChipRevisions	Display revisions of major VLSI
COprocessor	Display coprocessor information
FRU	Display FRU information
FwrVersion	Display firmware version
* IO	Display I/O interface information
LanAddress	Display Core LAN station address
MEemory	Display memory information
** PRocessor	Display processor information
*** Warnings	Display selftest warning messages
BOot [PRI ALT <path>]	Boot from specified path
DIisplay	Redisplay the current menu
HElp [<command>]	Display help for specified command
RESET	Restart the system
MAin	Return to Main Menu

```

----
    
```

Information Menu: Enter command >

* The PCI device information displayed here includes description, path, vendorID, deviceID, slot number, and bus number.

** The PRocessor command displays system model string.

***Warnings displayed are:

- WARNING: Too many cpus for a rp4410 system. System will not boot
- WARNING: A fatal error has occurred-system cannot boot. Review warning messages in the information menu

Service Menu

The following commands are available from the service menu:

Main Menu: Enter command or menu > ser

---- Service Menu -----

Command	Description
-----	-----
CLEARPIM	Clear (zero) the contents of PIM
SCSI [option] [<path>] [<val>]	Display or set SCSI controller values
MemRead <address> [<len>]	Read memory and I/O locations
PDT [CLEAR]	Display or clear the PDT
PIM [<proc>] [HPMC LPMC TOC]	Display PIM information
ProductNum <O C> [<number>]	Display or set Product Number
ScRoll [ON OFF]	Display or change scrolling ability
SELftests [ON OFF]	Enable/disable self test execution
BOot [PRI ALT <path>]	Boot from specified path
DIisplay	Redisplay the current menu
HElp [<command>]	Display help for specified command
RESET	Restart the system
MAin	Return to Main Menu

Service Menu: Enter command >

Boot Console Handler (BCH)

The `ProductNum` command is used to configure the original or current product number. The software ID (SWID) does not get updated automatically when the original product number changes, but you can manually update the SWID by executing the default command from the Configuration SubMenu.

Use the `SCSI` command to display and set the SCSI controller parameters, such as initiator ID and speed. The OS device drivers use these parameters to program the controller. Note that these values are only suggested by the device driver; the actual values programmed into the controller might be different.

Management Processor (MP)

Integrated Lights-Out (iLO) offers remote server management through an independent management processor (MP). It provides a way for you to connect to a server and perform administration or monitoring tasks for the server hardware. iLO is available whenever the system is connected to a power source, even if the server main power switch is in the off position.

iLO controls power, reset, and Transfer of Control (TOC) capabilities; provides console access; displays and records system events; and can display detailed information about the various internal subsystems. iLO also provides a virtual front panel that you can use to monitor system status and see the state of front panel LEDs. All iLO functions are available through the server LAN and the local RS-232 and remote RS-232 ports. Access to local and remote ports, telnet, and secure shell (SSH) is through the iLO text interface, while Web access is through a graphical user interface (GUI).

iLO was introduced into most Integrity Entry Class servers in late 2004. Prior to that, embedded remote server management was referred to as MP functionality. All legacy MP functionality has been carried forward and combined with new features, all under the heading of "iLO". Therefore, "iLO" and "MP" mean the same thing for Entry Class servers.

Once you update the firmware to version E.03.13, the following features in the Integrated Lights-Out MP are activated:

- Always-on capability: iLO is active as long as the power cord is plugged in
- Multiple access methods: Local, remote, telnet, and SSH use the iLO text interface. Web access uses a GUI.
 - Local Serial Port: Use a terminal or laptop computer for direct connection.
 - Remote/Modem Serial Port: Use a dedicated modem RS-232 port and external modem.
 - LAN: Use telnet, Web, or SSH to access iLO LAN.
- Remote power cycle; power on or power off; reset
- Mirrored console: The system console output stream is reflected to all connected console users, and any user can provide input.
- Independent, non mirrored sessions (from local and modem ports)
 - Direct session with OS using the MP command `SE`
 - Connection to another iLO using the MP command `CSP`
- Display of information about various internal subsystems
 - Field replaceable unit (FRU) information
 - System power state, temperature information, and fan status
 - Status of processors
- Logging, display, and keyword search of:
 - System console history
 - System events
- User access control
- DHCP and DNS support

- IPMI over LAN
- Licensing
- iLO Advanced Pack features, such as SSH access, group actions capability, and LDAP

NOTE A complete description of the MP is provided in the *HP Integrity and HP 9000 Integrated Lights-Out Management Processor Operations Guide*.

Configuring the MP LAN Port IP Address

By connecting the MP LAN port to an active network, you have two options for configuring an IP address. The first option is to use a DHCP server, which automatically assigns an IP address, and the other is to use the ping command from another host on the same subnet to set a static IP address for the MP. After the IP address has been set, you can establish a telnet session to configure additional parameters.

If you are using a DHCP server, and it provides the Domain Name, and if the primary DNS server accepts dynamic DNS (DDNS) updates or has been configured through the DHCP server, then you can use a default host name to connect to the MP through telnet. The default host name is 14 characters long, consisting of the letters “mp” followed by the 12 characters of the Media Access Protocol (MAC). See “Configure an IP Address” on page 41 to determine the MAC address. If no DNS access is available, the telnet session can use the assigned IP address.

If you are using DHCP, proceed to “Accessing the Management Processor” on page 41. For more information on configuring DHCP, see “Configuring the Management Processor LAN Information” on page 43. For a non-DHCP implementation, perform the following steps to configure a static IP address.

Configuring a Static IP Address (Non-DHCP)

To configure a static IP address for the MP LAN port, follow these steps:

1. Set up local terminal access.
2. Configure the IP address.

Set Up Local Terminal Access After powering on the terminal, ensure the communications settings are as follows:

- 8/none (parity)
- 9600 baud
- None (receive)
- None (transmit)

If the terminal is a PC using Reflection 1, check or change these communications settings by performing the following steps:

Step 1. From the Reflection 1 Main screen, pull down the Connection menu and choose **Connection Setup**.

Step 2. Choose **Serial Port**.

Step 3. Choose **Com1**.

Step 4. Check the settings and change, if required.

Go to More Settings to set Xon/Xoff. Click **OK** to close the More Settings window.

Step 5. Click **OK** to close the Connection Setup window.

Step 6. Pull down the Setup menu and choose **Terminal** (under the Emulation tab).

Step 7. Choose a supported terminal type.

The preferred type is VT100.

Step 8. Click **Apply**.

This option is not highlighted if the terminal type you want is already selected.

Step 9. Click **OK**.

Configure an IP Address To configure the MP LAN static IP address, perform the following steps:

Step 1. Determine the Media Access Control (MAC) address of the MP LAN interface by viewing the label located at the rear of the server.

Step 2. Connect a LAN cable on your local subnet to the core I/O LAN port.

Step 3. Add an Address Resolution Protocol (ARP) table entry to another host located on your local subnet. This ARP table entry maps the MAC address of the core I/O LAN interface to the IP address chosen for that interface.

NOTE Adding an entry to the ARP table is typically done using the ARP command with the appropriate option. For example, **arp -s** is used with Windows. Consult your operating system documentation for more information.

Step 4. Use the **ping** command from the host that has the new ARP table entry. The destination address is the IP address that is mapped to the MAC address of the MP. The MP LAN port should now be configured with the appropriate IP address.

Step 5. Use the **telnet** command to connect to the MP from a host on the local subnet.

Accessing the Management Processor

You can connect to the management processor using the following methods:

- The local serial port using a local terminal
- The remote Customer Service Modem (CSM) port using external modem (dial-up) access, if remote modem access is configured
- The MP LAN port using the Web interface, telnet, or SSH, if login access through the MP LAN is enabled

Local Terminal Access to the Management Processor

You establish communication with the MP by connecting a terminal to the local CSM I/O serial port.

You can establish a terminal session using a standalone terminal or using terminal emulation software, such as HyperTerm, Putty, or Reflection 1 running on a PC.

During installation, communicating with the MP enables such tasks as:

- Verifying that the components are present and installed correctly
- Configuring the LAN port

Interacting with the Management Processor

To interact with the MP command line interface, perform the following steps:

NOTE On initial system installation, the MP has two default user accounts:

- All Rights (Administrator) level user; login = Admin, password = Admin (both are case sensitive).
- Console Rights (Operator) level user; login = Oper, password = Oper (both are case sensitive).

For security reasons, HP recommends that you use the UC command during the initial logon session to modify default passwords (enter **CM** at the MP> prompt, and enter **UC** at the MP:CM> prompt).

IMPORTANT Deleting default users such as Admin prevents you from using the HP Systems Insight Manager group actions feature.

Step 1. Log in using your MP user account name and password.

NOTE If you are logged in, the MP Main Menu displays. To follow this procedure, make sure you are at the MP Main Menu. Use **Ctrl-B** to return to the MP Main Menu.

Step 2. Use the MP menus and commands as needed. Main Menu commands are shown in “MP Main Menu”. You can access commands not displayed in the MP Main Menu in command mode by first using the CM command at the MP prompt. You can display a list of available commands using the MP help function. Invoke the help function from either the MP Main Menu or the Command Menu prompts by entering **HE** followed by **LI**. You can return to the MP Main Menu by pressing **Ctrl-B**.

Step 3. Log out using the X command (enter **X** at the MP> prompt) after returning to the MP Main Menu.

MP Main Menu

Following are the MP Main Menu commands:

```
MP MAIN MENU:
CO: Console
VFP: Virtual Front Panel
CM: Command Menu
CL: Console Logs
SL: Show Event Logs
CSP: Connect to Service Processor
SE: Create OS Session
HE: Main Menu Help
X: Exit Connection
```

NOTE The previous example shows the Main Menu screen accessed through the local serial or remote modem ports. The list of commands displayed might be different and depends on your method of access to the MP.

Configuring the Management Processor LAN Information

LAN information includes the management processor network name, IP address information, and configuring DHCP and DNS service information.

To configure the management processor LAN IP address:

Step 1. At the MP Main Menu prompt (MP>), enter **CM** to choose command mode.

Step 2. At the command mode prompt (MP:CM>), enter **LC** (for LAN configuration).

The screen displays the default values and asks if you want to modify them. It is good practice to write down the information, because you might need it for future troubleshooting. See “The LC Command Screen” on page 44.

NOTE The default value in the “IP address” field is set at the factory. You must configure the actual MP LAN IP address.

Step 3. The screen displays the current LC data. When prompted to enter a parameter name, **A** to modify All, or **Q** to Quit, enter **A** to choose all parameters.

Step 4. The screen displays the current DHCP status. If DHCP is used to acquire IP address information, enter **E** to enable, **D** to disable, or **Q** unless you are using the local serial port.

To disable DHCP from the local serial port:

- a. Use the **LC** command to disable DHCP.
- b. Commit the DHCP change.
- c. Use the **LC** command again to set network parameters.

CAUTION Modifying the DHCP, IP address, gateway IP address, or subnet mask parameters will drop all present LAN and Web connections.

NOTE Changing DHCP status to Enabled or Disabled resets IP address, gateway IP address, and subnet mask parameters to factory default values.

NOTE If the IP address, gateway IP address, and subnet mask are obtained through DHCP, you cannot change them without first disabling DHCP.

Step 5. The screen displays the current IP address. When prompted to enter a new value or **Q**, enter the new IP address.

Step 6. The screen displays the current host name. When prompted to enter a new value or **Q**, enter the new MP network name.

This is the host name for the MP LAN displayed at the command prompt. It is also used to identify the MP LAN interface in a DNS database. The name can be up to 64 characters in length, and must start with a letter, end with a letter or number, and contain only letters, numbers, or dashes.

NOTE The host name is not case sensitive.

- Step 7.** The screen displays the current subnet mask name. When prompted to enter a new value or **Q**, enter the new subnet mask name.
- Step 8.** The screen displays the current gateway address. When prompted to enter a new value or **Q**, enter the new gateway address.
- Step 9.** The screen displays the current link state information. When prompted to enter a new value or **Q**, press **enter**. The message -> Current Link State has been retained displays.
- Step 10.** The screen displays the current Web console port number. When prompted to enter a new value or **Q**, press **enter**. The message -> Current Web Console Port Number has been retained displays.
- Step 11.** The screen displays the current SSH console port number. When prompted to enter a new value or **Q**, press **enter**. The message -> Current SSH Console Port Number has been retained displays.

NOTE SSH settings will not display if you do not have Integrated Lights-Out Advanced Pack licensing.

- Step 12.** The screen displays a new LC listing, including the values entered in the preceding steps. Verify that the desired values have been accepted. When prompted to enter a parameter for revision, **Y** to confirm, or **Q** to Quit, enter **Y** to confirm all parameters.

```
> LAN Configuration has been updated
-> Reset MP (XD command option 'R') for configuration to take effect.
MP Host Name: mpserver
```

- Step 13.** Enter **XD -reset** to reset the MP.
- Step 14.** After the MP resets, log in to the MP again. Then enter the MP command mode (enter **CM** at the MP: prompt).
- Step 15.** At the MP:CM> prompt, enter **LS** to confirm the new LAN settings.
- Step 16.** Enter **SA** to enable or disable Web console and telnet access after the MP has been reset.

The LC Command Screen

The following screen shows LC command output:

```
MP:CM> LC -nc
Current LAN Configuration:
  MAC Address       : 0x0060b0f54c51
  DHCP Status      : Enabled
  IP Address        : 127.1.1.1
  MP Host Name     : maestro
  Subnet Mask       : 255.255.248.0
  Gateway Address   : 127.1.1.1
  Link State        : Auto Negotiate
```

Web Console Port Number : 2023

SSH Access Port Number : 22

IPMI/LAN Port Number : 626

LAN status: UP and RUNNING

-> Command successful.

MP:CM>

NOTE The SSH console port number does not display if you do not have Integrated Lights-Out Advanced Pack licensing.

MP Command Reference

There are two menus from which commands are executed: the MP Main Menu and the Command Menu. You access the Command Menu by first using the CM command at the MP> prompt.

The following tables provide a reference for commands available through the command line interface.

MP Main Menu Commands

Commands are listed in Table 3-3.

Table 3-3 MP Main Menu Commands and Descriptions

Command	Description
CL	View console log
CM	Enter command mode
CO	Select console mode
CSP	Connect to another service processor
HE	Display help for menu or command
SE	Enter OS session
SL	Show event logs
VFP	Display virtual front panel
X	Exit

Command Menu Commands

Commands are listed in Table 3-4.

Table 3-4 Command Menu Commands and Descriptions

Command	Description
BP	Reset BMC passwords
CA	Configure async or serial ports
DATE	Display the current date
DC	Default configuration
DF	Display field replaceable unit (FRU) information
DI	Disconnect remote or LAN console
DNS	Set DNS configuration
FW	Upgrade MP firmware
HE	Display help for menu or command
ID	Display or modify system information

Table 3-4 Command Menu Commands and Descriptions (Continued)

Command	Description
IT	Modify MP inactivity timers
LC	LAN configuration
LDAP	LDAP configuration
LM	License management
LOC	Display and configure locator LED
LS	LAN status
MR	Modem reset
MS	Modem status
PC	Remote power control
PG	Paging parameter setup
PR	Power restore
PS	Power management module status
RB	Reset BMC
RS	Reset system through RST signal
SA	Set access options
SO	Configure security options
SS	Display system processor status
SYSREV	Display all firmware revisions
TC	Reset via transfer of control (TOC)
TE	Tell (send a message to other users)
UC	User configuration
VDP	Display virtual diagnostic panel LEDs
WHO	Display connected management processor users
XD	Diagnostics or reset of management processor

4 Troubleshooting

Information to Collect Before You Contact Support

Before you contact HP support, you should:

Step 1. Check information on troubleshooting and attempt to solve the problem.

- Note failure symptoms and error indications (LEDs and messages) by checking the SEL and FPL logs
- Try to determine precisely what did or did not happen

Step 2. Collect the following information:

- The model number of your server (for example, rp4440 server)
- The product number of your server. This can be found on the identification label, which is found at the front of the unit (typically A6961)
- The serial number of your server. This can be found on the identification label

Step 3. Become familiar with your system configuration:

- Are you using the LAN, RS232, or web interface to monitor the server?
- How many processors, DIMMs, and PCI cards have been installed?
- What versions of processor, memory, and PCI cards are used and where are they installed?
- What accessories are installed?

Step 4. Determine the following:

- Which firmware versions are in use?
- When did the problem start?
- Have recent changes been made to the system?
- Which operating system and version is in use?

Troubleshooting Methodology

WARNING Ensure that the system is powered down and all power sources have been disconnected from the server prior to working within the server.

Voltages are present at various locations within the server whenever an AC power source is connected. This voltage is present even when the main power switch is in the off position.

Failure to observe this warning could result in personal injury or damage to equipment.

CAUTION Do not operate the HP server for more than 10 minutes with any cover (including power supplies and disk drives) removed. If you are hot-swapping a fan, reinstall the cover within 10 minutes to prevent overheating. Otherwise, damage to system components may result due to improper cooling airflow.

To troubleshoot your server with online diagnostic tools, you must be familiar with the HP-UX operating system. You should also be familiar with the Offline Diagnostics Environment (ODE). Install both online and offline troubleshooting programs on your system before trouble is suspected. Descriptions and user information about offline troubleshooting tools are available at <http://docs.hp.com>.

Use the online diagnostic tools if you can boot your system. Online troubleshooting programs are available on the HP-UX operating system CD.

If you can not boot your system, run offline troubleshooting tool from the ODE CD that ships with your server. ODE CDs are platform-specific for Integrity and PA-RISC servers.

Other information that can aid in troubleshooting is contained elsewhere in this document. See Chapter 1, “Controls, Ports, and Indicators,” for further information about deciphering all other LEDs in your system.

Using the Front Panel Power Button

The server power button on the front panel operates differently, depending on how long the button is held in and on what the system is doing when the button is pressed. You must be aware of its uses to properly troubleshoot the system. Power button functions are described in the following table.

Table 4-1 Power Button Functions

System State	Switch Pressed Time	Result
Power connected to power supplies—system power off	1 second or less	System power on
	More than 1 second	No effect
System at ISL	Less than 1 second	Hard shutdown
	More than 1 second but less than 5 seconds	Not used. This selection initiates E-buzzer functions that are not supported in the HP 9000 rp4410 and HP 9000 rp4440 servers
	More than 5 seconds	Hard shutdown
System at BCH	Less than 1 second	Hard shutdown
	More than 1 second but less than 5 seconds	Not used. This selection initiates E-buzzer functions that are not supported in the HP 9000 rp4410 and HP 9000 rp4440 servers
	More than 5 seconds	Hard shutdown

Table 4-1 Power Button Functions (Continued)

System State	Switch Pressed Time	Result
Power on—OS shut down	Less than 1 second	No effect
	More than 1 second but less than 5 seconds	Not used. This selection initiates E-buzzer functions that are not supported in the HP 9000 rp4410 and HP 9000 rp4440 servers
	More than 5 seconds	Hard shutdown
OS running	Less than 1 second	No effect
	More than 1 second but less than 5 seconds	Not used. This selection initiates E-buzzer functions that are not supported in the HP 9000 rp4410 and HP 9000 rp4440 servers
	More than 5 seconds	Hard shutdown

Operating System Will Boot

If your operating system is running and you are experiencing problems, use the following online tools to help solve your problem: see “Troubleshooting Using Online Support Tools” on page 52.

- Support Tools Manager (STM)
- Event Monitoring Service (EMS)
- Management Processor (MP)

Operating System Will Not Boot

If your operating system will not boot, but you are able to reach the BCH (from either the main disk partition or CD), then use the following offline tools to help solve your problem: see “Troubleshooting Using Offline Support Tools” on page 55.

- Offline Diagnostic Environment (ODE)
- Management Processor (MP)

Troubleshooting Using Online Support Tools

The following sections describe online support tools that are available in the HP-UX environment.

Support Tools Manager

Support Tools Manager (STM) is available in three user interfaces:

- Graphical interface for X-based terminals (XSTM)
- Menu interface for ASCII terminals (MSTM)
- Command line interface for all ASCII terminals (CSTM)

You can use the graphical and menu interfaces intuitively and you can use the command line interface to drive STM using scripts.

You can use diagnostics to thoroughly test a device and isolate failures down to the suspected Field Replaceable Unit (FRU).

For complete documentation on how to access and use STM, go to <http://docs.hp.com>. Under Topics menu, go to Diagnostics and look for Support Tools Manager.

Event Monitoring Service

Event Monitoring Service (EMS) is the framework for monitoring hardware and reporting events. You can use EMS to eliminate most undetected hardware failures that cause data loss or interruptions of system operation. You can monitor a hardware device (such as a disk) for the occurrence of any unusual activity (called an event). When an event occurs, it is reported by a variety of notification methods such as e-mail. Event detections are handled automatically with minimal involvement on your part.

The following monitors are available:

- CMC monitor
- UPS monitor
- FC hub monitor
- FC switch monitor
- Peripheral status monitor
- Memory monitor

EMS comes with your HP-UX operating system. To bring up the event monitoring Main Menu, execute the following command at the shell prompt:

```
/etc/opt/resmon/sbin/monconfig
```

From the list of Main Menu selections, choose:

```
(E) Enable Monitoring
```

Management Processor

The management processor (MP) interface provides diagnostic and configuration capabilities. By viewing the system logs you can identify and solve problems affecting your computer. To access your MP interface and system logs, perform the following steps:

NOTE The MP interface must be accessed from a terminal console that is attached to the MP through the MP LAN or MP remote serial connector. The MP is always available for troubleshooting, regardless of the state of your system, as long as there is AC power applied to your computer.

NOTE A description of the MP is provided in the *HP Integrity and HP 9000 Integrated Lights Out Operations Guide*.

- Step 1.** If necessary, press **Ctrl+B** to access the MP interface.
- Step 2.** Log in with proper user name and password.
- Step 3.** Enter **c1** to display the console logs. This log displays console history from oldest to newest.
- Step 4.** Enter **s1** to display the system logs. The system logs consist of:
 - System event
 - Forward progress
 - Current boot
 - Previous boot
 - Live events
 - Clear SEL/FPL logs
- Step 5.** For a complete explanation of the management processor and all commands see Chapter 3, "Utilities."

System Event Logs (SEL)

To access the system event logs perform the following steps:

- Step 1.** Access the optional management processor command prompt.
- Step 2.** Run the **s1** command. The Event Log Viewer menu will display:

```
SL

Event Log Viewer Menu:

  Log Name                Entries    % Full    Latest Timestamped Entry
-----
  E - System Event        39         3 %      01 Nov 2004 17:15:03
  F - Forward Progress   1307       32 %
  B - Current Boot       299        99 %
  P - Previous Boot      0
  C - Clear All Logs
  L - Live Events

Enter menu item or [Ctrl-B] to Quit:
```

- Step 3.** Select **e** to review the events. The Event Log Navigation menu will display:

Log Name	Entries	% Full	Latest Timestamped Entry
E - System Event	39	3 %	01 Nov 2004 17:15:03

Event Log Navigation Help:

```
+      View next block      (forward in time,  for example,from 3 to 4)
-      View previous block (backward in time, for example from 3 to 2)
<CR>  Continue to the next or previous block
D      Dump the entire log for capture and analysis
F      First entry
L      Last entry
J      Jump to entry number
H      View mode configuration - hex
K      View mode configuration - keyword
T      View mode configuration - text
A      Alert Level Filter options
U      Alert Level Unfiltered
?      Display this Help menu
Q      Quit and return to the Event Log Viewer Menu
Ctrl-B Exit command and return to the MP Main Menu
```

Step 4. Type **t** to select text mode.

Step 5. Type **d** to dump the log to the screen. (If desired, save this file for reference.)

Step 6. To decode the blinking state of System LED, review the entire SEL and look at events with alert level 3 and above.

For example:

```
Log Entry 24: 14 Feb 2003 15:27:02
```

```
Alert Level 3: Warning
```

```
Keyword: Type-02 1b0800 1771520
```

```
Hot Swap Cage: SCSI cable removed
```

```
Logged by: BMC;  Sensor: Cable / Interconnect - SCSI ChExt Cable
```

```
Data1: Device Removed/Device Absent
```

```
0x203E4D0AC6020220 FFFF0008F61B0300
```

```
Log Entry 73: 00:00:12
```

```
Alert Level 3: Warning
```

```
Keyword: Type-02 050301 328449
```

```
The server's built-in sensors have detected an open chassis door.
```

```
Logged by: BMC;  Sensor: Physical Security - Chassis Open
```

```
Data1: State Asserted
```

```
0x200000000C020570 FFFF010302050300
```

Troubleshooting Using Offline Support Tools

You can use the *ODE CD* to troubleshoot your HP 9000 rp4410 or HP 9000 rp4440 server by accessing the offline diagnostic environment ODE.

Offline Diagnostic Environment (ODE)

ODE is used to evaluate specific hardware components with a command line interface. To access ODE from your *ODE CD*, perform the following steps:

Step 1. Power on your HP server and insert the *ODE CD*.

Step 2. Boot the system to the PDC (BOOTADMIN, BCH, and so forth.) prompt. PDC prompts may differ on some computer models.

```
Main Menu: Enter command or menu>
```

Step 3. List the bootable devices by entering search: **search**

Step 4. Select the CD device that contains the *ODE CD*, for example:

```
p3
```

Step 5. Boot from that device by entering boot p3: **boot p3**

Step 6. You are asked to interact with the Initial System Loader (ISL) prompt. Enter yes: **y**

Step 7. From the ISL prompt, start the Offline Diagnostics Environment by entering ODE: **ODE**

The following commands are available at the ODE prompt:

Table 4-2 ODE Commands

Command	Description
help	To display a list and description of the available commands
help <command>	To display the additional information
help <var>	To display the additional information
ls	To list the ODE modules that will run on your computer
<module_name>	To run an ODE module interactively
run <module_name>	To run an ODE module non-interactively

Troubleshooting Using LED Indicators

The HP 9000 rp4410 and HP 9000 rp4440 servers have LED indicators located on the front control panel and an internal QuickFind diagnostic panel that you can use to determine if repair action is required. See Chapter 1, “Controls, Ports, and Indicators,” for descriptions of all LEDs on your server.

Front Control Panel LEDs

The front control panel LEDs show you the system status at a glance. If warning or attention lights are flashing, then you should query the QuickFind diagnostic panel or management processor for further information.

Figure 4-1 Front Control Panel LEDs

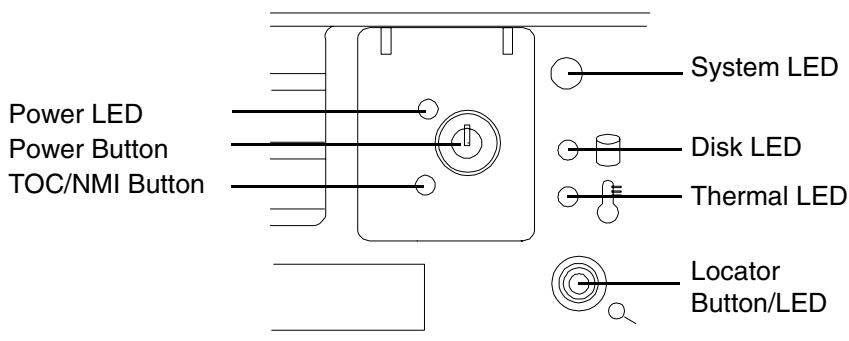

Table 4-3 Front Control Panel LED Definitions

LED/ Button	State	Flash Rate	Color	Description
System	Running	Steady	Green	Green: System normal—OS up and running
System	Booting	Flashing at 0.5 Hz	Green	Flashing green: OS booting or at BCH
System	Attention	Flashing at 1 Hz	Yellow	Flashing yellow: Warning—system needs attention. Redundancy lost, component failure pending. (Additional information can be found in the System Log)
System	Fault	Flashing at 2 Hz	Red	Flashing red: Hard fault, system halted
System	Off	Off	N/A	Off: System off
Power	On	Steady	Green	Green: Power normal
Power	On	Flashing at 1 Hz	Yellow	Flashing yellow: Housekeeping voltage present
Power	Off	Off	Off	Off: Power off

Table 4-3 Front Control Panel LED Definitions (Continued)

LED/ Button	State	Flash Rate	Color	Description
Disk LED		Flashing at rate of disk activity	Green	Flashing green: Disk activity
Thermal LED	OK	Steady	Green	Green: Thermal OK
Thermal LED	Warning	Flashing at 1 Hz	Yellow	Flashing Yellow: Thermal warning
Locator LED/button		Flashing at 1 Hz	Blue	Flashing Blue: System locator LED may be remotely or locally activated/deactivated

QuickFind Diagnostic Panel LEDs

The QuickFind diagnostic panel is located under the top cover and is attached to the top of the power supply cage. The following definitions describe the status of the various LEDs and what is wrong with the indicated component.

Table 4-4 QuickFind Diagnostic Panel LED Definitions

Item	LED 0	LED 1	LED 2	LED 3	Details
Processor	Socket 0	Socket 1	Socket 2	Socket 3	<p>If the System LED (on front panel) is in the attention or fault state and the processor LED is on, then the processor or voltage regulator has failed—the processor module in the specified socket needs to be replaced</p> <p>If the thermal LED is in the warning or critical state and the processor LED is on, then the processor exceeded the warning or critical level</p>
Subsystem	CPU board	Memory board	I/O board	n/a	A soldered voltage regulator has failed—the specified board must be replaced
I/O VRM	12 volt	5 volt	3 volt	n/a	A plug-in voltage regulator has failed—I/O baseboard must be replaced
CPU VRM	n/a	n/a	n/a	n/a	n/a
Fan module	0	1	2	n/a	<p>One or both fans in a fan module have failed—the module must be replaced</p> <p>Fan 2 is in front of the power supplies</p>
Memory bank X (0-7)	DIMM xA	DIMM xB	DIMM xC	DIMM xD	<p>The specified DIMM has failed—the DIMM must be replaced</p> <p>If all the LEDs for a rank (0-7) are lit and the Memory Config Error LED is lit, then the DIMMs in the specified rank are mismatched—replace mismatched DIMM</p>
Check power supply	n/a	n/a	n/a		One of the power supplies or power supply fans have failed—replace the power supply. The faulty power supply LED (located on power supply) will be lit
Memory config error	n/a	n/a	n/a		The DIMMs in a rank are mismatched. All the DIMMs in the specified rank (0-7) will be lit
Processor config error	n/a	n/a	n/a		The processors are mismatched—replace mismatched processor
Missing component	n/a	n/a	n/a		A required component(s) is not installed in the system and thus preventing power up

Table 4-4 QuickFind Diagnostic Panel LED Definitions (Continued)

Item	LED 0	LED 1	LED 2	LED 3	Details
System temp	n/a	n/a	n/a		The internal temperature of the server has exceeded the warning or critical level
Check event log	n/a	n/a	n/a		An event has occurred that requires attention

Figure 4-2 QuickFind Diagnostic Label

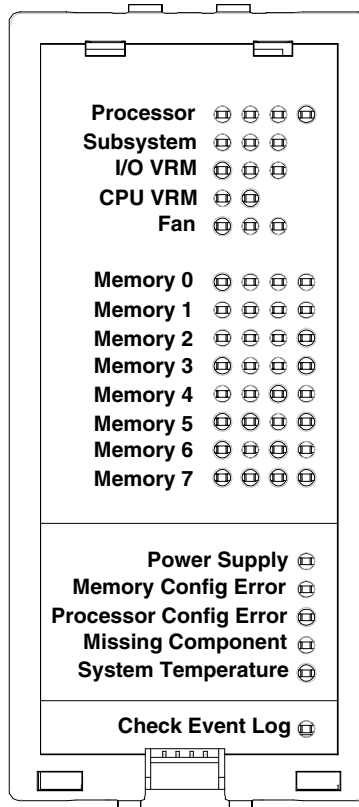

I/O Baseboard LED Indicators

Various LEDs, sensors, and reset or attention buttons are found on the I/O baseboard.

Figure 4-3 I/O Baseboard LEDs, Buttons, and Sensors

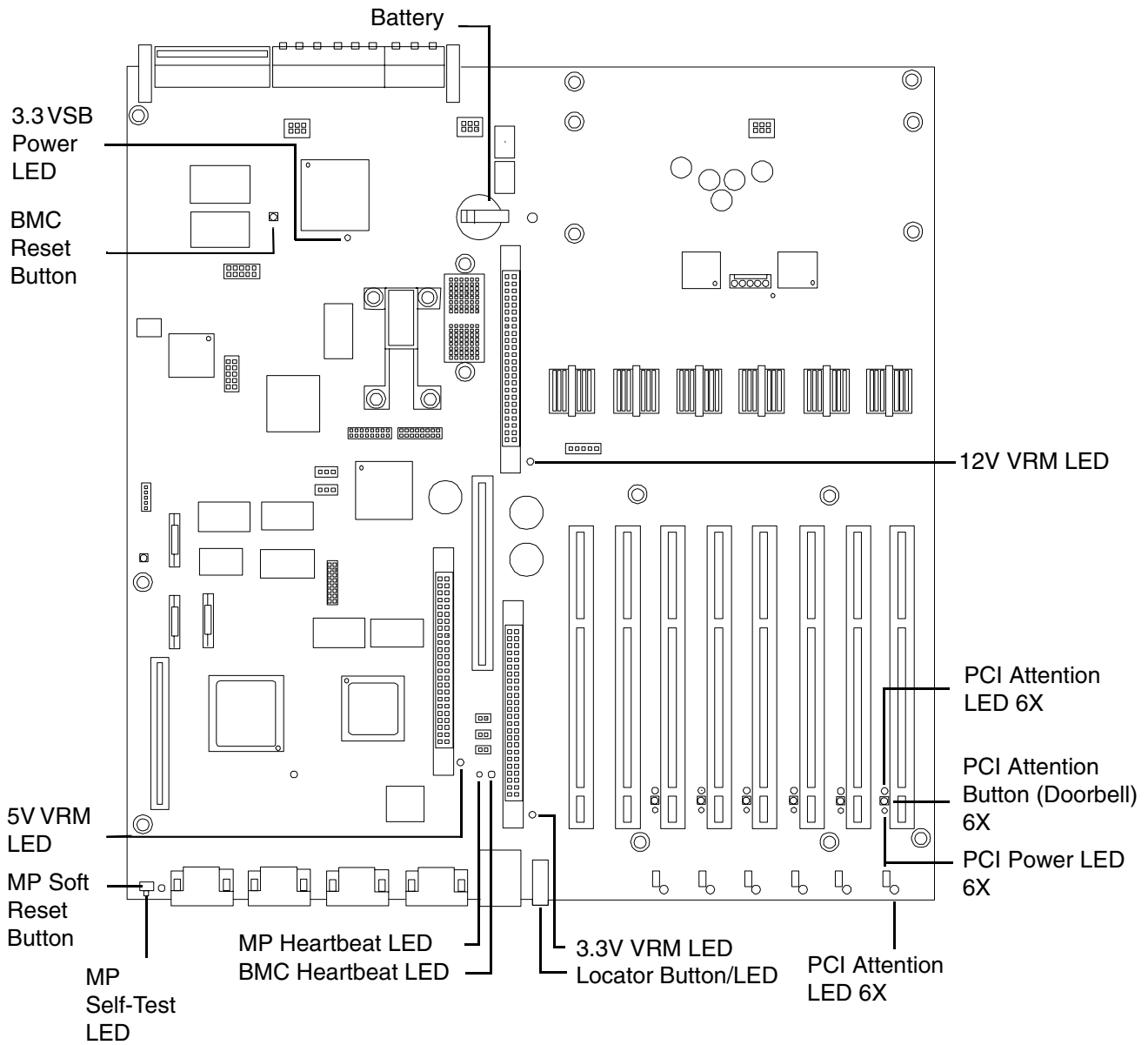

Table 4-5 I/O Baseboard LEDs, Buttons, and Sensors

LED/Button	Color	Status	Condition
12V VRM power LED	Green	On	12V VRM is functioning
5V VRM power LED	Green	On	5V VRM is functioning
3.3V VRM power LED	Green	On	3.3V VRM is functioning
MP heartbeat	Green	Blinking	The management processor is functioning correctly
MP self test LED	Amber	On	The management processor is executing the internal self test
		Off	The management processor has passed the internal self test
BMC heartbeat	Green	Blinking	The baseboard management controller is functioning correctly
3.3 VSB power LED	Green	On	Standby power is available
MP soft reset button	N/A	Press	Resets the management processors values

Memory Extender Boards

The 32 DIMM memory extender board has two power status LEDs (1.25V and 1.5V). See Figure 4-4 on page 62. When the LEDs are on, each respective voltage is present on the memory extender board.

The 16 DIMM memory extender board has one condition LED on each of the two VRMs. If either condition VRM LED is on, there is a problem with that VRM. You must replace the entire extender board in this case; the VRMs are not field replaceable units (FRUs).

Figure 4-4 32 DIMM Memory Extender Board LEDs

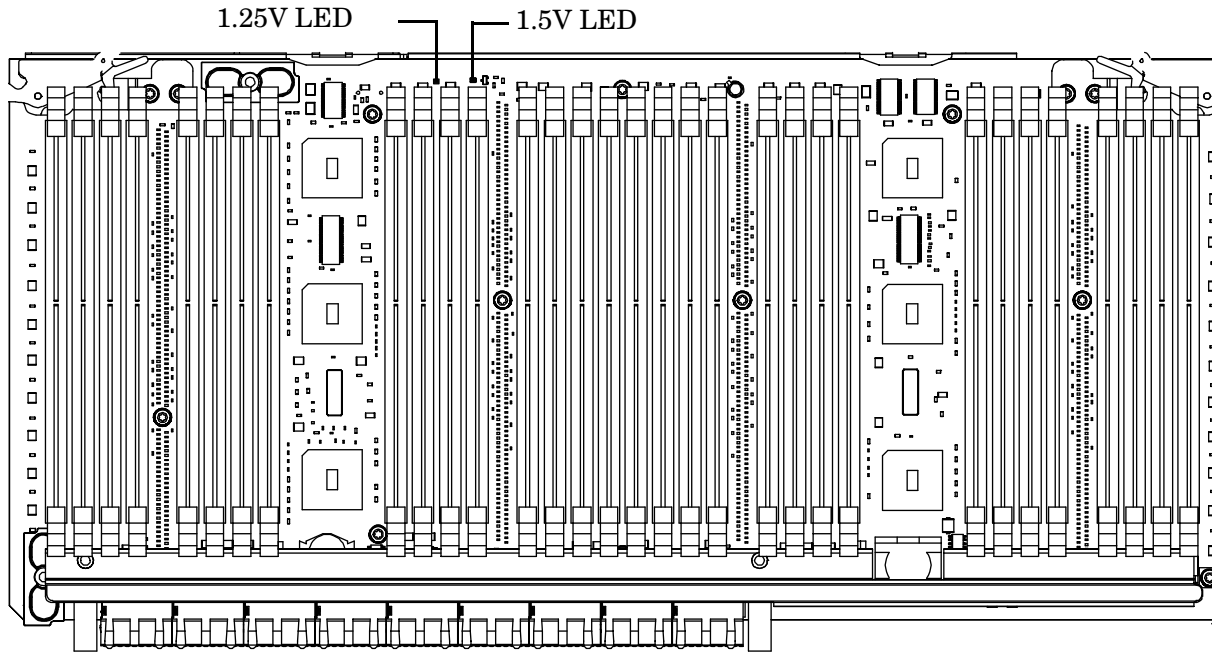

Table 4-6 32 DIMM Memory Extender Board

LED	Color	Status	Condition
1.25V power	Green	On	Power OK
1.5V power	Green	On	Power OK

Figure 4-5 16 DIMM Memory Extender Board LEDs

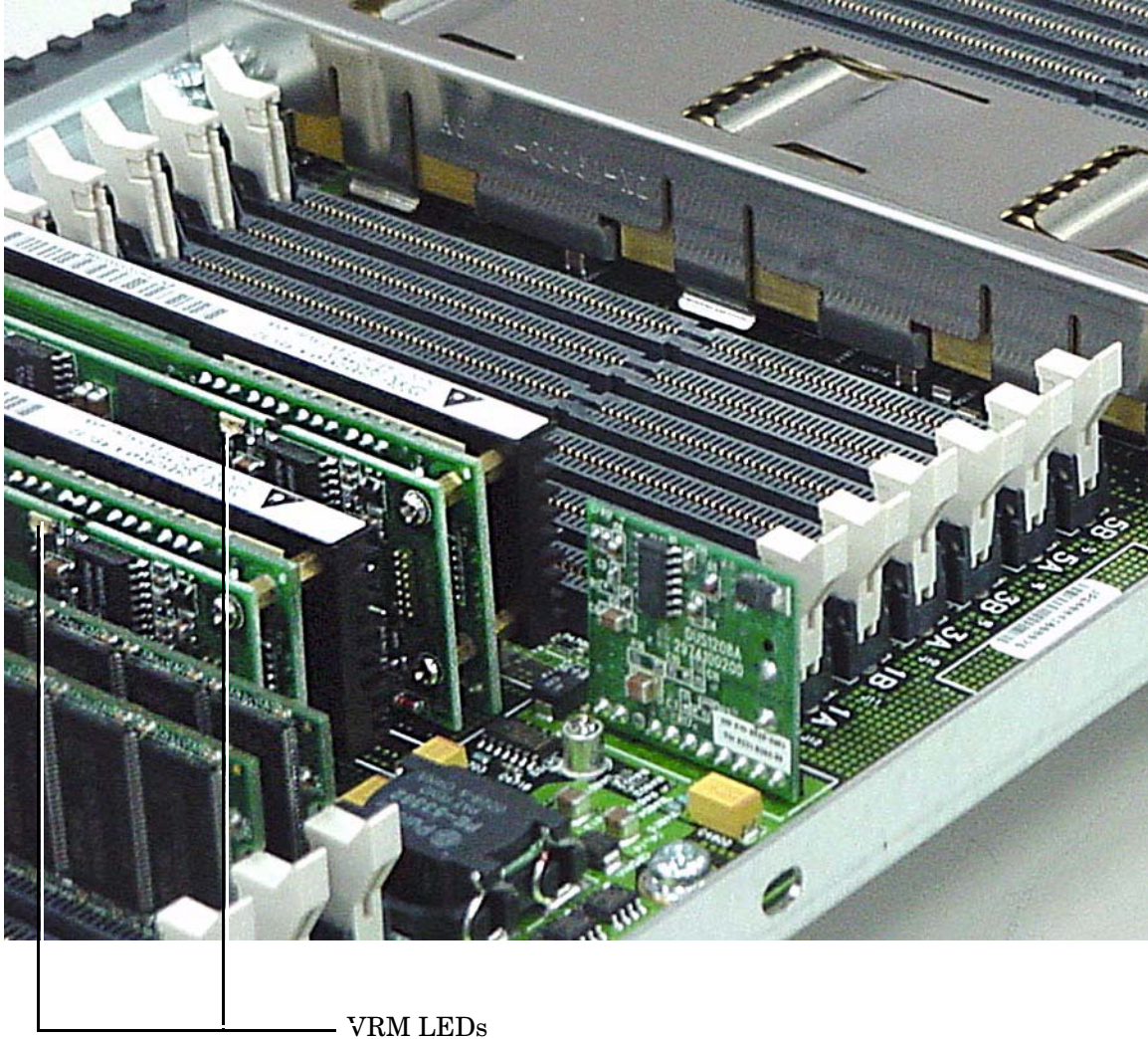

Table 4-7 16 DIMM Memory Extender Board

LED	Color	Status	Condition	Action
VRM status	Green	On	VRM is bad	Replace memory extender board

5 Specifications

Introduction

This chapter provides the power requirements, operating conditions (environmental requirements), physical requirements, and hardware specifications of the HP 9000 rp4410 and HP 9000 rp4440 servers. The following tables provide the specifications required for normal operation of your HP server.

NOTE The specifications and requirements for the power supply and environment can vary if you install a mass storage device in the server that has more stringent environmental limits than required for the HP server. Ensure the operating environment for any mass storage devices you intend to install are compatible with the server environmental requirements.

Hardware Specifications

Table 5-1 Hardware Specifications

Microprocessors	One or two dual processor modules in the HP 9000 rp4410 server Up to four dual processor modules in the HP 9000 rp4440 server Each dual processor module contains two PA-RISC microprocessors Options include: 800 MHz processors with 32 MB L2 cache 800 MHz processors with 64 MB L2 cache 1 GHz processors with 32 MB L2 cache 1 GHz processors with 64 MB L2 cache
Memory	Supports up to 32 Double Data Rate (DDR) registered ECC memory, in PC2100 DIMMs. Supported DDR DIMM sizes: 128 MB, 256 MB, 513 MB, 1 GB, 2 GB, and 4 GB. Requires that DIMMs within each group of 4 (quad) be identical
Video	Pinnacle FXe PCI card
SCSI	Integrated Ultra-3 SCSI dual channel controller; 80 MB/s transfer rate with two 68-pin connectors
Integrated HP RAID controller	Optional
LAN	PCI Gigabit, Fast Ethernet Controller; with Wake-on-LAN enabled/disabled with BIOS setup
PCI slots	Four 64-bit PCI-X slots, 66 MHz slots Two 64-bit PCI-X slots, 133 MHz slots
Core I/O	Three serial ports, two USB ports, integrated RJ-45 LAN
DVD-ROM	DVD-R/CD-ROM drive; IDE interface; 48x speed
Mass storage	Maximum internal storage: Two 73 MB, 15K drive

Table 5-1 Hardware Specifications (Continued)

External storage	2 external SCSI ports
Power supply	1+1 configuration, redundant power supply (optional)

Server Dimensions and Weights

This section provides dimensions and weights of the HP 9000 rp4410 and HP 9000 rp4440 server components.

Component Dimensions

Table 5-2 Server Component Dimensions

Dimension	Value
Height	6.87" (17.46 cm)
Width	17.32" (44 cm)
Depth	27.1" (68.8 cm)
Weight: rp4410	Unloaded 75 lbs (34 kg) Fully loaded <95 lbs (43 kg)
Weight: rp4440	Unloaded 75 lbs (34 kg) Fully loaded <95 lbs (43 kg)

B

- BCH Commands, 33
 - Information Menu, 36
 - Main Menu, 34
 - Service Menu, 37
- Boot Console Handler (BCH), 33
 - Boot Paths, 33
 - Commands, 33

C

- command interface *See also* MP Main Menu
 - commands, 46
- Command Menu commands, 46, 46–??
- Commands
 - BCH Commands, 33
 - Configuration Menu, 35
 - Information Menu, 36
 - Main Menu, 34
 - Service Menu, 37
- Control Panel, 13, 56
- Controls
 - CD/DVD Controls, 16
 - Disk Drive Controls, 15
 - Front Panel Controls, 12

D

- Dimensions, 67
- Disk Drive
 - Controls and Indicators, 15
- DVD ROM Drive
 - Controls and Indicators, 16
- dynamic DNS *See* DDNS

E

- Ethernet card LAN LEDs, 24
- Ethernet LAN Port, 30
- Event Logs
 - Current Boot, 53
 - FPL, 53
 - Previous Boot, 53
 - SEL, 53
- Event Monitoring Service, EMS, 52
- External Connectors, 27

F

- Front Panel
 - Description, 12

G

- Gigabit Ethernet card LAN LEDs, 24
- Gigabit Ethernet LAN port, 30

H

- Hot-Plug Disk Drives
 - LEDs, 15
- HyperTerm, 40

I

- I/O Baseboard
 - LEDs, Buttons, and Sensors, 19, 60
- iLO
 - overview, 39–??
- iLO *See also* MP
- Integrated Lights-Out Management Processor *See* iLO

L

- LAN port
 - configuring a static IP address (non-DHCP), 40
 - configuring the IP address, 40–41
- LEDs
 - Core I/O Single Port LAN LEDs, 24
 - DIMM Memory Extender Board, 62
 - Dual Port LAN Core I/O Card LEDs, 25
 - Front Control Panel, 14, 56
 - Gigabit Ethernet LAN, 24
 - Hot-Plug Disk Drives, 15
 - I/O Baseboard, 19, 60
 - Locator, 23
 - Management Processor, 23
 - Power Supply Status, 22
 - QuickFind Diagnostic Panel, 18, 58
 - Rear Panel, 23
 - Troubleshooting, 56
- Logs
 - Current Boot, 53
 - FPL, 53
 - Line Events, 53
 - Previous Boot, 53
 - SEL, 53

M

- Management Processor
 - Description, 52
 - LEDs, 23
 - Soft Reset, 20
- management processor *See* iLO
- Memory Extender Boards
 - 16 DIMM Extender Boards, 61
 - 32 DIMM Extender Boards, 61
 - LEDs, 62
- MP
 - accessing, 41
 - commands, 44
 - configuring for LAN, 43
 - interacting with, 42
 - local terminal access to, 41
 - Main Menu, 42
- MP LAN port IP address
 - configuring a static IP address (non-DHCP), 40
 - configuring an IP address (DHCP), 43
 - LC command, 44
- MP Main Menu commands, 46–??
- MP *See also* iLO

Index

N

NMI Button, 15

O

Offline Diagnostic Environment, ODE, 55
Operating System Will Boot, Troubleshooting, 51

P

Path (BCH), 33
Pinouts, Connector, 27
 Gigabit Ethernet (LAN) Port, 30
 MP LAN port, 29
 SCSI port, 31
 Serial port, 29
 USB connector, 28
 Video connector, 28
Power Button, 14, 50
Power Supply, Status LED, 22
Putty, 40

Q

QuickFind Diagnostic Panel
 Accessing, 17
 LEDs, 18, 58
 Troubleshooting, 56

R

Rear Panel, 21
Reflection 1, 40

S

SCSI Connector Pinout, 31
Serial Port
 Connector pinout, 29
SL, 53
Specifications, 65
static IP address (non-DHCP)
 configuring, 41
 configuring the MP LAN port, 40
 set up local terminal access, 40
Support Tools Manager, 52
System Event Log, 53

T

terminal access, 40
Troubleshooting, 49
 Methodology, 49
 Using LEDs, 56
 Using Offline Support Tools, 55
 Offline Diagnostic Environment (OED), 55
 Using Online Support Tools, 52
 Event Monitoring Service (EMS), 52
 Management Processor (MP), 52
 Support Tools Manager (STM), 52

U

Universal Serial Bus, 28

V

VGA Port, 28

W

Weight, 67