

User Service Guide

HP Integrity rx8640 Server, HP 9000 rp8440 Server

Third Edition



Manufacturing Part Number : AB297-9003C

January 2007

USA

© Copyright 2007

Legal Notices

© Copyright 2007 Hewlett-Packard Development Company, L.P.

The information contained herein is subject to change without notice.

The only warranties for HP products and services are set forth in the express warranty statements accompanying such products and services. Nothing herein should be construed as constituting an additional warranty. HP shall not be liable for technical or editorial errors or omissions contained herein.

Microsoft and Windows are U.S. registered trademarks of Microsoft Corporation. Linux is a U.S. registered trademark of Linus Torvalds. Intel is a trademark or registered trademark of Intel Corporation or its subsidiaries in the United States and other countries.

1. HP Integrity rx8640 and HP 9000 rp8440 Server Overview

Detailed Server Description	22
Dimensions and Components	23
Front Panel	26
Cell Board	27
Cells and nPartitions	32
Internal Disk Devices	34
System Backplane	36
I/O Subsystem	37

2. System Specifications

Dimensions and Weights	43
Electrical Specifications	45
Grounding	45
Circuit Breaker	45
System AC Power Specifications	45
System Power Specifications	46
Environmental Specifications	49
Temperature and Humidity	49
Cooling	51
Typical HP Integrity rx8640 Power Dissipation and Cooling	52
Typical HP 9000 rp8440 Power Dissipation and Cooling	53
Acoustic Noise Specification	53
Air Flow	53

3. Installing the System

Receiving and Inspecting the Server Cabinet	57
Unpacking the Server Cabinet	57
Securing the Cabinet	61
Standalone and To-Be-Racked Systems	62
Rack-Mount System Installation	62
Lifting the Server Cabinet Manually	63
Using the RonI Model 17000 SP 400 Lifting Device	64
Installing the Wheel Kit	67
Installing the Top and Side Covers	75
Removing the Top Cover	75
Installing the Top Cover	76
Removing the Side Cover	76
Installing the Side Cover	77
Installing the Power Distribution Unit	78
Installing Additional Cards and Storage	79
Installing an Additional Hard Disk Drive	79
Removable Media Drive Installation	80
HP Integrity rx8640 Supported PCI/PCI-X I/O Cards	82
HP 9000 rp8440 Supported PCI/PCI-X I/O cards	84
Installing an Additional PCI-X I/O Card	86

Contents

Installing an A6869B VGA/USB PCI Card in a Server	88
Troubleshooting the A6869B VGA/USB PCI Card	89
System Console Selection	91
VGA Consoles	92
Interface Differences Between Itanium-based Systems	92
Other Console Types	92
Additional Notes on Console Selection	92
Cabling and Powering On the Server	93
Checking the Voltage	93
Voltage Check (Additional Procedure)	97
Connecting AC Input Power	98
Installing The Line Cord Anchor (rack mounted servers)	101
MP Core I/O Connections	103
Setting Up the Customer Engineer Tool (PC)	103
Turning On Housekeeping Power and Logging In to the MP	105
Configuring LAN Information for the MP	108
Accessing the Management Processor via a Web Browser	110
Verifying the Presence of the Cell Boards	112
Configuring AC Line Status	113
Booting the Server	113
Adding Processors for HP Integrity rx8640 with Instant Capacity	116
Installation Checklist	116

4. Booting and Shutting Down the Operating System

Operating Systems Supported on Cell-based HP Servers	121
System Boot Configuration Options	123
HP 9000 Boot Configuration Options	123
HP Integrity Boot Configuration Options	123
Booting and Shutting Down HP-UX	128
HP-UX Support for Cell Local Memory	128
Adding HP-UX to the Boot Options List	128
Booting HP-UX	129
Shutting Down HP-UX	138
Booting and Shutting Down HP OpenVMS I64	140
HP OpenVMS I64 Support for Cell Local Memory	140
Adding HP OpenVMS to the Boot Options List	140
Booting HP OpenVMS	142
Shutting Down HP OpenVMS	143
Booting and Shutting Down Microsoft Windows	145
Microsoft Windows Support for Cell Local Memory	145
Adding Microsoft Windows to the Boot Options List	145
Booting Microsoft Windows	147
Shutting Down Microsoft Windows	148
Booting and Shutting Down Linux	150
Linux Support for Cell Local Memory	150
Adding Linux to the Boot Options List	150

Booting Red Hat Enterprise Linux	152
Booting SuSE Linux Enterprise Server	153
Shutting Down Linux	154

5. Server Troubleshooting

Common Installation Problems.	157
The Server Does Not Power On	158
The Server Powers On But Then Shuts Down with a Fault Light	158
The Server Powers On But Fails Power-On Self Test.	158
Server LED Indicators.	159
Front Panel LEDs	159
Bulk Power Supply LEDs.	161
PCI Power Supply LEDs.	162
System and I/O Fan LEDs	163
OL* LEDs	164
PCI OL* Card Divider LEDs	166
Core I/O LEDs.	167
Core I/O Buttons	168
Disk Drive LEDs.	170
Interlock Switches	170
Server Management Subsystem Hardware Overview.	171
Server Management Overview	172
Server Management Behavior.	173
Thermal Monitoring	173
Fan Control	173
Power Control	174
Updating Firmware	175
Firmware Manager.	175
Using FTP to Update Firmware	175
Possible Error Messages.	176
PDC Code CRU Reporting.	177

6. Removing and Replacing Components

Customer Replaceable Units (CRUs)	181
Hot-Plug CRUs	181
Hot-Swap CRUs	181
Safety and Environmental Considerations	182
Communications Interference	182
Electrostatic Discharge	182
Powering Off Hardware Components and Powering On the Server	184
Powering Off Hardware Components	184
Powering On the System	185
Removing and Replacing Covers.	186
Removing the Top Cover.	186
Replacing the Top Cover.	187
Removing the Side Cover	187

Contents

Replacing the Side Cover	188
Removing and Replacing the Front Bezel	189
Removing and Replacing the Front Smart Fan Assembly	190
Removing the Front Smart Fan Assembly	190
Replacing the Front Smart Fan Assembly	191
Removing and Replacing the Rear Smart Fan Assembly	192
Removing the Rear Smart Fan Assembly	192
Replacing the Rear Smart Fan Assembly	193
Removing and Replacing a Disk Drive	194
Removing the Disk Drive	194
Replacing the Disk Drive	195
Removing and Replacing a Removable Media Drive	196
Removing the Removable Media Drive	196
Replacing the Removable Media Drive	197
Removing and Replacing a PCI Card	198
Removing the PCI Card	198
Option ROM	200
Removing and Replacing a PCI Smart Fan Assembly	202
Preliminary Procedures	202
Removing the PCI Smart Fan Assembly	203
Replacing the PCI Smart Fan Assembly	203
Removing and Replacing a PCI Power Supply	204
Preliminary Procedures	205
Removing the PCI Power Supply	205
Replacing the PCI Power Supply	206
Removing and Replacing a Bulk Power Supply (BPS)	207
Cell Board Power Requirements	207
Removing the BPS	209
Replacing the BPS	210
A. Replaceable Parts	
Replaceable Parts List	213
B. MP Commands	
Server Management Commands	217
C. Templates	
Equipment Footprint Templates	221
Computer Room Layout Plan	222
Index	227

Table 1-1. Cell Board CPU Module Load Order	29
Table 1-2. DIMM Sizes Supported.	31
Table 1-3. DIMM Load Order	32
Table 1-4. Removable Media Drive Path.	34
Table 1-5. Hard Disk Drive Path.	34
Table 1-6. PCI-X Slot Boot Paths Cell 0	38
Table 1-7. PCI-X Slot Boot Paths Cell 1	39
Table 1-8. PCI-X Slot Types.	40
Table 2-1. Server Dimensions and Weights	43
Table 2-2. Server Component Weights	43
Table 2-3. Example Weight Summary.	44
Table 2-4. Weight Summary	44
Table 2-5. Power Cords.	45
Table 2-6. HP Integrity rx8640 and HP 9000 rp8440 AC Power Requirements.	46
Table 2-7. HP Integrity rx8640 System Power Requirements.	47
Table 2-8. HP 9000 rp 8440 System Power Requirements.	48
Table 2-9. Example ASHRAE Thermal Report.	50
Table 2-10. Typical HP Integrity rx8640 Server Configurations.	52
Table 2-11. Typical HP 9000 rp8440 Server Configurations	53
Table 3-1. Wheel Kit Packing List.	67
Table 3-2. HP Integrity rx8640 Server PCI-X I/O Cards	82
Table 3-3. HP 9000 rp8440 Server PCI-X I/O Cards	84
Table 3-4. Single Phase Voltage Examples	94
Table 3-5. BPS-to-Cell Board Configuration to Maintain N+1	100
Table 3-6. Factory-Integrated Installation Checklist.	117
Table 5-1. Front Panel LEDs	159
Table 5-2. BPS LEDs	161
Table 5-3. PCI-X Power Supply LEDs.	162
Table 5-4. Front, Rear, and I/O Fan LEDs	163
Table 5-5. Cell Board OL* LED Indicators	165
Table 5-6. OL* LED States	166
Table 5-7. Core I/O LEDs	168
Table 5-8. Core I/O Buttons	169
Table 5-9. Disk Drive LEDs	170
Table 6-1. Smart Fan Assembly LED States	191
Table 6-2. Smart Fan Assembly LED Indications	202
Table 6-3. PCI-X Power Supply LEDs.	205
Table 6-4. N+1 BPS-to-Cell Board Configuration.	207
Table 6-5. BPS LED Definitions	209
Table A-1. Server CRU Descriptions and Part Numbers.	213
Table B-1. Management Commands	217
Table B-2. Status Commands	217
Table B-3. System and Access Configuration Commands	217

Figure 1-1. 16-Socket Server Block Diagram	22
Figure 1-2. Server (Front View With Bezel)	23
Figure 1-3. Server (Front View Without Bezel)	24
Figure 1-4. Server (Rear View)	25
Figure 1-5. Front Panel LEDs and Power Switch	26
Figure 1-6. Cell Board	27
Figure 1-7. Socket Locations on Cell Board	29
Figure 1-8. Memory Subsystem.	30
Figure 1-9. DIMM Slot Layout	32
Figure 1-10. Internal Disks Locations	34
Figure 1-11. System Backplane Block Diagram.	36
Figure 1-12. PCI-X Board to Cell Board Block Diagram	38
Figure 1-13. Mass Storage Block Diagram	41
Figure 2-1. Airflow Diagram	54
Figure 3-1. Removing the Polystraps and Cardboard	58
Figure 3-2. Removing the Shipping Bolts and Plastic Cover	59
Figure 3-3. Preparing to Roll Off the Pallet.	60
Figure 3-4. Securing the Cabinet	61
Figure 3-5. Positioning the Lifter to the Pallet	65
Figure 3-6. Raising the Server Off the Pallet Cushions	66
Figure 3-7. Server on Shipping Pallet.	68
Figure 3-8. Removing Cushion from Front Edge of Server	69
Figure 3-9. Attaching a Caster Wheel to the Server	70
Figure 3-10. Attaching the Ramp to the Pallet.	71
Figure 3-11. Removing Side Cushion from Server	72
Figure 3-12. Securing Each Caster Cover to the Server	73
Figure 3-13. Completed Wheel Kit Installation	74
Figure 3-14. Cover Locations.	75
Figure 3-15. Top Cover Detail	76
Figure 3-16. Side Cover Detail	77
Figure 3-17. Disk Drive Location	79
Figure 3-18. Removable Media Drive Location	80
Figure 3-19. PCI I/O Slot Details	87
Figure 3-20. PCI/PCI-X Card Location	89
Figure 3-21. Console Output Device menu	91
Figure 3-22. Voltage Reference Points for IEC-320 C19 Plug	93
Figure 3-23. Safety Ground Reference Check — Single Power Source	94
Figure 3-24. Safety Ground Reference Check — Dual Power Source	95
Figure 3-25. Wall Receptacle Pinouts.	97
Figure 3-26. AC Power Input Labeling	98
Figure 3-27. Distribution of Input Power for Each Bulk Power Supply	99
Figure 3-28. Four Cell Line Cord Anchor (rp8400, rp8420, rp8440, rx8620, rx8640)	101
Figure 3-29. Line Cord Anchor and Velcro straps	102

Figures

Figure 3-30. LAN and RS-232 Connectors on the Core I/O Board	105
Figure 3-31. Front Panel Display	106
Figure 3-32. BPS LED Location	107
Figure 3-33. MP Main Menu	108
Figure 3-34. The lc Command Screen	109
Figure 3-35. The ls Command Screen	110
Figure 3-36. Example sa Command	111
Figure 3-37. Browser Window	111
Figure 3-38. The du Command Screen	112
Figure 3-39. The pwrgrd Command Screen	113
Figure 5-1. Front Panel with LED Indicators	159
Figure 5-2. BPS LED Location	161
Figure 5-3. PCI Power Supply LED Locations	162
Figure 5-4. Fan LED Locations	163
Figure 5-5. Cell Board LED Locations	164
Figure 5-6. PCI OL* LED Locations	166
Figure 5-7. Core I/O Card Bulkhead LEDs	167
Figure 5-8. Core I/O Button Location	168
Figure 5-9. Disk Drive LED Location	170
Figure 5-10. Temperature States	173
Figure 5-11. Firmware Update Command Example	176
Figure 5-12. Server Cabinet CRUs (Front View)	177
Figure 5-13. Server Cabinet CRUs (Rear View)	178
Figure 6-1. Cover Locations	186
Figure 6-2. Top Cover Removed	187
Figure 6-3. Side Cover Removal Detail	188
Figure 6-4. Bezel Removal and Replacement	189
Figure 6-5. Front Smart Fan Assembly Location	190
Figure 6-6. Front Fan Removal	191
Figure 6-7. Rear Smart Fan Assembly Location	192
Figure 6-8. Rear Fan Detail	193
Figure 6-9. Disk Drive Location	194
Figure 6-10. Disk Drive Detail	195
Figure 6-11. Removable Media Drive Location	196
Figure 6-12. Removable Media Drive Detail	197
Figure 6-13. PCI Card Location	198
Figure 6-14. PCI I/O Slot Details	199
Figure 6-15. PCI Smart Fan Assembly Location	202
Figure 6-16. PCI Smart Fan Assembly Detail	203
Figure 6-17. PCI Power Supply Location	204
Figure 6-18. PCI Power Supply Detail	206
Figure 6-19. BPS Location (Front Bezel Removed)	208
Figure 6-20. BPS Detail	210

Figure C-1. Server Space Requirements	220
Figure C-2. Server Cabinet Template	223
Figure C-3. Planning Grid	224
Figure C-4. Planning Grid	225

About this Document

This document covers the HP Integrity rx8640 and HP 9000 rp8440 servers.

This document does not describe system software or partition configuration in any detail. For detailed information concerning those topics, refer to the HP System Partitions Guide: Administration for nPartitions.

Book Layout

This document contains the following chapters and appendices:

- Chapter 1 - System Overview
- Chapter 2 - System Specifications
- Chapter 3 - Installing the System
- Chapter 4 - Booting and Shutting Down the Operating System
- Chapter 5 - Server Troubleshooting
- Chapter 6 - Removing and Replacing Components
- Appendix A - Replaceable Parts
- Appendix B - MP Commands
- Appendix C - Templates
- Index

Intended Audience

This document is intended to be used by customer engineers assigned to support HP Integrity rx8640 and HP 9000 rp8440 servers.

Publishing History

The following publishing history identifies the editions and release dates of this document. Updates are made to this document on an unscheduled, as needed, basis. The updates will consist of a new release of this document and pertinent online or CD-ROM documentation.

First Edition	March 2006
Second Edition	September 2006
Third Edition	January 2007



READ ME

Warranty Information

Each HP product is sold subject to the HP express limited warranty statement relating to that product. The *BCS Global Limited Warranty and Technical Support* statement provides important information about the nature and scope of the express limited warranty provided from the HP product, and contains certain disclaimers and limitations of liability by HP, which materially impact your rights. Accordingly, you are strongly advised to read carefully the *BCS Global Limited Warranty and Technical Support* statement before using your HP product. Your use of the HP product is deemed to be acceptance of the terms and conditions set forth in the *BCS Global Limited Warranty and Technical Support* statement.

You can view, print, or download the *BCS Global Limited Warranty and Technical Support* statement for your HP Enterprise Server product from our website at:

<http://docs.hp.com/en/hw.html>

Select your system hardware and then click on the "BCS Global Limited Warranty and Technical Support" pdf link provided in the list of documentation.

To obtain warranty service for your HP 9000 Server (PA-RISC product family)

- Support can be obtained from US & Canada at: **1-800-633-3600**

To obtain warranty service for your HP Integrity Server (IPF-based product family)

- Warranty and support information for Itanium-based sever products is available on the Web at:

<http://www.hp.com/support/itaniumservers>

- Support can be obtained from US & Canada at: **1-800-593-6631**
- For Worldwide locations, visit:

http://welcome.hp.com/country/us/en/wwcontact_us.html

You will be asked to provide the product number & serial number and may be required to provide dated proof of purchase.

Product Technical Documentation

To obtain technical installation and support information pertaining to this product, refer to the following web site:

<http://docs.hp.com>

Server Support Information

For online access to technical support information, self-solve tools, online assistance, community forums of IT experts, broad multi-vendor knowledge base, monitoring and diagnostic tools, refer to the following web site:

<http://www.hp.com/support>

To subscribe to HP's driver and support alerts/notifications program, refer to the following web site:

<http://www.hp.com/go/eupdates>

Related Information

You can access other information on HP server hardware management, Microsoft® Windows® administration, and diagnostic support tools at the following Web sites:

<http://docs.hp.com>

The main Web site for HP technical documentation is <http://docs.hp.com>.

Server Hardware Information:
<http://docs.hp.com/hpux/hw/>

The <http://docs.hp.com/hpux/hw/> Web site is the systems hardware portion of docs.hp.com. It provides HP nPartition server hardware management information, including site preparation, installation, and more.

Windows Operating System Information

You can find information about administration of the Microsoft® Windows® operating system at the following Web sites, among others:

- http://docs.hp.com/windows_nt/
- <http://www.microsoft.com/technet/>

Diagnostics and Event Monitoring: Hardware Support Tools

Complete information about HP hardware support tools, including online and offline diagnostics and event monitoring tools, is at the <http://docs.hp.com/hpux/diag/> Web site. This site has manuals, tutorials, FAQs, and other reference material.

Web Site for HP Technical Support:
<http://us-support2.external.hp.com>

HP IT resource center Web site at <http://us-support2.external.hp.com/> provides comprehensive support information for IT professionals on a wide variety of topics, including software, hardware, and networking.

Books about HP-UX Published by Prentice Hall

The <http://www.hp.com/hpbooks/> Web site lists the HP books that Prentice Hall currently publishes, such as HP-UX books including:

- *HP-UX 11i System Administration Handbook and Toolkit*
http://www.hp.com/hpbooks/prentice/ptr_0130600814.html
- *HP-UX Virtual Partitions*
http://www.hp.com/hpbooks/prentice/ptr_0130352128.html

HP books are available worldwide through bookstores, online booksellers, and office and computer stores.

Typographic Conventions

The following notational conventions are used in this publication.

WARNING A warning lists requirements that you must meet to avoid personal injury.

CAUTION A caution provides information required to avoid losing data or avoid losing system functionality.

NOTE A note highlights useful information such as restrictions, recommendations, or important details about HP product features.

- Commands and options are represented using this font.
- **Text that you type exactly as shown** is represented using **this font**.
- *Text to be replaced with text that you supply* is represented using *this font*.

Example:

“Enter the `ls -l filename` command” means you must replace *filename* with your own text.

- **Keyboard keys and graphical interface items (such as buttons, tabs, and menu items)** are represented using **this font**.

Examples:

The **Control** key, the **OK** button, the **General** tab, the **Options** menu.

- **Menu → Submenu** represents a menu selection you can perform.

Example:

“Select the **Partition → Create Partition** action” means you must select the **Create Partition** menu item from the **Partition** menu.

- Example screen output is represented using this font.

HP Encourages Your Comments

Hewlett-Packard welcomes your feedback on this publication. Please address your comments to **edit@presskit.rsn.hp.com** and note that you will not receive an immediate reply. All comments are appreciated.

1 HP Integrity rx8640 and HP 9000 rp8440 Server Overview

The HP Integrity rx8640 server and the HP 9000 rp8440 server are members of the HP business-critical computing platform family of mid-range, mid-volume servers, positioned between the HP Integrity rx7640, HP 9000 rp7440 and HP Integrity Superdome servers.

IMPORTANT The HP Integrity rx8640 and the HP 9000 rp8440 are both sx2000-based systems and share common hardware and technology throughout.

The server is a 17U¹ high, 16-socket symmetric multiprocessor (SMP) rack-mount or standalone server.

Features of the server include:

- Up to 512 GB of physical memory provided by dual inline memory modules (DIMMs).
- Up to 32 processors with a maximum of 4 processor modules per cell board and a maximum of 4 cell boards. Supports dual-core processors.
- One cell controller (CC) per cell board.
- Turbo fans to cool CPUs and CCs on the cell boards.
- Up to four embedded hard disk drives.
- Up to two internal DVD drives or one DVD drive and one DDS-4 DAT drive.
- Nine front chassis mounted N+1 fans.
- Twelve rear chassis mounted N+1 fans.
- Six N+1 PCI-X card cage fans.
- Up to six N+1 bulk power supplies.
- Two N+1 PCI-X power supplies
- N+1 hot-swappable system clock oscillators.
- Sixteen PCI-X slots divided into two partitions. Each partition can accommodate up to eight PCI/PCI-X/PCI-X 2.0 cards.
- Up to two core I/O cards.
- One failover service processor per core I/O card.
- Four 220 V AC power plugs. Two are required and the other two provide power source redundancy.

1. The U is a unit of measurement specifying product height. One U is equal to 1.75 inches.

Detailed Server Description

The following section provides detailed information about the server components.

Figure 1-1 16-Socket Server Block Diagram

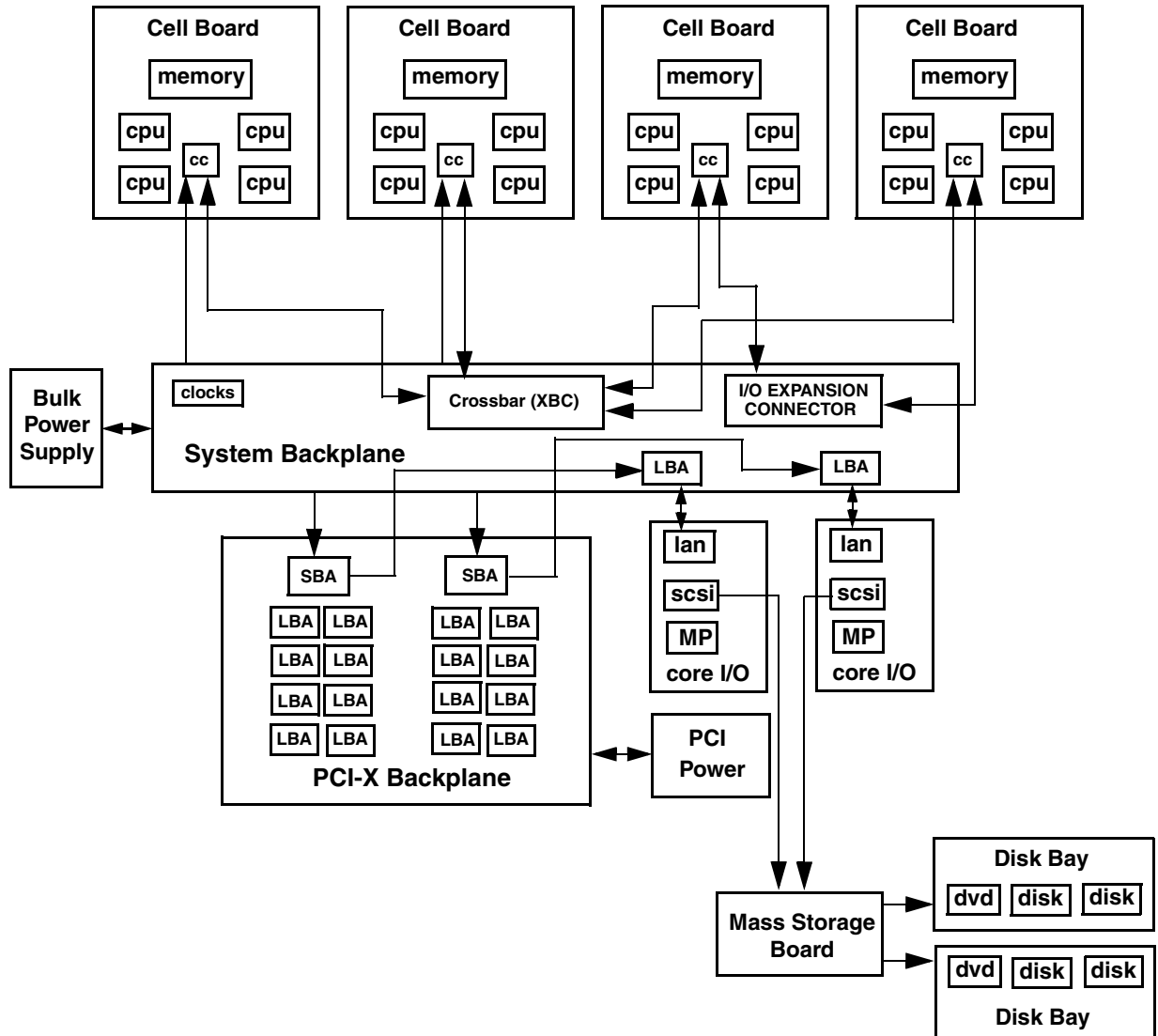

Dimensions and Components

The following section describes server dimensions and components.

Figure 1-2 Server (Front View With Bezel)

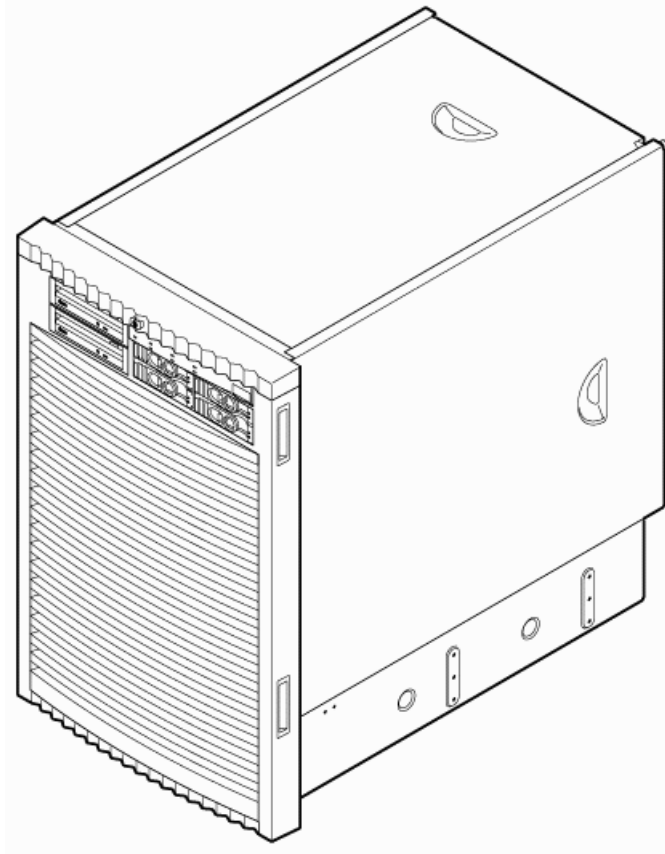
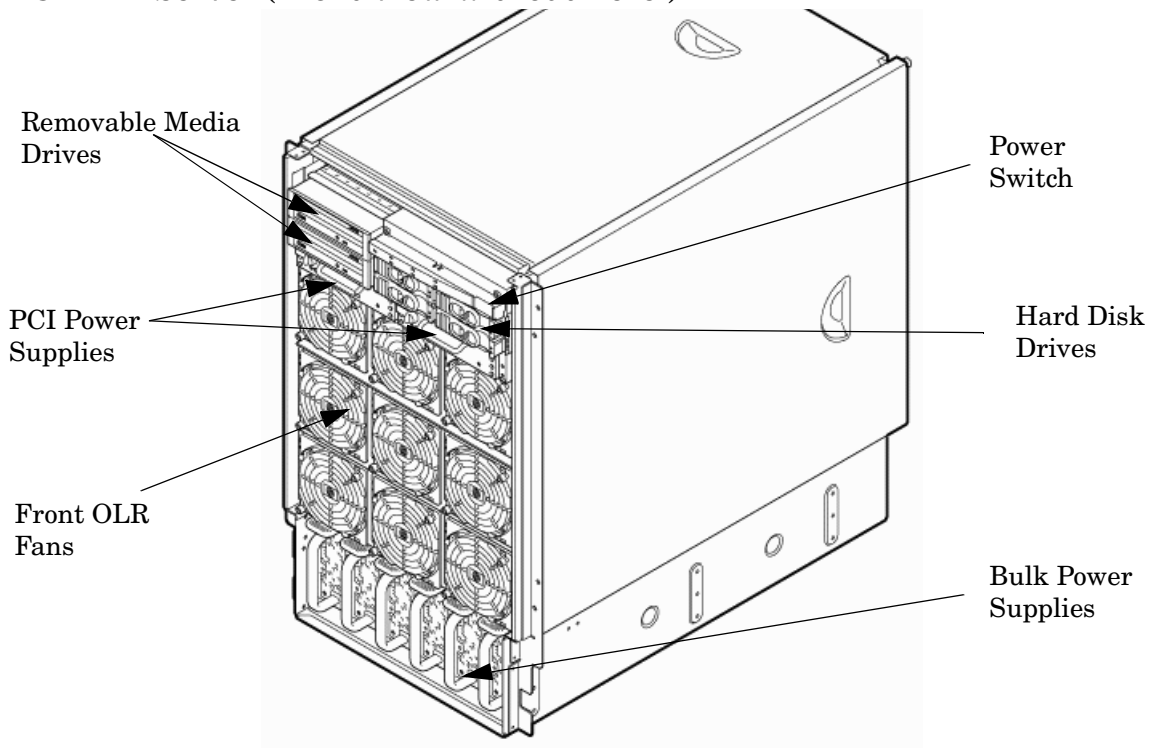

Figure 1-3 Server (Front View Without Bezel)



The server has the following dimensions:

- Depth: Defined by cable management constraints to fit into a standard 36-inch deep rack:
 - 25.5 inches from front rack column to PCI connector surface
 - 26.7 inches from front rack column to core I/O card connector surface
 - 30 inches overall package dimension, including 2.7 inches protruding in front of the front rack columns
- Width: 17.5 inches, constrained by EIA standard 19-inch racks
- Height: 17 U (29.55 inches), constrained by package density

The mass storage section located in the front enables access to removable media drives without removal of the bezel. The mass storage bay accommodates two 5.25-inch removable media drives and up to four 3.5-inch hard disk drives. The front panel display, containing LEDs and the system power switch, is located directly above the hard drive media bays.

Below the mass storage section and behind a removable bezel are two PCI-X power supplies. Each PCI-X power supply powers both I/O partitions. Two PCI-X power supplies offer a N+1 configuration.

Enclosed with protective finger guards are nine front online replace (OLR) fan modules.

The bulk power supply is partitioned by a sealed metallic enclosure located in the bottom of the server. This enclosure houses the N+1 fully redundant bulk power supplies. Install these power supplies from the front of the server after removing the front bezel. The power supply is 2.45 X 5.625 X 20.0 inches.

Figure 1-4 Server (Rear View)

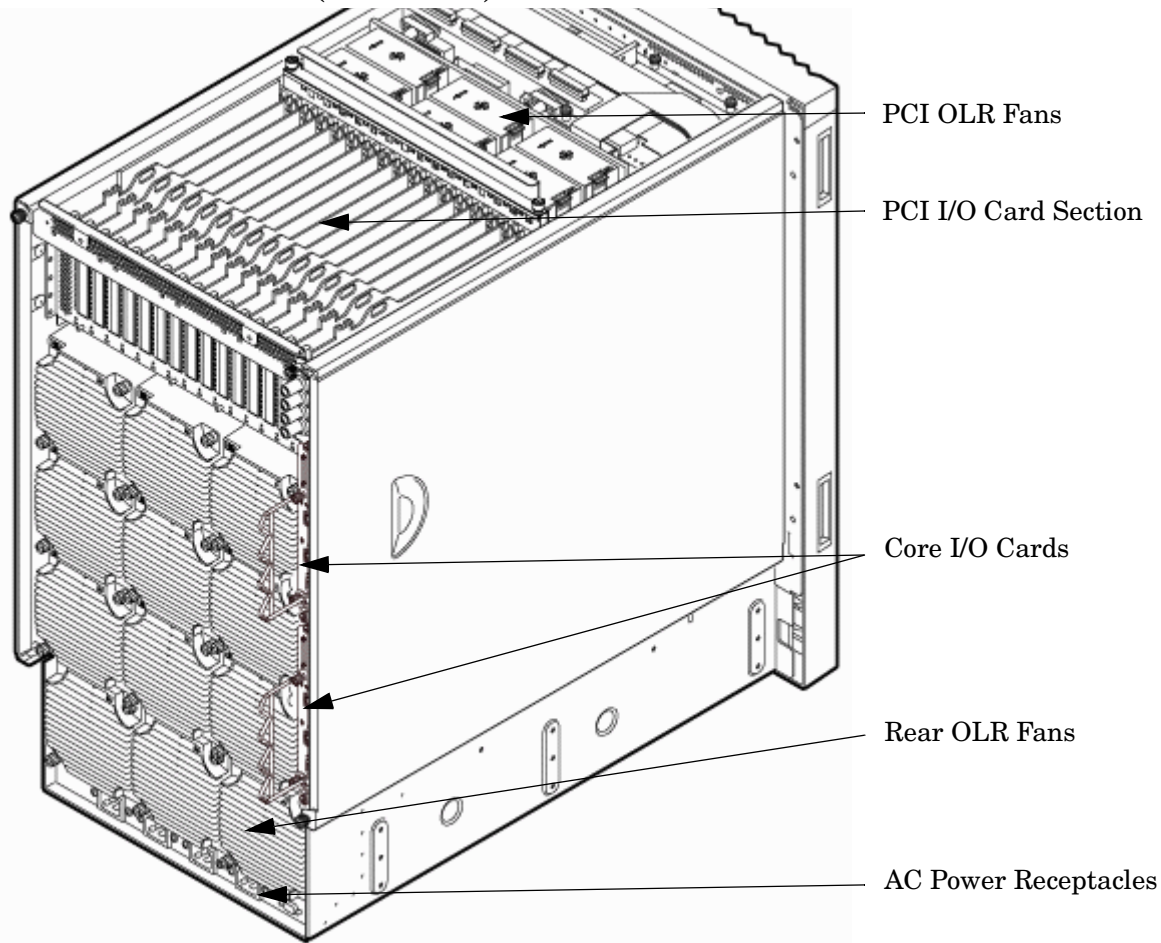

Access the PCI-X I/O card section, located toward the rear by removing the top cover.

The PCI card bulkhead connectors are located at the rear top.

The PCI OLR fan modules are located in front of the PCI cards. They are housed in plastic carriers.

The 12 rear OLR fans attached outside the chassis house 120-mm exhaust fans.

The cell boards are located on the right side of the server behind a removable side cover. For rack mounted servers on slides, the rack front door requires removal *if* it is hinged on the right side of the rack. Removal will allow unrestricted access to server sides after sliding server out for service.

The two redundant core I/O cards are positioned vertically end-to-end at the rear of the chassis.

Redundant line cords attach to the AC power receptacles at the bottom rear. Two 20-amp cords are required to power the server. Two additional line cords provide redundancy.

Access the system backplane by removing the left side cover. The system backplane hinges from the lower edge and is anchored at the top with a single large jack screw assembly.

The SCSI ribbon cable assembly also routes across and fastens to the backside of the system backplane near the connectors that attach the core I/O boards.

The blue deployment handles hinge outward for manual lift. When server is slide mounted, they retract against chassis to enable slide action without obstruction.

Front Panel

Front Panel Indicators and Controls

The front panel, located on the front of the server, includes the power switch. Refer to Figure 1-5.

Enclosure Status LEDs

The following status LEDs are on the front panel:

- Locate LED (blue)
- Power LED (tricolor)
- Management processor (MP) status LED (tricolor)
- Cell 0, 1, 2, 3 status (tricolor) LEDs

Figure 1-5 Front Panel LEDs and Power Switch

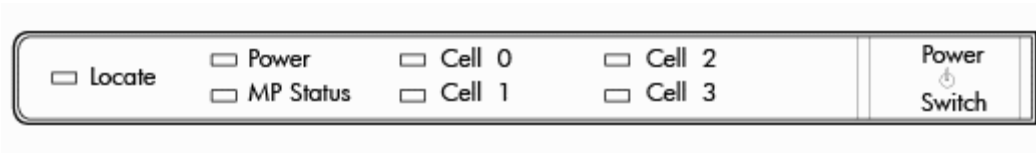

Cell Board

The cell board, illustrated in Figure 1-6, contains the processors, main memory, and the CC application specific integrated circuit (ASIC) which interfaces the processors and memory with the I/O. The CC is the heart of the cell board, providing a crossbar connection that enables communication with other cell boards in the system. It connects to the processor dependent hardware (PDH) and microcontroller hardware. Each cell board holds up to four processor modules and 16 memory DIMMs. One to four cell boards can be installed in the server. A cell board can be selectively powered off for adding processors, memory or maintenance of the cell board, without affecting cells in other configured partitions.

Figure 1-6 Cell Board

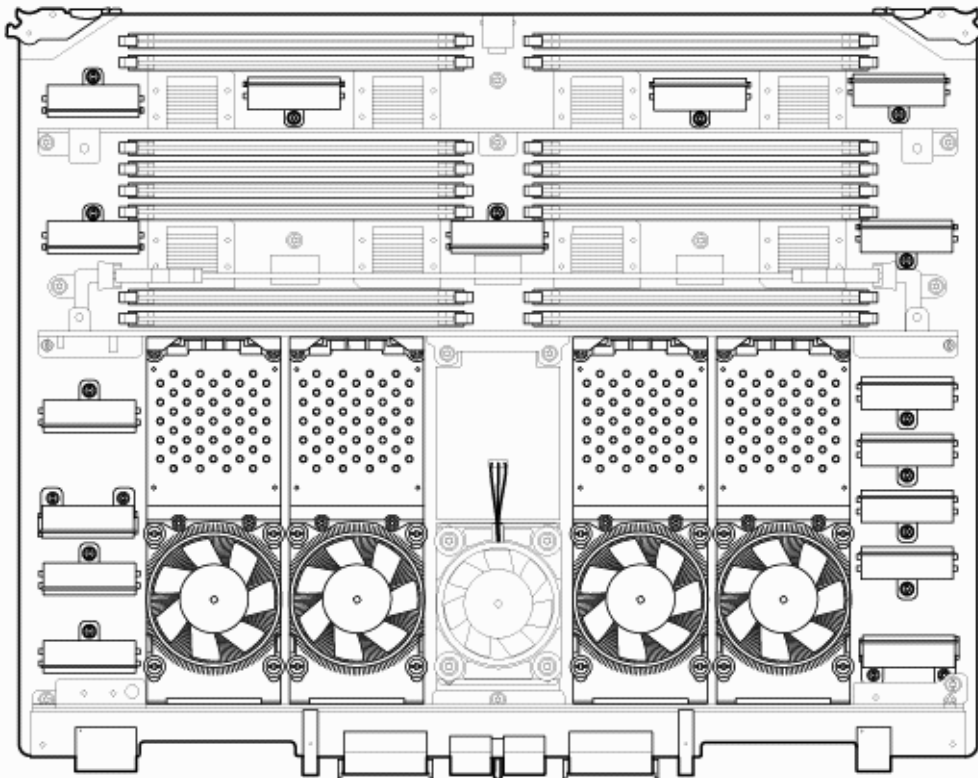

The server has a 48 V distributed power system and receives the 48 V power from the system backplane board. The cell board contains DC-to-DC converters to generate the required voltage rails. The DC-to-DC converters on the cell board do not provide N+1 redundancy.

The cell board contains the following major buses:

- Front side buses (FSB) for each of the four processors
- Four memory buses (one going to each memory quad)
- Incoming and outgoing I/O bus that goes off board to an SBA chip
- Incoming and outgoing crossbar busses that communicate to the crossbar chips on the system backplane
- PDH bus that goes to the PDH and microcontroller circuitry

All of these buses come together at the CC chip.

Because of space limitations on the cell board, the PDH and microcontroller circuitry reside on a riser board that plugs at a right angle into the cell board. The cell board also includes clock circuits, test circuits, and decoupling capacitors.

PDH Riser Board

The server PDH riser board is a small card that plugs into the cell board at a right angle. The PDH riser interface contains the following components:

- Microprocessor memory interface microcircuit
- Hardware including the processor dependant code (PDH) flash memory
- Manageability microcontroller with associated circuitry

The PDH obtains cell board configuration information from cell board signals and from the cell board local power module (LPM).

Central Processor Units

The cell board can hold up to four CPU modules. Each CPU module can contain up to two CPU cores on a single socket. Modules are populated in increments of one. On a cell board, the processor modules must be the same family, type, and clock frequencies. Mixing of different processors on a cell or a partition is not supported. See Table 1-1 on page 29 for the load order that must be maintained when adding processor modules to the cell board. See Figure 1-7 on page 29 for the locations on the cell board for installing processor modules.

NOTE Unlike previous HP cell based systems, the server cell board does not require that a termination module be installed at the end of an unused FSB. System firmware is allowed to disable an unused FSB in the CC. This enables both sockets of the unused bus to remain unpopulated.

Table 1-1 Cell Board CPU Module Load Order

Number of CPU Modules Installed	Socket 2	Socket 3	Socket 1	Socket 0
1	Empty slot	Empty slot	Empty slot	CPU installed
2	CPU installed	Empty slot	Empty slot	CPU installed
3	CPU installed	Empty slot	CPU installed	CPU installed
4	CPU installed	CPU installed	CPU installed	CPU installed

Figure 1-7 Socket Locations on Cell Board

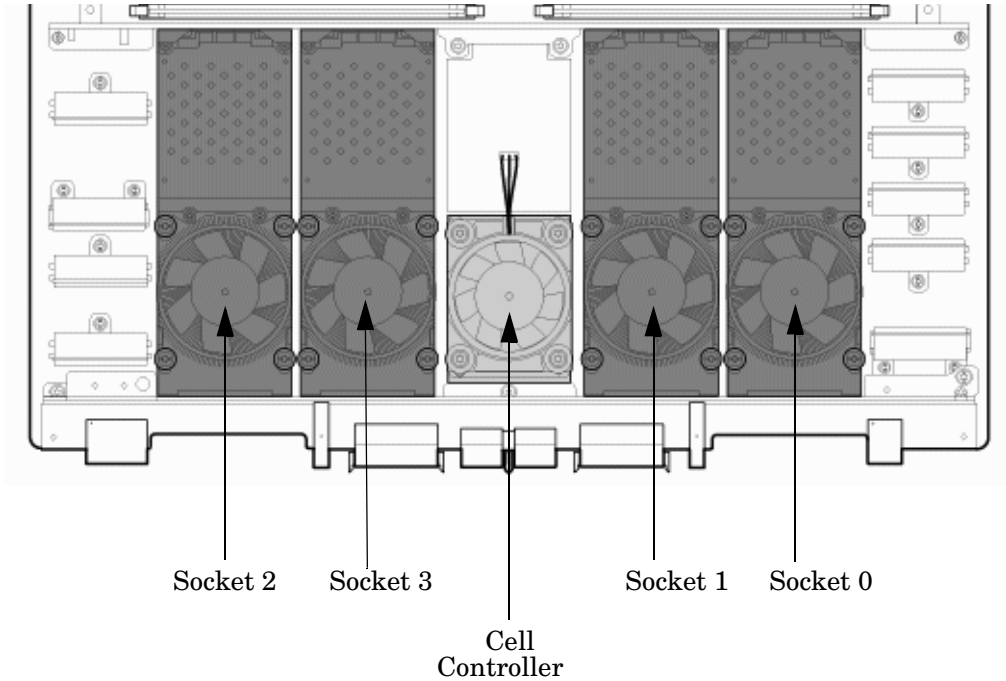

Memory Subsystem

Figure 1-8 on page 30 shows a simplified view of the memory subsystem. It consists of four independent access paths, each path having its own address bus, control bus, data bus, and DIMMs. Address and control signals are fanned out through register ports to the synchronous dynamic random access memory (SDRAM) on the DIMMs.

The memory subsystem comprises four independent quadrants. Each quadrant has its own memory data bus connected from the cell controller to the two buffers for the memory quadrant. Each quadrant also has two memory control buses: one for each buffer.

Figure 1-8 Memory Subsystem

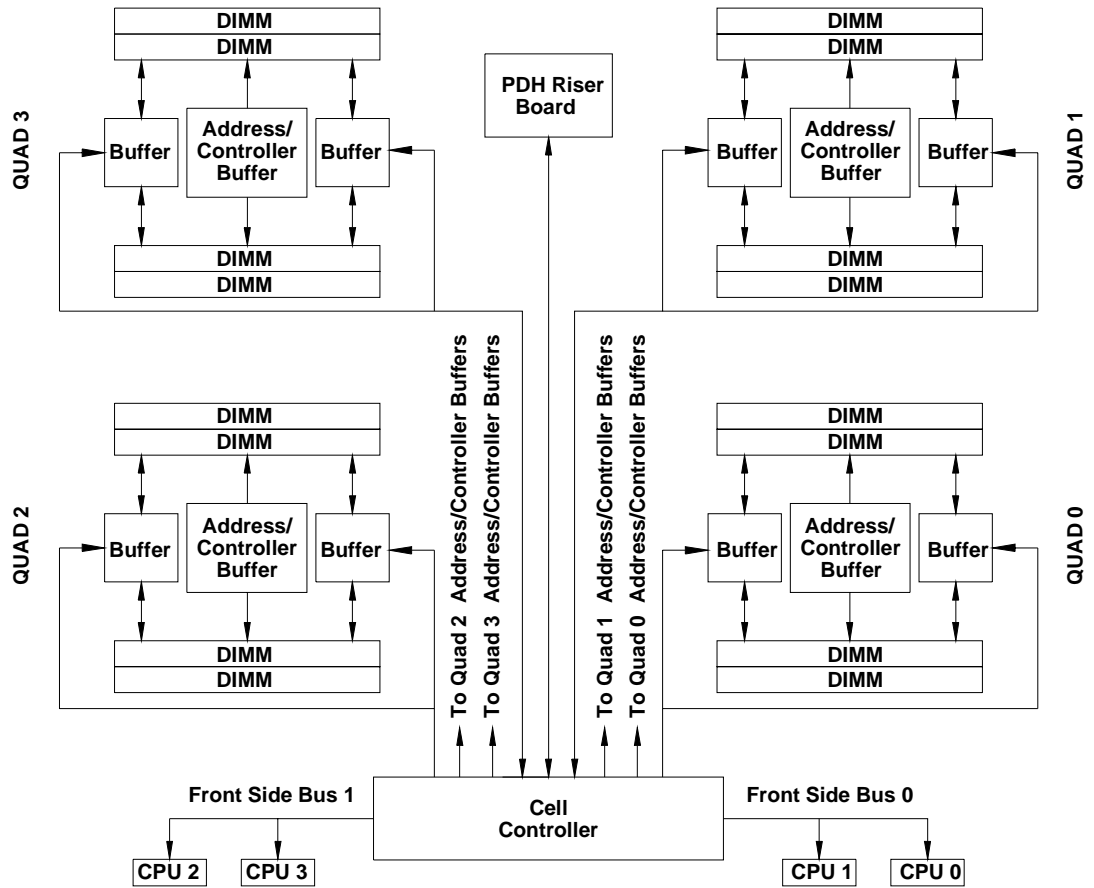

DIMMs

The memory DIMMs used by the server are custom designed by HP. Each DIMM contains DDR-II SDRAM memory that operates at 533 MT/s. Industry standard DIMM modules do not support the high availability and shared memory features of the server. Therefore, industry standard DIMM modules are not supported.

The server supports DIMMs with densities of 1, 2, 4, and 8 GB. Table 1-2 on page 31 lists each supported DIMM size, the resulting total server capacity, and the memory component density. Each DIMM is connected to two buffer chips on the cell board.

Table 1-2 DIMM Sizes Supported

DIMM Size	Total Capacity	Memory Component Density
1 GB	64 GB	256 Mb
2 GB	128 GB	512 Mb
4 GB	256 GB	1024 Mb
8 GB	512 GB	2048 Mb

Valid Memory Configurations

The first cell must have one DIMM pair loaded in slots 0A/0B. The server can support as little as 2 GB of main memory using two 1 GB DIMMs installed on one of the cell boards and as much as 512 GB by filling all 16 DIMM slots on all four cell boards with 8 GB DIMMs.

The following rules explain the memory configuration:

1. DIMMs must be loaded in pairs (same size within a pair).
2. DIMM pairs must be loaded in slot order (0A/0B, 1A/1B, 2A/2B, ...)
3. Largest DIMMs must be loaded first followed by progressively smaller DIMM module sizes.

A paired set of DIMMs is called a rank. DIMMs in a rank must be of the same capacity. See Table 1-3 on page 32 and Figure 1-9 on page 32 for DIMM load order and layout on the cell board.

A quad is a grouping of four DIMMs (Figure 1-9). Configurations with 8 or 16 DIMM slots loaded are recommended. Adding a rank enables a dedicated DDR-II bus on a cell to increase the amount of usable memory bandwidth available. Available memory is proportional to the amount of memory installed.

Table 1-3 DIMM Load Order

Number of DIMMs Installed	Action Taken	DIMM Location on Cell Board	Quad Location
2 DIMMs = 1 rank	Install first	0A and 0B	Quad 2
4 DIMMs = 2 rank	Add second	1A and 1B	Quad 1
6 DIMMs = 3 rank	Add third	2A and 2B	Quad 3
8 DIMMs = 4 rank	Add fourth	3A and 3B	Quad 0
10 DIMMs = 5 rank	Add fifth	4A and 4B	Quad 2
12 DIMMs = 6 rank	Add sixth	5A and 5B	Quad 1
14 DIMMs = 7 rank	Add seventh	6A and 6B	Quad 3
16 DIMMs = 8 rank	Add last	7A and 7B	Quad 0

Figure 1-9 DIMM Slot Layout

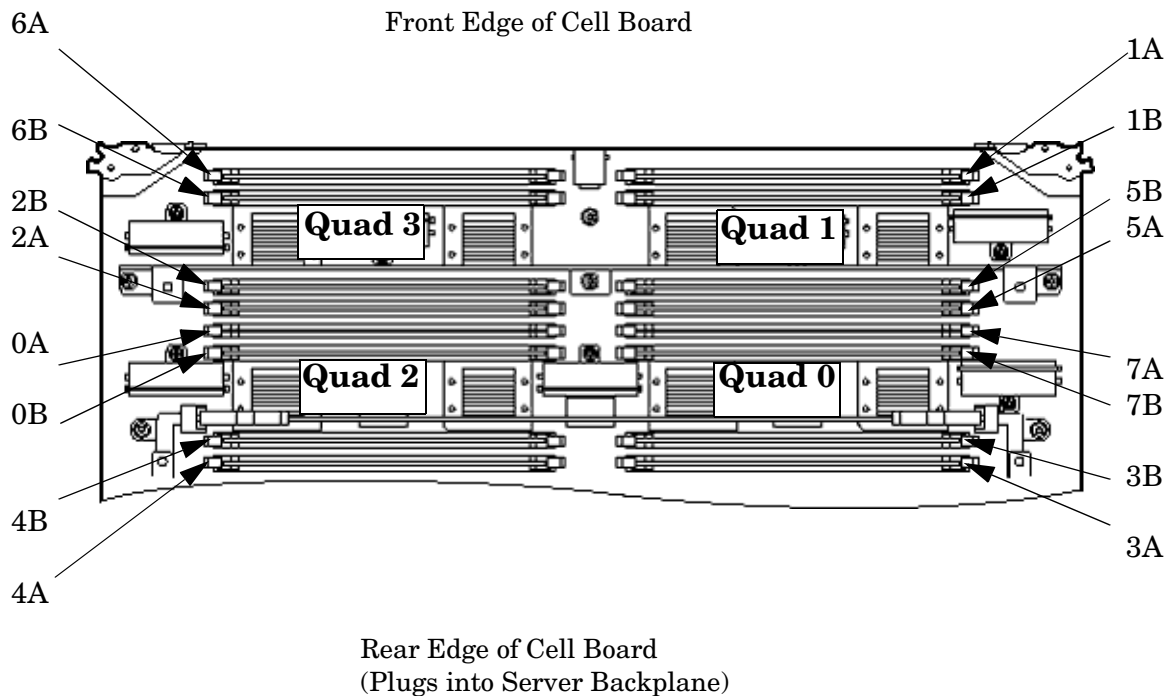

Cells and nPartitions

An nPartition comprises one or more cells working as a single system. Any I/O chassis that is attached to a cell belonging to an nPartition is also assigned to the nPartition. Each I/O chassis has PCI card slots, I/O cards, attached devices, and a core I/O card assigned to the I/O chassis.

Detailed Server Description

On the server, each nPartition has its own dedicated portion of the server hardware which can run a single instance of the operating system. Each nPartition can boot, reboot, and operate independently of any other nPartitions and hardware within the same server complex.

The server complex includes all hardware within an nPartition server: all cabinets, cells, I/O chassis, I/O devices and racks, management and interconnecting hardware, power supplies, and fans.

A server complex can contain one or more nPartitions, enabling the hardware to function as a single system or as multiple systems.

NOTE Partition configuration information is available on the Web at:

<http://docs.hp.com>

Refer to *HP System Partitions Guide: Administration for nPartitions* for details.

Internal Disk Devices

Figure 1-10 shows the top internal disk drives connect to cell 0 through the core I/O for cell 0, in a server cabinet. The bottom internal disk drives connect to cell 1 through the core I/O for cell 1.

The upper removable media drive connects to cell 0 through the core I/O card for cell 0 and the lower removable media drive connects to cell 1 through the core I/O card for cell 1.

A list of replacement disk drives for the server is in Appendix A. The list contains both removable media disk drives and hard disk drives.

Figure 1-10 Internal Disks Locations

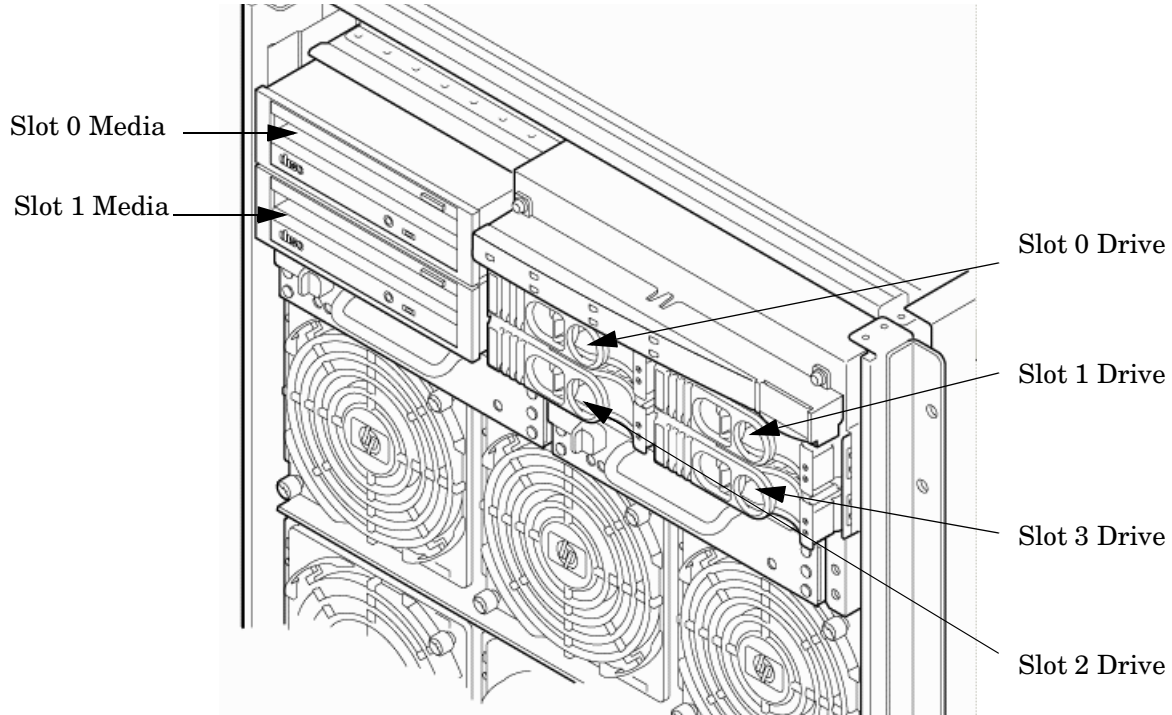

Table 1-4 Removable Media Drive Path

Removable Media	Path
Slot 0 media	0/0/0/2/1.x ^a .0
Slot 1 media	1/0/0/2/1.x ^a .0

a. X equals 2 for a DVD drive while X equals 3 for a DDS-4 DAT drive.

Table 1-5 Hard Disk Drive Path

Hard Drive	Path
Slot 0 drive	0/0/0/2/0.6.0
Slot 1 drive	0/0/0/3/0.6.0

Table 1-5 Hard Disk Drive Path (Continued)

Hard Drive	Path
Slot 2 drive	1/0/0/2/0.6.0
Slot 3 drive	1/0/0/3/0.6.0

System Backplane

The system backplane board contains the following components:

- Two crossbar chips (XBC)
- Clock generation logic
- Preset generation logic
- Power regulators
- Two local bus adapter (LBA) chips that create internal PCI buses for communicating with the core I/O card.

The backplane also contains connectors for attaching the cell boards, PCI-X backplane, MP core I/O cards SCSI cables, bulk power, chassis fans, front panel display, intrusion switches, and external system bus adapters (SBA) link connectors.

Figure 1-11 System Backplane Block Diagram

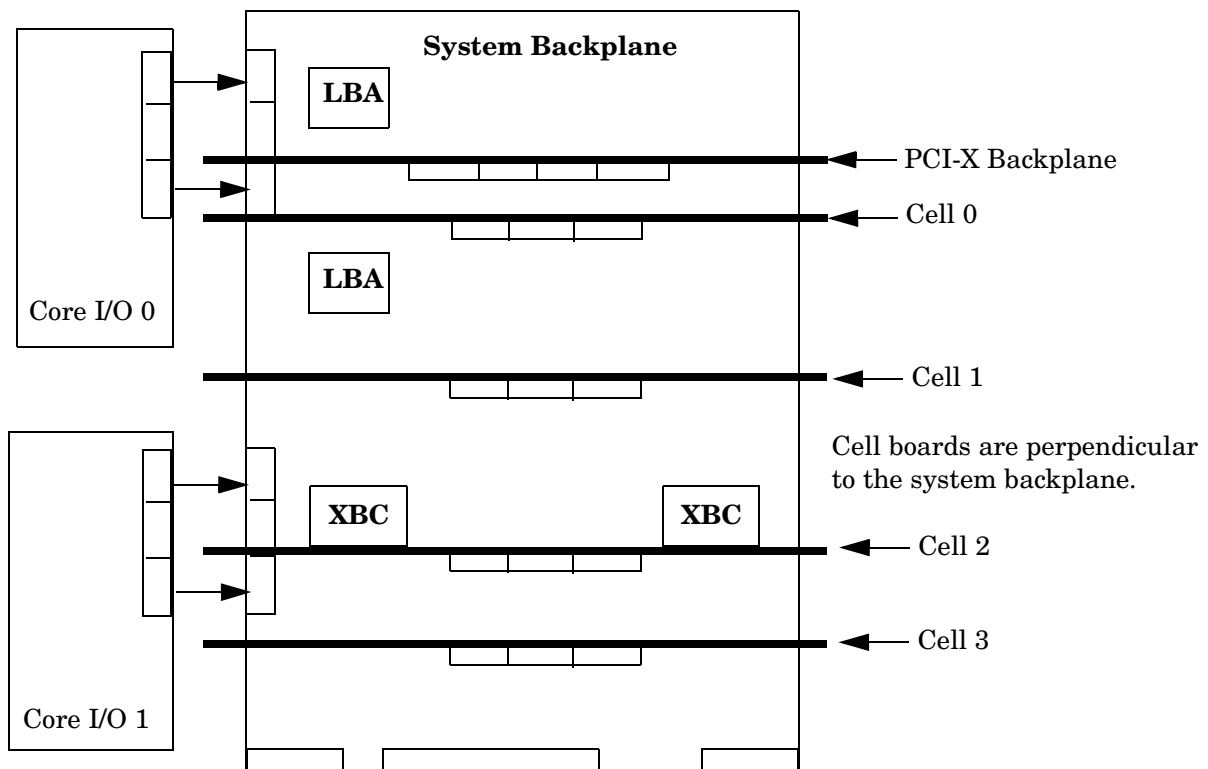

The two LBA PCI bus controllers on the system backplane create the PCI bus for the core I/O cards. You must shut down the partition for the core I/O card before removing the card.

Having the SCSI connectors on the system backplane allows replacement of the core I/O card without having to remove cables in the process.

System Backplane to Cell Board Connectivity

The system backplane provides four sets of connectors, one set for each cell board.

The system backplane routes the signals from the cell boards to the communication crossbars. Cell boards 0 and 1 are directly connected to the I/O backplane found in the server. Cell boards 2 and 3 can be connected to a separate I/O expansion chassis connected to the system backplane.

System Backplane to Core I/O Card Connectivity

The core I/O cards connect to the system backplane through two connectors found at the rear of the system. SCSI and LAN on a core I/O are accessed via a PCI-X 66 MHz bus. Two LBA bus controllers located on the system backplane allow communication to the I/O devices. The LBAs are connected to the SBA on the PCI-X backplane by single ropes.

The system backplane routes the signals to the various components in the system. The core I/O signals include the SCSI bus for the system hard drives and the bus for the removable media devices. Each core I/O card provides SCSI buses for the mass storage devices.

The management processor for the chassis resides on the core I/O card, so the system backplane also provides interfaces required for management of the system. These interfaces and the manageability circuitry run on standby power.

You can remove the core I/O cards from the system as long as you shut down the partition for the core I/O card before removing the card. The hot-plug circuitry that enables this feature is located on the system backplane near the core I/O sockets.

System Backplane to PCI-X Backplane Connectivity

The PCI-X backplane uses two connectors for the SBA link bus and two connectors for the high-speed data signals and the manageability signals.

SBA link bus signals are routed through the system backplane to the cell controller on each corresponding cell board.

The high-speed data signals are routed from the SBA chips on the PCI-X backplane to the two LBA PCI bus controllers on the system backplane.

Clocks and Reset

The system backplane contains reset and clock circuitry that propagates through the whole system. The system backplane central clocks drive all major chip set clocks. The system central clock circuitry features redundant, hot-swappable oscillators.

I/O Subsystem

The cell board to the PCI-X board path runs from the CC to the SBA, from the SBA to the ropes, from the ropes to the LBA, and from the LBA to the PCI slots as shown in Figure 1-12 on page 38. The CC on cell board 0 and cell board 1 communicates through an SBA over the SBA link. The SBA link consists of both an inbound and an outbound link with a peak bandwidth of approximately 11.5 GB/s at 3.2 GT/s. The SBA converts the

SBA link protocol into “ropes.” A rope is defined as a high-speed, point-to-point data bus. The SBA can support up to 16 of these high-speed bidirectional rope links for a total aggregate bandwidth of approximately 11.5 GB/s.

There are LBA chips on the PCI-X backplane that act as a bus bridge, supporting either one or two ropes for PCI-X 133 MHz slots and the equivalent bandwidth of four ropes for PCI-X 266 MHz slots. Each LBA acts as a bus bridge, supporting one or two ropes and capable of driving 33 MHz or 66 MHz for PCI cards. The LBAs can also drive at 66 MHz or 133 MHz for PCI-X mode 1 cards, and at 266 MHz for PCI-X mode 2 cards installed in mode 2 capable slots. When cell board 2 and cell board 3 are present, the cell boards attach to their own associated SBA and LBA chips on the PCI-X board in the Server Expansion Unit.

Figure 1-12 PCI-X Board to Cell Board Block Diagram

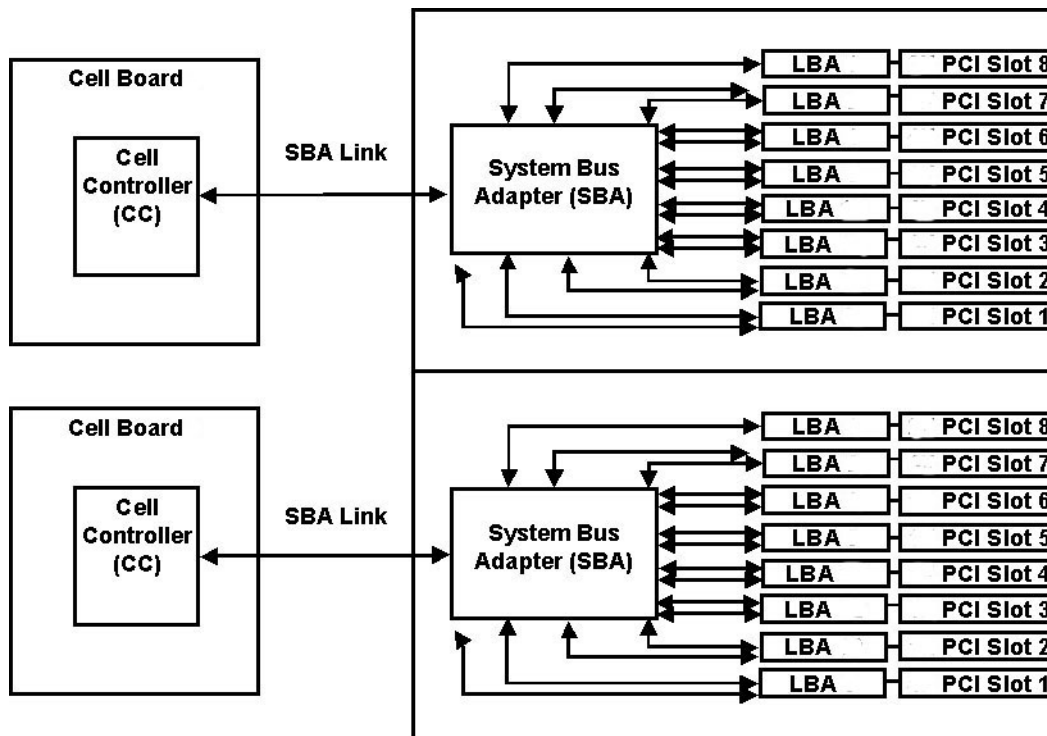

Table 1-6 and Table 1-7 on page 39 list the mapping of PCI-X slots to boot paths. The cell column refers to the cell boards installed in the server.

Table 1-6 PCI-X Slot Boot Paths Cell 0

Cell	PCI Slot	Ropes	Path
0	1	8/9	0/0/8/1/0
0	2	10/11	0/0/10/1/0
0	3	12/13	0/0/12/1/0
0	4	14/15	0/0/14/1/0
0	5	6/7	0/0/6/1/0
0	6	4/5	0/0/4/1/0

Table 1-6 PCI-X Slot Boot Paths Cell 0 (Continued)

Cell	PCI Slot	Ropes	Path
0	7	2/3	0/0/2/1/0
0	8	1	0/0/1/1/0

Table 1-7 PCI-X Slot Boot Paths Cell 1

Cell	PCI Slot	Ropes	Path
1	1	8/9	1/0/8/1/0
1	2	10/11	1/0/10/1/0
1	3	12/13	1/0/12/1/0
1	4	14/15	1/0/14/1/0
1	5	6/7	1/0/6/1/0
1	6	4/5	1/0/4/1/0
1	7	2/3	1/0/2/1/0
1	8	1	1/0/1/1/0

The server supports two internal SBAs. Each SBA provides the control and interfaces for eight PCI-X slots. The interface is through the rope bus (16 ropes per SBA). For each SBA, the ropes are divided in the following manner:

- A single rope is routed to support the core I/O boards through LBAs located on the system backplane.
- A single rope is routed to an LBA on the PCI backplane to support a slot for PCI and PCI-X cards (slot 8).
- Six ropes are bundled into double ropes to three (3) LBAs. They support slots 1, 2, and 7 for PCI and PCI-X mode 1 cards.
- Eight fat ropes are bundled into quad ropes to four (4) LBAs. They support slots 3, 4, 5, and 6 for PCI and PCI-X mode 2 cards.

NOTE PCI-X slots 1-7 are dual rope slots while slot 8 is a single rope slot. A rope is defined as a high-speed, point-to-point data bus.

Each of the 16 slots is capable of 33 MHz/66 MHz PCI or 66 MHz/133 MHz PCI-X. Four slots in PCI-X support 266 MHz. All 16 PCI slots are keyed for 3.3 V connectors (accepting both Universal and 3.3 V cards). The PCI-X backplane does not provide any 5 V slots for the I/O cards. Table 1-8 on page 40 summarizes the PCI-X slot types.

The PCI-X backplane is physically one board, yet it behaves like two independent partitions. SBA 0 and its associated LBAs and eight PCI-X slots form one I/O partition. SBA 1 and its associated LBAs and eight PCI-X slots form the other I/O partition. One I/O partition can be reset separately from the other I/O partition but cannot be powered down independently.

IMPORTANT Always refer to the PCI card's manufacturer for the specific PCI card performance specifications. PCI, PCI-X mode 1, and PCI-X mode 2 cards are supported at different clock speeds. Select the appropriate PCI-X I/O slot for best performance.

Table 1-8 PCI-X Slot Types

I/O Partition	Slot ^a	Maximum MHz	Maximum Peak Bandwidth	Ropes	Supported Cards	PCI Mode Supported
0	8	133	533 MB/s	001	3.3 V	PCI or PCI-X Mode 1
	7	133	1.06 GB/s	002/003	3.3 V	PCI or PCI-X Mode 1
	6	266	2.13 GB/s	004/005	3.3 V or 1.5 V	PCI-X Mode 2
	5	266	2.13 GB/s	006/007	3.3 V or 1.5 V	PCI-X Mode 2
	4	266	2.13 GB/s	014/015	3.3 V or 1.5 V	PCI-X Mode 2
	3	266	2.13 GB/s	012/013	3.3 V or 1.5 V	PCI-X Mode 2
	2	133	1.06 GB/s	010/011	3.3 V	PCI or PCI-X Mode 1
	1	133	1.06 GB/s	008/009	3.3 V	PCI or PCI-X Mode 1
1	8	133	533 MB/s	001	3.3 V	PCI or PCI-X Mode 1
	7	133	1.06 GB/s	002/003	3.3 V	PCI or PCI-X Mode 1
	6	266	2.13 GB/s	004/005	3.3 V or 1.5 V	PCI-X Mode 2
	5	266	2.13 GB/s	006/007	3.3 V or 1.5 V	PCI-X Mode 2
	4	266	2.13 GB/s	014/015	3.3 V or 1.5 V	PCI-X Mode 2
	3	266	2.13 GB/s	012/013	3.3 V or 1.5 V	PCI-X Mode 2
	2	133	1.06 GB/s	010/011	3.3 V	PCI or PCI-X Mode 1
	1	133	1.06 GB/s	008/009	3.3 V	PCI or PCI-X Mode 1

a. Each slot will auto select the proper speed for the card installed up to the maximum speed for the slot. Placing high speed cards into slow speed slots will cause the card to be driven at the slow speed.

Core I/O Card

Up to two core I/O cards can be plugged into the server. Two core I/O cards enable two I/O partitions to exist in the server. The server can have up to two partitions. When a Server Expansion Unit with two core I/O cards is attached to the server, two additional partitions can be configured.

A core I/O card can be replaced with standby power applied. The system power to the core I/O is handled in the hardware the same way a hot-plug PCI/PCI-X card is handled. Standby power to core I/O is handled by power manager devices to limit inrush current during insertion.

Mass Storage (Disk) Backplane

Internal mass storage connections to disks are routed on the mass storage backplane, which has connectors and termination logic. All hard disks are hot-plug but removable media disks are not hot-plug. The server accommodates two internal, removable media devices. Power connectors for removable media devices are on the mass storage backplane. For more information, refer to Figure 1-13.

Figure 1-13 Mass Storage Block Diagram

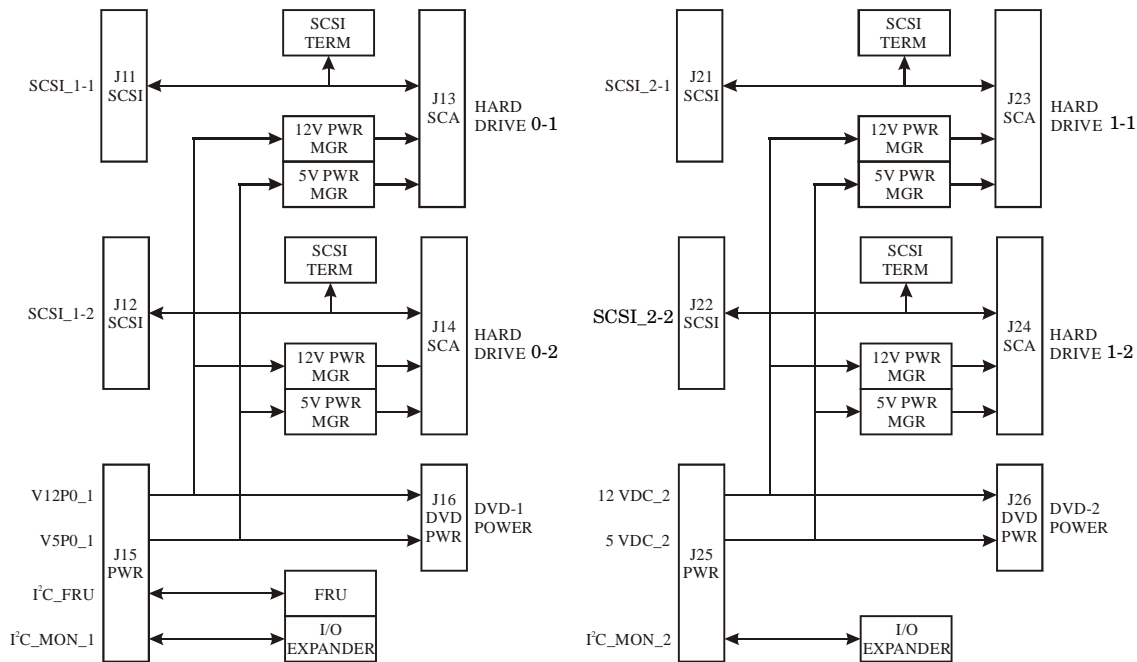

2 System Specifications

This chapter describes the basic system configuration, physical specifications and requirements for the server.

Dimensions and Weights

This section provides dimensions and weights of the server and server components. Table 2-1 gives the dimensions and weights for a fully configured server.

Table 2-1 Server Dimensions and Weights

	Standalone	Packaged
Height - Inches (centimeters)	29.55 (75.00)	86.50 (219.70)
Width - Inches (centimeters)	17.50 (44.50)	40.00 (101.60)
Depth - Inches (centimeters)	30.00 (76.20)	48.00 (122.00)
Weight - Pounds (kilograms)	368.00 ^a (166.92)	813.00 ^b (368.77)

- a. This weight represents a fully configured server before it is installed in a rack.
- b. The packaged weight represents a server installed in a 2-m rack. The packaged weight includes a fully configured server in a 2-m rack with a rear door, rail slide kit, line cord anchor kit, interlock assembly, cable management arm, 120-lb ballast kit, and a 60-A PDU. The shipping box, pallet, and container, not included in the packaged weight in Table 2-1, adds approximately 150.0-lb to the total system weight when shipped. The size and number of miscellaneous pallets will be determined by the equipment ordered by the customer.

Table 2-2 provides component weights for calculating the weight of a server not fully configured. Table 2-3 on page 44 provides an example of how to calculate the weight. Table 2-4 on page 44 is a blank worksheet for calculating the weight of the server. To determine the overall weight, follow the example in Table 2-3, and complete the worksheet in Table 2-4 for your system.

Table 2-2 Server Component Weights

Quantity	Description	Weight lb (kg)
1	Chassis	131.00 (59.42)
1	System backplane	20.0 (9.07)
1	PCI-X card cage assembly	20.40 (9.25)
2	PCI-X power supply	5.00 (2.27) each
6	Bulk power supply	12.00 (5.44) each
1	Mass storage backplane	1.00 (0.45)
1 - 4	Cell board	27.80 (12.61) each
1 - 4	Hard disk drive	1.60 (0.73) each
1 - 2	Removable media disk drive	2.20 (1.00) each

Table 2-3 Example Weight Summary

Component	Quantity	Multiply	Weight (kg)
Cell board	4	27.8 lb 12.16 kg	107.20 lb 48.64 kg
PCI card (varies - used sample value)	4	0.34 lb 0.153 kg	1.36 lb 0.61 kg
Power supply (BPS)	6	12 lb 5.44 kg	72 lb 32.66 kg
DVD drive	2	2.2 lb 1.0 kg	4.4 lb 2.0 kg
Hard disk drive	4	1.6 lb 0.73 kg	6.40 lb 2.90 kg
Chassis with skins and front bezel cover	1	131 lb 59.42 kg	131 lb 59.42 kg
		Total weight	322.36 lb 146.22 kg

Table 2-4 Weight Summary

Component	Quantity	Multiply By	Weight (kg)
Cell Board		27.8 lb 12.16 kg	lb kg
PCI Card		varies lb varies kg	lb kg
Power Supply (BPS)		12 lb 5.44 kg	lb kg
DVD Drive		2.2 lb 1.0 kg	lb kg
Hard Disk Drive		1.6 lb 0.73 kg	lb kg
Chassis with skins and front bezel cover		131 lb 59.42 kg	lb kg
		Total weight	lb kg

Electrical Specifications

This section provides electrical specifications for HP Integrity rx8640 and HP 9000 rp8440 servers. These servers share common specifications. The exceptions are separate system power as well as power dissipation and cooling requirements. The associated data can be found in Table 2-7 on page 47, Table 2-8 on page 48, Table 2-10 on page 52 and Table 2-11 on page 53.

Grounding

The site building shall provide a safety ground and protective earth for each AC service entrance to all cabinets.

Install a protective earthing (PE) conductor that is identical in size, insulation material, and thickness to the branch-circuit supply conductors. The PE conductor must be green with yellow stripes. The earthing conductor described is to be connected from the unit to the building installation earth or if supplied by a separately derived system, at the supply transformer or motor-generator set grounding point.

Circuit Breaker

The Marked Electrical for the server is 15 amps per line cord. The recommended circuit breaker size is 20 amps for North America. For countries outside North America, consult your local electrical authority having jurisdiction for the recommended circuit breaker size.

The server contains four C20 power receptacles located at the bottom rear bulkhead. A minimum of two power cords must be used to maintain normal operation of the server. A second set of two cords can be added to improve system availability by protecting, for example, against power source failures or accidentally tripped circuit breakers. The server can receive AC input from two different AC power sources.

System AC Power Specifications

Power Cords

Table 2-5 lists the various power cables available for use with the server. Each power cord is 15 feet (4.5-m) in length with a IEC 60320-1 C19 female connector attached to one end.

Table 2-5 **Power Cords**

Part Number	Description	Where Used
8120-6895	Stripped end, 240 volt	International - Other
8120-6897	Male IEC309, 240 volt	International
8121-0070	Male GB-1002, 240 volt	China
8120-6903	Male NEMA L6-20, 240 volt	North America/Japan

System Power Specifications

Table 2-6 lists the AC power requirements for the servers. This table provides information to help determine the amount of AC power needed for your computer room.

Table 2-6 HP Integrity rx8640 and HP 9000 rp8440 AC Power Requirements

Requirements	Value	Comments
Nominal input voltage	200–240 VAC	
Minimum operating voltage	180 VAC	
Maximum operating voltage	269 VAC	
Frequency range (minimum - maximum)	50/60 Hz	
Number of phases	1	
Rated line current	15 A	Per line cord
Maximum inrush current	54 A peak for 20 ms	Per line cord
Dropout carry-through time at minimum line voltage	20 ms	
Circuit breaker rating	20A	Per line cord
Power factor correction	>0.98 >0.95	At all loads of 50%–100% of supply rating At all loads of 25%–50% of supply rating
Ground leakage current (mA)	<3.0 (ma)	Per line cord

Table 2-7 HP Integrity rx8640 System Power Requirements

Power Required (50–60 Hz)	Watts	VA	Comments
Maximum Theoretical Power	5862	5982	See Note 1
Marked Electrical Power	— — —	5400	30A @ 180 VAC, See Note 2
User Expected Maximum Power	3883	3962	See Note 3

Note 1: Maximum Theoretical Power: or “Maximum Configuration” (Input power at the ac input expressed in Watts and Volt-Amps to take into account Power factor correction.)

The calculated sum of the maximum worst case power consumption for every subsystem in the server. This number will never be exceeded by a functioning server for any combination of hardware and software under any conditions.

Note 2: Marked Electrical Power: (Input power at the ac input expressed in Volt-Amps.)

The Marked Electrical Power is the rating given on the chassis label and represents the input power required for facility ac power planning and wiring requirements. This number represents the expected maximum power consumption for the server based on the power rating of the bulk power supplies. This number can safely be used to size ac circuits and breakers for the system under all conditions.

Note 3: User Expected Maximum Power: (Input power at the ac input expressed in Watts and Volt-Amps.)

The measured maximum worst case power consumption. This number represents the largest power consumption that HP engineers were able to produce for the server with any combination of hardware under laboratory conditions using aggressive software applications designed specifically to work the system at maximum load. This number can safely be used to compute thermal loads and power consumption for the system under all conditions.

Table 2-8 HP 9000 rp 8440 System Power Requirements

Power Required (50–60 Hz)	Watts	VA	Comments
Maximum Theoretical Power	5720	5837	See Note 1
Marked Electrical Power	---	5400	30A @ 180 VAC, See Note 2
User Expected Maximum Power	3789	3866	See Note 3

Note 1: Maximum Theoretical Power: or “Maximum Configuration” (Input power at the ac input expressed in Watts and Volt-Amps to take into account Power factor correction.)

The calculated sum of the maximum worst case power consumption for every subsystem in the server. This number will never be exceeded by a functioning server for any combination of hardware and software under any conditions.

Note 2: Marked Electrical Power: (Input power at the ac input expressed in Volt-Amps.)

The Marked Electrical Power is the rating given on the chassis label and represents the input power required for facility ac power planning and wiring requirements. This number represents the expected maximum power consumption for the server based on the power rating of the bulk power supplies. This number can safely be used to size ac circuits and breakers for the system under all conditions.

Note 3: User Expected Maximum Power: (Input power at the ac input expressed in Watts and Volt-Amps.)

The measured maximum worst case power consumption. This number represents the largest power consumption that HP engineers were able to produce for the server with any combination of hardware under laboratory conditions using aggressive software applications designed specifically to work the system at maximum load. This number can safely be used to compute thermal loads and power consumption for the system under all conditions.

Environmental Specifications

This section provides the environmental, power dissipation, noise emission, and air flow specifications for the server.

Temperature and Humidity

The cabinet is actively cooled using forced convection in a Class C1-modified environment. The recommended humidity level for Class C1 is 40 to 55% relative humidity (RH).

Operating Environment

The system is designed to run continuously and meet reliability goals in an ambient temperature of 5° C–32° C at sea level. The maximum allowable temperature is derated 1° C per 1,000 feet of elevation above 3,000 feet above sea level up to 25° C at 10,000 feet. For optimum reliability and performance, the recommended operating range is 20° C to 25° C. This meets or exceeds the requirements for Class 2 in the corporate and ASHRAE standard. See Table 2-9 on page 50 for an example of the ASHRAE thermal report.

Table 2-9 Example ASHRAE Thermal Report

	Condition						
	Voltage 208 Volts			Weight		Over System Dimensions (W x D x H)	
	Typical Heat Release	Airflow, nominal	Airflow, maximum at 32° C				
Description	Watts	cfm	(m ³ /hr)	lb	kg	Inches	mm
Minimum configuration	971	960	1631	178	81	h=29.55 w=17.50 d=30.00	750.57 444.50 762.00
Full configuration	3883	960	1631	370	168	h=29.55 w=17.50 d=30.00	750.57 444.50 762.00
Typical configuration	2380	960	1631	286	130	h=29.55 w=17.50 d=30.00	750.57 444.50 762.00
ASHRAE class			Minimum configuration	1 cell board, 2 CPUs, 2 GB, 1 core I/O card			
			Full configuration	4 cell boards, 16 CPUs, 128 GB, 2 core I/O cards, 16 I/O cards, 4 hard disks			
			Typical configuration	2 cell boards, 8 CPUs, 64 GB, 1 core I/O card, 8 I/O cards, 2 hard disks			

Environmental Temperature Sensor

To ensure that the system is operating within the published limits, the ambient operating temperature is measured using a sensor placed on the server backplane. Data from the sensor is used to control the fan speed and to initiate system overtemp shutdown.

Non-Operating Environment

The system is designed to withstand ambient temperatures between -40° C to 70° C under non-operating conditions.

Cooling

Internal Chassis Cooling

The cabinet incorporates front-to-back airflow across the system backplane. Nine 120-mm fans mounted externally on the front chassis wall behind the cosmetic front bezel push air into the unit. Twelve 120-mm fans housed in cosmetic plastic fan carriers and mounted externally to the rear chassis wall pull air through the unit.

Each fan is controlled by a smart fan control board embedded in the fan module plastic housing. The smart fan control board receives fan control input from the system fan controller on the system backplane and returns fan status information to the system fan controller. The smart fan control board also controls the power and the pulse width modulated control signal to the fan and monitors the speed indicator back from the fan. The fan status LED is driven by the smart fan control board.

Bulk Power Supply Cooling

Cooling for the bulk power supplies (BPS) is provided by two 60mm fans contained within each BPS. Air flows into the front of the BPS and is exhausted out of the top of the power supply through upward facing vents near the rear of the supply. The air is then ducted out of the rear of the chassis.

PCI/Mass Storage Section Cooling

Six 92mm fans located between the mass storage devices and the PCI card cage provide airflow through these devices. The PCI fans are powered off of housekeeping power and run at full speed at all times. The air is pulled through the mass storage devices and pushed through the PCI card cage. Separation is provided between the PCI bulkheads to allow adequate exhaust ventilation and to help reduce the localized airflow dead spots that typically occur at the faceplate tail of each PCI card.

Standby Cooling

Several components within the chassis consume significant amounts of power while the system is in standby mode. The system fans will run at a portion of full speed during standby to remove the resulting heat from the cabinet. The fans within the power supply will operate at full speed during standby.

Typical HP Integrity rx8640 Power Dissipation and Cooling

Table 2-10 provides calculations for rx8640 configurations as described in the table.

Table 2-10 Typical HP Integrity rx8640 Server Configurations

Cell Board w/4P	Memory per Cell Board	PCI Cards (assumes 10W each)	DVDs	Hard Disk Drives	Core I/O	Bulk Power Supplies	Typical Power	Typical Cooling
Qty	GBytes	Qty	Qty	Qty	Qty	Qty	Watts	BTU/hr
4	32	16	2	4	2	6	3883	13257
4	16	16	2	4	2	6	3627	12383
4	8	8	0	2	2	6	3419	11672
2	32	16	2	4	2	4	2749	9385
2	16	8	0	2	2	4	2461	8402
2	8	8	0	2	2	4	2397	8183
1	8	8	0	1	1	3	1893	6463

The air-conditioning data in Table 2-10 are derived using the following equations.

- Watts x (0.860) = kcal/hour
- Watts x (3.414) = Btu/hour
- BTU/hour divided by 12,000 = tons of refrigeration required

NOTE When determining power requirements, you must consider any peripheral equipment that will be installed during initial installation or as a later update. Refer to the applicable documentation for such devices to determine the power and air-conditioning that is required to support these devices.

Typical HP 9000 rp8440 Power Dissipation and Cooling

Table 2-11 provides calculations for the rp8440 configurations as described in the table.

Table 2-11 Typical HP 9000 rp8440 Server Configurations

Cell Board w/4P	Memory per Cell Board	PCI Cards (assumes 10W each)	DVDs	Hard Disk Drives	Core I/O	Bulk Power Supplies	Typical Power	Typical Cooling
Qty	GBytes	Qty	Qty	Qty	Qty	Qty	Watts	BTU/hr
4	32	16	2	4	2	6	3789	12936
4	16	16	2	4	2	6	3533	12062
4	8	8	0	2	2	6	3325	11352
2	32	16	2	4	2	4	2702	9225
2	16	8	0	2	2	4	2414	8241
2	8	8	0	2	2	4	2350	8023
1	8	8	0	1	1	3	1893	6463

The air-conditioning data in Table 2-11 are derived using the following equations.

- Watts x (0.860) = kcal/hour
- Watts x (3.414) = Btu/hour
- BTU/hour divided by 12,000 = tons of refrigeration required

NOTE When determining power requirements, you must consider any peripheral equipment that will be installed during initial installation or as a later update. Refer to the applicable documentation for such devices to determine the power and air-conditioning that is required to support these devices.

Acoustic Noise Specification

The acoustic noise specification for the servers is 55.6 db (sound pressure level at bystander position). It is appropriate for dedicated computer room environments, not office environments. The LwA is 7.4 Bels. Care should be taken to understand the acoustic noise specifications relative to operator positions within the computer room or when adding servers to computer rooms with existing noise sources.

Air Flow

The recommended server cabinet air intake temperature is between 20°C and 25°C (68° F and 77° F) at 960 CFM.

Figure 2-1 illustrates the location of the inlet and outlet airducts on a single cabinet. Air is drawn into the front of the server and forced out the rear.

Figure 2-1 Airflow Diagram

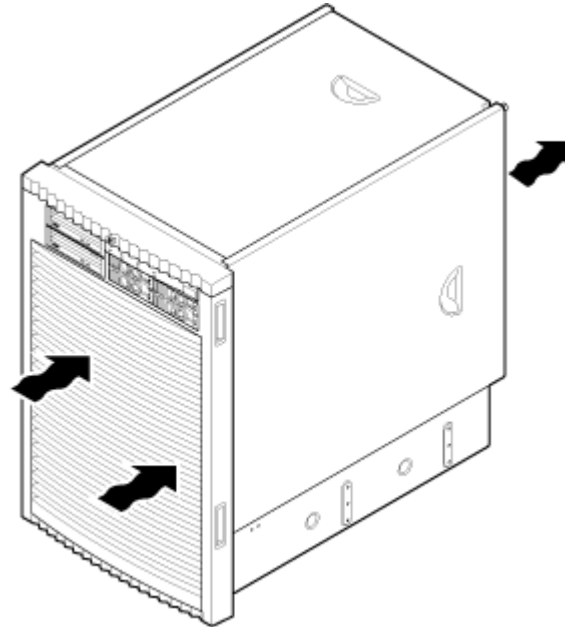

3 Installing the System

Inspect shipping containers when the equipment arrives at the site. Check equipment after the packing has been removed. This chapter discusses how to receive, inspect and install the server.

Receiving and Inspecting the Server Cabinet

This section contains information about receiving, unpacking and inspecting the server cabinet.

-
- NOTE** The server will ship in one of three different configurations. The configurations are:
- On a pallet installed in a server cabinet
 - On a pallet for rack mount into an existing cabinet on the customer site
 - On a pallet with a wheel kit for installation as a standalone server
-

HP shipping containers are designed to protect their contents under normal shipping conditions. A tilt indicator is installed on each carton shipped. The tilt indicator has two windows, and each window under normal conditions will show four beads present. If a carton has been mishandled, accidentally dropped, or knocked against something, the tilt indicator will indicate missing beads. If the container has been tilted to an angle that could cause equipment damage, the beads in the indicator will roll to the upper position.

After the equipment arrives at the customer site, carefully inspect each carton for signs of shipping damage. If the container is damaged, document the damage with photographs and contact the transport carrier immediately.

-
- NOTE** The factory provides an installation warranty that is effective from the time the customer receives the shipment until Field Services turns the system over to the customer.
- Upon inspection of a received system and during installation of the system, if any parts or accessories are missing or defective, they will be replaced directly from the factory by a priority process. To request replacement parts, the HP Installation Specialist must contact the local Order Fulfillment group which will coordinate the replacement with the factory.
-

Unpacking the Server Cabinet

This section contains information about unpacking the server cabinet.

-
- WARNING** **Wear protective glasses while cutting the plastic bands around the shipping container. These bands are under tension. When cut, they can spring back and cause serious eye injury.**
-

-
- CAUTION** Observe all ESD safety precautions before attempting these procedures. Failure to follow ESD safety precautions could result in damage to the server.
-

-
- NOTE** Position the pallet to allow enough space to roll the cabinet off the pallet before starting.
-

Remove the server cabinet using the following steps:

- Step 1.** Cut the polystrap bands around the shipping container.

Step 2. Lift the cardboard top cap from the shipping box. Refer to Figure 3-1,

Figure 3-1 Removing the Polystraps and Cardboard

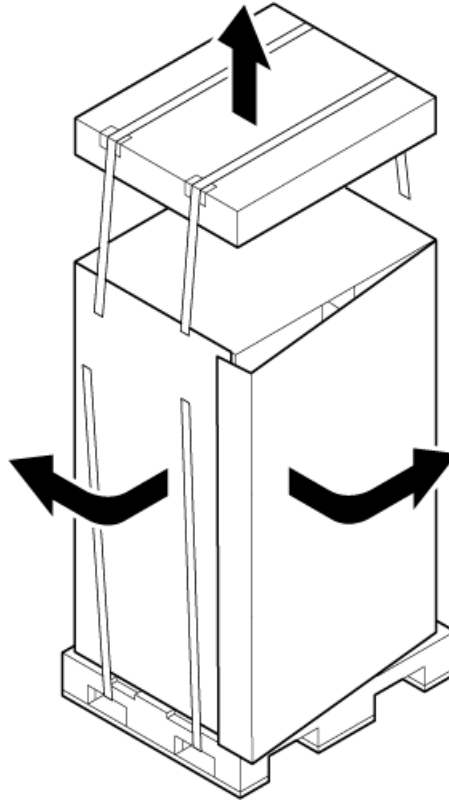

Step 3. Remove the corrugated wrap from the pallet.

Step 4. Remove the packing materials.

CAUTION Cut the plastic wrapping material off rather than pull it off. Pulling the plastic covering off represents an electrostatic discharge (ESD) hazard to the hardware.

Step 5. Remove the four bolts holding down the ramps, and remove the ramps.

NOTE Figure 3-2 shows one ramp attached to the pallet on either side of the cabinet with each ramp secured to the pallet using two bolts. In an alternate configuration, the ramps are secured together on one side of the cabinet with one bolt.

Figure 3-2 Removing the Shipping Bolts and Plastic Cover

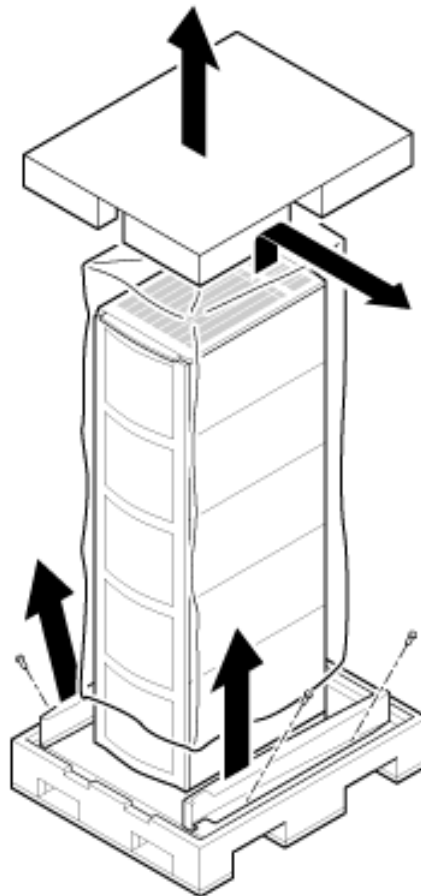

Step 6. Remove the six bolts from the base that attaches the rack to the pallet.

Figure 3-3 Preparing to Roll Off the Pallet

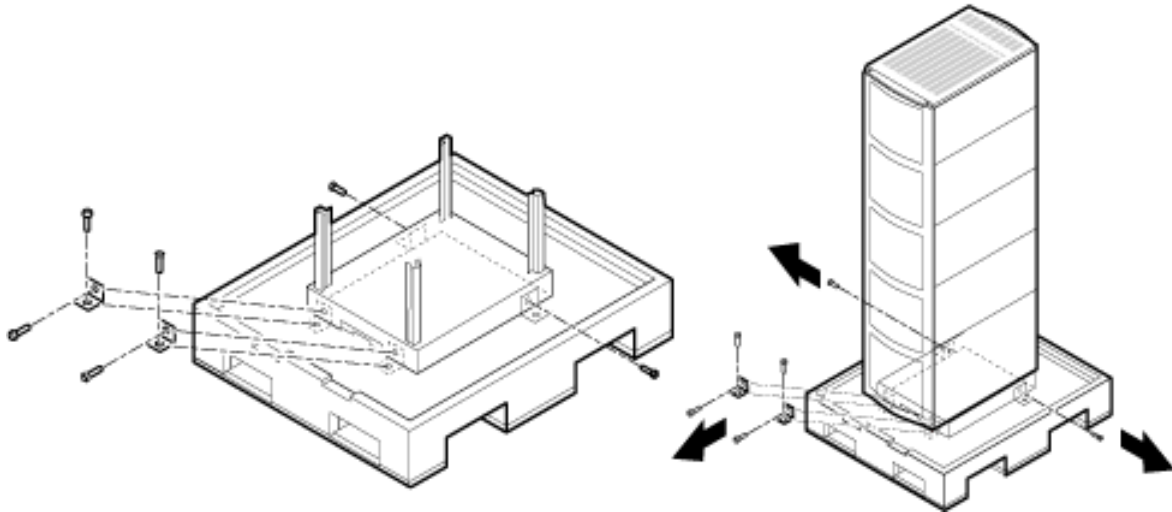

WARNING Be sure that the leveling feet on the rack are raised before you roll the rack down the ramp, and any time you roll the rack on the casters. Use caution when rolling the cabinet off the ramp. A single server in the cabinet weighs approximately 508 lb. It is strongly recommended that two people roll the cabinet off the pallet.

After unpacking the cabinet, examine it for damage that might have been obscured by the shipping container. If you discover damage, document the damage with photographs and contact the transport carrier immediately.

If the equipment has any damage, the customer must obtain a damage claim form from the shipping representative. The customer must complete the form and return it to the shipping representative.

Securing the Cabinet

When in position, secure and stabilize the cabinet using the leveling feet at the corners of the base (Figure 3-4). Install the anti-tip mechanisms on the bottom front and rear of the rack.

Figure 3-4 **Securing the Cabinet**

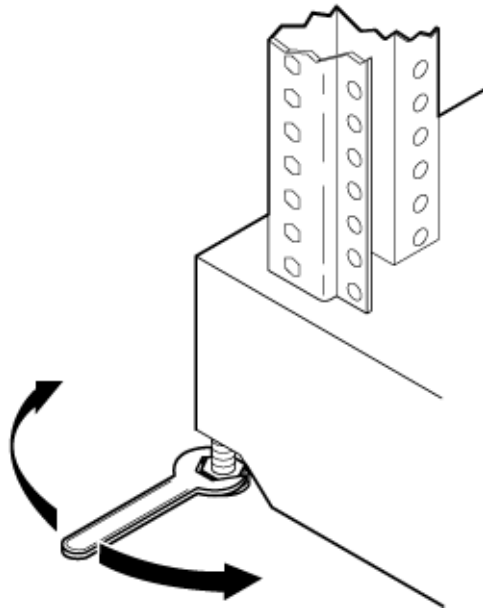

Standalone and To-Be-Racked Systems

Servers shipped in a stand-alone or to-be-racked configuration must have the core I/O handles and the PCI towel bars attached at system installation. Obtain and install the core I/O handles and PCI towel bars from the accessory kit A6093-04046. The towel bars and handles are the same part. Refer to service note A6093A-11. This is the same accessory kit used for the HP 9000 rp8400 server.

Rack-Mount System Installation

Information is available to help with rack-mounting the server. This list is intended to guide the HP Installation Specialist to the documentation that has been written by the Rack and Power team.

The external Web site is: <http://www.hp.com/racksolutions>

The internal Web site is:

<http://h18004.www1.hp.com/products/servers/proliantstorage/bcs-rackandpower/index.html>

The web site is organized into the following topics:

Racks & Accessories

- Rack System/E
- Rack accessories
- Universal mounting kits

Power Management

- PDUs
- Cordsets
- Rackmounted UPS

System Management

- Console switches
- Flat panel/keyboards

Data cables

- CAT 5 cables
- Fibre optic cables
- SCSI cables
- SCSI terminators

Lifting the Server Cabinet Manually

Use this procedure only if no HP approved lift is available.

CAUTION This procedure must only be performed by four qualified HP Service Personnel utilizing proper lifting techniques and procedures.

- Step 1.** Follow the instructions on the outside of the service packaging to remove the banding and cardboard top from the server pallet.
- Step 2.** Reduce the weight by removing all bulk power supplies and cell boards. Place each on an ESD approved surface.

CAUTION System damage can occur through improper removal and reinstallation of bulk power supplies and cell boards. Refer to Chapter 6, “Removal and Replacement” for the correct procedures to remove and reinstall these components.

- Step 3.** Locate the four positioning handles on the sides of the system. They are colored blue and located close to each base corner of the unit.
- Step 4.** Ensure that the vertical support brackets are in the position so that they rest on the slides when the server is lowered to the rack slides. There are two brackets on each side of the server chassis.
- Step 5.** Unfold the handles so that they are extended out from the unit. The server is now ready for manual lifting by the four qualified HP Service Personnel.
- Step 6.** Lift the server into place and secure as required.
- Step 7.** After the server is secured, reinstall the previously removed cell boards and bulk power supplies.

Using the RonI Model 17000 SP 400 Lifting Device

Use the lifter designed by the RonI company to rack-mount the server. The lifter can raise 400 lb/182 kg to a height of 5 feet. The lifter can be broken down into several components. When completely broken down, no single component weighs more than 25 lb/12 kg. The ability to break the lifter down makes it easy to transport from the office to the car and then to the customer site.

Documentation for the RonI lifter has been written by RonI and is available on the HP Cybrary: <http://cybrary.inet.cpqcorp.net/ARCHIVE/PUBS/USERS/LIFTOFLEX-17000.pdf>. Complete details on how to assemble the lifter, troubleshoot the lifter, and maintain the lifter are provided by RonI.

Use the following procedure to unload the server from the pallet after the lifter is assembled.

WARNING Use caution when using the lifter. To avoid injury, because of the weight of the server, center the server on the lifter forks before raising it off the pallet.

Always rack the server in the bottom of a cabinet for safety reasons. Never extend more than one server from the same cabinet while installing or servicing another server product. Failure to follow these instructions could result in the cabinet tipping over.

Step 1. Obtain the *HP J1528B Rack Integration Kit Installation Guide* before proceeding with the rack-mount procedure. This guide covers these important steps:

- Installing the anti-tip stabilizer kit (A5540A)
- Installing the ballast kit (J1479A)
- Installing the barrel nuts on the front and rear columns
- Installing the slides

Step 2. Follow the instructions on the outside of the server packaging to remove the banding and carton top from the server pallet.

Step 3. Insert the lifter forks between the cushions (Figure 3-5).

Figure 3-5 Positioning the Lifter to the Pallet

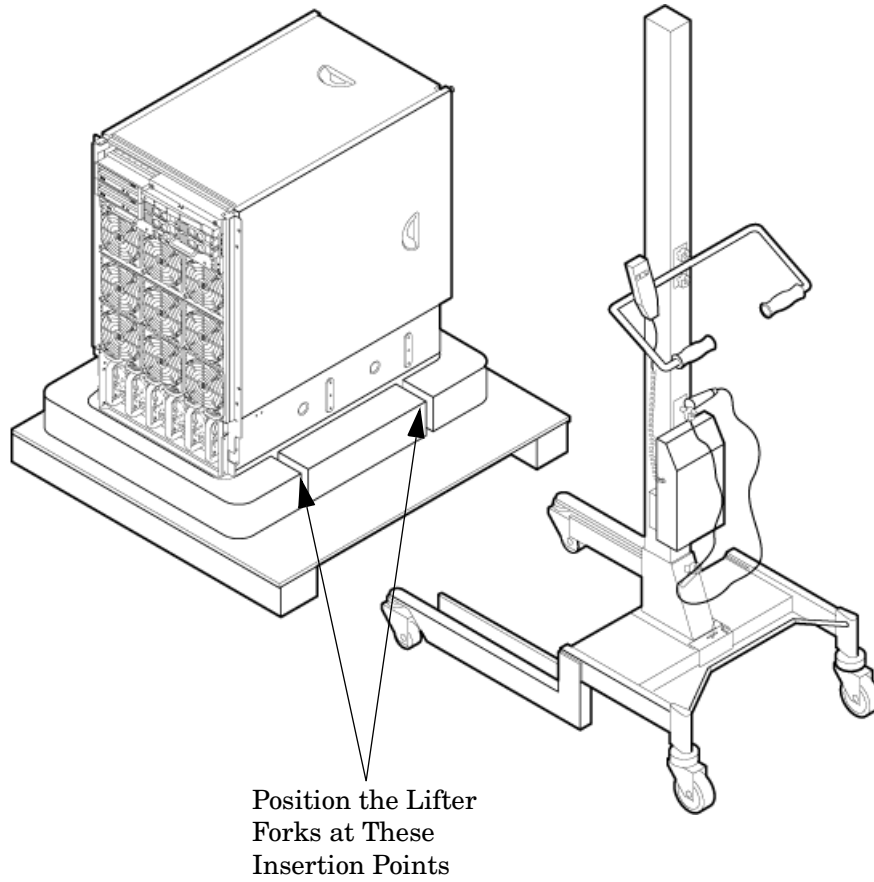

Step 4. Carefully roll the lift forward until it is fully positioned against the side of the server.

Step 5. Slowly raise the server off the pallet until it clears the pallet cushions (Figure 3-6).

Figure 3-6 Raising the Server Off the Pallet Cushions

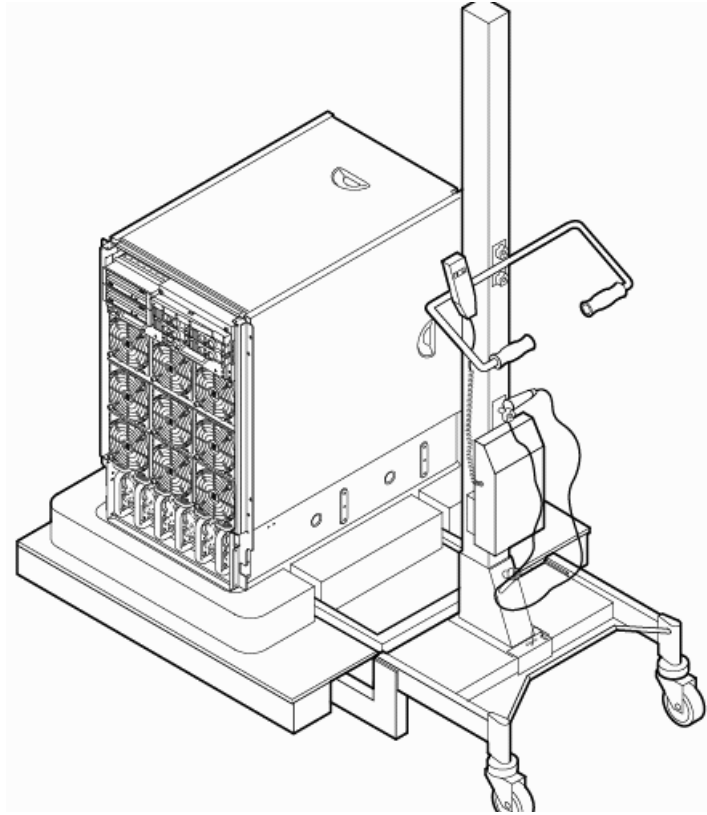

Step 6. Carefully roll the lifter and server away from the pallet. Do not raise the server any higher than necessary when moving it over to the rack.

Step 7. Follow the *HP J1528B Rack Integration Kit Installation Guide* to complete these steps:

- Mounting the server to the slides
- Installing the cable management arm (CMA)
- Installing the interlock device assembly (if two servers are in the same cabinet)

Installing the Wheel Kit

Compare the packing list (Table 3-1) with the contents of the wheel kit before beginning the installation. For a more updated list of part numbers, go to the HP Part Surfer web site at: <http://www.partsurfer.hp.com>.

Table 3-1 Wheel Kit Packing List

Part Number	Description	Quantity
A9904-04002	Caster cover	2
A9904-04007	Right side cover	1
A9904-04008	Left side cover	1
A9904-04009	Top cover	1
A6093-04082	Right front caster assembly	1
A6093-04083	Right rear caster assembly	1
A6093-04084	Left front caster assembly	1
A6093-04085	Left rear caster assembly	1
0515-2478	M4 x 0.7 8mm T15 steel zinc machine screw (used to attach each caster to the chassis)	8
A6093-44013	Plywood unloading ramp	1
Not Applicable	Phillips head wood screw (used to attach the ramp to the pallet)	2

Tools Required for Installation

Use the following tools to perform the wheel kit installation:

- Diagonal side cutters
- Safety glasses
- Torx screwdriver with T-15 bit
- Phillips head screwdriver

WARNING **Wear protective glasses while cutting the plastic bands around the shipping container. These bands are under tension. When cut, they can spring back and cause serious eye injury.**

Use the following procedure to install the wheel kit.

- Step 1.** Cut and remove the polystrap bands securing the server to the pallet.
- Step 2.** Lift the carton top from the cardboard tray resting on the pallet.
- Step 3.** Remove the bezel kit carton and top cushions (Figure 3-7) from the pallet.

Figure 3-7 Server on Shipping Pallet

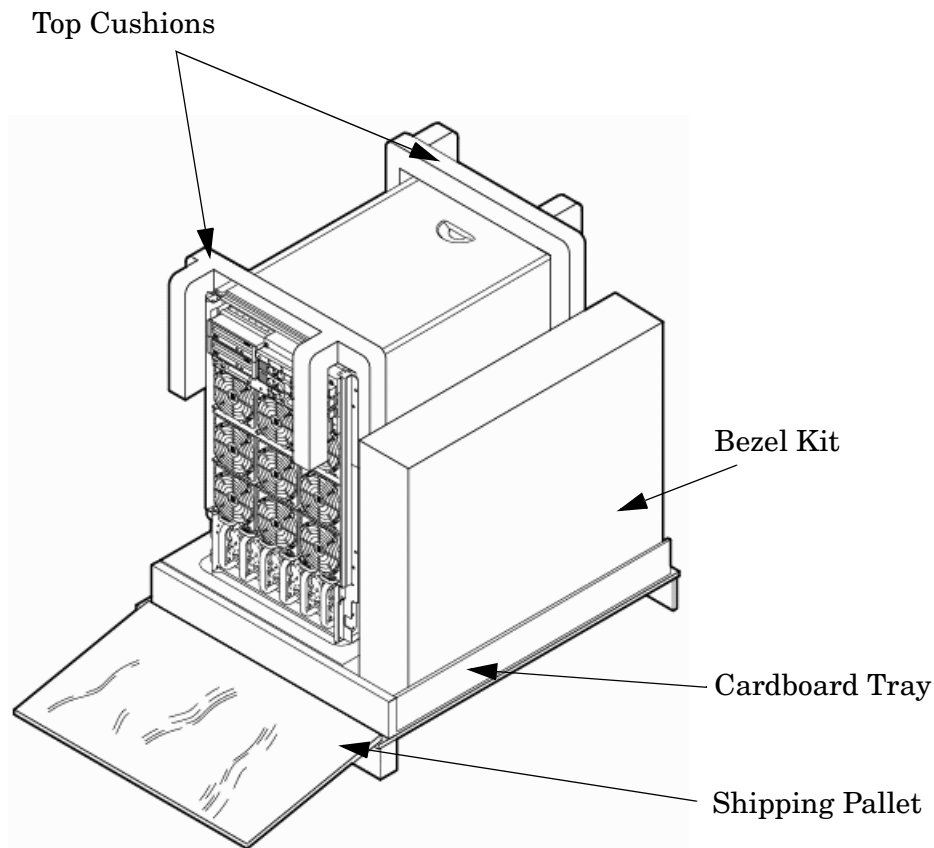

- Step 4.** Unfold bottom cardboard tray.

Step 5. Remove the front cushion only (Figure 3-8). Do not remove any other cushions until further instructed.

Figure 3-8 Removing Cushion from Front Edge of Server

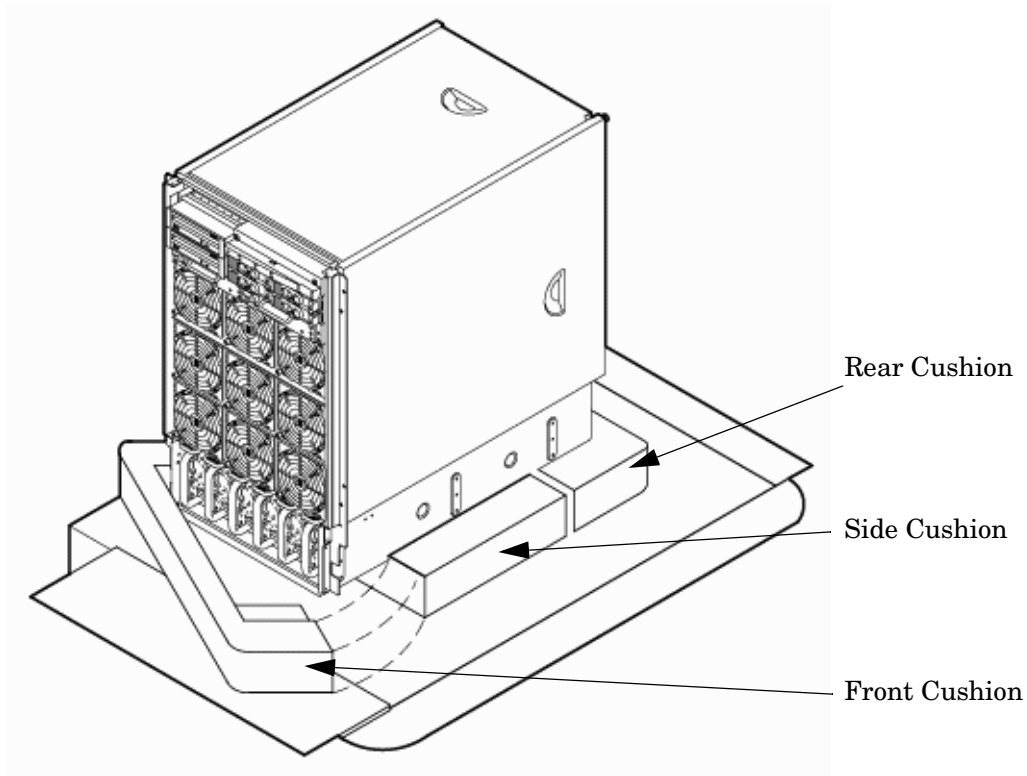

Step 6. Open the wheel kit box and locate the two front casters. The front casters are shorter in length than the two rear casters. Each front caster is designed to fit only on one corner of the server (right front caster and left front caster).

- Step 7.** Remove two of the eight screws from the plastic pouch. Attach one wheel caster to the front of the server (Figure 3-9).

Figure 3-9 Attaching a Caster Wheel to the Server

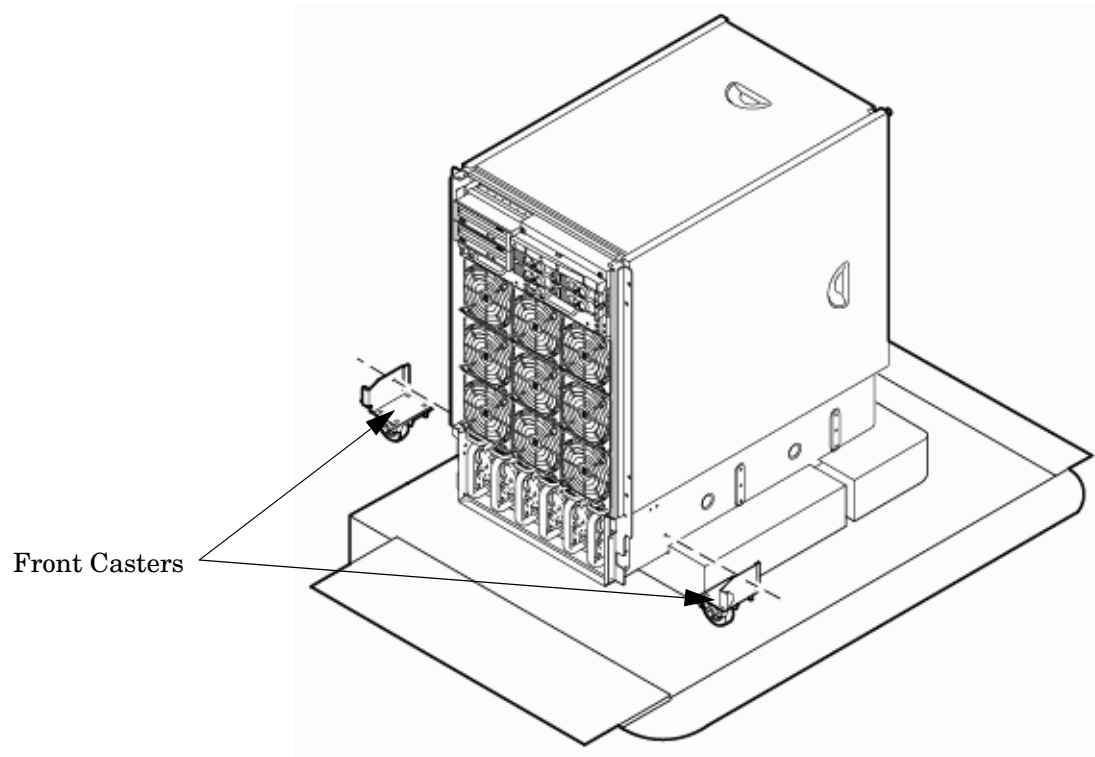

- Step 8.** Attach the remaining front caster to the server using two more screws supplied in the plastic pouch.
- Step 9.** Remove the rear cushion at the rear of the server. Do not remove the remaining cushions.
- Step 10.** Mount the two rear casters to the server using the remaining four screws.
- Step 11.** Obtain the plywood ramp from the wheel kit.

Step 12. The ramp has two ppredrilled holes (Figure 3-10). Attach the ramp to the edge of the pallet using the two screws taped to the ramp.

Figure 3-10Attaching the Ramp to the Pallet

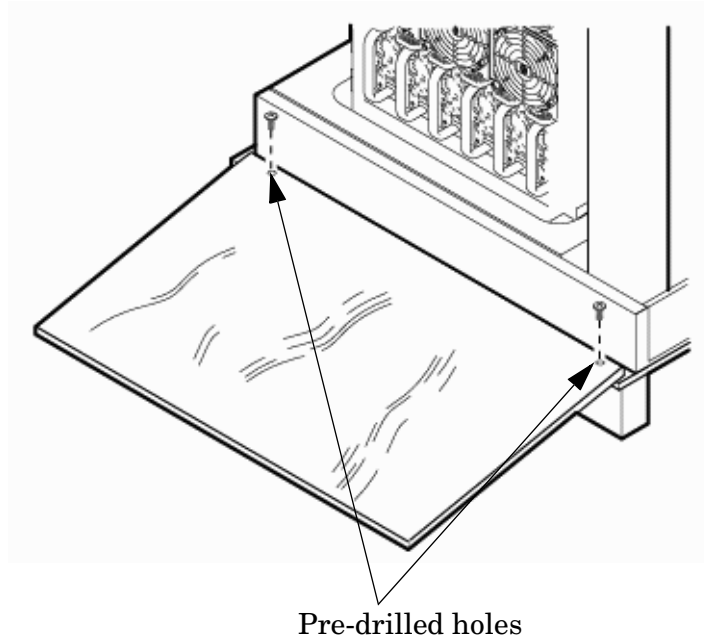

Step 13. Remove the two side cushions from the server, (Figure 3-11) and unfold the cardboard tray so that it lays flat on the pallet.

Figure 3-11 Removing Side Cushion from Server

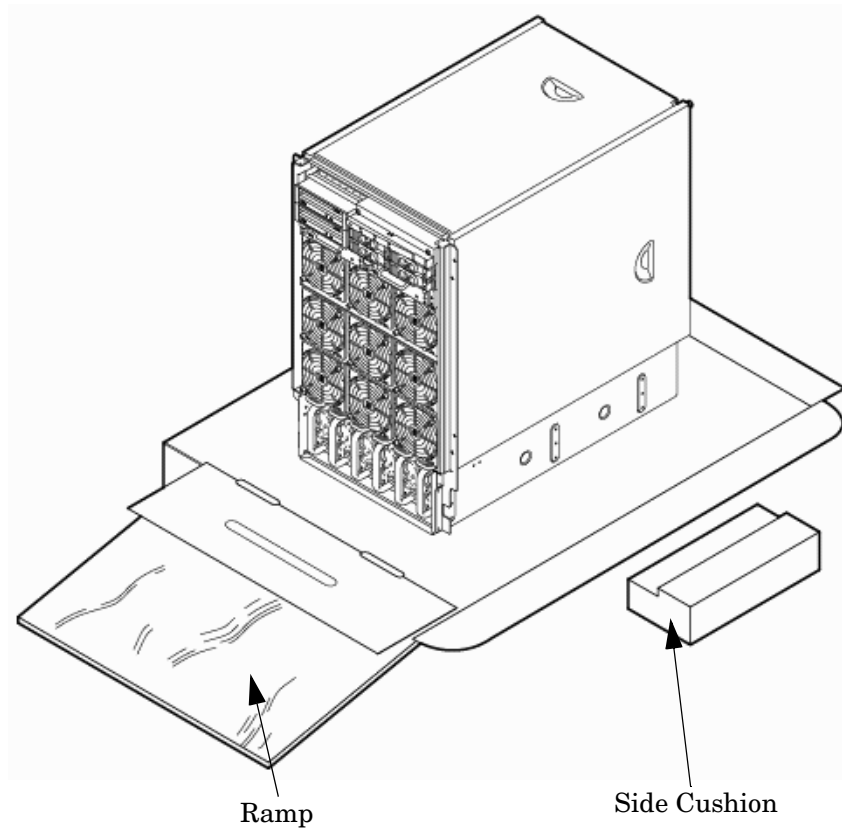

Step 14. Carefully roll the server off the pallet and down the ramp.

Step 15. Obtain the caster covers from the wheel kit. Note that the caster covers are designed to fit on either side of the server.

Step 16. Insert the slot on the caster cover into the front caster (Figure 3-12). Secure the caster cover to the server by tightening the captive screw on the cover at the rear of the server. Repeat for the second caster cover.

Figure 3-12 Securing Each Caster Cover to the Server

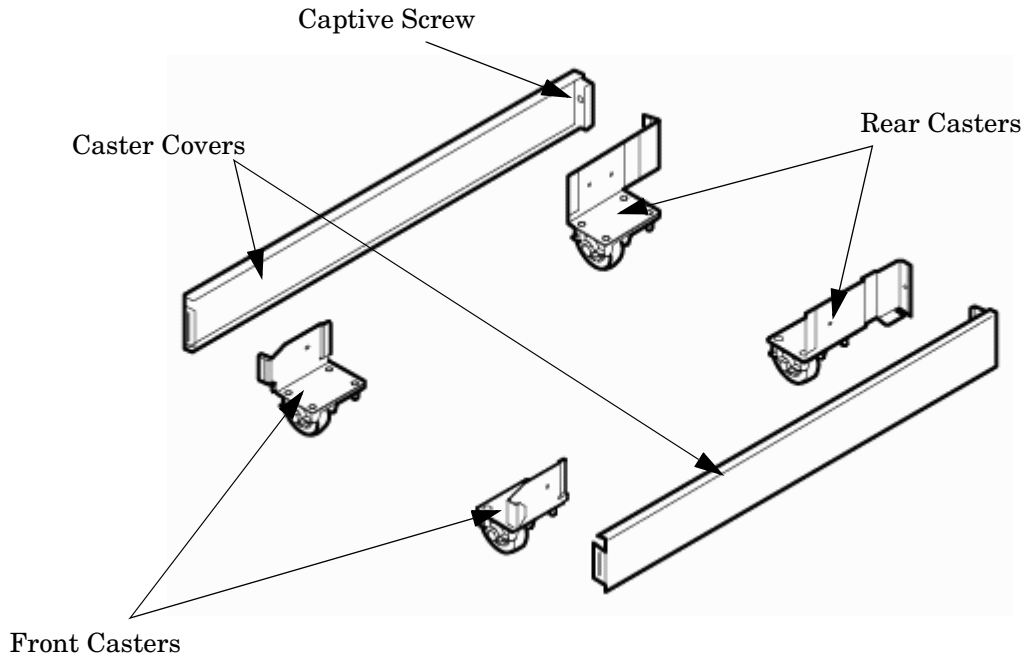

Step 17. Snap the bezel cover into place on the front of the server. Figure 3-13 shows the server cabinet with the wheel kit installed.

Figure 3-13 Completed Wheel Kit Installation

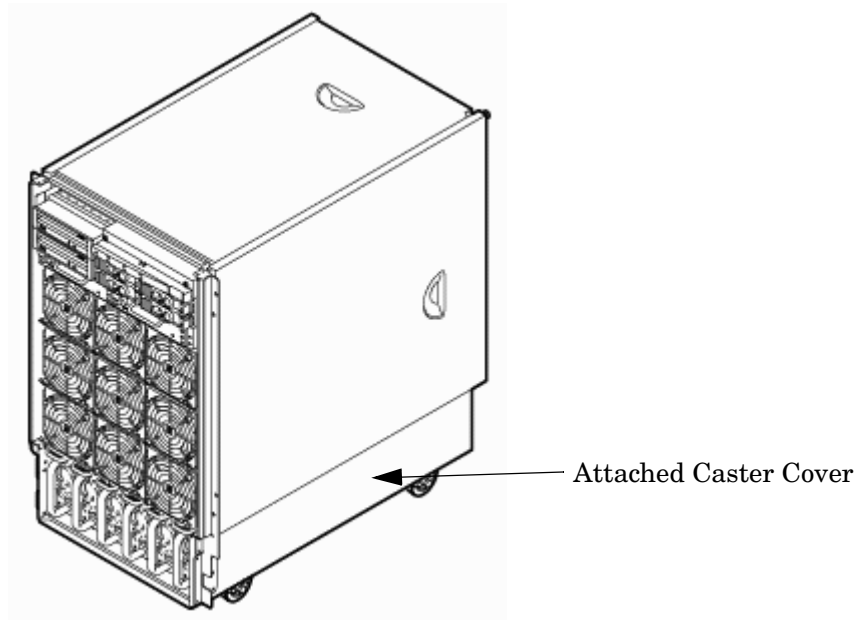

Installing the Top and Side Covers

This section describes the procedures for installing the top and side server covers.

NOTE You may need to remove existing top and side covers installed on the server before installing the covers shipped with the wheel kit. If cover removal is not needed, go directly to the sections for installing the top and side cover.

Figure 3-14 Cover Locations

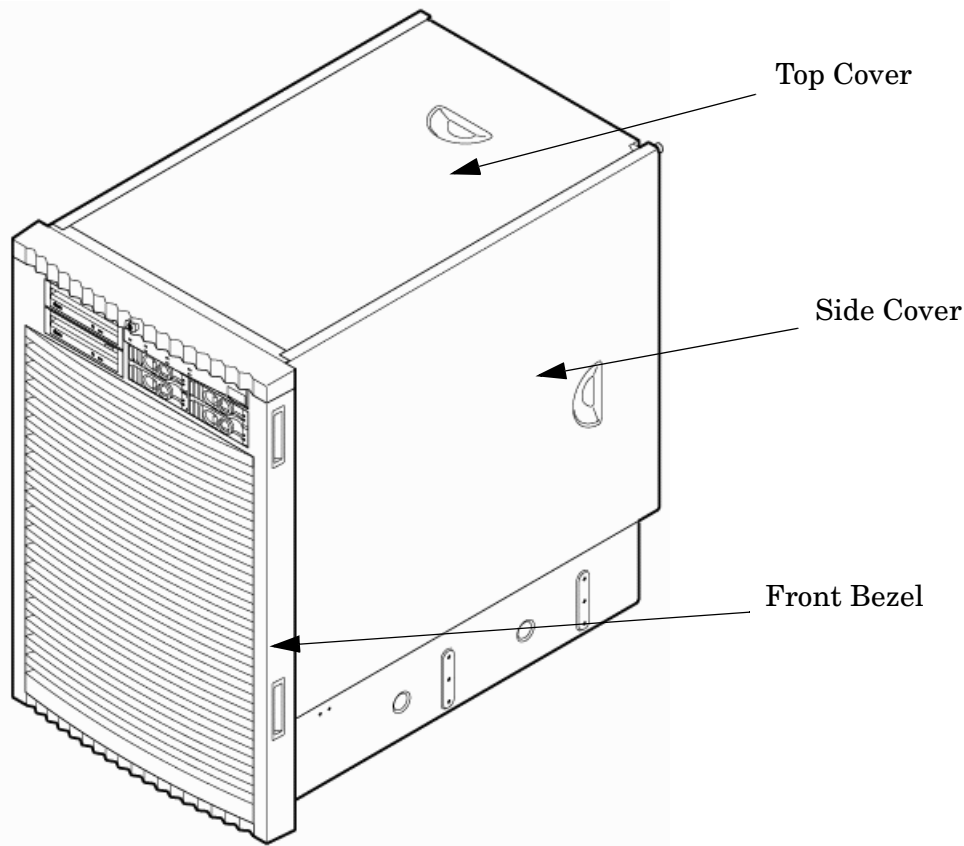

Removing the Top Cover

The following section describes the procedure for removing the top cover.

- Step 1.** Connect to ground with a wrist strap.
- Step 2.** Loosen the blue retaining screws securing the cover to the chassis (Figure 3-15 on page 76).
- Step 3.** Slide the cover toward the rear of the chassis.
- Step 4.** Lift the cover up and away from the chassis.

Step 5. Place the cover in a safe location.

Figure 3-15 **Top Cover Detail**

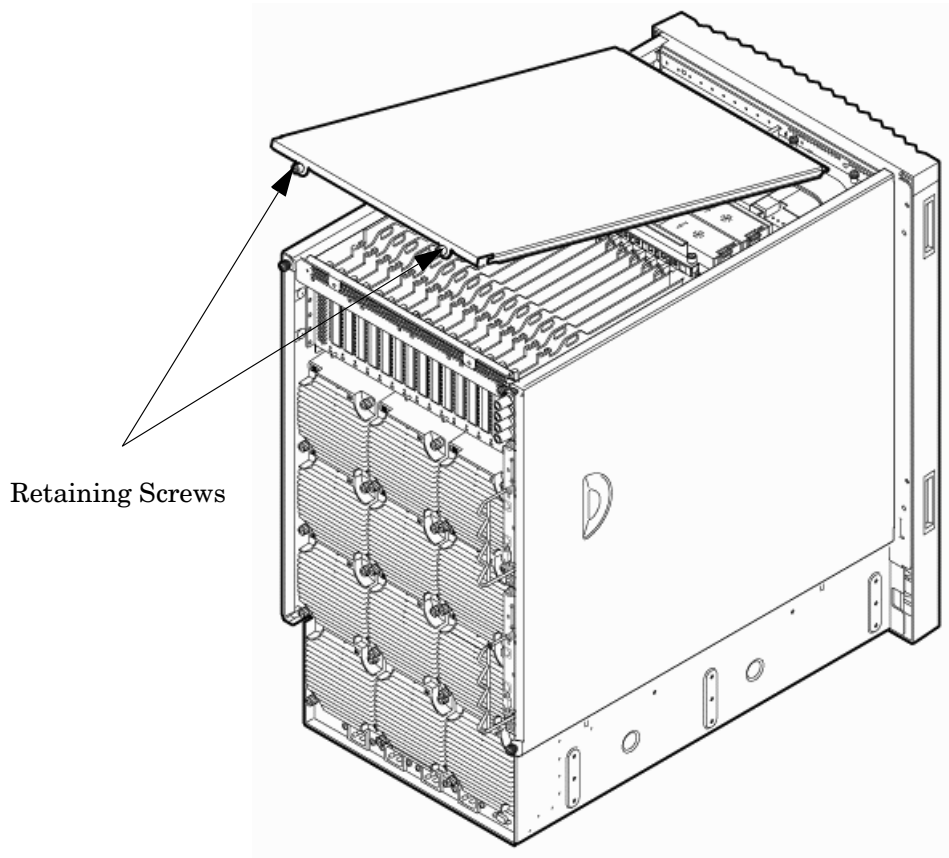

Installing the Top Cover

The following section describes the procedure for installing the top cover.

- Step 1.** Orient the cover according to its position on the chassis.
- Step 2.** Slide the cover into position using a slow, firm pressure to properly seat the cover.
- Step 3.** Tighten the blue retaining screws securing the cover to the chassis.

Removing the Side Cover

The following section describes the procedure for removing the side cover.

- Step 1.** Connect to ground with a wrist strap.

Step 2. Loosen the blue retaining screw securing the cover to the chassis (Figure 3-16).

Figure 3-16 **Side Cover Detail**

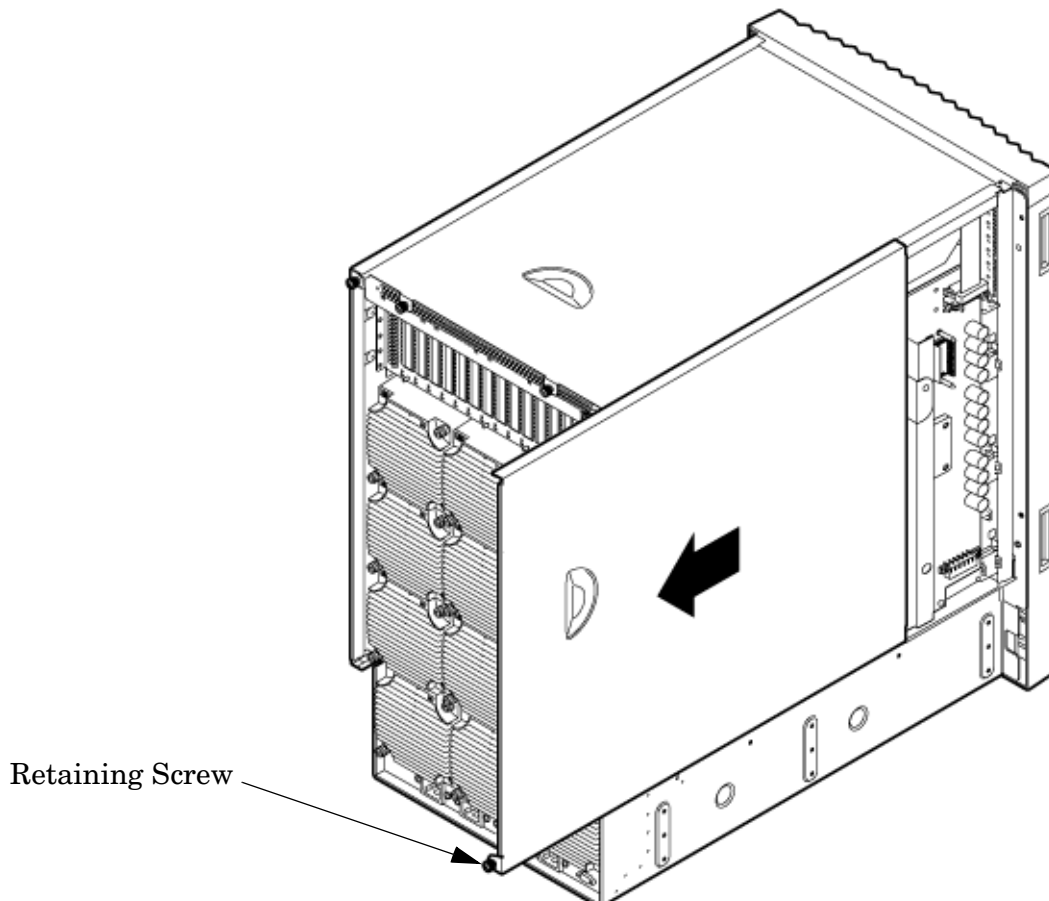

Step 3. Slide the cover from the chassis toward the rear of the system.

Step 4. Place the cover in a safe location.

Installing the Side Cover

The following section describes the procedure for installing the side cover.

Step 1. Orient the cover according to its position on the chassis.

Step 2. Slide the cover into position using a slow, firm pressure to properly seat the cover.

Step 3. Tighten the blue retaining screw securing the cover to the chassis.

Installing the Power Distribution Unit

The server may ship with a power distribution unit (PDU). Two 60 A PDUs available for the server. Each PDU 3 U high and is mounted horizontally between the rear columns of the server cabinet. The 60 A PDUs are delivered with an IEC-309 60 A plug.

The 60 A NEMA¹ PDU has four 20 A circuit breakers and is constructed for North American use. Each of the four circuit breakers has two IEC²-320 C19 outlets providing a total of eight IEC-320 C19 outlets.

The 60A IEC PDU has four 16A circuit breakers and is constructed for International use. Each of the four circuit breakers has two IEC-320 C19 outlets providing a total of eight IEC-320 C19 outlets.

Each PDU is 3U high and is rack-mounted in the server cabinet.

Documentation for installation will accompany the PDU. The documentation can also be found at the external Rack Solutions Web site at:

<http://www.hp.com/racksolutions>

This PDU might be referred to as a Relocatable Power Tap outside HP.

The PDU installation kit contains the following:

- PDU with cord and plug
- Mounting hardware
- Installation instructions

1. NEMA: National Electrical Manufacturers Association

2. IEC: International Electrotechnical Commission

Installing Additional Cards and Storage

This section provides information on additional products ordered after installation and any dependencies for these add-on products.

The following options can be installed in the server:

- Hard disk drive storage
- Removable media device storage
- PCI/PCI-X I/O cards

Installing an Additional Hard Disk Drive

The disk drives are located in the front of the chassis (Figure 3-17). The hard disk drives are hot-plug drives. A list of replacement disk drives for the server is in Appendix A of the HP Service Guide. The list contains both removable media disk drives and hard disk drives.

Figure 3-17 Disk Drive Location

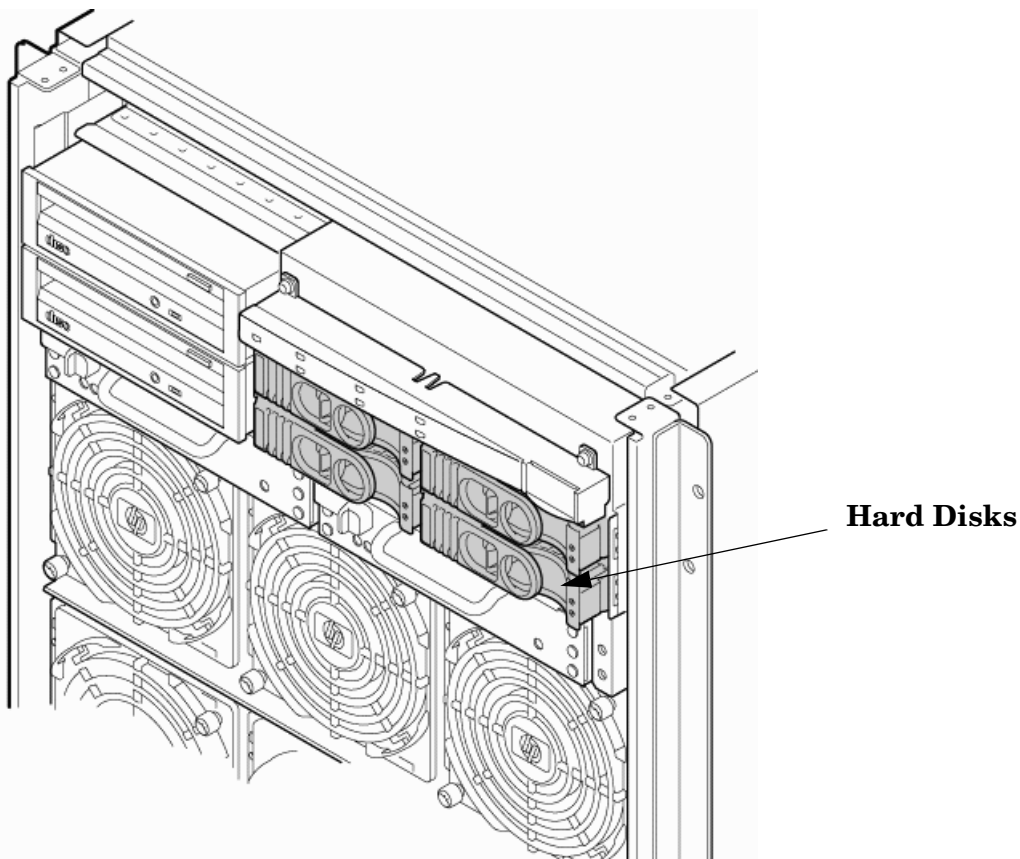

Use the following procedure to install the disk drives:

- Step 1.** Be sure the front locking latch is open, then position the disk drive in the chassis.
- Step 2.** Slide the disk drive into the chassis; apply a slow, firm pressure to properly seat the connector.

Step 3. Press the front locking latch to secure the disk drive in the chassis.

Step 4. If the server OS is running, spin up the disk by entering one of the following commands:

```
#diskinfo -v /dev/rdisk/cxtxdx  
  
#ioscan -f
```

Removable Media Drive Installation

The DVD drive or DDS-4 tape drives are located in the front of the chassis.

Figure 3-18 Removable Media Drive Location

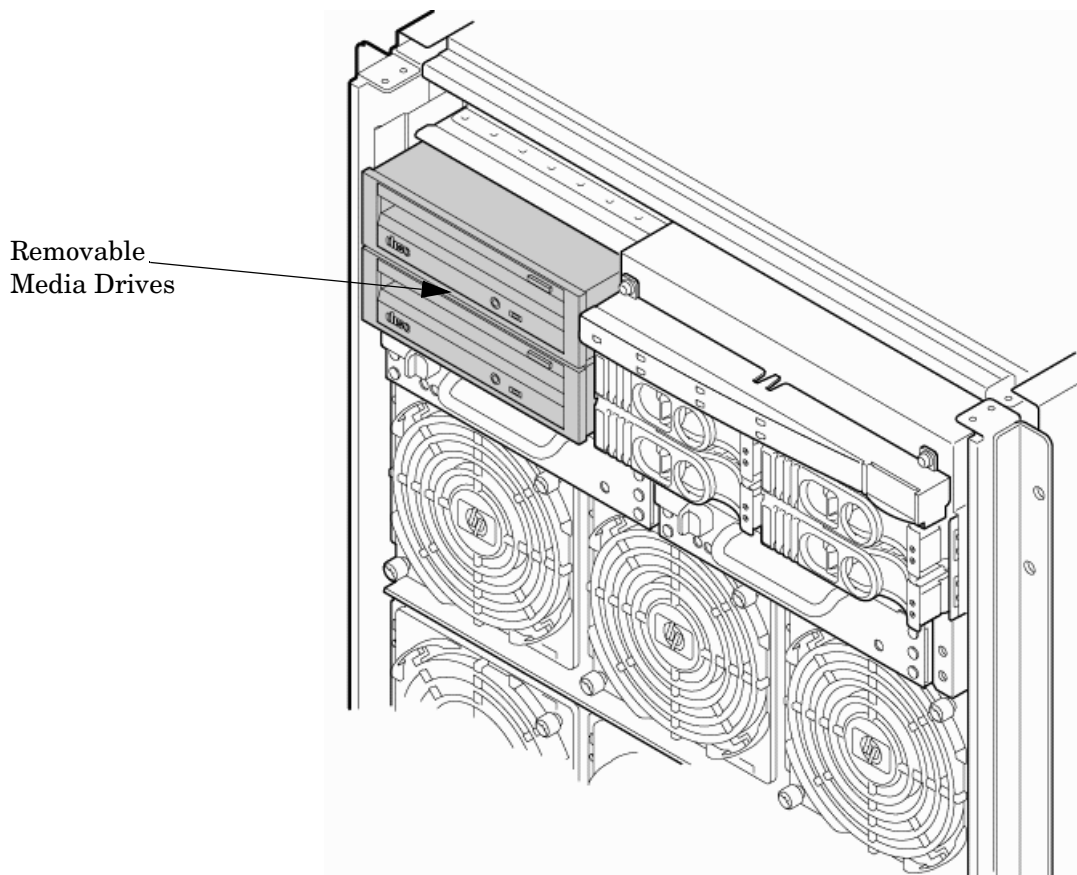

If an upper drive is installed, remove it before installing a lower drive.

Step 1. Remove the filler panel.

Step 2. Connect the cables to the rear of the drive.

Step 3. Install left and right media rails and clips.

Step 4. Slide the drive in the chassis. Fold the cables out of the way.

Step 5. Apply a slow, firm pressure to properly seat the drive in the chassis.

Step 6. Latch the front locking tab to secure the drive in the chassis.

HP Integrity rx8640 Supported PCI/PCI-X I/O Cards

The rx8640 server supports a number of PCI and PCI-X I/O cards. Table 3-2 lists the cards currently supported on the server. For a more updated list of part numbers, go to the HP Part Surfer web site at: <http://www.partsurfer.hp.com>.

Table 3-2 HP Integrity rx8640 Server PCI-X I/O Cards

Part Number	Card Description	HP-UX 11i V2	Windows®	Linux®	VMS
A4926A	Gigabit Ethernet (1000b-SX)				
A4929A	Gigabit Ethernet (1000b-T)				
A5158A	FCMS - Tachlite				
A5230A	10/100b-TX (RJ45)				
A5506B	4-port 10/100b-TX				
A5838A	2-port Ultra2 SCSI/2-Port 100b-T Combo				
A6386A	Hyperfabric II				
A6749A	64-port Terminal MUX				
A6795A	2G FC Tachlite	B			
A6825A	Next Gen 1000b-T	b	b		
A6826A ¹	2-port 2Gb FC	B			B
A6828A	1-port U160 SCSI	B	B		
A6829A	2-port U160 SCSI	B	B		
A6847A	Next Gen 1000b-SX	b	b		
A6869B ²	Obsidian 2 VGA/USB	B			B
A7011A	1000b-SX Dual Port	b	b	b	
A7012A	1000b-T Dual Port	b	b	b	
A7173A	2-port U320 SCSI	B	B	B	B
A9782A ¹	1000b-T GigE/2G FC Combo	Bb			B
A9784A ¹	PCI-X 1000b-T GigE/2G FC Combo	Bb			B
A9890A	2-port Smart Array 6402 (U320)	B	B	B	B
A9891A	4-port Smart Array 6402 (U320)	B	B		B
AB232A ¹	Emulex 9802 Fibre Channel		B		
AB286A	PCI-X 2-port 4X InfiniBand HCA (HPC)				

Table 3-2 HP Integrity rx8640 Server PCI-X I/O Cards (Continued)

Part Number	Card Description	HP-UX 11i V2	Windows®	Linux®	VMS
AB286C	PCI-X 2-Port 4X InfiniBand HCA (HPC)-RoHS				
AB287A	10 GbE - Fiber (PCI-X 133)	b	b	b	
AB290A	U320 SCSI/GigE Combo Card	Bb	Bb	Bb	B
AB345A	PCI-X 2-port 4X InfiniBand HCA				
AB345C	PCI-X 2-port 4X InfiniBand HCA-RoHS				
AB378A ¹	QLogic 1-port 4Gb FC card (PCI-X 266)	B			B
AB379A ¹	QLogic 2-port 4Gb FC card (PCI-X 266)	B	B	B	B
AB429A ¹	1-Port 4Gb FC QLogic – AB378A equivalent		B	B	
AB465A ¹	2-port 1000b-T 2Gb FC Combo	Bb			B
AB466A ¹	Emulex 1050DC Fibre Channel		B		
AB467A ¹	Emulex 1050D Fibre Channel		B		
AB545A	4-Port 1000b-T Ethernet	b			
AD167A ¹	Emulex 4Gb/s		B	B	
AD168A ¹	Emulex 4Gb/s DC		B	B	
AD278A	8-Port Terminal MUX				
AD279A	64-Port Terminal MUX				
J3525A	2-port Serial				
337972-B21	SA P600 (Redstone)		B	B	

B- Supports Mass Storage Boot

b- Supports LAN Boot

Bb- Support Mass Storage and LAN Boot

1. Factory integration (software load) of the OpenVMS, Windows, and Linux operating systems via Fibre Channel is NOT supported.
2. Boot support is limited to OS installation, updating, and repairing media.

HP 9000 rp8440 Supported PCI/PCI-X I/O cards

Table 3-3 lists the PCI/PCI-X cards supported in the rp8440 server.

Several cards lose boot functionality when upgrading the server. The customer must use another I/O card to retain boot functionality if the customer's card is not supported in the server.

Table 3-3 HP 9000 rp8440 Server PCI-X I/O Cards

Part Number	Card Description	HP-UX 11i V1	n/a	n/a	n/a
A4926A	Gigabit Ethernet (1000b-SX)				
A4929A	Gigabit Ethernet (1000b-T)				
A5158A	FCMS - Tachlite				
A5159B	2-port FWD SCSI	B			
A5230A	10/100b-TX (RJ45)				
A5506B	4-port 10/100b-TX				
A5838A	2-port Ultra2 SCSI/2-Port 100b-T Combo	B			
A6386A ¹	Hyperfabric II				
A6749A	64-port Terminal MUX				
A6795A ¹	2G FC Tachlite	B			
A6825A ¹	Next Gen 1000b-T	b			
A6826A ¹	2-port 2Gb FC	B			
A6828A	1-port U160 SCSI	B			
A6829A	2-port U160 SCSI	B			
A6847A ¹	Next Gen 1000b-SX	b			
A7011A ¹	1000b-SX Dual Port	b			
A7012A ¹	1000b-T Dual Port	b			
A7143A	U160 RAID - SmartArray 5304	B			
A7173A ¹	2-port U320 SCSI	B			
A9782A ¹	1000b-T GigE/2G FC Combo	Bb			
A9784A ¹	PCI-X 1000b-T GigE/2G FC Combo	Bb			
A9890A ¹	2-port Smart Array 6402 (U320)	B			
A9891A ¹	4-port Smart Array 6402 (U320)	B			

Table 3-3 HP 9000 rp8440 Server PCI-X I/O Cards (Continued)

Part Number	Card Description	HP-UX 11i V1	n/a	n/a	n/a
AB287A ¹	10 GbE - Fiber (PCI-X 133)				
AB290A ¹	U320 SCSI/GigE Combo Card	Bb			
AB378A ¹	QLogic 1-port 4Gb FC card (PCI-X 266)	B			
AB378B ¹	QLogic 1-port 4Gb FC card (PCI-X 266)	B			
AB379A ¹	QLogic 2-port 4Gb FC card (PCI-X 266)	B			
AB379B ¹	QLogic 2-port 4Gb FC card (PCI-X 266)	B			
AB465A ¹	2-port 1000b-T 2Gb FC Combo	Bb			
AB545A ¹	4-Port 1000b-T Ethernet	b			
AD193A ¹	1-port 4Gb FC & 1-port GigE HBA PCI-X RoHS	Bb			
AD194A ¹	2-port 4Gb FC & 2-port GigE HBA PCI-X RoHS	Bb			
AD278A ¹	8-Port Terminal MUX				
AD279A ¹	64-Port Terminal MUX				
AD331A ¹	PCI/PCI-X 1-Port 1000b-T Adapter	b			
AD332A ¹	PCI/PCI-X 1-Port 1000b-SX Adapter	b			
J3525A ¹	2-port Serial (X25/FR/SDLC)				

B- Supports Mass Storage Boot

b- Supports LAN Boot

Bb- Supports Mass Storage and LAN Boot

1. Available with Factory Integration

IMPORTANT The above list of part numbers is current and correct as of December 2006. Part numbers change often. Check the following website to ensure you have the latest part numbers associated with this server:

<http://partsurfer.hp.com/cgi-bin/spi/main>

Installing an Additional PCI-X I/O Card

IMPORTANT The installation process varies depending on what method for installing the PCI card is selected. Download PCI I/O card installation procedures from the <http://docs.hp.com/> Web site. Background information and procedures for adding a new PCI I/O card using online addition are described in the *Interface Card OL* Support Guide*.

Downloading Drivers

The following website contains technical support for a wide range of HP Integrity servers, including the capture of the latest drivers required for various hardware components. Refer to this site regarding necessary drivers for supported PCI cards.

See: <http://www.hp.com/support/itaniumservers>

PCI I/O OL* Card Methods

The following are three methods for performing OL* operations on PCI I/O cards:

<code>pdweb</code>	The Peripheral Device Tool (<code>pdweb</code>) Web-based method of performing OL*.
<code>olrad</code>	The command-line method of performing OL*.
Attention button	The hardware system slot based method of performing OL*.

Adding a PCI I/O Card Using the Attention Button

The following prerequisites for this procedure:

- Drivers for the card have already been installed.
- No drivers are associated with the slot.
- The green power LED is steady **OFF**. If the empty slot is in the **ON** state, use the `olrad` command or the `pdweb` tool to power the slot **OFF**.
- The yellow attention LED is steady **OFF** or is blinking if a user has requested the slot location.
- Refer to the host bus adapter (HBA) documentation for details on card installation.
- Run the `olrad -q` command to determine the status of all the PCI I/O slots.
- Obtain a copy of the interface card guide for instructions on preparing the operating system for the online addition of the PCI I/O card before attempting to insert a PCI I/O card into the PCI-X card cage assembly backplane slot.

This procedure describes how to perform an online addition of a PCI card using the attention button for cards whose drivers support online addition or replacement (OLAR). The attention button is also referred to as the doorbell.

Step 1. Remove the top cover.

Step 2. Remove the PCI bulkhead filler panel.

Step 3. Flip the PCI manual release latch (MRL) for the card slot to the open position. Refer to Figure 3-19.

Step 4. Install the new PCI card in the slot.

NOTE Apply a slow, firm pressure to properly seat the card into the backplane.

Step 5. Flip the PCI MRL for the card slot to the closed position.

CAUTION Working out of sequence or not completing the actions within each step could cause the system to crash.

Do not press the attention button until the latch is locked.

Step 6. Press the attention button.

The green power LED will start to blink.

Figure 3-19 PCI I/O Slot Details

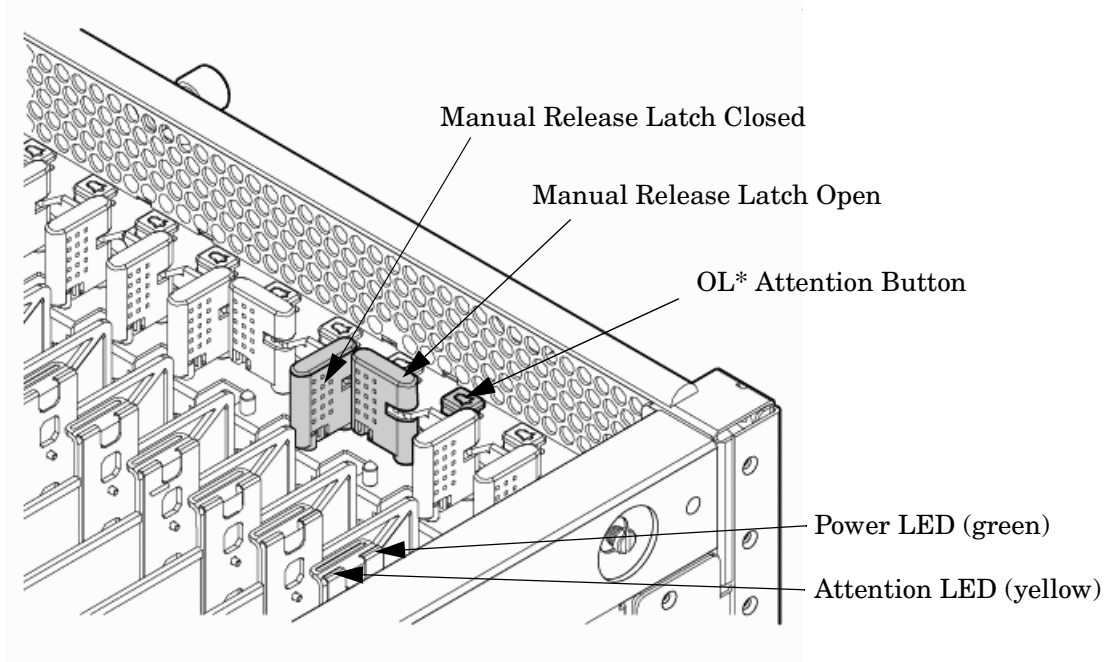

Step 7. Wait for the green power LED to stop blinking and turn on solid.

Step 8. Check for errors in the `hotplugd` daemon log file (default: `/var/adm/hotplugd.log`).

The critical resource analysis (CRA) performed while doing an attention button-initiated add action is restrictive, and the action will not complete and will fail to protect critical resources from being impacted.

For finer control over CRA actions, use the `pdweb` or the `olrad` command. Refer to the *Interface Card OL* Support Guide* located on the Web at <http://docs.hp.com>, for details.

Step 9. Replace the top cover.

Step 10. Connect all cables to the installed PCI card.

Installing an A6869B VGA/USB PCI Card in a Server

The A6869B VGA/USB PCI card is a dual function combo card, hosting VGA and universal serial bus (USB) controllers. Both of these devices sit behind a PCI-PCI bridge. The A6869B VGA/USB PCI card operates at the conventional 66MHz/64 bit PCI rate and is universally keyed. All signalling and form factors conform to the *PCI Local Bus Specification 2.3*. The VGA controller has 128Mbits of DDR-1 RAM for use as a frame buffer.

The A6869B VGA/USB PCI card can be installed into any slot in a PCI/PCI-X backplane.

IMPORTANT If you are installing the A6869B in HP servers based on the sx1000 chipset, such as HP Superdome, rx7620 or rx8620, the system firmware must be updated to a minimum revision of 3.88.

IMPORTANT Search for available PCI slots that support the conventional clock speed to conserve availability of higher speed PCI-X card slots to PCI-X cards that use the higher bandwidth. This applies to mid-range as well as high-end HP server I/O PCI-X backplanes.

Figure 3-20 PCI/PCI-X Card Location

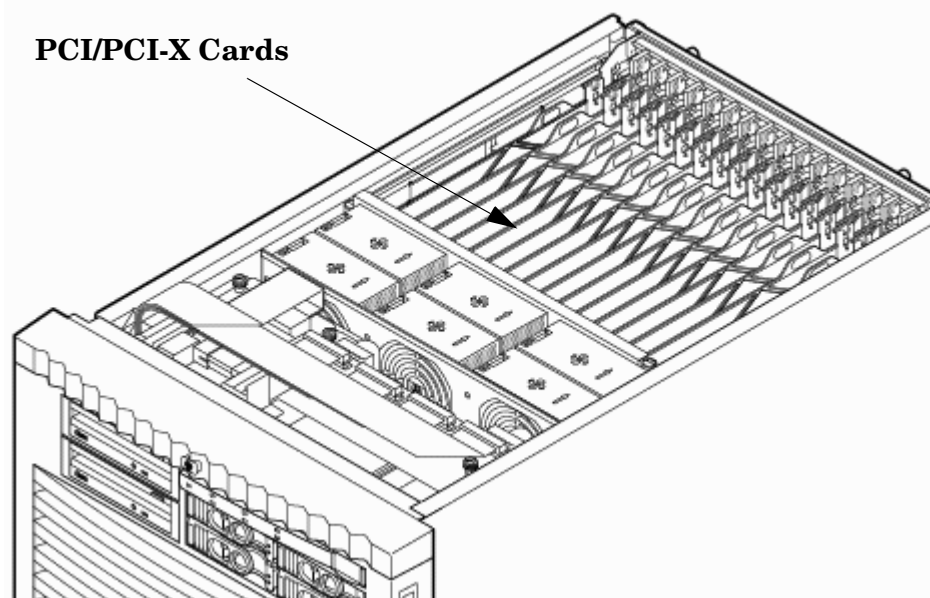

IMPORTANT Some PCI I/O cards, such as the A6869B VGA/USB PCI card, cannot be added or replaced online (while Windows remains running). For these cards, you must shut down Windows on the nPartition before performing the card replacement or addition. See the section on Shutting Down nPartitions and Powering off Hardware Components in the appropriate service guide.

1. If the A6869B VGA/USB PCI card is currently not installed, follow proper procedures to shut down the nPartition and power-off the appropriate PCI power domain.
2. Locate a vacant conventional clock speed PCI slot where the A6869B VGA/USB PCI card will reside.
3. Position the PCI card over the empty slot, observing that edge connector keyways match on the PCI backplane connector.
4. Using a slow firm pressure, seat the card down into the slot.
5. Connect the monitor, mouse, and keyboard cables to the card.
6. Connect power, and turn on the monitor.
7. Follow proper procedures to power-on the PCI power domain and boot the Windows nPartition.

Once Windows has completely booted, the video, keyboard and mouse are ready for use.

Troubleshooting the A6869B VGA/USB PCI Card

The following provides some troubleshooting solutions and a URL to a useful reference site.

No Console Display

Black Screen. No text displayed.

Hardware problem.

- * Must have supported power enabled.
- * Must have a functional VGA/USB PCI card.
- * Must have a functional PCI slot. Select another slot on same partition/backplane.
- * Must have the VGA/USB PCI card firmly seated in PCI backplane slot.
- * Must have a supported monitor.
- * Must have verified cable connections to VGA/USB PCI card.

Display unreadable.

- * Ensure system FW supports the VGA/USB PCI card.
- * Ensure graphics resolution is compatible and set correctly.

Reference URL

There are many features available for HP Servers at this website including links to download Windows Drivers.

HP Servers Technical Support

<http://www.hp.com/support/itaniumservers>

System Console Selection

Each operating system requires that the correct console type be selected from the firmware selection menu. The following section describes how to determine the correct console device.

If an operating system is being installed or the system configuration is being changed the system console setting must be checked to ensure it matches the hardware and OS. Not checking the console selection can result in the system using an unexpected device as a console, which can appear as a system hang when booting.

Step 1. Determine the console you want to use.

Depending on your operating system and your hardware you can select one of two possible devices as your system console. The possibilities are:

- Management Processor (MP) Serial Port
- VGA device

Step 2. Select the appropriate console device (deselect unused devices):

- a. Choose the “Boot option maintenance menu” choice from the main Boot Manager Menu.
- b. Select the Console Output, Input or Error devices menu item for the device type you are modifying:
 - “Select Active Console Output Devices”
 - “Select Active Console Input Devices”
 - “Select Active Console Error Devices”
- c. Available devices will be displayed for each menu selection. Figure 3-21 shows a typical output of selecting the Console Output Devices menu.

Figure 3-21 Console Output Device menu

EFI Boot Maintenance Manager ver 1.10 [14.61]

Select the Console Output Device(s)

```
Acpi(PNP0501,0)/Uart(9600 N81)/VenMsg(PcAnsi)
Acpi(PNP0501,0)/Uart(9600 N81)/VenMsg(Vt100)
Acpi(PNP0501,0)/Uart(9600 N81)/VenMsg(Vt100+)
Acpi(PNP0501,0)/Uart(9600 N81)/VenMsg(VtUtf8)
Acpi(HWP0002,700)/Pci(0|1)/Uart(9600 N81)/VenMsg(PcAnsi)
Acpi(HWP0002,700)/Pci(0|1)/Uart(9600 N81)/VenMsg(Vt100)
Acpi(HWP0002,700)/Pci(0|1)/Uart(9600 N81)/VenMsg(Vt100+)
Acpi(HWP0002,700)/Pci(0|1)/Uart(9600 N81)/VenMsg(VtUtf8)
* Acpi(HWP0003,400)/Pci(0|0)
Save Settings to NVRAM
Exit
```

- d. Choose the correct device for your system and deselect others. See “Interface Differences Between Itanium-based Systems” for details about choosing the appropriate device.
- e. Select “Save Settings to NVRAM” and then “Exit” to complete the change.
- f. A system reset is required for the changes to take effect.

VGA Consoles

Any device that has a PCI section in its path and does not have a UART section will be a VGA device. If you require a VGA console, choose the device and unmark all others. Figure 3-21 shows that a VGA device is selected as the console.

Interface Differences Between Itanium-based Systems

Each Itanium-based system has a similar interface with minor differences. Some devices may not be available on all systems depending on system design or installed options.

Other Console Types

Any device that has a Uart section but no Pci section is a system serial port. To use the system serial port (if available) as your console device, select the system serial device entry that matches your console type (PcAnsi, Vt100, Vt100+, VtUtf8) and deselect everything else.

If you choose either a system or MP serial port HP recommends that you use a vt100+ capable terminal device.

Additional Notes on Console Selection

Each Operating System makes decisions based on the EFI Boot Maintenance Manager menu’s Select Active Console selections to determine where to send its output. If incorrect console devices are chosen the OS may fail to boot or will boot with output directed to the wrong location. Therefore, any time new potential console devices are added to the system or anytime NVRAM on the system is cleared console selections should be reviewed to ensure that they are correct.

Cabling and Powering On the Server

After the system has been unpacked and moved into position, it must be connected to a source of AC power. The AC power must be checked for the proper voltage before the system is powered up. This chapter describes these activities.

Checking the Voltage

This section provides voltage check information for use on the customer site. The emphasis is on measuring the voltages at the power cord plug end specified as an IEC-320 C19 type plug. This is the end that plugs directly into the back of the server cabinet.

NOTE Perform these procedures for each power cord that will be plugged directly into the back of the server cabinet. If you do not obtain the expected results from this procedure during the voltage check, refer to the section titled “Voltage Check (Additional Procedure)” on page 97.

Verifying the Voltage Range of the Receptacle

Use this procedure to measure the voltage between L1 and L2, L1 to ground, and L2 to ground. Refer to Figure 3-22 for voltage reference points when performing the following measurements.

Figure 3-22 Voltage Reference Points for IEC-320 C19 Plug

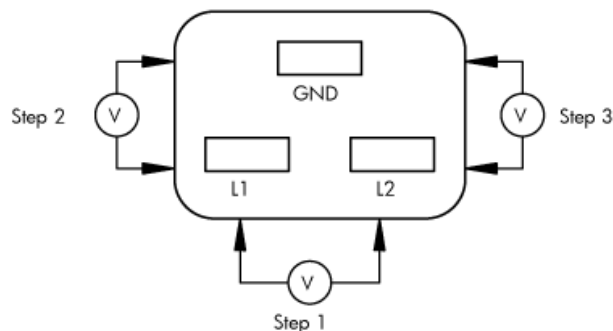

IMPORTANT Perform these measurements for every power cord that plugs into the server.

- Step 1.** Measure the voltage between L1 and L2. This is considered to be a phase-to-phase measurement in North America. In Europe and certain parts of Asia-Pacific, this measurement is referred to as a phase-to-neutral measurement. The expected voltage should be between 200–240 V AC regardless of the geographic region.
- Step 2.** Measure the voltage between L1 and ground. In North America, verify that this voltage is between 100–120 V AC. In Europe and certain parts of Asia-Pacific, verify that this voltage is between 200–240 V AC.
- Step 3.** Measure the voltage between L2 and ground. In North America, verify that this voltage is between 100–120 V AC. In Europe and certain parts of Asia-Pacific, verify that this voltage is 0 (zero) V AC.

Table 3-4 provides single phase voltage measurement examples specific to the geographic region where these measurements are taken.

Table 3-4 Single Phase Voltage Examples

	Japan	North America	Europe ^a
L1 to L2	210 V	208 V or 240 V	230 V
L1 to ground	105 V	120 V	230 V
L2 to ground	105 V	120 V	0 V

a. In some European countries, there might not be a polarization.

Verifying the Safety Ground (Single Power Source)

Use this procedure to measure the voltage level between A0 and A1. It also verifies the voltage level between B0 and B1. Take measurements between ground pins. Refer to Figure 3-23 for ground reference points when performing these measurements.

Figure 3-23 Safety Ground Reference Check — Single Power Source

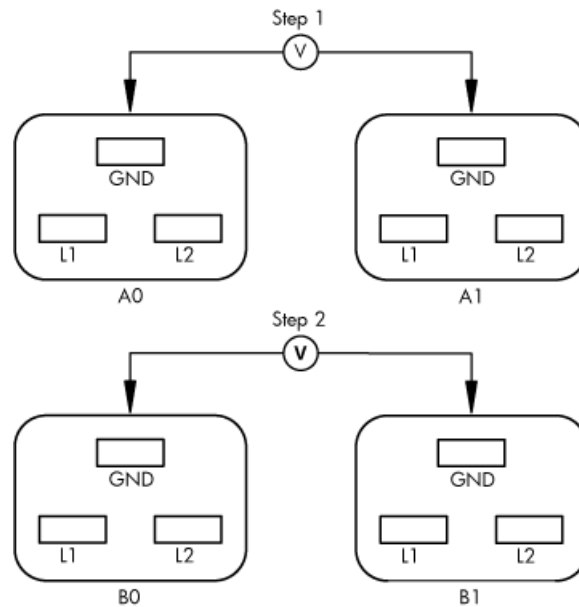

WARNING SHOCK HAZARD
Risk of shock hazard while testing primary power.
Use properly insulated probes.
Be sure to replace access cover when finished testing primary power.

Step 1. Measure the voltage between A0 and A1 as follows:

1. Take the AC voltage down to the lowest scale on the volt meter.

2. Insert the probe into the ground pin for A0.
3. Insert the other probe into the ground pin for A1.
4. Verify that the measurement is between 0-5 V AC.

If the measurement is 5 V or greater, escalate the situation. Do not attempt to plug the power cord into the server cabinet.

Step 2. Measure the voltage between B0 and B1 as follows:

1. Take the AC voltage down to the lowest scale on the volt meter.
2. Insert the probe into the ground pin for B0.
3. Insert the other probe into the ground pin for B1.
4. Verify that the measurement is between 0-5 V AC.

If the measurement is 5 V or greater, escalate the situation. Do not attempt to plug the power cord into the server cabinet.

Verifying the Safety Ground (Dual Power Source)

Use this procedure to measure the voltage level between A0 and A1, between B0 and B1, between A0 and B0, and between A1 and B1. Take all measurements between ground pins. Refer to Figure 3-24 for ground reference points when performing these measurements.

Figure 3-24 Safety Ground Reference Check — Dual Power Source

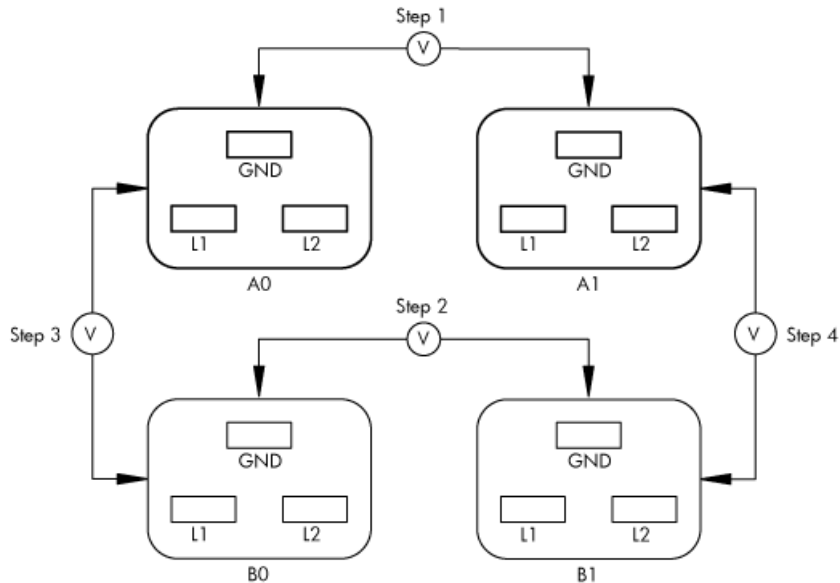

WARNING SHOCK HAZARD
Risk of shock hazard while testing primary power.
Use properly insulated probes.
Be sure to replace access cover when finished testing primary power.

Step 1. Measure the voltage between A0 and A1 as follows:

1. Take the AC voltage down to the lowest scale on the volt meter.
2. Insert the probe into the ground pin for A0.
3. Insert the other probe into the ground pin for A1.
4. Verify that the measurement is between 0-5 V AC.

If the measurement is 5 V or greater, escalate the situation. Do not attempt to plug the power cord into the server cabinet.

Step 2. Measure the voltage between B0 and B1 as follows:

1. Take the AC voltage down to the lowest scale on the volt meter.
2. Insert the probe into the ground pin for B0.
3. Insert the other probe into the ground pin for B1.
4. Verify that the measurement is between 0-5 V AC.

If the measurement is 5 V or greater, escalate the situation. Do not attempt to plug the power cord into the server cabinet.

Step 3. Measure the voltage between A0 and B0 as follows:

1. Take the AC voltage down to the lowest scale on the volt meter.
2. Insert the probe into the ground pin for A0.
3. Insert the other probe into the ground pin for B0.
4. Verify that the measurement is between 0-5 V AC.

If the measurement is 5 V or greater, escalate the situation. Do not attempt to plug the power cord into the server cabinet.

Step 4. Measure the voltage between A1 and B1 as follows:

1. Take the AC voltage down to the lowest scale on the volt meter.
2. Insert the probe into the ground pin for A1.
3. Insert the other probe into the ground pin for B1.
4. Verify that the measurement is between 0-5 V AC.

If the measurement is 5 V or greater, escalate the situation. Do not attempt to plug the power cord into the server cabinet.

Voltage Check (Additional Procedure)

The voltage check ensures that all phases (and neutral, for international systems) are connected correctly to the cabinet and that the AC input voltage is within limits.

Perform this procedure if the previous voltage check procedure did not yield the expected results.

NOTE If you use an uninterruptible power supply (UPS), refer to applicable UPS documentation for information on connecting the server and checking the UPS output voltage. UPS user documentation is shipped with the UPS. Documentation is also available at:

<http://www.hp.com/racksolutions>

Step 1. Verify that site power is **OFF**.

Step 2. Open the site circuit breakers.

Step 3. Verify that the receptacle ground connector is connected to ground. Refer to Figure 3-25 for connector details.

Step 4. Set the site power circuit breaker to **ON**.

Figure 3-25 Wall Receptacle Pinouts

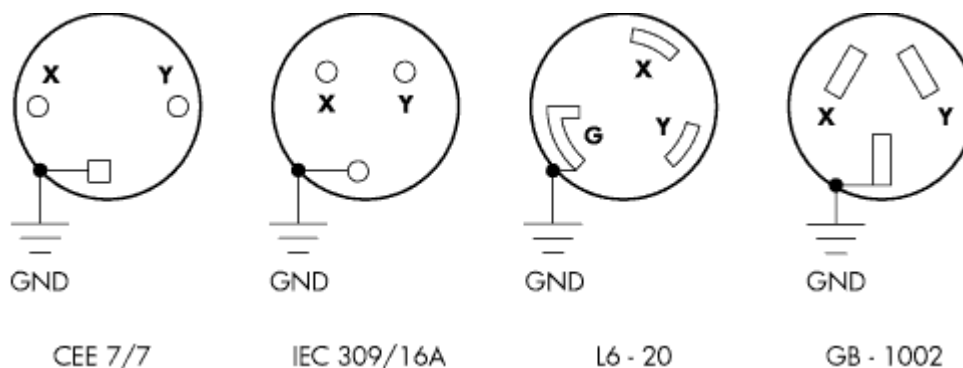

Step 5. Verify that the voltage between receptacle pins X and Y is between 200–240 V AC.

WARNING SHOCK HAZARD
Risk of shock hazard while testing primary power.
Use properly insulated probes.
Be sure to replace access cover when finished testing primary power.

Step 6. Set the site power circuit breaker to **OFF**.

Step 7. Route and connect the server power connector to the site power receptacle.

1. For locking type receptacles, line up the key on the plug with the groove in the receptacle.
2. Push the plug into the receptacle and rotate to lock the connector in place.

WARNING Do not set site AC circuit breakers serving the processor cabinets to **ON** before verifying that the cabinet has been wired into the site AC power supply correctly. Failure to do so can result in injury to personnel or damage to equipment when AC power is applied to the cabinet.

Step 8. Set the site AC circuit breaker to **ON**.

Step 9. Set the server power to **ON**.

Step 10. Check that the indicator light on each power supply is lit.

Connecting AC Input Power

The server can receive AC input from two different AC power sources. If two separate power sources are available, the server can be plugged into the separate power sources, increasing system reliability if one power source fails. The main power source is defined to be A0 and A1. The redundant power source is defined to be B0 and B1. See Figure 3-26 for the AC power input label scheme.

NOTE When running the server with a single power source, use either A0 and A1 or B0 and B1. All other combinations are not supported. Either combination requires two power cords.

Figure 3-26 AC Power Input Labeling

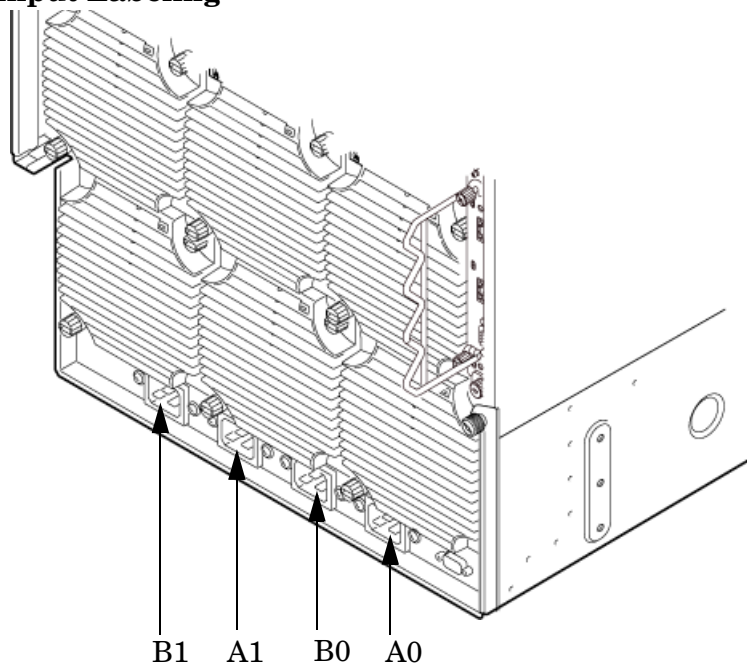

The power distribution for the bulk power supplies is as follows:

- A0 input provides power to BPS 0, BPS 1, and BPS 2
- A1 input provides power to BPS 3, BPS 4, and BPS 5
- B0 input provides power to BPS 0, BPS 1, and BPS 2

- B1 input provides power to BPS 3, BPS 4, and BPS 5

For information on how input power cords supply power to each BPS, refer to Figure 3-27.

Figure 3-27 Distribution of Input Power for Each Bulk Power Supply

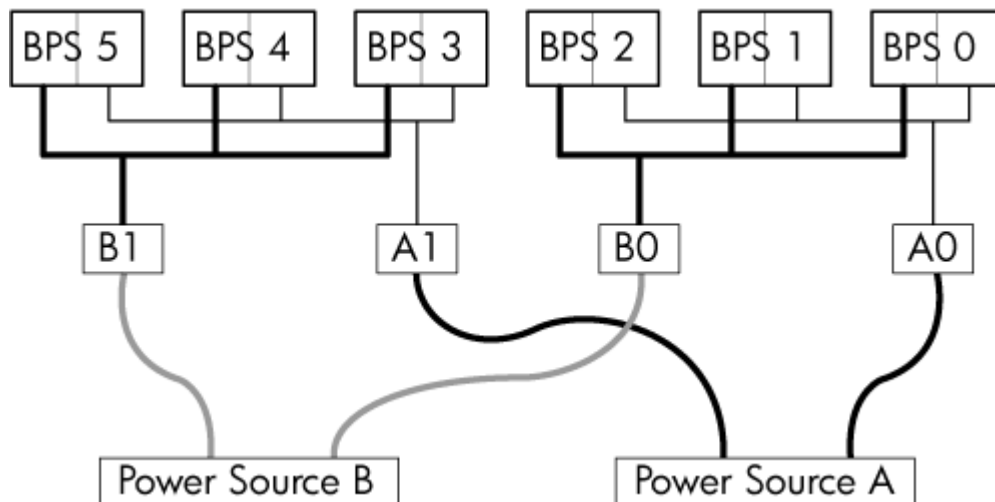

WARNING Voltage is present at various locations within the server whenever a power source is connected. This voltage is present even when the main power switch is in the off position. To completely remove power, all power cords must be removed from the server. Failure to observe this warning could result in personal injury or damage to equipment.

CAUTION Do not route data and power cables together in the same cable management arm.

Do not route data and power cables in parallel paths in close proximity to each other. The suggested minimum distance between the data and power cables is 3 inches (7.62 cm).

The power cord has current flowing through it, which creates a magnetic field. The potential to induce electromagnetic interference in the data cables exists, which can cause data corruption.

NOTE Label the AC power cords during the installation. One suggestion is to use tie wraps that have the flag molded into the tie wrap. The flag can be labeled using the appropriate two characters to represent the particular AC power input (for example, A0). Another suggestion would be to use color coded plastic bands. Use one color to represent the first pair A0/A1 and another color to represent the second pair B0/B1 (provided a second power source is available at the customer site).

The server can accommodate a total of six BPSs. N+1 capability means that the server has an adequate number of BPS installed. If one BPS fails, enough power will still be supplied to the cell boards to keep the server partitions operational. Replace the failed BPS promptly to restore N+1 functionality.

A minimum of two BPS are required to bring up a single cell board installed in the server. There is no N+1 capability in this case. Refer to Table 3-5 for configurations of multiple cell boards using N+1.

Table 3-5 BPS-to-Cell Board Configuration to Maintain N+1

Number of Cell Boards Installed in the Server	Number of Operational BPS Installed to Maintain N+1 Functionality
1	3
2	4
3	5
4	6

Applying Power to the Server

Observe the functionality of the server before attaching any LAN or serial cables, the system console, or any peripherals to the server. Then, after applying an active AC power source to the server, make the following observations at three different intervals, or points in time.

Interval One

The power has just been applied to the server, but the front panel **ON/OFF** switch is **OFF**. The front air intake fans will flash a dim red color, the bulk power supplies will flash amber and an amber light is present on the hard disk drives.

Interval Two

After the power has been plugged into the server for about 30 seconds, the standby power turns on and the front intake fan LED indicators turn solid green. The BPS will flash green and the amber light is still present on the hard disk drives. The front panel **ON/OFF** switch is **OFF** at this interval. Housekeeping power is up at this point.

Interval Three

With the **ON/OFF** switch on the front of the server set to **ON**, the intake fans spin up and become noticeably audible, while the fan LED indicator remains solid green. The BPS LED indicator turns a solid green, and the PCI backplane power supply LED indicators turn solid green. The hard disk drive LED turns green briefly and then the LED turns **OFF**.

Installing The Line Cord Anchor (rack mounted servers)

The line cord anchor is attached to the rear of the server when rack mounted. It provides a method to secure the line cords to the server preventing accidental removal of the cords from the server.

Four Cell Server Installation (rp8400, rp8420, rp8440, rx8620, rx8640)

There are pre-drilled holes and pre-installed captive nuts in the server chassis.

To install the line cord anchor

1. Align the line cord anchor thumbscrews with the corresponding captive nuts at the rear of the chassis. Refer to Figure 3-28, “Four Cell Line Cord Anchor (rp8400, rp8420, rp8440, rx8620, rx8640),”

Figure 3-28 Four Cell Line Cord Anchor (rp8400, rp8420, rp8440, rx8620, rx8640)

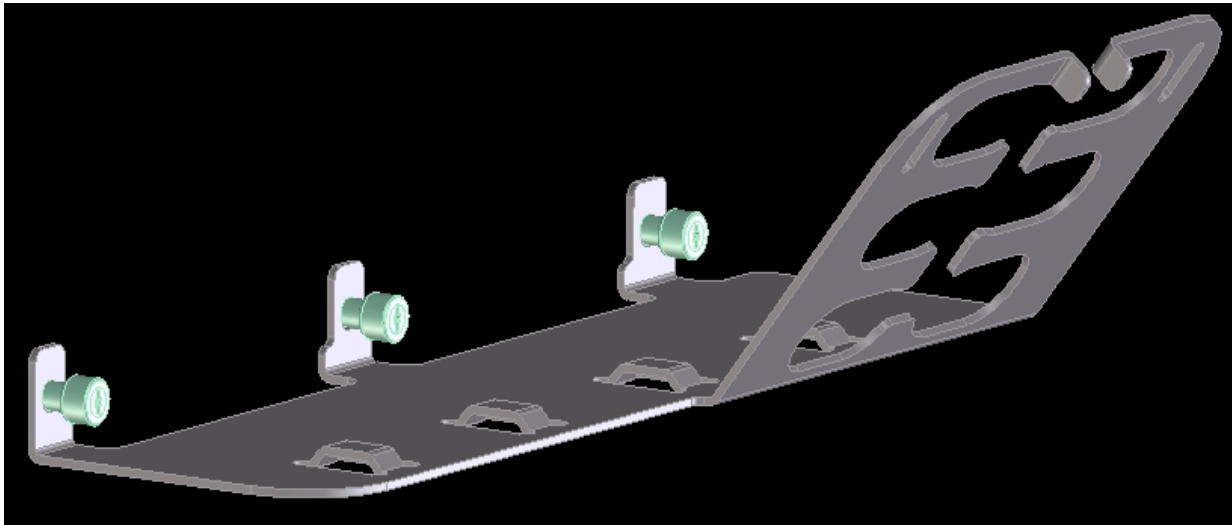

2. Tighten the captive thumbscrews to secure the line cord anchor to the chassis.
3. Weave the power cables through the line cord anchor. Leave enough slack that the plugs can be disconnected from the receptacles without removing the cords from the line cord anchor

4. Use the supplied Velcro straps to attach the cords to the anchor. Refer to Figure 3-29, “Line Cord Anchor and Velcro straps,”

Figure 3-29 Line Cord Anchor and Velcro straps

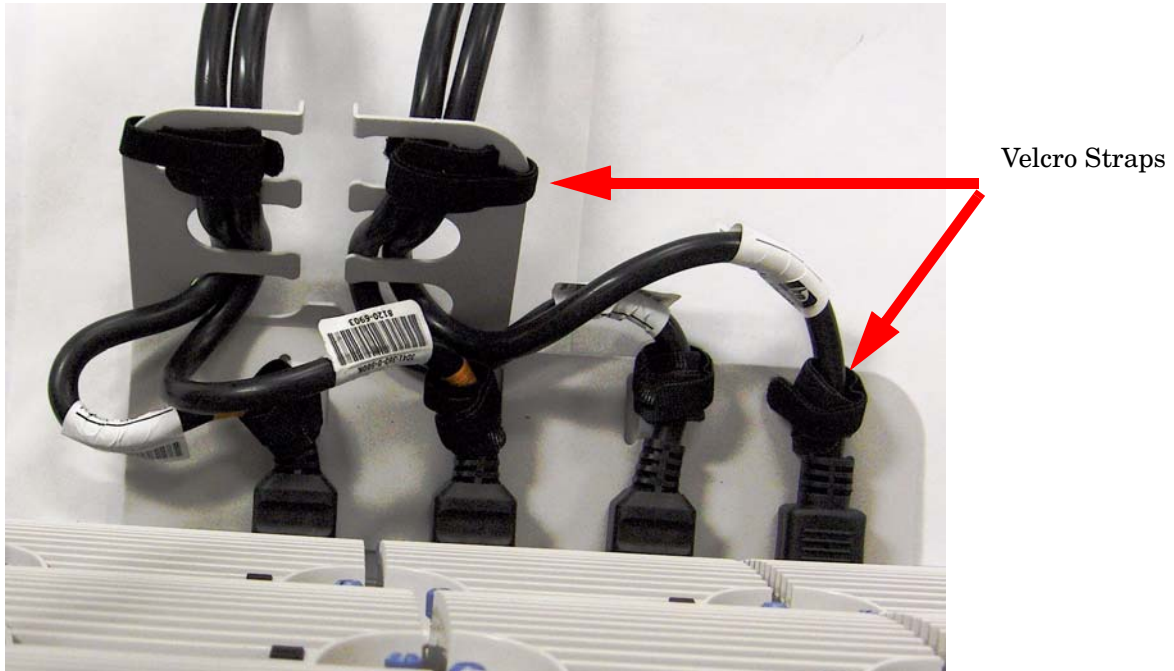

MP Core I/O Connections

Each HP server has at least one core I/O card installed. Each core I/O card has a management processor (MP). If two core I/O cards are installed, this allows for two partitions to be configured or enables core I/O redundancy in a single partition configuration. Each core I/O card is oriented vertically and accessed from the back of the server.

Use the core I/O board to update firmware, access the console, turn partition power on and off, and utilize other features of the system.

External connections to the core I/O board include the following:

- One Ultra 320 (320 MB/sec) 68-pin SCSI port for connection to external SCSI devices by a high-density cable interconnect (VHDCI) connector.
- One RJ-45 style 10Base-T/100Base-T/1000Base-T system LAN connector. This LAN uses standby power and is active when AC is present and the front panel power switch is OFF.
- One RJ-45 style 10Base-T/100Base-T MP LAN connector. This LAN uses standby power and is active when AC is present and the front panel power switch is OFF. This LAN is also active when the front power switch is ON.
- One DB-9 RS-232 connector which provides local console.

Internal connections for the core I/O board include the following:

- Two low voltage differential (LVD) internal SCSI buses for internal drives
- One single-ended (SE) internal SCSI bus for internal media.

Setting Up the Customer Engineer Tool (PC)

The CE Tool is usually a laptop. It allows communication with the management processor (MP) in the server. The MP monitors the activity of either a one-partition or a multiple-partition configuration.

During installation, communicating with the MP enables such tasks as:

- Verifying that the components are present and installed correctly
- Setting LAN IP addresses
- Shutting down cell board power

Establish communication with the MP by connecting the CE Tool to the local RS-232 port on the core I/O card.

Setting CE Tool Parameters

After powering on the CE Tool, ensure that the communications settings are as follows:

- 8/none (parity)
- 9600 baud
- None (Receive)
- None (Transmit)

If the CE Tool is a laptop using Reflection 1, check or change these communications settings using the following procedure:

Step 1. From the Reflection 1 Main screen, pull down the **Connection** menu and select **Connection Setup**.

Step 2. Select **Serial Port**.

Step 3. Select **Com1**.

Step 4. Check the settings and change, if required.

Go to **More Settings** to set Xon/Xoff. Click **OK** to close the More Settings window.

Step 5. Click **OK** to close the Connection Setup window.

Step 6. Pull down the **Setup** menu and select **Terminal** (under the **Emulation** tab).

Step 7. Select the VT100 HP terminal type.

Step 8. Click **Apply**.

This option is not highlighted if the terminal type you want is already selected.

Step 9. Click **OK**.

Connecting the CE Tool to the Local RS-232 Port on the MP

This connection enables direct communications with the MP. **Only one window can be created** on the CE Tool to monitor the MP. When enabled, it provides direct access to the MP and to any partition.

Use the following procedure to connect the CE Tool to the RS-232 Local port on the MP:

- Step 1.** Connect one end of a null modem cable (9-pin to 9-pin) (Part Number 5182-4794) to the **RS-232 Local** port on the core I/O card (the DB9 connector located at the bottom of the core I/O card). Refer to Figure 3-30.

Figure 3-30 LAN and RS-232 Connectors on the Core I/O Board

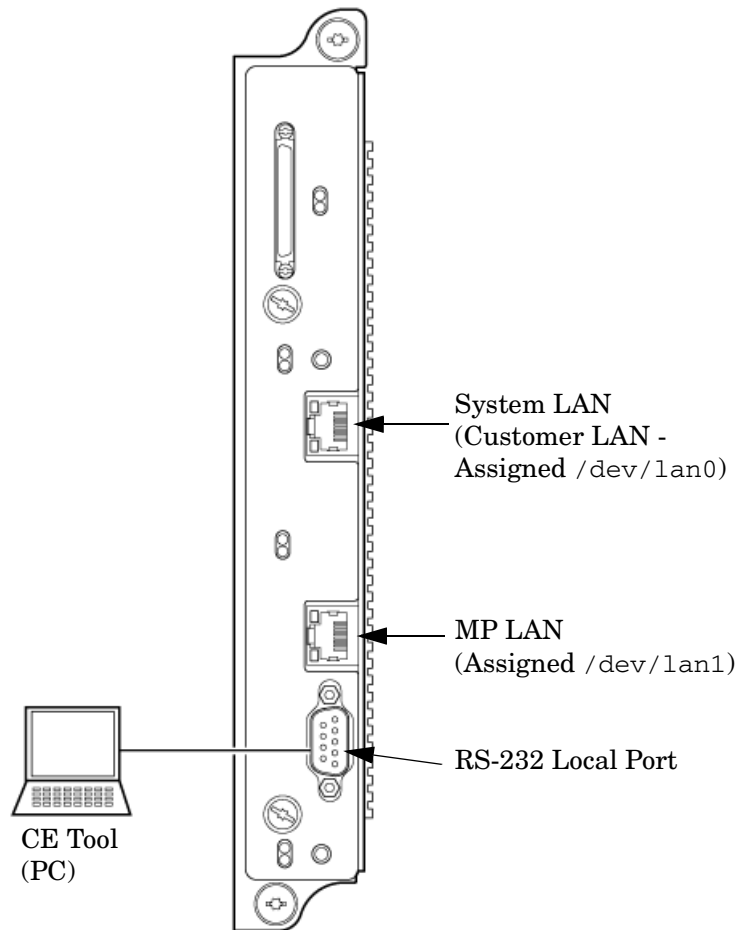

NOTE The ability to telnet to the MP LAN port is available once the MP is configured via the RS-232 Local port.

- Step 2.** Connect the other end of the RS-232 cable to the CE Tool.

Turning On Housekeeping Power and Logging In to the MP

After connecting the serial display device, the power to the server cabinet is ready to be supplied to get a login prompt for the management processor (MP). Connecting the power cords allows power to flow to the bulk power supplies (BPS) located at the front of the server cabinet, which in turn provides housekeeping power (HKP).

Before powering up the server cabinet for the first time:

Step 1. Verify that the AC voltage at the input source is within specifications for each server cabinet being installed.

Step 2. If not already done, power on the serial display device.

The preferred tool is the CE Tool running Reflection 1.

To power on the MP, set up a communications link, and log in to the MP:

Step 1. Apply power to the server cabinet.

On the front of the server, the MP Status LED will illuminate yellow until the MP is booted successfully. Once the MP is booted successfully, and no other cabinet faults exist, the LED will change to solid green. Refer to Figure 3-31.

Figure 3-31 Front Panel Display

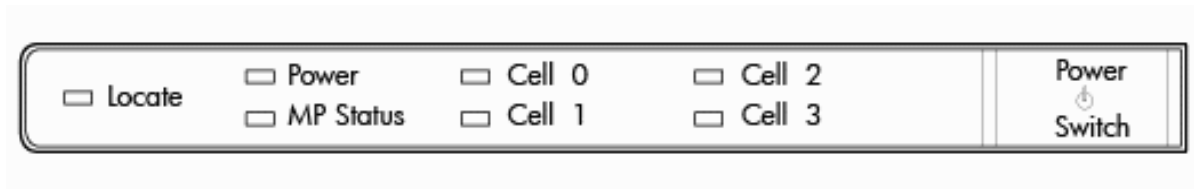

Step 2. Check the bulk power supply (BPS) LED for each BPS. Refer to Figure 3-32 for the LED location.

When on, the breakers distribute power to the BPS. AC power is present at the BPS:

- When power is first applied. The BPS LEDs will flash amber.
- After 30 seconds have elapsed. The flashing amber BPS LED for each BPS becomes a flashing green LED.

Figure 3-32 BPS LED Location

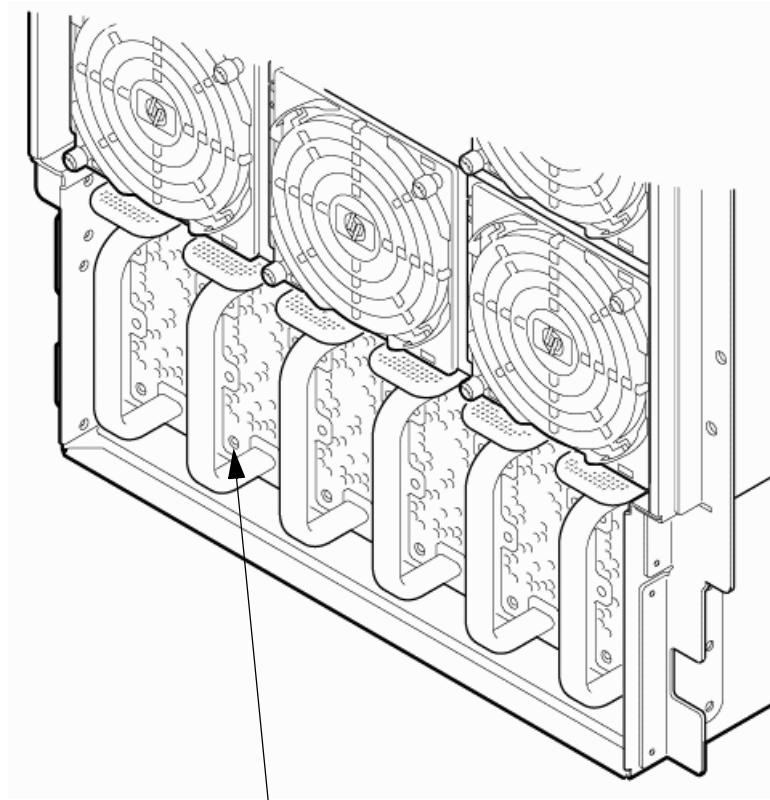

BPS LED Location

Step 3. Log in to the MP:

1. Enter `Admin` at the login prompt. (This term is case-sensitive.)

It takes a few moments for the `MP>` prompt to appear. If the `MP>` prompt does not appear, verify that the laptop serial device settings are correct: 8 bits, no parity, 9600 baud, and None for both Receive and Transmit. Then try again.

2. Enter `Admin` at the password prompt. (This term is case-sensitive.)

The MP Main Menu is displayed:

Figure 3-33 MP Main Menu

```
                Welcome to
            rx8640's Management Processor

MP MAIN MENU:

    CO: Consoles
    VFP: Virtual Front Panel
    CM: Command Menu
    CL: Console Logs
    SL: Show Event Logs
    FW: Firmware Update
    HE: Help
    X: Exit Connection

[metro-s] MP>
```

Configuring LAN Information for the MP

This section describes how to set and verify the server management processor (MP) LAN port information. LAN information includes the MP network name, the MP IP address, the subnet mask, and gateway address. This information is provided by the customer.

To set the MP LAN IP address:

Step 1. At the MP Main Menu prompt (MP>), enter `cm`.

NOTE If the Command Menu does not appear, enter `q` to return to the MP Main Menu, then enter `cm`.

Step 2. From the MP Command Menu prompt (MP>CM:), enter `lc` (for LAN configuration).

The screen displays the default values and asks if you want to modify them. It is a good idea to write down the information or log it to a file, because it may be required for future troubleshooting.

Enter `lc` and press the **Return** key. The `lc` command is displayed as shown in Figure 3-34.

Figure 3-34 The `lc` Command Screen

```
MP:CM> lc
```

This command modifies the LAN parameters.

Current configuration of MP customer LAN interface

```
MAC address   : 00:12:79:b4:03:1c
IP address    : 15.11.134.222    0x0f0b86de
Hostname      : metro-s
Subnet mask   : 255.255.248.0    0xffffffff800
Gateway       : 15.11.128.1     0x0f0b8001
Status        : UP and RUNNING
Link          : Connected 100Mb Half Duplex
```

```
Do you want to modify the configuration for the MP LAN? (Y/[N]) q
```

NOTE The value in the IP address field has been set at the factory. Obtain the LAN IP address from the customer.

Step 3. At the prompt, *Do you want to modify the configuration for the customer LAN?*, enter `Y`.

The current IP address is shown; then the following prompt is displayed: *Do you want to modify it? (Y/[N])*

Step 4. Enter `Y`.

Step 5. Enter the new IP address.

The customer provides this address.

Step 6. Confirm the new address.

Step 7. Enter the MP host name.

This is the host name for the MP customer LAN. The name can be up to 64 characters long and can include alpha numerics, -dash (-), under score (_), period (.), or a space (). HP recommends that the name be a derivative of the complex name, for example, `Acme.com_MP`.

Step 8. Enter the LAN parameters for Subnet mask and Gateway address.

This information comes from the customer.

When this step is completed, the system will indicate that the parameters have been updated and return to the MP Command Menu prompt (`MP:CM>`)

Step 9. To check the LAN parameters and status, enter the `ls` command at the MP Command Menu prompt (`MP:CM>`).

Step 10. A screen similar to Figure 3-35 will display allowing verification of the settings.

Figure 3-35The ls Command Screen

```
[metro-s] MP:CM> ls

Current configuration of MP customer LAN interface
MAC address   : 00:12:79:b4:03:02
IP address    : 15.99.49.26      0x0f63311a
Hostname      : metro-s
Subnet mask   : 255.255.248.0   0xfffff800
Gateway       : 15.99.49.254   0x0f6331fe
Status        : UP and RUNNING
```

To return to the MP Main menu, enter `ma`.

To exit the MP, enter `x` at the MP Main Menu.

Accessing the Management Processor via a Web Browser

Web browser access is an embedded feature of the management processor (MP). The Web browser enables access to the server via the LAN port on the core I/O card. MP configuration must be done from an ASCII console.

NOTE The MP has a separate LAN port from the system LAN port. It requires a separate LAN drop, IP address, and networking information from that of the port used by HP-UX.

Before starting this procedure, gather the following information:

- IP address for the MP LAN
- Subnet mask
- Gateway address
- Host name (this is used when messages are logged or printed)

To configure the LAN port for a Web browser, perform the following steps:

Step 1. Connect to the MP using a serial connection.

Step 2. Configure the MP LAN. Refer to “Configuring LAN Information for the MP”.

Step 3. Type `CM` to enter the Command Menu.

Step 4. Type `sa` at the `MP:CM>` prompt to display and set MP remote access.

Figure 3-36 Example sa Command

```
[metro-s] MP:CM> sa
```

This command displays and allows modification of access parameters.

```
T - Telnet access           : Enabled.  
H - SSH access             : Enabled.  
W - Web Console           : Enabled (SSL NOT active).  
N - Network Diagnostics   : Disabled.  
I - IPMI Lan access       : Disabled.  
S - SNMP                  : Enabled.
```

```
Select access mode to change (q to quit) : q
```

Step 5. Launch a Web browser on the same subnet using the IP address for the MP LAN port.

Step 6. Click anywhere on the Zoom In/Out title bar (Figure 3-37) to generate a full screen MP window.

Figure 3-37 Browser Window

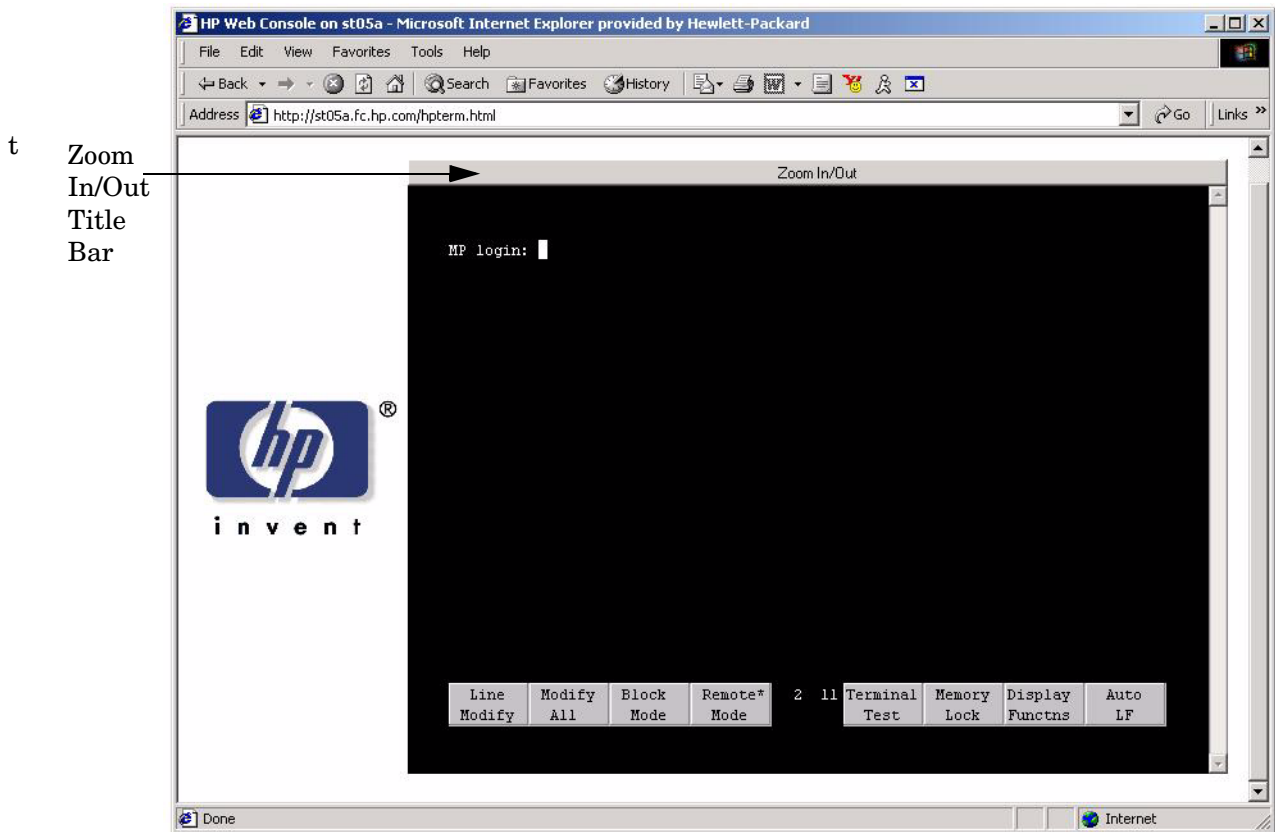

Step 7. Select the emulation type you want to use.

Step 8. Log in to the MP when the login window appears.

Access to the MP via a Web browser is now possible.

Verifying the Presence of the Cell Boards

To perform this activity, either connect to the management processor (MP) over the customer console or connect the CE Tool (laptop) to the RS-232 Local port on the MP.

After logging in to the MP, verify that the MP detects the presence of all the cells installed in the server cabinet. It is important for the MP to detect the cell boards. If it does not, the partitions will not boot.

To determine if the MP detects the cell boards:

Step 1. At the MP prompt, enter `cm`.

This displays the Command Menu. Among other things, the Command Menu enables you to view or modify the configuration and to look at utilities controlled by the MP.

To look at a list of the commands available, enter `he..` You might have to press **Enter** to see more than one screen of commands. Use the Pg Up and Pg Down keys to view the previous or next screen of commands. To exit the Help Menu, enter `q`.

Step 2. From the command prompt (`MP:CM>`), enter `du`.

The `du` command displays the MP Bus topology. A screen similar to the one in Figure 3-38 is displayed.

Figure 3-38The `du` Command Screen

```
MP:CM> du
The following MP bus devices were found:
+-----+-----+-----+-----+-----+
|Cab| MP | Sys |      | IO  | Bulk Pwr |
| # | M | S | Cells | Chassis | Supplies |
| 0 | * | * | * * * * | *   * | * * * * * |
+-----+-----+-----+-----+-----+
MP:CM> _
```

The column marked MP will contain an asterisk (*).

Step 3. Verify that there is an asterisk (*) for each of the cells installed in the server cabinet by comparing what is in the Cells column with the cells physically located inside the server cabinet.

Figure 3-38 shows that cells are installed in all the slots in cabinet 0, indicating that the server cabinet, contains cells physically located in all the slots.

Configuring AC Line Status

The MP utilities can detect if power is applied to each of the AC input cords for the server, by sampling the status of the bulk power supplies. During installation, use the following procedure to check the configuration for the AC line status and configure it to match the customer's environment.

- Step 1.** At the MP prompt, enter `cm`. This will display the Command Menu and enable you to view and configure various utilities controlled by the MP.
- Step 2.** From the command prompt (`MP:CM>`), enter `pwrgrd`. The `pwrgrd` command displays the current power configuration. This command can also be used to change the power grid configuration. A screen similar to the one in Figure 3-39 is displayed.

Figure 3-39 The `pwrgrd` Command Screen

```
[metro-s] MP:CM> pwrgrd

The current power configuration is: Single grid

Power grid configuration preference.

    1. Single grid
    2. Dual grid

    Select Option: 1

Power grid configuration set to single grid
```

- Step 3.** Verify that the power grid configuration is correct by examining the output from the `pwrgrd` command. The preceding power configuration indicates that both grid A and grid B have been configured.
- Step 4.** To change the configuration, select the proper response and enter the appropriate numeric value when `Select Option:` displays on the screen. If no change is desired, enter `q` and press the **Enter** key. After the value has been entered, the MP will respond and indicate that the change has taken effect.

Booting the Server

Power on the server either by pressing the power switch on the front panel or by using the `pe` command to power on the cabinet or complex at the management processor Command Menu.

If you are using a LAN crossover cable with the laptop, review server activity for each partition configured while the server powers on and boots. You can open Windows for the complex and for each partition. HP recommends that at least two windows be opened:

- Step 1.** A window showing all activity in the complex. Following the installation procedure in this document causes a window to be open at startup.

To display activity for the complex:

1. Open a separate Reflection window and connect to the MP.
2. From the MP Main Menu, select the VFP command with the s option.

Step 2. A window showing activity for a single partition.

To display activity for each partition as it powers on:

Step 1. Open a separate Reflection window and connect to the MP.

Step 2. Select the VFP command and select the desired partition to view.

There should be no activity on the screen at this point in the installation process.

NOTE You cannot open more than one window using a serial display device.

To power on the server:

Step 1. If a Server Expansion Unit is attached to the server, press both the server power switch and the SEU power switch. Alternatively, at the MP:CM> prompt, use the PE x command to power on the complex, or the PE t command for each cabinet. The following events occur:

- Power is applied to the server.
- Processor-dependent code (PDC) starts to run on each cell.
- The cell self-test executes.
- Hardware initializes for the server.
- Console communication is established.

Step 2. After the cell has joined the partition or after boot is blocked (BIB) is displayed at the Virtual Front Panel (VFP), return to the MP Main Menu by pressing **Ctrl+B**.

Step 3. Enter co to enter console mode.

Step 4. Enter the partition number of the partition to boot.

Step 5. Press **Enter**.

Selecting a Boot Partition Using the MP

At this point in the installation process, the hardware is set up, the MP is connected to the LAN, the AC and DC power have been turned on, and the self-test is completed. Now the configuration can be verified.

After the DC power on and the self-test is complete, use the MP to select a boot partition.

- Step 1.** From the MP Main Menu, enter `cm`.
- Step 2.** From the MP Command Menu, enter `bo`.
- Step 3.** Select the partition to boot. Partitions can be booted in any order.
- Step 4.** Return to the MP Main Menu by entering `ma` from the MP Command Menu.
- Step 5.** Enter the console by typing `co` at the MP Main Menu.

Exit the MP to return automatically to the Extensible Firmware Interface (EFI) Shell menu.

Verifying the System Configuration Using the EFI Shell

From the EFI main menu, enter the POSSE shell by entering `co`. Typing `help` will list all the command categories available in the shell:

- `configuration --` goes to the configuration menu, where system configuration can be reset, configured or viewed.
- `memory --` memory related commands.

Once the parameters have been verified, enter `x` to return to the EFI Main Menu.

Booting HP-UX Using the EFI Shell

If the Instant Ignition was ordered, HP-UX will have been installed in the factory at the Primary Path address. If HP-UX is at a path other than the Primary Path, do the following:

- Step 1.** Type `cm` to enter the Command Menu from the Main Menu.
- Step 2.** `MP:CM> bo` This command boots the selected partition.
Select a partition to boot:
- Step 3.** Return to the Main Menu: `MP:CM> ma`
- Step 4.** From the Main Menu, go to the Consoles Menu: `MP> co`
Select a partition number.
- Step 5.** Return to the Main Menu by pressing **Ctrl+B**.
- Step 6.** At the EFI Shell prompt, select the file system to boot. Generally this is `fs0`.
`Shell> fs0:`
- Step 7.** At the `fs0` prompt, type `hpux` to boot the HP-UX operating system:
`fs0:\> hpux`

NOTE If the partition fails to boot or if the server was shipped without Instant Ignition, booting from a DVD that contains the operating system and other necessary software might be required.

Adding Processors for HP Integrity rx8640 with Instant Capacity

The Instant Capacity program provides access to additional CPU resources beyond the amount that was purchased for the server. This provides the ability to activate additional CPU power for unexpected growth and unexpected spikes in workloads.

Internally, Instant Capacity systems physically have more CPUs, called Instant Capacity CPUs, than the number of CPUs actually purchased. These Instant Capacity CPUs reside in the purchased system, but they belong to HP and therefore are HP assets. A nominal “Right-To-Access Fee” is paid to HP for each Instant Capacity processor in the system. At any time, any number of Instant Capacity CPUs can be “activated.” Activating an Instant Capacity CPU automatically and instantaneously transforms the Instant Capacity CPU into an instantly ordered and fulfilled CPU upgrade that requires payment. After the Instant Capacity CPU is activated and paid for, it is no longer an Instant Capacity CPU, but is now an ordered and delivered CPU upgrade for the system.

The following list offers information needed to update to iCAP version 8.x:

- HP-UX HWEnable11i – Hardware Enablement Patches for HP-UX11i v2, June 2006
- B9073BA – B.11.23.08.00.00.95 – HP-UX iCOD Instant Capacity (iCAP)
- Kernel entry – `diag2` – module `diag2` best [413F2ED6]
- B8465BA – A.02.00.04 – HP WBEM Services for HP-UX
- NParProvider – B.11.23.01.03.00.06 – nPartition Provider

Current information on installing, configuring, and troubleshooting iCAP version 8.x is available at: <http://docs.hp.com/en/B9073-90129/index.html>.

Information on the latest release notes for iCAP version 8.x can be found at: <http://docs.hp.com/en/B9073-90134/index.html>.

NOTE Ensure that the customer is aware of the Instant Capacity email requirements. Refer to <http://docs.hp.com> for further details.

Installation Checklist

The checklist in Table 3-6 is an installation aid. Use it only after you have installed several systems by following the detailed procedures described in the body of this document. This checklist is a compilation of the tasks described in this document, and is organized as follows:

- | | |
|------------|-----------------------------------------------------------------------------------------------|
| Procedures | The procedures outlined in this document in order. |
| In-process | The portion of the checklist that allows you to comment on the current status of a procedure. |
| Completed | The final check to ensure that a step has been completed and comments. |

Major tasks are in **bold type**, subtasks are indented.

Table 3-6 Factory-Integrated Installation Checklist

Procedure		In-process		Completed	
		Initials	Comments	Initials	Comments
Obtain LAN information					
Verify site preparation					
	Site grounding verified				
	Power requirements verified				
Check inventory					
Inspect shipping containers for damage					
Unpack cabinet					
	Allow proper clearance				
	Cut polystrap bands				
	Remove cardboard top cap				
	Remove corrugated wrap from the pallet				
	Remove four bolts holding down the ramps and remove the ramps				
	Remove antistatic bag				
	Check for damage (exterior and interior)				
	Position ramps				
	Roll cabinet off ramp				
Unpack the peripheral cabinet (if ordered)					
Unpack other equipment					
Remove and dispose of packaging material					
Move cabinet and equipment to computer room					
Move cabinet into final position					
	Position cabinet next to each other (approx. 1/2 inch)				

Table 3-6 Factory-Integrated Installation Checklist (Continued) (Continued)

Procedure		In-process		Completed	
	Adjust leveling feet				
	Install anti tip plates				
	Inspect cables for proper installation				
Set up CE tool and connect to Remote RS-232 port on MP					
Apply power to cabinet (Housekeeping)					
Check power to BPSs					
Log in to MP					
Set LAN IP address on MP					
Connect customer console					
Set up network on customer console					
Verify LAN connection					
Verify presence of cells					
Power on cabinet (48 V)					
Verify system configuration and set boot parameters					
Set automatic system restart					
Boot partitions					
Configure remote login (if required).					
Verify remote link (if required).					
Install non-factory, integrated I/O cards (if required)					
	Select PCI card slot				
	Install PCI card				
	Verify installation				
Route cables using the cable management arm					
Install other peripherals (if required)					
Perform visual inspection and complete installation					

Table 3-6 Factory-Integrated Installation Checklist (Continued) (Continued)

Procedure	In-process		Completed	
Set up network services (if required)				
Enable Instant Capacity (if available)				
Final inspection of circuit boards				
Final inspection of cabling				
Area cleaned and debris and packing materials disposed of				
Tools accounted for				
Parts and other items disposed of				
Make entry in Gold Book (recommended)				
Customer acceptance and signoff (if required)				

4 Booting and Shutting Down the Operating System

This chapter presents procedures for booting an operating system (OS) on an nPartition (hardware partition) and procedures for shutting down the OS.

Operating Systems Supported on Cell-based HP Servers

HP supports nPartitions on cell-based HP 9000 servers and cell-based HP Integrity servers. The following list describes the OSes supported on cell-based servers based on the HP sx2000 chipset.

- HP 9000 servers have PA-RISC processors and include the following cell-based models based on based on the HP sx2000 chipset:
 - HP 9000 Superdome (SD16B, SD32B, and SD64B models)
 - HP rp8440
 - HP rp7440

These HP 9000 servers run HP-UX 11i Version 1 (B.11.11). Refer to “Booting and Shutting Down HP-UX” on page 128 for details on booting an OS on these servers.

- HP Integrity servers have Intel® Itanium® 2 processors and include the following cell-based models based on the HP sx2000 chipset:
 - HP Integrity Superdome (SD16B, SD32B, and SD64B models)
 - HP rx8640
 - HP rx7640

All HP Integrity servers based on the HP sx2000 chipset run the following OSes:

- HP-UX 11i Version 2 (B.11.23) — Refer to “Booting and Shutting Down HP-UX” on page 128 for details.
- Microsoft® Windows® Server 2003 — Refer to “Booting and Shutting Down Microsoft Windows” on page 145 for details.

HP Integrity servers based on the HP sx2000 chipset run the following OSes *only in nPartitions that have dual-core Intel® Itanium® 2 processors*:

- HP OpenVMS I64 8.3 — Supported only in nPartitions that have dual-core Intel® Itanium® 2 processors. Prior releases of OpenVMS I64 are not supported on servers based on the HP sx2000 chipset.

Refer to “Booting and Shutting Down HP OpenVMS I64” on page 140 for details.

- Red Hat Enterprise Linux 4 Update 4— On servers based on the HP sx2000 chipset, is supported only in nPartitions that have dual-core Intel® Itanium® 2 processors. Prior releases of Red Hat Enterprise Linux are not supported on servers based on the HP sx2000 chipset.

NOTE Red Hat Enterprise Linux 4 will be supported soon after the release of cell-based HP Integrity servers with the Intel® Itanium® 2 dual-core processor. It is not supported on these servers when they first release.

Refer to “Booting and Shutting Down Linux” on page 150 for details.

- SuSE Linux Enterprise Server 10 — On servers based on the HP sx2000 chipset, is supported only in nPartitions that have dual-core Intel® Itanium® 2 processors. Prior releases of SuSE Linux Enterprise Server are not supported on servers based on the HP sx2000 chipset.

NOTE SuSE Linux Enterprise Server 10 is supported on HP rx8640 servers, and will be supported on other cell-based HP Integrity servers with the Intel® Itanium® 2 dual-core processor (rx7640 and Superdome) soon after the release of those servers.

Refer to “Booting and Shutting Down Linux” on page 150 for details.

NOTE On servers based on the HP sx2000 chipset, each cell has a cell local memory (CLM) parameter, which determines how firmware may interleave memory residing on the cell. The supported and recommended CLM setting for the cells in an nPartition depends on the OS running in the nPartition. Some OSes support using CLM, and some do not. For details on CLM support for the OS you will boot in an nPartition, refer to the booting section for that OS.

System Boot Configuration Options

This section briefly discusses the system boot options you can configure on cell-based servers. You can configure boot options that are specific to each nPartition in the server complex.

HP 9000 Boot Configuration Options

On cell-based HP 9000 servers the configurable system boot options include boot device paths (PRI, HAA, and ALT) and the autoboot setting for the nPartition. To set these options from HP-UX, use the `setboot` command. From the BCH system boot environment, use the `PATH` command at the BCH Main Menu to set boot device paths, and use the `PATHFLAGS` command at the BCH Configuration menu to set autoboot options. For details, issue `HELP command` at the appropriate BCH menu, where `command` is the command for which you want help.

HP Integrity Boot Configuration Options

On cell-based HP Integrity servers, you must properly specify the ACPI configuration value, which affects the OS startup process and on some servers can affect the shutdown behavior. You also can configure boot device paths and the autoboot setting for the nPartition. The following list describes each configuration option:

- **Boot Options List**

The boot options list is a list of loadable items available for you to select from the EFI Boot Manager menu. Ordinarily, the boot options list includes the EFI Shell and one or more OS loaders.

The following example includes boot options for HP OpenVMS, Microsoft Windows, HP-UX, and the EFI Shell. The final item in the EFI Boot Manager menu, the Boot Configuration menu, is not a boot option. The Boot Configuration menu enables system configuration through a maintenance menu.

```
EFI Boot Manager ver 1.10 [14.61] Please select a boot option
```

```
HP OpenVMS 8.3
EFI Shell [Built-in]
Windows Server 2003, Enterprise
HP-UX Primary Boot: 4/0/1/1/0.2.0
Boot Option Maintenance Menu
```

```
Use ^ and v to change option(s). Use Enter to select an option
```

NOTE In some versions of EFI, the Boot Configuration menu is listed as the Boot Option Maintenance Menu.

To manage the boot options list for each system use the EFI Shell, the EFI Boot Configuration menu, or OS utilities.

At the EFI Shell, the `bcfg` command supports listing and managing the boot options list for all OSs except Microsoft Windows. On HP Integrity systems with Windows installed the `\MSUtil\nvrboot.efi` utility is provided for managing Windows boot options from the EFI Shell. On HP Integrity systems with OpenVMS installed, the `\efi\vms\vms_bcfg.efi` and `\efi\vms\vms_show` utilities are provided for managing OpenVMS boot options.

The EFI Boot Configuration menu provides the Add a Boot Option, Delete Boot Option(s), and Change Boot Order menu items. (If you must add an EFI Shell entry to the boot options list, use this method.)

To save and restore boot options, use the EFI Shell `variable` command. The variable `-save file` command saves the contents of the boot options list to the specified `file` on an EFI disk partition. The variable `-restore file` command restores the boot options list from the specified `file` that was previously saved. Details also are available by entering `help variable` at the EFI Shell.

OS utilities for managing the boot options list include the HP-UX `setboot` command and the HP OpenVMS `@SYS$MANAGER:BOOT_OPTIONS.COM` command.

The OpenVMS I64 installation and upgrade procedures assist you in setting up and validating a boot option for your system disk. HP recommends that you allow the procedure to do this. Alternatively, you can use the `@SYS$MANAGER:BOOT_OPTIONS.COM` command (also referred to as the OpenVMS I64 Boot Manager utility) to manage boot options for your system disk. The OpenVMS I64 Boot Manager (`BOOT_OPTIONS.COM`) utility is a menu-based utility and is easier to use than EFI. To configure OpenVMS I64 booting on Fibre Channel devices, you must use the OpenVMS I64 Boot Manager utility (`BOOT_OPTIONS.COM`). For more information on this utility and other restrictions, refer to the *HP OpenVMS for Integrity Servers Upgrade and Installation Manual*.

For details, refer to the following sections.

- To set HP-UX boot options refer to “Adding HP-UX to the Boot Options List” on page 128.
- To set OpenVMS boot options refer to “Adding HP OpenVMS to the Boot Options List” on page 140.
- To set Windows boot options refer to “Adding Microsoft Windows to the Boot Options List” on page 145.
- To set Linux boot options refer to “Adding Linux to the Boot Options List” on page 150.

• Hyper-Threading

nPartitions that have dual-core Intel® Itanium® 2 processors can support Hyper-Threading. Hyper-Threading provides the ability for processors to create a second virtual core that allows additional efficiencies of processing. For example, a dual-core processor with Hyper-Threading active can simultaneously run four threads.

The EFI Shell `cpuconfig` command can enable and disable Hyper-Threading for an nPartition whose processors support it. Recent releases of the nPartition Commands and Partition Manager also support Hyper-Threading.

Details of the `cpuconfig` command are given below and are available by entering `help cpuconfig` at the EFI Shell.

- `cpuconfig threads` — Reports Hyper-Threading status for the nPartition
- `cpuconfig threads on` — Enables Hyper-Threading for the nPartition. After enabling Hyper-Threading the nPartition must be reset for Hyper-Threading to be active.
- `cpuconfig threads off` — Disables Hyper-Threading for the nPartition. After disabling Hyper-Threading the nPartition must be reset for Hyper-Threading to be inactive

After enabling or disabling Hyper-Threading, the nPartition must be reset for the Hyper-Threading change to take effect. Use the EFI Shell `reset` command.

Enabled means that Hyper-Threading will be active on the next reboot of the nPartition. *Active* means that each processor core in the nPartition has a second virtual core that enables simultaneously running multiple threads.

• Autoboot Setting

You can configure the autoboot setting for each nPartition either by using the `autoboot` command at the EFI Shell, or by using the Set Auto Boot TimeOut menu item at the EFI Boot Option Maintenance menu.

To set autoboot from HP-UX, use the `setboot` command.

- **ACPI Configuration Value—HP Integrity Server OS Boot**

On cell-based HP Integrity servers you must set the proper ACPI configuration for the OS that will be booted on the nPartition.

To check the ACPI configuration value, issue the `acpiconfig` command with no arguments at the EFI Shell.

To set the ACPI configuration value, issue the `acpiconfig value` command at the EFI Shell, where *value* is either `default` or `windows`. Then reset the nPartition by issuing the `reset` EFI Shell command for the setting to take effect.

The ACPI configuration settings for the supported OSes are in the following list.

- **HP-UX ACPI Configuration: default**

On cell-based HP Integrity servers, to boot or install the HP-UX OS, you must set the ACPI configuration value for the nPartition to `default`.

For details, refer to “ACPI Configuration for HP-UX Must Be default” on page 130.

- **HP OpenVMS I64 ACPI Configuration: default**

On cell-based HP Integrity servers, to boot or install the HP OpenVMS I64 OS, you must set the ACPI configuration value for the nPartition to `default`.

For details, refer to “ACPI Configuration for HP OpenVMS I64 Must Be default” on page 142.

- **Windows ACPI Configuration: windows**

On cell-based HP Integrity servers, to boot or install the Windows OS, you must set the ACPI configuration value for the nPartition to `windows`.

For details, refer to “ACPI Configuration for Windows Must Be windows” on page 147.

- **Red Hat Enterprise Linux ACPI Configuration: default**

On cell-based HP Integrity servers, to boot or install the Red Hat Enterprise Linux OS, you must set the ACPI configuration value for the nPartition to `default`.

For details, refer to “ACPI Configuration for Red Hat Enterprise Linux Must Be default” on page 152.

- **SuSE Linux Enterprise Server ACPI Configuration: default**

On cell-based HP Integrity servers, to boot or install the SuSE Linux Enterprise Server OS, you must set the ACPI configuration value for the nPartition to `default`.

For details, refer to “ACPI Configuration for SuSE Linux Enterprise Server Must Be default” on page 153.

- **ACPI Softpowerdown Configuration—OS Shutdown Behavior**

On HP rx7620, rx7640, rx8620, and rx8640 servers, you can configure the nPartition behavior when an OS is shut down and halted. The two options are to have hardware power off when the OS is halted, or to have the nPartition be made inactive (all cells are in a boot-is-blocked state). The normal OS shutdown behavior on these servers depends on the ACPI configuration for the nPartition.

You can run the `acpiconfig` command with no arguments to check the current ACPI configuration setting; however, softpowerdown information is displayed only when different from normal behavior.

To change the nPartition behavior when an OS is shut down and halted, use either the `acpiconfig enable softpowerdown` EFI Shell command or the `acpiconfig disable softpowerdown` command, and then reset the nPartition to make the ACPI configuration change take effect.

— **acpiconfig enable softpowerdown**

When set on HP rx7620, rx7640, rx8620, and rx8640 servers, `acpiconfig enable softpowerdown` causes nPartition hardware to be powered off when the OS issues a shutdown for reconfiguration command (for example, `shutdown -h` or `shutdown /s`).

This is the normal behavior on HP rx7620, rx7640, rx8620, and rx8640 servers with a windows ACPI configuration setting.

When `softpowerdown` is enabled on HP rx7620, rx7640, rx8620, and rx8640 servers, if one nPartition is defined in the server, then halting the OS powers off the server cabinet, including all cells and I/O chassis. On HP rx7620, rx7640, rx8620, and rx8640 servers with multiple nPartitions, halting the OS from an nPartition with `softpowerdown` enabled causes only the resources on the local nPartition to be powered off.

To power on hardware that has been powered off, use the `PE` command at the management processor Command Menu.

— **acpiconfig disable softpowerdown**

When set on HP rx7620, rx7640, rx8620, and rx8640 servers, `acpiconfig disable softpowerdown` causes nPartition cells to remain at a boot-is-blocked state when the OS issues a shutdown for reconfiguration command (for example, `shutdown -h` or `shutdown /s`). In this case, an OS shutdown for reconfiguration makes the nPartition inactive.

This is the normal behavior on HP rx7620, rx7640, rx8620, and rx8640 servers with an ACPI configuration setting of `default`.

To make an inactive nPartition active, use the management processor `BO` command to boot the nPartition past the boot-is-blocked state.

• **Boot Modes on HP Integrity nPartitions: nPars and vPars Modes**

On cell-based HP Integrity servers, each nPartition can be configured in either of two boot modes:

— **nPars Boot Mode**

In nPars boot mode, an nPartition is configured to boot any single operating system in the standard environment. When an nPartition is in nPars boot mode, it cannot boot the vPars monitor and therefore does not support HP-UX virtual partitions.

— **vPars Boot Mode**

In vPars boot mode, an nPartition is configured to boot into the vPars environment. When an nPartition is in vPars boot mode, it can only boot the vPars monitor and therefore it only supports HP-UX virtual partitions and it does not support booting HP OpenVMS I64, Microsoft Windows, or other operating systems. On an nPartition in vPars boot mode, HP-UX can boot only within a virtual partition (from the vPars monitor) and cannot boot as a standalone, single operating system in the nPartition.

CAUTION An nPartition on an HP Integrity server cannot boot HP-UX virtual partitions when in nPars boot mode. Likewise, an nPartition on an HP Integrity server cannot boot an operating system outside of a virtual partition when in vPars boot mode.

To display or set the boot mode for an nPartition on a cell-based HP Integrity server, use any of the following tools as appropriate. Refer to *Installing and Managing HP-UX Virtual Partitions (vPars)*, Sixth Edition, for details, examples, and restrictions.

— `parconfig` EFI shell command

The `parconfig` command is a built-in EFI shell command. Refer to the `help parconfig` command for details.

— `\EFI\HPUX\vparconfig` EFI shell command

The `vparconfig` command is delivered in the `\EFI\HPUX` directory on the EFI system partition of the disk where HP-UX virtual partitions has been installed on a cell-based HP Integrity server. For usage details, enter the `vparconfig` command with no options.

— `vparsenv` HP-UX command

On cell-based HP Integrity servers only, the `vparsenv` HP-UX command is installed on HP-UX 11iv2 (B.11.23) systems that have the HP-UX virtual partitions software. Refer to *vparsenv* (1m) for details.

NOTE

On HP Integrity servers, nPartitions that do not have the `parconfig` EFI shell command do not support virtual partitions and are effectively in nPars boot mode.

HP recommends that you do not use the `parconfig` EFI shell command and instead use the `\EFI\HPUX\vparconfig` EFI shell command to manage the boot mode for nPartitions on cell-based HP Integrity servers.

Refer to *Installing and Managing HP-UX Virtual Partitions (vPars)*, Sixth Edition, for details.

Booting and Shutting Down HP-UX

This section presents procedures for booting and shutting down HP-UX on cell-based HP servers and a procedure for adding HP-UX to the boot options list on HP Integrity servers.

- To determine whether the cell local memory (CLM) configuration is appropriate for HP-UX, refer to “HP-UX Support for Cell Local Memory” on page 128.
- To add an HP-UX entry to the nPartition boot options list on an HP Integrity server, refer to “Adding HP-UX to the Boot Options List” on page 128.
- To boot HP-UX, refer to “Booting HP-UX” on page 129.
- To shut down HP-UX, refer to “Shutting Down HP-UX” on page 138.

HP-UX Support for Cell Local Memory

On servers based on the HP sx2000 chipset, each cell has a cell local memory (CLM) parameter, which determines how firmware interleaves memory residing on the cell.

IMPORTANT HP-UX 11i Version 2 (B.11.23) supports using CLM. The optimal CLM settings for HP-UX B.11.23 depend on the applications and workload the OS is running.

To check CLM configuration details from an OS, use Partition Manager or the `parstatus` command. For example, the `parstatus -v -c#` command and `parstatus -v -p#` command report the CLM amount requested and CLM amount allocated for the specified cell (`-c#`, where `#` is the cell number) or the specified nPartition (`-p#`, where `#` is the nPartition number). For details, refer to the *HP System Partitions Guide* or the Partition Manager Web site (<http://docs.hp.com/en/PARMGR2/>).

To display CLM configuration details from the EFI Shell on a cell-based HP Integrity server, use the `info mem` command. If the amount of noninterleaved memory reported is less than 512 MB, then no CLM is configured for any cells in the nPartition (and the indicated amount of noninterleaved memory is used by system firmware). If the `info mem` command reports more than 512 MB of noninterleaved memory, then use Partition Manager or the `parstatus` command to confirm the CLM configuration details.

To set the CLM configuration, use Partition Manager or the `parmodify` command. For details, refer to the *HP System Partitions Guide* or the Partition Manager Web site (<http://docs.hp.com/en/PARMGR2/>).

Adding HP-UX to the Boot Options List

This section describes how to add an HP-UX entry to the system boot options list.

You can add the `\EFI\HPUX\HPUX.EFI` loader to the boot options list from the EFI Shell or EFI Boot Configuration menu (or in some versions of EFI, the Boot Option Maintenance Menu).

See “Boot Options List” on page 123 for additional information about saving, restoring, and creating boot options.

NOTE On HP Integrity servers, the OS installer automatically adds an entry to the boot options list.

Adding an HP-UX Boot Option

This procedure adds an HP-UX item to the boot options list from the EFI Shell.

To add an HP-UX boot option when logged in to HP-UX, use the `setboot` command. For details, refer to the *setboot* (1M) manpage.

Step 1. Access the EFI Shell environment.

Log in to the management processor, and enter `CO` to access the system console.

When accessing the console, confirm that you are at the EFI Boot Manager menu (the main EFI menu). If you are at another EFI menu, select the Exit option from the submenus until you return to the screen with the EFI Boot Manager heading.

From the EFI Boot Manager menu, select the EFI Shell menu option to access the EFI Shell environment.

Step 2. Access the EFI System Partition for the device from which you want to boot HP-UX (`fsX`: where *X* is the file system number).

For example, enter `fs2`: to access the EFI System Partition for the bootable file system number 2. The EFI Shell prompt changes to reflect the file system currently accessed.

The full path for the HP-UX loader is `\EFI\HPUX\HPUX.EFI`, and it should be on the device you are accessing.

Step 3. At the EFI Shell environment, use the `bcfg` command to manage the boot options list.

The `bcfg` command includes the following options for managing the boot options list:

- `bcfg boot dump` — Display all items in the boot options list for the system.
- `bcfg boot rm #` — Remove the item number specified by *#* from the boot options list.
- `bcfg boot mv #a #b` — Move the item number specified by *#a* to the position specified by *#b* in the boot options list.
- `bcfg boot add # file.efi "Description"` — Add a new boot option to the position in the boot options list specified by *#*. The new boot option references *file.efi* and is listed with the title specified by *Description*.

For example, `bcfg boot add 1 \EFI\HPUX\HPUX.EFI "HP-UX 11i"` adds an HP-UX 11i item as the first entry in the boot options list.

Refer to the `help bcfg` command for details.

Step 4. Exit the console and management processor interfaces if you are finished using them.

To exit the EFI environment press **^B (Control+B)**; this exits the system console and returns to the management processor Main Menu. To exit the management processor, enter `X` at the Main Menu.

Booting HP-UX

This section describes the following methods of booting HP-UX:

- “Standard HP-UX Booting” on page 130 — The standard ways to boot HP-UX. Typically, this results in booting HP-UX in multiuser mode.
- “Single-User Mode HP-UX Booting” on page 134 — How to boot HP-UX in single-user mode.
- “LVM-Maintenance Mode HP-UX Booting” on page 136 — How to boot HP-UX in LVM-maintenance mode.

Refer to “Shutting Down HP-UX” on page 138 for details on shutting down the HP-UX OS.

CAUTION ACPI Configuration for HP-UX Must Be default

On cell-based HP Integrity servers, to boot the HP-UX OS, an nPartition ACPI configuration value must be set to default.

At the EFI Shell interface, enter the `acpiconfig` command with no arguments to list the current ACPI configuration. If the `acpiconfig` value is not set to default, then HP-UX cannot boot. In this situation you must reconfigure `acpiconfig`; otherwise, booting will be interrupted with a panic when the HP-UX kernel is launched.

To set the ACPI configuration for HP-UX:

1. At the EFI Shell interface, enter the `acpiconfig default` command.
2. Enter the `reset` command for the nPartition to reboot with the proper (default) configuration for HP-UX.

Standard HP-UX Booting

This section describes how to boot HP-UX on cell-based HP 9000 servers and cell-based HP Integrity servers.

- On HP 9000 servers, to boot HP-UX refer to “HP-UX Booting (BCH Menu)” on page 130.
- On HP Integrity servers, to boot HP-UX use either of the following procedures:
 - “HP-UX Booting (EFI Boot Manager)” on page 132
 - “HP-UX Booting (EFI Shell)” on page 132

HP-UX Booting (BCH Menu)

From the BCH Menu, use the `BOOT` command to boot the HP-UX OS. The BCH Menu is available only on HP 9000 servers.

Step 1. Access the BCH Main Menu for the nPartition on which you want to boot HP-UX.

Log in to the management processor, and enter `CO` to access the Console list. Select the nPartition console. When accessing the console, confirm that you are at the BCH Main Menu (the `Main Menu: Enter command or menu>` prompt). If you are at a BCH menu other than the Main Menu, then enter `MA` to return to the BCH Main Menu.

Step 2. Choose which device to boot.

From the BCH Main Menu, use the `PATH` command to list any boot path variable settings. The primary (PRI) boot path normally is set to the main boot device for the nPartition. You also can use the `SEARCH` command to find and list potentially bootable devices for the nPartition.

```
Main Menu: Enter command or menu > PATH

    Primary Boot Path:  0/0/2/0/0.13
                       0/0/2/0/0.d      (hex)

    HA Alternate Boot Path:  0/0/2/0/0.14
                           0/0/2/0/0.e      (hex)

    Alternate Boot Path:  0/0/2/0/0.0
```

```
0/0/2/0/0.0    (hex)
```

```
Main Menu: Enter command or menu >
```

Step 3. Boot the device by using the `BOOT` command from the BCH interface.

You can issue the `BOOT` command in any of the following ways:

- **BOOT**

Issuing the `BOOT` command with no arguments boots the device at the primary (PRI) boot path.

- **BOOT *bootvariable***

This command boots the device indicated by the specified boot path, where *bootvariable* is the PRI, HAA, or ALT boot path.

For example, `BOOT PRI` boots the primary boot path.

- **BOOT LAN INSTALL or BOOT LAN.*ip-address* INSTALL**

The `BOOT...INSTALL` commands boot HP-UX from the default HP-UX install server or from the server specified by *ip-address*.

- **BOOT *path***

This command boots the device at the specified *path*. You can specify the *path* in HP-UX hardware path notation (for example, 0/0/2/0/0.13) or in path label format (for example, P0 or P1).

If you specify the *path* in path label format, then *path* refers to a device path reported by the last `SEARCH` command.

After you issue the `BOOT` command, the BCH interface prompts you to specify whether you want to stop at the ISL prompt.

To boot the `/stand/vmunix` HP-UX kernel from the device without stopping at the ISL prompt, enter `n` to automatically proceed past ISL and execute the contents of the `AUTO` file on the chosen device. (By default the `AUTO` file is configured to load `/stand/vmunix`.)

```
Main Menu: Enter command or menu > BOOT PRI
```

```
Primary Boot Path: 0/0/1/0/0.15
```

```
Do you wish to stop at the ISL prompt prior to booting? (y/n) >> n
```

```
ISL booting hpx
```

```
Boot
: disk(0/0/1/0/0.15.0.0.0.0.0;0)/stand/vmunix
```

To boot an HP-UX kernel other than `/stand/vmunix`, or to boot HP-UX in single-user or LVM-maintenance mode, stop at the ISL prompt and specify the appropriate arguments to the `hpx` loader.

Step 4. Exit the console and management processor interfaces if you are finished using them.

To exit the BCH environment, press **^B (Control+B)**; this exits the nPartition console and returns to the management processor Main Menu. To exit the management processor, enter `x` at the Main Menu.

HP-UX Booting (EFI Boot Manager)

From the EFI Boot Manager menu, select an item from the boot options list to boot HP-UX using that boot option. The EFI Boot Manager is available only on HP Integrity servers.

Refer to “ACPI Configuration for HP-UX Must Be default” on page 130 for required configuration details.

- Step 1.** Access the EFI Boot Manager menu for the nPartition on which you want to boot HP-UX.

Log in to the management processor, and enter `CO` to access the Console list. Select the nPartition console.

When accessing the console, confirm that you are at the EFI Boot Manager menu (the main EFI menu). If you are at another EFI menu, select the Exit option from the submenus until you return to the screen with the EFI Boot Manager heading.

- Step 2.** At the EFI Boot Manager menu, select an item from the boot options list.

Each item in the boot options list references a specific boot device and provides a specific set of boot options or arguments to be used when booting the device.

- Step 3.** Press **Enter** to initiate booting using the chosen boot option.

- Step 4.** Exit the console and management processor interfaces if you are finished using them.

To exit the EFI environment, press **^B (Control+B)**; this exits the nPartition console and returns to the management processor Main Menu. To exit the management processor, enter `X` at the Main Menu.

HP-UX Booting (EFI Shell)

From the EFI Shell environment, to boot HP-UX on a device first access the EFI System Partition for the root device (for example `fs0:`) and then enter `HPUX` to initiate the loader. The EFI Shell is available only on HP Integrity servers.

Refer to “ACPI Configuration for HP-UX Must Be default” on page 130 for required configuration details.

- Step 1.** Access the EFI Shell environment for the nPartition on which you want to boot HP-UX.

Log in to the management processor, and enter `CO` to access the Console list. Select the nPartition console.

When accessing the console, confirm that you are at the EFI Boot Manager menu (the main EFI menu). If you are at another EFI menu, select the Exit option from the submenus until you return to the screen with the EFI Boot Manager heading.

From the EFI Boot Manager menu, select the EFI Shell menu option to access the EFI Shell environment.

- Step 2.** At the EFI Shell environment, issue the `acpiconfig` command to list the current ACPI configuration for the local nPartition.

On cell-based HP Integrity servers, to boot the HP-UX OS, an nPartition ACPI configuration value must be set to `default`. If the `acpiconfig` value is not set to `default`, then HP-UX cannot boot; in this situation you must reconfigure `acpiconfig` or booting will be interrupted with a panic when launching the HP-UX kernel.

To set the ACPI configuration for HP-UX:

- a. At the EFI Shell interface enter the `acpiconfig default` command.
- b. Enter the `reset` command for the `nPartition` to reboot with the proper (default) configuration for HP-UX.

Step 3. At the EFI Shell environment, issue the `map` command to list all currently mapped bootable devices.

The bootable file systems of interest typically are listed as `fs0:`, `fs1:`, and so on.

Step 4. Access the EFI System Partition for the device from which you want to boot HP-UX (`fsX:` where `X` is the file system number).

For example, enter `fs2:` to access the EFI System Partition for the bootable file system number 2. The EFI Shell prompt changes to reflect the file system currently accessed.

The file system number can change each time it is mapped (for example, when the `nPartition` boots, or when the `map -r` command is issued).

Step 5. When accessing the EFI System Partition for the desired boot device, issue the `HPUX` command to initiate the `HPUX.EFI` loader on the device you are accessing.

The full path for the loader is `\EFI\HPUX\HPUX.EFI`. When initiated, `HPUX.EFI` references the `\EFI\HPUX\AUTO` file and boots HP-UX using the default boot behavior specified in the `AUTO` file.

You are given 10 seconds to interrupt the automatic booting of the default boot behavior. Pressing any key during this 10-second period stops the HP-UX boot process and enables you to interact with the `HPUX.EFI` loader. To exit the loader (the `HPUX>` prompt), enter `exit` (this returns you to the EFI Shell).

To boot the HP-UX OS, do not type anything during the 10-second period given for stopping at the `HPUX.EFI` loader.

```
Shell> map
Device mapping table
fs0  : Acpi(000222F0,269)/Pci(0|0)/Scsi(Pun8,Lun0)/HD(Part1,Sig72550000)
blk0 : Acpi(000222F0,269)/Pci(0|0)/Scsi(Pun8,Lun0)
blk1 : Acpi(000222F0,269)/Pci(0|0)/Scsi(Pun8,Lun0)/HD(Part1,Sig72550000)
blk2 : Acpi(000222F0,269)/Pci(0|0)/Scsi(Pun8,Lun0)/HD(Part2,Sig72550000)
blk3 : Acpi(000222F0,2A8)/Pci(0|0)/Scsi(Pun8,Lun0)
blk4 : Acpi(000222F0,2A8)/Pci(0|1)/Scsi(Pun2,Lun0)
```

```
Shell> fs0:
```

```
fs0:\> hpux
```

```
(c) Copyright 1990-2002, Hewlett Packard Company.
All rights reserved
```

```
HP-UX Boot Loader for IA64 Revision 1.723
```

```
Press Any Key to interrupt Autoboot
\efi\hpux\AUTO ==> boot vmunix
Seconds left till autoboot - 9
```

Step 6. Exit the console and management processor interfaces if you are finished using them.

To exit the EFI environment, press **^B (Control+B)**; this exits the `nPartition` console and returns to the management processor Main Menu. To exit the management processor, enter `X` at the Main Menu.

Single-User Mode HP-UX Booting

This section describes how to boot HP-UX in single-user mode on cell-based HP 9000 servers and cell-based HP Integrity servers.

- On HP 9000 servers, to boot HP-UX in single-user mode, refer to “Single-User Mode HP-UX Booting (BCH Menu)” on page 134.
- On HP Integrity servers, to boot HP-UX in single-user mode, refer to “Single-User Mode HP-UX Booting (EFI Shell)” on page 135.

Single-User Mode HP-UX Booting (BCH Menu)

From the BCH Menu, you can boot HP-UX in single-user mode by issuing the `BOOT` command, stopping at the ISL interface, and issuing `hpux` loader options. The BCH Menu is available only on HP 9000 servers.

- Step 1.** Access the BCH Main Menu for the nPartition on which you want to boot HP-UX in single-user mode.

Log in to the management processor, and enter `CO` to access the Console list. Select the nPartition console. When accessing the console, confirm that you are at the BCH Main Menu (the `Main Menu: Enter command or menu>` prompt). If you are at a BCH menu other than the Main Menu, then enter `MA` to return to the BCH Main Menu.

- Step 2.** Boot the desired device by using the `BOOT` command at the BCH interface, and specify that the nPartition stop at the ISL prompt prior to booting (reply `y` to the “stop at the ISL prompt” question).

```
Main Menu: Enter command or menu > BOOT 0/0/2/0/0.13
```

```
BCH Directed Boot Path: 0/0/2/0/0.13
```

```
Do you wish to stop at the ISL prompt prior to booting? (y/n) >> y
```

```
Initializing boot Device.
```

```
....
```

```
ISL Revision A.00.42 JUN 19, 1999
```

```
ISL>
```

- Step 3.** From the ISL prompt, issue the appropriate Secondary System Loader (`hpux`) command to boot the HP-UX kernel in the desired mode.

Use the `hpux` loader to specify the boot mode options and to specify which kernel to boot on the nPartition (for example, `/stand/vmunix`).

- To boot HP-UX in single-user mode:

```
ISL> hpux -is boot /stand/vmunix
```

Example 4-1 on page 135 shows output from this command.

- To boot HP-UX at the default run level:

```
ISL> hpux boot /stand/vmunix
```

To exit the ISL prompt and return to the BCH interface, issue the `EXIT` command instead of specifying one of the `hpux` loader commands.

Refer to the *hpux* (1M) manpage for a detailed list of *hpux* loader options.

Example 4-1 Single-User HP-UX Boot

```
ISL Revision A.00.42 JUN 19, 1999

ISL> hpux -is /stand/vmunix

Boot
: disk(0/0/2/0/0.13.0.0.0.0.0;0)/stand/vmunix
8241152 + 1736704 + 1402336 start 0x21a0e8

....

INIT: Overriding default level with level 's'

INIT: SINGLE USER MODE

INIT: Running /sbin/sh
#
```

Step 4. Exit the console and management processor interfaces if you are finished using them.

To exit the BCH environment, press **^B (Control+B)**; this exits the nPartition console and returns to the management processor Main Menu. To exit the management processor, enter **X** at the Main Menu.

Single-User Mode HP-UX Booting (EFI Shell)

From the EFI Shell environment, boot in single-user mode by stopping the boot process at the *HPUX.EFI* interface (the HP-UX Boot Loader prompt, *HPUX>*) by entering the *boot -is vmunix* command. The EFI Shell is available only on HP Integrity servers.

Refer to “ACPI Configuration for HP-UX Must Be default” on page 130 for required configuration details.

Step 1. Access the EFI Shell environment for the nPartition on which you want to boot HP-UX in single-user mode.

Log in to the management processor, and enter **CO** to access the Console list. Select the nPartition console.

When accessing the console, confirm that you are at the EFI Boot Manager menu (the main EFI menu). If you are at another EFI menu, select the Exit option from the submenus until you return to the screen with the EFI Boot Manager heading.

From the EFI Boot Manager menu, select the EFI Shell menu option to access the EFI Shell environment.

Step 2. Access the EFI System Partition for the device from which you want to boot HP-UX (*fsX*: where *X* is the file system number).

Step 3. When accessing the EFI System Partition for the desired boot device, issue the *HPUX* command to initiate the *\EFI\HPUX\HPUX.EFI* loader on the device you are accessing.

Step 4. Boot to the HP-UX Boot Loader prompt (*HPUX>*) by pressing any key within the 10 seconds given for interrupting the HP-UX boot process. You will use the *HPUX.EFI* loader to boot HP-UX in single-user mode in the next step.

After you press any key, the HPUX.EFI interface (the HP-UX Boot Loader prompt, HPUX>) is provided. For help using the HPUX.EFI loader, enter the help command. To return to the EFI Shell, enter exit.

```
fs0:\> hpux

(c) Copyright 1990-2002, Hewlett Packard Company.
All rights reserved

HP-UX Boot Loader for IA64  Revision 1.723

Press Any Key to interrupt Autoboot
\efi\hpux\AUTO ==> boot vmunix
Seconds left till autoboot - 9
```

[User Types a Key to Stop the HP-UX Boot Process and Access the HPUX.EFI Loader]

Type 'help' for help

HPUX>

Step 5. At the HPUX.EFI interface (the HP-UX Boot Loader prompt, HPUX>), enter the boot -is vmunix command to boot HP-UX (the /stand/vmunix kernel) in single-user (-is) mode.

```
HPUX> boot -is vmunix
> System Memory = 4063 MB
loading section 0
..... (complete)
loading section 1
..... (complete)
loading symbol table
loading System Directory(boot.sys) to MFS
....
loading MFSFILES Directory(bootfs) to MFS
.....
Launching /stand/vmunix
SIZE: Text:25953K + Data:3715K + BSS:3637K = Total:33306K

Console is on a Serial Device
Booting kernel...
```

Step 6. Exit the console and management processor interfaces if you are finished using them.

To exit the EFI environment, press **^B (Control+B)**; this exits the nPartition console and returns to the management processor Main Menu. To exit the management processor, enter X at the Main Menu.

LVM-Maintenance Mode HP-UX Booting

This section describes how to boot HP-UX in LVM-maintenance mode on cell-based HP 9000 servers and cell-based HP Integrity servers.

- On HP 9000 servers, to boot HP-UX in LVM-maintenance mode, refer to “LVM-Maintenance Mode HP-UX Booting (BCH Menu)” on page 136.
- On HP Integrity servers, to boot HP-UX in LVM-maintenance mode, refer to “LVM-Maintenance Mode HP-UX Booting (EFI Shell)” on page 137.

LVM-Maintenance Mode HP-UX Booting (BCH Menu)

From the BCH Menu, you can boot HP-UX in LVM-maintenance mode by issuing the BOOT command, stopping at the ISL interface, and issuing hpux loader options. The BCH Menu is available only on HP 9000 servers.

- Step 1.** Access the BCH Main Menu for the nPartition on which you want to boot HP-UX in LVM-maintenance mode.

Log in to the management processor, and enter `CO` to access the Console list. Select the nPartition console. When accessing the console, confirm that you are at the BCH Main Menu (the `Main Menu: Enter command or menu>` prompt). If you are at a BCH menu other than the Main Menu, then enter `MA` to return to the BCH Main Menu.

- Step 2.** Boot the desired device by using the `BOOT` command at the BCH interface, and specify that the nPartition stop at the ISL prompt prior to booting (reply `y` to the “stop at the ISL prompt” question).

- Step 3.** From the ISL prompt, issue the appropriate Secondary System Loader (`hpux`) command to boot the HP-UX kernel in the desired mode.

To boot HP-UX in LVM-maintenance mode:

```
ISL> hpux -lm boot /stand/vmunix
```

- Step 4.** Exit the console and management processor interfaces if you are finished using them.

To exit the BCH environment, press **^B (Control+B)**; this exits the nPartition console and returns to the management processor Main Menu. To exit the management processor, enter `X` at the Main Menu.

LVM-Maintenance Mode HP-UX Booting (EFI Shell)

From the EFI Shell environment, boot in LVM-maintenance mode by stopping the boot process at the `HPUX.EFI` interface (the HP-UX Boot Loader prompt, `HPUX>`) by entering the `boot -lm vmunix` command. The EFI Shell is available only on HP Integrity servers.

Refer to “ACPI Configuration for HP-UX Must Be default” on page 130 for required configuration details.

- Step 1.** Access the EFI Shell environment for the nPartition on which you want to boot HP-UX in LVM-maintenance mode.

Log in to the management processor, and enter `CO` to access the Console list. Select the nPartition console.

When accessing the console, confirm that you are at the EFI Boot Manager menu (the main EFI menu). If you are at another EFI menu, select the Exit option from the submenus until you return to the screen with the `EFI Boot Manager` heading.

From the EFI Boot Manager menu, select the EFI Shell menu option to access the EFI Shell environment.

- Step 2.** Access the EFI System Partition for the device from which you want to boot HP-UX (`fsX`: where `X` is the file system number).

- Step 3.** When accessing the EFI System Partition for the desired boot device, issue the `HPUX` command to initiate the `\EFI\HPUX\HPUX.EFI` loader on the device you are accessing.

- Step 4.** Type any key within the 10 seconds given for interrupting the HP-UX boot process. This stops the boot process at the `HPUX.EFI` interface (the HP-UX Boot Loader prompt, `HPUX>`).

- Step 5.** At the `HPUX.EFI` interface, enter the `boot -lm vmunix` command to boot HP-UX (the `/stand/vmunix` kernel) in LVM-maintenance (`-lm`) mode.

- Step 6.** Exit the console and management processor interfaces if you are finished using them.

To exit the EFI environment, press **^B (Control+B)**; this exits the nPartition console and returns to the management processor Main Menu. To exit the management processor, enter **x** at the Main Menu.

Shutting Down HP-UX

When HP-UX is running on an nPartition, you can shut down HP-UX using the `shutdown` command.

On nPartitions you have the following options when shutting down HP-UX:

- To shut down HP-UX and reboot an nPartition: `shutdown -r`
On cell-based HP Integrity servers, the `shutdown -r` command is equivalent to the `shutdown -R` command.
- To shut down HP-UX and halt an nPartition: `shutdown -h`
On cell-based HP Integrity servers, the `shutdown -h` command is equivalent to the `shutdown -R -H` command.
- To perform a reboot for reconfiguration of an nPartition: `shutdown -R`
- To hold an nPartition at a shutdown for reconfiguration state: `shutdown -R -H`

For details, refer to the *shutdown* (1M) manpage.

NOTE On HP rx7620, rx7640, rx8620, and rx8640 servers, you can configure the nPartition behavior when an OS is shut down and halted (`shutdown -h` or `shutdown -R -H`). The two options are to have hardware power off when the OS is halted, or to have the nPartition be made inactive (all cells are in a boot-is-blocked state).

The normal behavior for HP-UX shut down and halt is for the nPartition to be made inactive.

For details, refer to “ACPI Softpowerdown Configuration—OS Shutdown Behavior” on page 125.

Shutting Down HP-UX

From the HP-UX command line, issue the `shutdown` command to shut down the HP-UX OS.

Step 1. Log in to HP-UX running on the nPartition that you want to shut down.

Log in to the management processor for the server and use the Console menu to access the system console. Accessing the console through the MP enables you to maintain console access to the system after HP-UX has shut down.

Step 2. Issue the `shutdown` command with the appropriate command-line options.

The command-line options you specify dictate the way in which HP-UX is shut down, whether the nPartition is rebooted, and whether any nPartition configuration changes take place (for example, adding or removing cells).

Use the following list to choose an HP-UX shutdown option for your nPartition:

- Shut down HP-UX and halt the nPartition.

On cell-based HP Integrity servers, the `shutdown -h` command puts an nPartition into the shutdown for reconfiguration state; for details, refer to the discussion of `shutdown -R -H` in this list.

- Shut down HP-UX and reboot the nPartition.

Issue the `shutdown -r` command to shut down and reboot the nPartition.

On cell-based HP Integrity servers, the `shutdown -r` command is equivalent to the `shutdown -R` command.

- Perform a reboot for reconfiguration of the nPartition.

Issue the HP-UX `shutdown -R` command to perform a reboot for reconfiguration.

This shuts down HP-UX, reconfigures the nPartition if needed, and reboots the nPartition.

- Reboot the nPartition and put it into the shutdown for reconfiguration state.

Use the HP-UX `shutdown -R -H` command to hold the nPartition in the shutdown for reconfiguration state.

This leaves the nPartition and all its cells in an inactive state (the nPartition can be reconfigured remotely), unless the normal behavior has been modified. For details, refer to “ACPI Softpowerdown Configuration—OS Shutdown Behavior” on page 125.

To reboot the nPartition, you must do so manually by using the `BO` command at the management processor Command Menu.

If HP-UX is halted on the nPartition, thus not allowing you to use the `shutdown` command, you can reboot or reset the nPartition by issuing commands from the management processor Command Menu.

Booting and Shutting Down HP OpenVMS I64

This section presents procedures for booting and shutting down HP OpenVMS I64 on cell-based HP Integrity servers and procedures for adding HP OpenVMS to the boot options list.

- To determine whether the cell local memory (CLM) configuration is appropriate for HP OpenVMS, refer to “HP OpenVMS I64 Support for Cell Local Memory” on page 140.
- To add an HP OpenVMS entry to the boot options list, refer to “Adding HP OpenVMS to the Boot Options List” on page 140.
- To boot HP OpenVMS on a cell-based HP Integrity server, refer to “Booting HP OpenVMS” on page 142.
- To shut down HP OpenVMS, refer to “Shutting Down HP OpenVMS” on page 143.

HP OpenVMS I64 Support for Cell Local Memory

On servers based on the HP sx2000 chipset, each cell has a cell local memory (CLM) parameter, which determines how firmware interleaves memory residing on the cell.

IMPORTANT HP OpenVMS I64 does not support using CLM. Before booting OpenVMS on an nPartition, you must ensure that the CLM parameter for each cell in the nPartition is set to zero (0). Although you might be able to boot OpenVMS on an nPartition with CLM configured, any memory configured as cell local is unusable, and such a configuration is untested and unsupported.

To check CLM configuration details from an OS, use Partition Manager or the `parstatus` command. For example, the `parstatus -v -c#` command and `parstatus -v -p#` command report the CLM amount requested and CLM amount allocated for the specified cell (`-c#`, where `#` is the cell number) or the specified nPartition (`-p#`, where `#` is the nPartition number). For details, refer to the *HP System Partitions Guide* or the Partition Manager Web site (<http://docs.hp.com/en/PARMGR2/>).

To display CLM configuration details from the EFI Shell on a cell-based HP Integrity server, use the `info mem` command. If the amount of noninterleaved memory reported is less than 512 MB, then no CLM is configured for any cells in the nPartition (and the indicated amount of noninterleaved memory is used by system firmware). If the `info mem` command reports more than 512 MB of noninterleaved memory, then use Partition Manager or the `parstatus` command to confirm the CLM configuration details.

To set the CLM configuration, use Partition Manager or the `parmodify` command. For details, refer to the *HP System Partitions Guide* or the Partition Manager Web site (<http://docs.hp.com/en/PARMGR2/>).

Adding HP OpenVMS to the Boot Options List

On HP Integrity servers, you can use the following procedures to manage boot options list entries for HP OpenVMS.

You can add the `\efi\vms\vms_loader.efi` loader to the boot options list from the EFI Shell or EFI Boot Configuration menu (or in some versions of EFI, the Boot Option Maintenance Menu).

See “Boot Options List” on page 123 for additional information about saving, restoring, and creating boot options.

NOTE OpenVMS I64 installation and upgrade procedures assist you in setting up and validating a boot option for your system disk. HP recommends that you allow the procedure to do this.

To configure booting on Fibre Channel devices, you must use the OpenVMS I64 Boot Manager utility (`BOOT_OPTIONS.COM`). For more information on this utility and other restrictions, refer to the *HP OpenVMS for Integrity Servers Upgrade and Installation Manual*.

Adding an HP OpenVMS Boot Option

This procedure adds an HP OpenVMS item to the boot options list from the EFI Shell.

To add an HP OpenVMS boot option when logged in to OpenVMS, use the `@SYS$MANAGER:BOOT_OPTIONS.COM` command.

Step 1. Access the EFI Shell environment.

Log in to the management processor, and enter `CO` to access the system console.

When accessing the console, confirm that you are at the EFI Boot Manager menu (the main EFI menu). If you are at another EFI menu, select the Exit option from the submenus until you return to the screen with the EFI Boot Manager heading.

From the EFI Boot Manager menu, select the EFI Shell menu option to access the EFI Shell environment.

Step 2. Access the EFI System Partition for the device from which you want to boot HP OpenVMS (`fsX:`, where *X* is the file system number).

For example, enter `fs2:` to access the EFI System Partition for the bootable file system number 2. The EFI Shell prompt changes to reflect the file system currently accessed.

The full path for the HP OpenVMS loader is `\efi\vms\vms_loader.efi`, and it should be on the device you are accessing.

Step 3. At the EFI Shell environment, use the `bcfg` command to manage the boot options list.

You can also accomplish this step by using the `\efi\vms\vms_bcfg.efi` and `\efi\vms\vms_show.efi` utilities, which are available on the EFI System Partition for HP OpenVMS. Both `vms_bcfg` and `vms_show` are unique utilities for OpenVMS I64. The `vms_bcfg` utility differs from the `bcfg` EFI command in that `vms_bcfg` enables you to specify boot devices using device names consistent with OpenVMS naming conventions.

The `bcfg` command includes the following options for managing the boot options list:

- `bcfg boot dump` — Display all items in the boot options list for the system.
- `bcfg boot rm #` — Remove the item number specified by `#` from the boot options list.
- `bcfg boot mv #a #b` — Move the item number specified by `#a` to the position specified by `#b` in the boot options list.
- `bcfg boot add # file.efi "Description"` — Add a new boot option to the position in the boot options list specified by `#`. The new boot option references `file.efi` and is listed with the title specified by `Description`.

For example, `bcfg boot add 1 \efi\vms\vms_loader.efi "HP OpenVMS"` adds an HP OpenVMS item as the first entry in the boot options list.

Refer to the `help bcfg` command for details.

Step 4. Exit the console and management processor interfaces if you are finished using them.

To exit the EFI environment, press **^B (Control+B)**; this exits the nPartition console and returns to the management processor Main Menu. To exit the management processor, enter **x** at the Main Menu.

Booting HP OpenVMS

To boot HP OpenVMS I64 on a cell-based HP Integrity server use either of the following procedures.

- “Booting HP OpenVMS (EFI Boot Manager)” on page 142
- “Booting HP OpenVMS (EFI Shell)” on page 143

CAUTION ACPI Configuration for HP OpenVMS I64 Must Be default

On cell-based HP Integrity servers, to boot the HP OpenVMS OS, an nPartition ACPI configuration value must be set to default.

At the EFI Shell interface, enter the `acpiconfig` command with no arguments to list the current ACPI configuration. If the `acpiconfig` value is not set to default, then OpenVMS cannot boot. In this situation, you must reconfigure `acpiconfig`; otherwise, booting will fail and report the `INCONSTATE` code when OpenVMS is launched.

To set the ACPI configuration for HP OpenVMS I64:

1. At the EFI Shell interface enter the `acpiconfig default` command.
 2. Enter the `reset` command for the nPartition to reboot with the proper (default) configuration for OpenVMS.
-

Booting HP OpenVMS (EFI Boot Manager)

From the EFI Boot Manager menu, select an item from the boot options list to boot HP OpenVMS using the selected boot option.

- Step 1.** Access the EFI Boot Manager menu for the system on which you want to boot HP OpenVMS.

Log in to the management processor, and enter `CO` to select the system console.

When accessing the console, confirm that you are at the EFI Boot Manager menu (the main EFI menu). If you are at another EFI menu, select the `Exit` option from the submenus until you return to the screen with the `EFI Boot Manager` heading.

- Step 2.** At the EFI Boot Manager menu, select an item from the boot options list.

Each item in the boot options list references a specific boot device and provides a specific set of boot options or arguments to use when booting the device.

- Step 3.** Press **Enter** to initiate booting using the selected boot option.

- Step 4.** Exit the console and management processor interfaces when you have finished using them.

To exit the EFI environment press **^B (Control+B)**; this exits the system console and returns to the management processor Main Menu. To exit the management processor, enter **x** at the Main Menu.

Booting HP OpenVMS (EFI Shell)

From the EFI Shell environment, to boot HP OpenVMS on a device first access the EFI System Partition for the root device (for example `fs0:`), and enter `\efi\vms\vms_loader` to initiate the OpenVMS loader.

- Step 1.** Access the EFI Shell environment for the system on which you want to boot HP OpenVMS.

Log in to the management processor, and enter `CO` to select the system console.

When accessing the console, confirm that you are at the EFI Boot Manager menu (the main EFI menu). If you are at another EFI menu, select the Exit option from the submenus until you return to the screen with the EFI Boot Manager heading.

From the EFI Boot Manager menu, select the EFI Shell menu option to access the EFI Shell environment.

- Step 2.** At the EFI Shell environment, issue the `map` command to list all currently mapped bootable devices.

The bootable file systems of interest typically are listed as `fs0:`, `fs1:`, and so on.

- Step 3.** Access the EFI System Partition for the device from which you want to boot HP OpenVMS (`fsX:`, where *X* is the file system number).

For example, enter `fs2:` to access the EFI System Partition for the bootable file system number 2. The EFI Shell prompt changes to reflect the file system currently accessed.

Also, the file system number might change each time it is mapped (for example, when the system boots, or when the `map -r` command is issued).

- Step 4.** When accessing the EFI System Partition for the desired boot device, issue the `\efi\vms\vms_loader` command to initiate the `vms_loader.efi` loader on the device you are accessing.

```
fs5:> \efi\vms\vms_loader.efi
```

```
HP OpenVMS Industry Standard 64 Operating System, Version V8.2-1  
Copyright 1976-2005 Hewlett-Packard Development Company, L.P.
```

```
%PKA0, Copyright (c) 1998 LSI Logic PKW V3.2.20 ROM 4.19  
%PKA0, SCSI Chip is SYM53C1010/66, Operating mode is LVD Ultra3 SCSI  
%SMP-I-CPUTRN, CPU #01 has joined the active set.  
%SMP-I-CPUTRN, CPU #02 has joined the active set.  
...
```

- Step 5.** Exit the console and management processor interfaces when you have finished using them.

To exit the EFI environment press **^B (Control+B)**; this exits the system console and returns to the management processor Main Menu. To exit the management processor, enter `X` at the Main Menu.

Shutting Down HP OpenVMS

This section describes how to shut down the HP OpenVMS OS on cell-based HP Integrity servers.

Shutting Down HP OpenVMS

From the HP OpenVMS command line, issue the `@SYS$SYSTEM:SHUTDOWN` command to shut down the OpenVMS OS.

- Step 1.** Log in to HP OpenVMS running on the system that you want to shut down.

Log in to the management processor (MP) for the server and use the Console menu to access the system console. Accessing the console through the MP enables you to maintain console access to the system after HP OpenVMS has shut down.

- Step 2.** At the OpenVMS command line (DCL) issue the @SYS\$SYSTEM:SHUTDOWN command and specify the shutdown options in response to the prompts given.

```
>@SYS$SYSTEM:SHUTDOWN

          SHUTDOWN -- Perform an Orderly System Shutdown
                   on node RSNVMS

How many minutes until final shutdown [0]:
Reason for shutdown [Standalone]:
Do you want to spin down the disk volumes [NO]?
Do you want to invoke the site-specific shutdown procedure [YES]?
Should an automatic system reboot be performed [NO]? yes
When will the system be rebooted [shortly via automatic reboot]:
Shutdown options (enter as a comma-separated list):
  REBOOT_CHECK      Check existence of basic system files
  SAVE_FEEDBACK    Save AUTOGEN feedback information from this boot
  DISABLE_AUTOSTART Disable autostart queues
  POWER_OFF        Request console to power-off the system

Shutdown options [NONE]:

%SHUTDOWN-I-OPERATOR, this terminal is now an operator's console
...
```

NOTE HP OpenVMS I64 currently does not support the POWER_OFF shutdown option.

The SYS\$SYSTEM:SHUTDOWN.COM command prompts establish the shutdown behavior, including the shutdown time and whether the system is rebooted after it is shut down.

- To perform a reboot for reconfig from OpenVMS I64 running on an nPartition, issue @SYS\$SYSTEM:SHUTDOWN.COM from OpenVMS, and then enter Yes at the “Should an automatic system reboot be performed” prompt.
- To perform a shutdown for reconfig of an nPartition running OpenVMS I64:
 1. Issue @SYS\$SYSTEM:SHUTDOWN.COM from OpenVMS and enter No at the “Should an automatic system reboot be performed” prompt.
 2. Access the management processor and, from the management processor Command Menu, issue the RR command and specify the nPartition. The nPartition you specify will be put in the shutdown for reconfig state.

Booting and Shutting Down Microsoft Windows

This section presents procedures for booting and shutting down the Microsoft Windows OS on cell-based HP Integrity servers and a procedure for adding Windows to the boot options list.

- To determine whether the cell local memory (CLM) configuration is appropriate for Windows, refer to “Microsoft Windows Support for Cell Local Memory” on page 145.
- To add a Windows entry to the boot options list, refer to “Adding Microsoft Windows to the Boot Options List” on page 145.
- To boot Windows, refer to “Booting Microsoft Windows” on page 147.
- To shut down Windows, refer to “Shutting Down Microsoft Windows” on page 148.

Microsoft Windows Support for Cell Local Memory

On servers based on the HP sx2000 chipset, each cell has a cell local memory (CLM) parameter, which determines how firmware interleaves memory residing on the cell.

IMPORTANT Microsoft Windows supports using CLM on cell-based HP Integrity servers. For best performance in an nPartition running Windows, HP recommends that you configure the CLM parameter to 100 percent for each cell in the nPartition.

To check CLM configuration details from an OS, use Partition Manager or the `parstatus` command. For example, the `parstatus -v -c#` command and `parstatus -v -p#` command report the CLM amount requested and CLM amount allocated for the specified cell (`-c#`, where `#` is the cell number) or the specified nPartition (`-p#`, where `#` is the nPartition number). For details, refer to the *HP System Partitions Guide* or the Partition Manager Web site (<http://docs.hp.com/en/PARMGR2/>).

To display CLM configuration details from the EFI Shell on a cell-based HP Integrity server, use the `info mem` command. If the amount of noninterleaved memory reported is less than 512 MB, then no CLM is configured for any cells in the nPartition (and the indicated amount of noninterleaved memory is used by system firmware). If the `info mem` command reports more than 512 MB of noninterleaved memory, then use Partition Manager or the `parstatus` command to confirm the CLM configuration details.

To set the CLM configuration, use Partition Manager or the `parmodify` command. For details, refer to the *HP System Partitions Guide* or the Partition Manager Web site (<http://docs.hp.com/en/PARMGR2/>).

Adding Microsoft Windows to the Boot Options List

To add a Microsoft Windows entry to the system boot options list, you must do so from EFI. Use the `\MSUtil\nvrboot.efi` utility to import boot options from the `EFI\Microsoft\WINNT50\Boot00...` file on the device from which Windows is loaded.

See “Boot Options List” on page 123 for additional information about saving, restoring, and creating boot options.

NOTE On HP Integrity servers, the OS installer automatically adds an entry to the boot options list.

Adding a Microsoft Windows Boot Option

This procedure adds the Microsoft Windows item to the boot options list.

Step 1. Access the EFI Shell environment.

Log in to the management processor, and enter CO to access the system console.

When accessing the console, confirm that you are at the EFI Boot Manager menu (the main EFI menu). If you are at another EFI menu, select the Exit option from the submenus until you return to the screen with the EFI Boot Manager heading.

From the EFI Boot Manager menu, select the EFI Shell menu option to access the EFI Shell environment.

Step 2. Access the EFI System Partition for the device from which you want to boot Microsoft Windows (fsX: where X is the file system number).

For example, enter fs2: to access the EFI System Partition for the bootable file system number 2. The EFI Shell prompt changes to reflect the file system currently accessed.

The full path for the Microsoft Windows loader is \efi\microsoft\winnt50\ia64ldr.efi, and it should be on the device you are accessing. (However, you must initiate this loader only from the EFI Boot Menu and not from the EFI Shell.)

Step 3. List the contents of the \EFI\Microsoft\WINNT50 directory to identify the name of the Windows boot option file (Boot00nn) that you want to import into the system boot options list.

```
fs0:\> ls EFI\Microsoft\WINNT50
Directory of: fs0:\EFI\Microsoft\WINNT50

    09/18/03  11:58a <DIR>          1,024  .
    09/18/03  11:58a <DIR>          1,024  ..
    12/18/03  08:16a                   354   Boot0001
           1 File(s)             354 bytes
           2 Dir(s)
```

```
fs0:\>
```

Step 4. At the EFI Shell environment, issue the \MSUtil\nvrboot.efi command to launch the Microsoft Windows boot options utility.

```
fs0:\> msutil\nvrboot

NVRBOOT: OS Boot Options Maintenance Tool [Version 5.2.3683]

    1. SUSE SLES 9
    2. HP-UX Primary Boot: 0/0/1/0/0.2.0
    * 3. Windows Server 2003, Datacenter
    4. EFI Shell [Built-in]

    * = Windows OS boot option

    (D)isplay (M)odify (C)opy E(x)port (I)mport (E)rase (P)ush (H)elp (Q)uit

Select>
```

Step 5. Use the Import command to import the Windows boot options file.

```
Select> i
Enter IMPORT file path: \EFI\Microsoft\WINNT50\Boot0001
Imported Boot Options from file: \EFI\Microsoft\WINNT50\Boot0001

Press enter to continue
```

Step 6. Press **Q** to quit the NVRBOOT utility, and exit the console and management processor interfaces if you are finished using them.

To exit the EFI environment press **^B (Control+B)**; this exits the system console and returns to the management processor Main Menu. To exit the management processor, enter **x** at the Main Menu.

Booting Microsoft Windows

You can boot the Windows Server 2003 OS on an HP Integrity server by using the EFI Boot Manager to choose the appropriate Windows item from the boot options list.

Refer to “Shutting Down Microsoft Windows” on page 148 for details on shutting down the Windows OS.

CAUTION ACPI Configuration for Windows Must Be windows

On cell-based HP Integrity servers, to boot the Windows OS, an nPartition ACPI configuration value must be set to windows.

At the EFI Shell, enter the `acpiconfig` command with no arguments to list the current ACPI configuration. If the `acpiconfig` value is not set to windows, then Windows cannot boot. In this situation, you must reconfigure `acpiconfig`; otherwise, booting will be interrupted with a panic when Windows is launched.

To set the ACPI configuration for Windows: At the EFI Shell enter the `acpiconfig windows` command, and then enter the `reset` command for the nPartition to reboot with the proper (windows) configuration for Windows.

NOTE Microsoft Windows Booting on HP Integrity Servers

The recommended method for booting Windows is to use the EFI Boot Manager menu to choose a Windows entry from the boot options list. Using the `ia64ldr.efi` Windows loader from the EFI Shell is not recommended.

Windows Booting

From the EFI Boot Manager menu, select an item from the boot options list to boot Windows using that boot option. The EFI Boot Manager is available only on HP Integrity servers.

Refer to “ACPI Configuration for Windows Must Be windows” on page 147 for required configuration details.

Step 1. Access the EFI Boot Manager menu for the system on which you want to boot Windows.

Log in to the management processor, and enter `CO` to access the Console list. Select the nPartition console.

When accessing the console, confirm that you are at the EFI Boot Manager menu (the main EFI menu). If you are at another EFI menu, select the Exit option from the submenus until you return to the screen with the EFI Boot Manager heading.

Step 2. At the EFI Boot Manager menu, select an item from the boot options list.

Each item in the boot options list references a specific boot device and provides a specific set of boot options or arguments to be used when booting the device.

Step 3. Press **Enter** to initiate booting using the chosen boot option.

Step 4. When Windows begins loading, wait for the Special Administration Console (SAC) to become available.

The SAC interface provides a text-based administration tool that is available from the nPartition console. For details, refer to the SAC online help (type **?** at the SAC> prompt).

```
Loading.: Windows Server 2003, Datacenter
Starting: Windows Server 2003, Datacenter
```

```

                Starting Windows...
*****
Computer is booting, SAC started and initialized.

Use the "ch -?" command for information about using channels.
Use the "?" command for general help.

SAC>
```

Step 5. Exit the console and management processor interfaces if you are finished using them.

To exit the console environment, press **^B (Control+B)**; this exits the console and returns to the management processor Main menu. To exit the management processor, enter **X** at the Main menu.

Shutting Down Microsoft Windows

You can shut down the Windows OS on HP Integrity servers using the **Start** menu or the `shutdown` command.

CAUTION Do not shut down Windows using Special Administration Console (SAC) `restart` or `shutdown` commands under normal circumstances.

Issuing `restart` or `shutdown` at the SAC> prompt causes the system to restart or shut down immediately and can result in the loss of data.

Instead, use the Windows **Start** menu or the `shutdown` command to shut down without loss of data.

To shut down Windows use either of the following methods.

- Select **Shut Down** from the **Start** menu, and select either **Restart** or **Shut down** from the drop-down menu. Selecting the **Restart** menu item shuts down and restarts the system. Selecting the **Shut down** menu item shuts down the system. You can use this method when using the Windows graphical interface.
- Issue the `shutdown` command from the Windows command line. Refer to the procedure “Windows Shutdown from the Command Line” on page 149 for details. You can issue this command from a command prompt through the Special Administration Console (SAC) or from any other command line.

The Windows `shutdown` command includes the following options:

```
/s          Shut down the system. This is the equivalent of Start—>Shut Down, Shut down.
/r          Shut down and restart the system. This is the equivalent of Start—>Shut Down, Restart.
```

- `/a` Abort a system shutdown.
- `/t xxx` Set the timeout period before shutdown to `xxx` seconds. The timeout period can range from 0–600, with a default of 30.

Refer to the `help shutdown` Windows command for details.

NOTE On HP rx7620, rx7640, rx8620, and rx8640 servers, performing a shutdown using `shutdown /s` (or the equivalent **Start—>Shut Down, Shut down**) powers off the server cabinet or powers off the cells and I/O chassis assigned to the nPartition. You can customize this behavior. For details, refer to “ACPI Softpowerdown Configuration—OS Shutdown Behavior” on page 125.

On HP Integrity Superdome servers, the Windows `shutdown /s` command shuts down the system and keeps all cells at the boot-is-blocked (BIB) inactive state.

Windows Shutdown from the Command Line

From the Windows command line, issue the `shutdown` command to shut down the OS.

Step 1. Log in to Windows running on the system that you want to shut down.

For example, access the system console and use the Windows SAC interface to start a command prompt, from which you can issue Windows commands to shut down the the system.

Step 2. Check whether any users are logged in.

Use the `query user` or `query session` command.

Step 3. Issue the `shutdown` command and the appropriate options to shut down the Windows Server 2003 on the system.

You have the following options when shutting down Windows:

- To shut down Windows and reboot:

shutdown /r

Alternatively, you can select the **Start —> Shut Down** action and select **Restart** from the drop-down menu.

- To shut down Windows and not reboot (either power down server hardware or put an nPartition into a shutdown for reconfiguration state):

shutdown /s

Alternatively, you can select the **Start —> Shut Down** action and select **Shut down** from the drop-down menu.

- To abort a shutdown (stop a shutdown that has been initiated): **shutdown /a**

For example:

```
shutdown /r /t 60 /c "Shut down in one minute."
```

This command initiates a Windows system shutdown-and-reboot after a timeout period of 60 seconds. The `/c` option specifies a message that is broadcast to any other users of the system.

Booting and Shutting Down Linux

This section presents procedures for booting and shutting down the Linux OS on cell-based HP Integrity servers and a procedure for adding Linux to the boot options list.

- To determine whether the cell local memory (CLM) configuration is appropriate for Red Hat Enterprise Linux or SuSE Linux Enterprise Server, refer to “Linux Support for Cell Local Memory” on page 150.
- To add a Linux entry to the nPartition boot options list, refer to “Adding Linux to the Boot Options List” on page 150.
- To boot Red Hat Enterprise Linux, refer to “Booting Red Hat Enterprise Linux” on page 152.
- To boot SuSE Linux Enterprise Server, refer to “Booting SuSE Linux Enterprise Server” on page 153.
- To shut down Linux, refer to “Shutting Down Linux” on page 154.

Linux Support for Cell Local Memory

On servers based on the HP sx2000 chipset, each cell has a cell local memory (CLM) parameter, which determines how firmware interleaves memory residing on the cell.

IMPORTANT Red Hat Enterprise Linux does not support using CLM. Before booting Red Hat Enterprise Linux on an nPartition, you must ensure that the CLM parameter for each cell in the nPartition is set to zero (0). Although you might be able to boot Red Hat Enterprise Linux on an nPartition with CLM configured, any memory configured as cell local is unusable, and such a configuration is untested and unsupported.

SuSE Linux Enterprise Server supports using CLM. The optimal CLM settings for SuSE Linux Enterprise Server depend on the applications and workload the OS is running.

To check CLM configuration details from an OS, use Partition Manager or the `parstatus` command. For example, the `parstatus -v -c#` command and `parstatus -v -p#` command report the CLM amount requested and CLM amount allocated for the specified cell (`-c#`, where `#` is the cell number) or the specified nPartition (`-p#`, where `#` is the nPartition number). For details, refer to the *HP System Partitions Guide* or the Partition Manager Web site (<http://docs.hp.com/en/PARMGR2/>).

To display CLM configuration details from the EFI Shell on a cell-based HP Integrity server, use the `info mem` command. If the amount of noninterleaved memory reported is less than 512 MB, then no CLM is configured for any cells in the nPartition (and the indicated amount of noninterleaved memory is used by system firmware). If the `info mem` command reports more than 512 MB of noninterleaved memory, then use Partition Manager or the `parstatus` command to confirm the CLM configuration details.

To set the CLM configuration, use Partition Manager or the `parmodify` command. For details, refer to the *HP System Partitions Guide* or the Partition Manager Web site (<http://docs.hp.com/en/PARMGR2/>).

Adding Linux to the Boot Options List

This section describes how to add a Linux entry to the system boot options list. The processes for adding both Red Hat Enterprise Linux and SuSE Linux Enterprise Servers are given here.

You can add the `\EFI\redhat\elilo.efi` loader or the `\efi\SuSE\elilo.efi` loader to the boot options list from the EFI Shell or EFI Boot Configuration menu (or in some versions of EFI, the Boot Option Maintenance Menu).

See “Boot Options List” on page 123 for additional information about saving, restoring, and creating boot options.

NOTE On HP Integrity servers, the OS installer automatically adds an entry to the boot options list.

Adding a Linux Boot Option

This procedure adds a Linux item to the boot options list.

Step 1. Access the EFI Shell environment.

Log in to the management processor, and enter `CO` to access the system console.

When accessing the console, confirm that you are at the EFI Boot Manager menu (the main EFI menu). If you are at another EFI menu, select the Exit option from the submenus until you return to the screen with the EFI Boot Manager heading.

From the EFI Boot Manager menu, select the EFI Shell menu option to access the EFI Shell environment.

Step 2. Access the EFI System Partition for the device from which you want to boot Linux (`fsX:`, where *X* is the file system number).

For example, enter `fs2:` to access the EFI System Partition for the bootable file system number 2. The EFI Shell prompt changes to reflect the file system currently accessed.

The full path for the Red Hat Enterprise Linux loader is `\EFI\redhat\elilo.efi`, and it should be on the device you are accessing.

The full path for the SuSE Linux Enterprise Server loader is `\efi\SuSE\elilo.efi`, and it should be on the device you are accessing.

Step 3. At the EFI Shell environment, use the `bcfg` command to manage the boot options list.

The `bcfg` command includes the following options for managing the boot options list:

- `bcfg boot dump` — Display all items in the boot options list for the system.
- `bcfg boot rm #` — Remove the item number specified by `#` from the boot options list.
- `bcfg boot mv #a #b` — Move the item number specified by `#a` to the position specified by `#b` in the boot options list.
- `bcfg boot add # file.efi "Description"` — Add a new boot option to the position in the boot options list specified by `#`. The new boot option references `file.efi` and is listed with the title specified by `Description`.

For example, `bcfg boot add 1 \EFI\redhat\elilo.efi "Red Hat Enterprise Linux"` adds a Red Hat Enterprise Linux item as the first entry in the boot options list.

Likewise, `bcfg boot add 1 \efi\SuSE\elilo.efi "SLES 9"` adds a SuSE Linux item as the first entry in the boot options list.

Refer to the help `bcfg` command for details.

Step 4. Exit the console and management processor interfaces if you are finished using them.

To exit the EFI environment press **^B (Control+B)**; this exits the system console and returns to the management processor Main Menu. To exit the management processor, enter **x** at the Main Menu.

Booting Red Hat Enterprise Linux

You can boot the Red Hat Enterprise Linux OS on HP Integrity servers using either of the methods described in this section.

Refer to “Shutting Down Linux” on page 154 for details on shutting down the Red Hat Enterprise Linux OS.

CAUTION ACPI Configuration for Red Hat Enterprise Linux Must Be default

On cell-based HP Integrity servers, to boot the Red Hat Enterprise Linux OS, an nPartition ACPI configuration must be value set to default.

At the EFI Shell, enter the `acpiconfig` command with no arguments to list the current ACPI configuration. If the `acpiconfig` value is not set to default, then Red Hat Enterprise Linux could panic. In this situation, you must reconfigure `acpiconfig` to eliminate any bus address conflicts and ensure all I/O slots have unique addresses.

To set the ACPI configuration for Red Hat Enterprise Linux:

- At the EFI Shell enter the `acpiconfig default` command.
- Enter the `reset` command for the nPartition to reboot with the proper (default) configuration for Red Hat Enterprise Linux.

Use either of the following methods to boot Red Hat Enterprise Linux:

- Choose a Red Hat Enterprise Linux entry from the EFI Boot Manager menu.

To load the Red Hat Enterprise Linux OS at the EFI Boot Manager menu, choose its entry from the list of boot options.

Choosing a Linux entry from the boot options list boots the OS using `ELILO.EFI` loader and the `elilo.conf` file.

- Initiate the `ELILO.EFI` Linux loader from the EFI Shell.

Refer to the procedure “Booting Red Hat Enterprise Linux (EFI Shell)” on page 152 for details.

After choosing the file system for the boot device (for example, `fs0:`), you can initiate the Linux loader from the EFI Shell prompt by entering the full path for the `ELILO.EFI` loader.

On a Red Hat Enterprise Linux boot device EFI System Partition, the full paths to the loader and configuration files are:

```
\EFI\redhat\elilo.efi
\EFI\redhat\elilo.conf
```

By default the `ELILO.EFI` loader boots Linux using the kernel image and parameters specified by the default entry in the `elilo.conf` file on the EFI System Partition for the boot device.

To interact with the `ELILO.EFI` loader, interrupt the boot process (for example, type a space) at the `ELILO` boot prompt. To exit the `ELILO.EFI` loader, use the `exit` command.

Booting Red Hat Enterprise Linux (EFI Shell)

Use this procedure to boot Red Hat Enterprise Linux from the EFI Shell.

Refer to “ACPI Configuration for Red Hat Enterprise Linux Must Be default” on page 152 for required configuration details.

Step 1. Access the EFI Shell.

From the system console, select the EFI Shell entry from the EFI Boot Manager menu to access the shell.

Step 2. Access the EFI System Partition for the Red Hat Enterprise Linux boot device.

Use the `map EFI Shell` command to list the file systems (`fs0`, `fs1`, and so on) that are known and have been mapped.

To select a file system to use, enter its mapped name followed by a colon (:). For example, to operate with the boot device that is mapped as `fs3`, enter `fs3:` at the EFI Shell prompt.

Step 3. Enter `ELILO` at the EFI Shell command prompt to launch the `ELILO.EFI` loader.

If needed, you can specify the loader’s full path by entering `\EFI\redhat\elilo` at the EFI Shell command prompt.

Step 4. Allow the `ELILO.EFI` loader to proceed with booting the Red Hat Enterprise Linux kernel.

By default, the `ELILO.EFI` loader boots the kernel image and options specified by the default item in the `elilo.conf` file.

To interact with the `ELILO.EFI` loader, interrupt the boot process (for example, type a space) at the `ELILO` boot prompt. To exit the loader, use the `exit` command.

Booting SuSE Linux Enterprise Server

You can boot the SuSE Linux Enterprise Server 9 OS on HP Integrity servers using either of the methods described in this section.

Refer to “Shutting Down Linux” on page 154 for details on shutting down the SuSE Linux Enterprise Server OS.

CAUTION **ACPI Configuration for SuSE Linux Enterprise Server Must Be default**

On cell-based HP Integrity servers, to boot the SuSE Linux Enterprise Server OS, an `nPartition` ACPI configuration value must be set to `default`.

At the EFI Shell, enter the `acpiconfig` command with no arguments to list the current ACPI configuration. If the `acpiconfig` value is not set to `default`, then SuSE Linux Enterprise Server could panic.

To set the ACPI configuration for SuSE Linux Enterprise Server:

- At the EFI Shell enter the `acpiconfig default` command.
- Enter the `reset` command for the `nPartition` to reboot with the proper (default) configuration for SuSE Linux Enterprise Server.

Use either of the following methods to boot SuSE Linux Enterprise Server:

- Choose a SuSE Linux Enterprise Server entry from the EFI Boot Manager menu.

To load the SuSE Linux Enterprise Server OS at the EFI Boot Manager menu, choose its entry from the list of boot options.

Choosing a Linux entry from the boot options list boots the OS using `ELILO.EFI` loader and the `elilo.conf` file.

- Initiate the `ELILO.EFI` Linux loader from the EFI Shell.

Refer to the procedure “Booting SuSE Linux Enterprise Server (EFI Shell)” on page 154 for details.

After choosing the file system for the boot device (for example, `fs0:`), you can initiate the Linux loader from the EFI Shell prompt by entering the full path for the `ELILO.EFI` loader.

On a SuSE Linux Enterprise Server boot device EFI System Partition, the full paths to the loader and configuration files are:

```
\efi\SuSE\elilo.efi
\efi\SuSE\elilo.conf
```

By default the `ELILO.EFI` loader boots Linux using the kernel image and parameters specified by the default entry in the `elilo.conf` file on the EFI System Partition for the boot device.

To interact with the `ELILO.EFI` loader, interrupt the boot process (for example, type a space) at the `ELILO` boot prompt. To exit the `ELILO.EFI` loader, use the `exit` command.

Booting SuSE Linux Enterprise Server (EFI Shell)

Use this procedure to boot SuSE Linux Enterprise Server 9 from the EFI Shell.

Refer to “ACPI Configuration for SuSE Linux Enterprise Server Must Be default” on page 153 for required configuration details.

Step 1. Access the EFI Shell.

From the system console, select the EFI Shell entry from the EFI Boot Manager menu to access the shell.

Step 2. Access the EFI System Partition for the SuSE Linux Enterprise Server boot device.

Use the `map` EFI Shell command to list the file systems (`fs0`, `fs1`, and so on) that are known and have been mapped.

To select a file system to use, enter its mapped name followed by a colon (:). For example, to operate with the boot device that is mapped as `fs3`, enter `fs3:` at the EFI Shell prompt.

Step 3. Enter **ELILO** at the EFI Shell command prompt to launch the `ELILO.EFI` loader.

If needed, you can specify the loader’s full path by entering `\efi\SuSE\elilo` at the EFI Shell command prompt.

Step 4. Allow the `ELILO.EFI` loader to proceed with booting the SuSE Linux kernel.

By default, the `ELILO.EFI` loader boots the kernel image and options specified by the default item in the `elilo.conf` file.

To interact with the `ELILO.EFI` loader, interrupt the boot process (for example, type a space) at the `ELILO` boot prompt. To exit the loader, use the `exit` command.

Shutting Down Linux

Use the `shutdown` command to shut down Red Hat Enterprise Linux or SuSE Linux Enterprise Server.

The Red Hat Enterprise Linux and SuSE Linux Enterprise Server `shutdown` command includes the following options:

- `-h` Halt after shutdown.
On cell-based HP Integrity servers, this either powers down server hardware or puts the nPartition into a shutdown for reconfiguration state.
Use the `PE` command at the management processor Command Menu to manually power on or power off server hardware, as needed.
- `-r` Reboot after shutdown.
- `-c` Cancel an already running shutdown.
- `time` When to shut down (required). You can specify the `time` option in any of the following ways:
 - Absolute time in the format `hh:mm`, in which `hh` is the hour (one or two digits) and `mm` is the minute of the hour (two digits).
 - Number of minutes to wait in the format `+m`, in which `m` is the number of minutes.
 - `now` to immediately shut down; this is equivalent to using `+0` to wait zero minutes.

Refer to the `shutdown(8)` Linux manpage for details. Also refer to the Linux manpage for the `poweroff` command.

NOTE On HP rx7620, rx7640, rx8620, and rx8640 servers, you can configure the nPartition behavior when an OS is shut down and halted (`shutdown -h` or `poweroff`). The two options are to have hardware power off when the OS is halted or to have the nPartition be made inactive (all cells are in a boot-is-blocked state).

The normal behavior for Red Hat Enterprise Linux or SuSE Linux Enterprise Server shut down and halt is for the nPartition to be made inactive.

For details, refer to “ACPI Softpowerdown Configuration—OS Shutdown Behavior” on page 125.

Shutting Down Linux

From the command line for Red Hat Enterprise Linux or SuSE Linux Enterprise Server, issue the `shutdown` command to shut down the OS.

Step 1. Log in to Linux running on the system you want to shut down.

Log in to the management processor (MP) for the server and use the Console menu to access the system console. Accessing the console through the MP enables you to maintain console access to the system after Linux has shut down.

Step 2. Issue the `shutdown` command with the desired command-line options, and include the required `time` argument to specify when the operating shutdown is to occur.

For example, `shutdown -r +20` will shut down and reboot the system starting in 20 minutes.

5 Server Troubleshooting

This chapter contains tips and procedures for diagnosing and correcting problems with the server and its customer replaceable units (CRUs). Information about the various status LEDs on the server is also included.

Common Installation Problems

The following sections contain general procedures to help you locate installation problems.

CAUTION Do not operate the server with the top cover removed for an extended period of time. Overheating can damage chips, boards, and mass storage devices. However, you can safely remove the top cover while the server is running to remove and replace PCI hot-plug cards.

Most problems are the result of incorrect system and SCSI subsystem configurations.

Use the following checklist to troubleshoot an installation problem:

- a. Check all cable and power connections, including those in the rack, and so on.
- b. Ensure the server is configured properly.
- c. Verify all cables and boards are securely plugged into the appropriate connectors or slots.
- d. Remove all extra options, such as disk drives, one at a time, checking its affect on the server.
- e. Unplug the power cords, wait 20 seconds, plug the power cords in again, and restart the server.
- f. If you suspect a hardware error:
 1. Log users off the LAN and power down the server.
 2. Simplify the server to the minimum configuration.
- g. Remove all third-party options, and reinstall each one, one at a time, checking the server after each installation.
- h. Boot the server and if it does not function properly, refer to the following procedures.

The Server Does Not Power On

To check for power-related problems, use the checklist below:

- a. Check the LED for each bulk power supply (BPS).
The LED is located in the lower left-hand corner of the power supply face. Table 5-2 shows the states of the LEDs.
- b. Check that the power supply and a minimum of two power cords are plugged into the chassis.

NOTE Two power cords must be connected to A0 and A1 or B0 and B1.

- c. Remove and replace any suspect BPS.

The Server Powers On But Then Shuts Down with a Fault Light

For problems when the server powers on and then off, use the following checklist:

- a. Check for fault LEDs and check the MP logs for errors.
- b. Check that a conductive item has not been dropped or left inside the server chassis.
- c. Check the connections on all boards.
- d. Check the cables for bent pins.
- e. Check the processors for bent pins if processors were just added and the problem has been isolated to the cell board.
- f. Minimize configuration to isolate a potential bad device.

The Server Powers On But Fails Power-On Self Test

Use this checklist when the server fails power on self test (POST):

- a. Check for error messages on the system console.
- b. Check for fault LEDs.
- c. Check for error messages in the MP logs.

Server LED Indicators

The server has LEDs that indicate system health. This section defines those LEDs.

Front Panel LEDs

There are seven LEDs located on the front panel.

Figure 5-1 Front Panel with LED Indicators

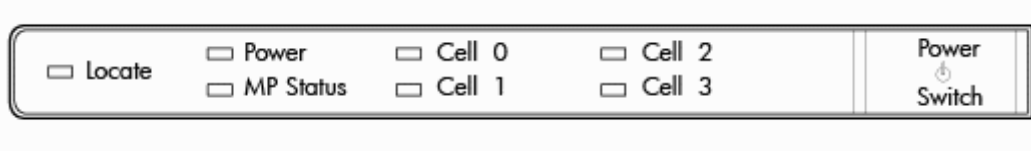

Table 5-1 Front Panel LEDs

LED	Status	Description
Power	On Green	48 V Good. (LED works even if MP is not installed, or installed and not active)
	Off	48 V Off
MP Status	Green (solid)	At least one MP is installed and active
	Off	No MPs are installed or at least one is installed but not active
	Red (flashing)	Cabinet overtemp condition exists
	Red (solid)	Cabinet shutdown for thermal reasons
	Yellow (flashing)	Cabinet fan slow or failed, master slave failover.
Yellow (solid)	FPGA detects no MPs present or functioning	

Table 5-1 Front Panel LEDs (Continued)

LED	Status	Description
Cell 0 thru Cell 3	Green (solid)	Cell power on
	Off	Cell power off
	Red (solid)	Cell fault. Cell powered off due to power problem or HPMC/MC event from cell
	Yellow (flashing)	Cell fault warning Latches not latched, LPM not ready, VRMs reporting not good or OT Cell fan slow/failed
Locate	Blue (flashing)	User requests locator ON and specifies (1 - 72) hour off timeout. Default timeout is 24 hours.
	Off	Timeout. Or user requests locator off.

Bulk Power Supply LEDs

There is a single, three-color LED located on each bulk power supply.

Figure 5-2 BPS LED Location

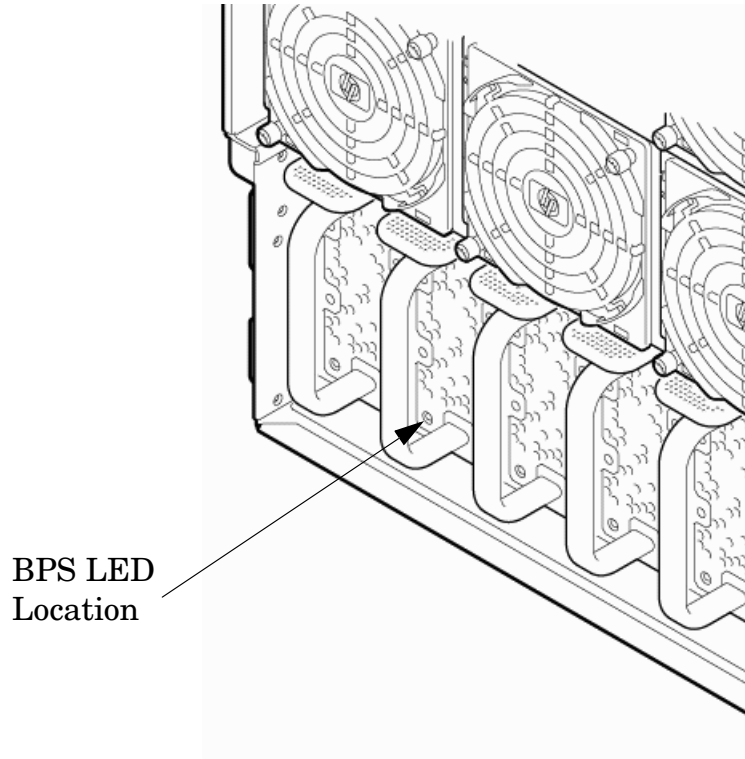

Table 5-2 BPS LEDs

LED Indication	Description
Blink Green	BPS in standby state and no faults or warnings
Green	BPS in run state (48 V output enabled) and no faults or warnings
Blink Yellow	BPS in standby or run state and warnings present but no faults
Yellow	BPS in standby state and recoverable faults present but no non-recoverable faults
Blink Red	BPS state may be unknown, non-recoverable faults present
Red	This LED state is not used
Off	BPS fault or failure, no power cords installed or no power to chassis

PCI Power Supply LEDs

There are three LEDs on the PCI power supply. Green and yellow LEDs follow OL* operation. A multi-color LED reports warnings and faults.

Figure 5-3 PCI Power Supply LED Locations

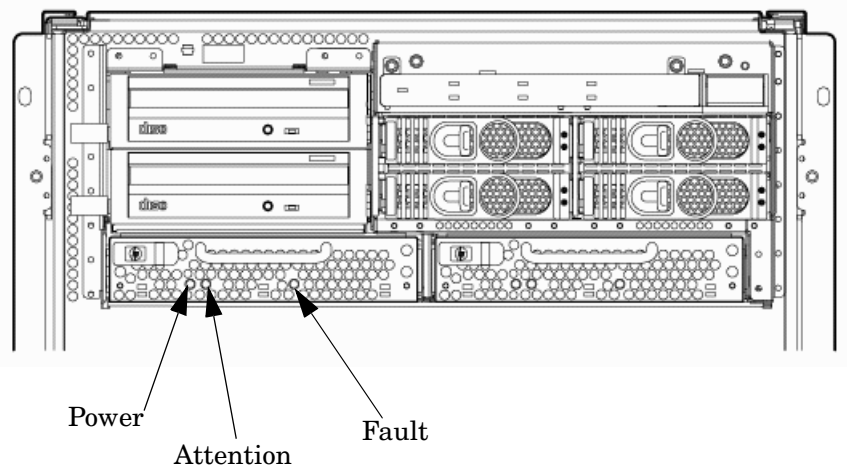

Table 5-3 PCI-X Power Supply LEDs

LED	Driven By	State	Description
Power	Each supply	On Green	All output voltages generated by the power supply are within limits.
		Off	Power to entire system has been removed.
Fault	Each supply	Flash Yellow	The temperature within the power supply is above the lower threshold.
		On Yellow	The temperature of the power supply is approaching the thermal limit
		Flash Red	Power supply has shut down due to an over temperature condition, a failure to regulate the power within expected limits, or a current-limit condition.
		Off	Normal operation.

System and I/O Fan LEDs

There is a single, three-color LED located on the front OLR fan, the rear OLR fan and the PCI I/O fan.

Figure 5-4 Fan LED Locations

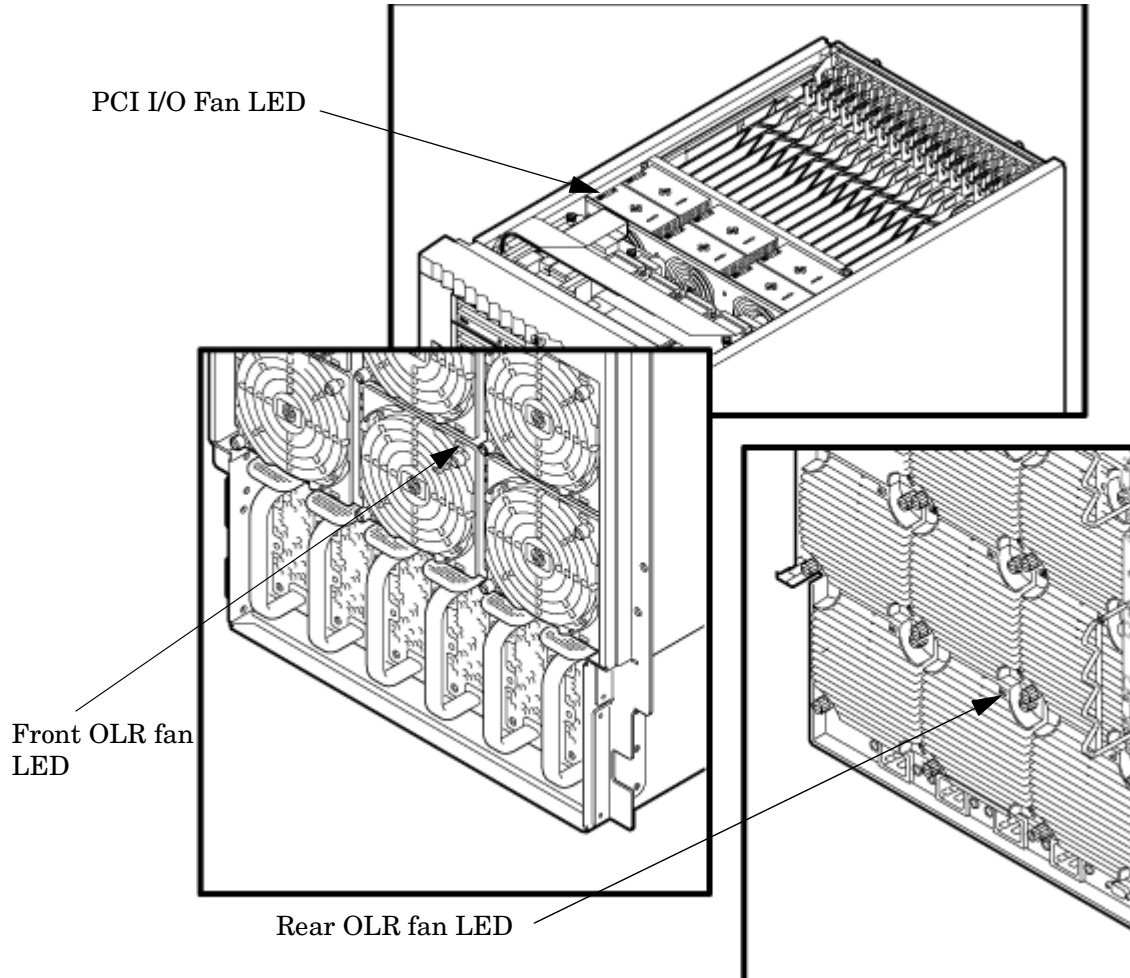

Table 5-4 Front, Rear, and I/O Fan LEDs

LED	Driven By	State	Description
Fan Status	Fan	Solid Green	Normal
		Flash Yellow	Predictive Failure
		Flash Red	Failed
		Off	No Power

OL* LEDs

Cell Board LEDs

There is one green power LED located next to each ejector on the cell board in the server that indicates the power is good. When the LED is illuminated green, power is being supplied to the cell board and it is unsafe to remove the cell board from the server.

There is one yellow attention LED located next to each ejector lever on the cell board in the server. When the yellow attention LED is flashing, it is safe to remove the cell board from the server.

Figure 5-5 Cell Board LED Locations

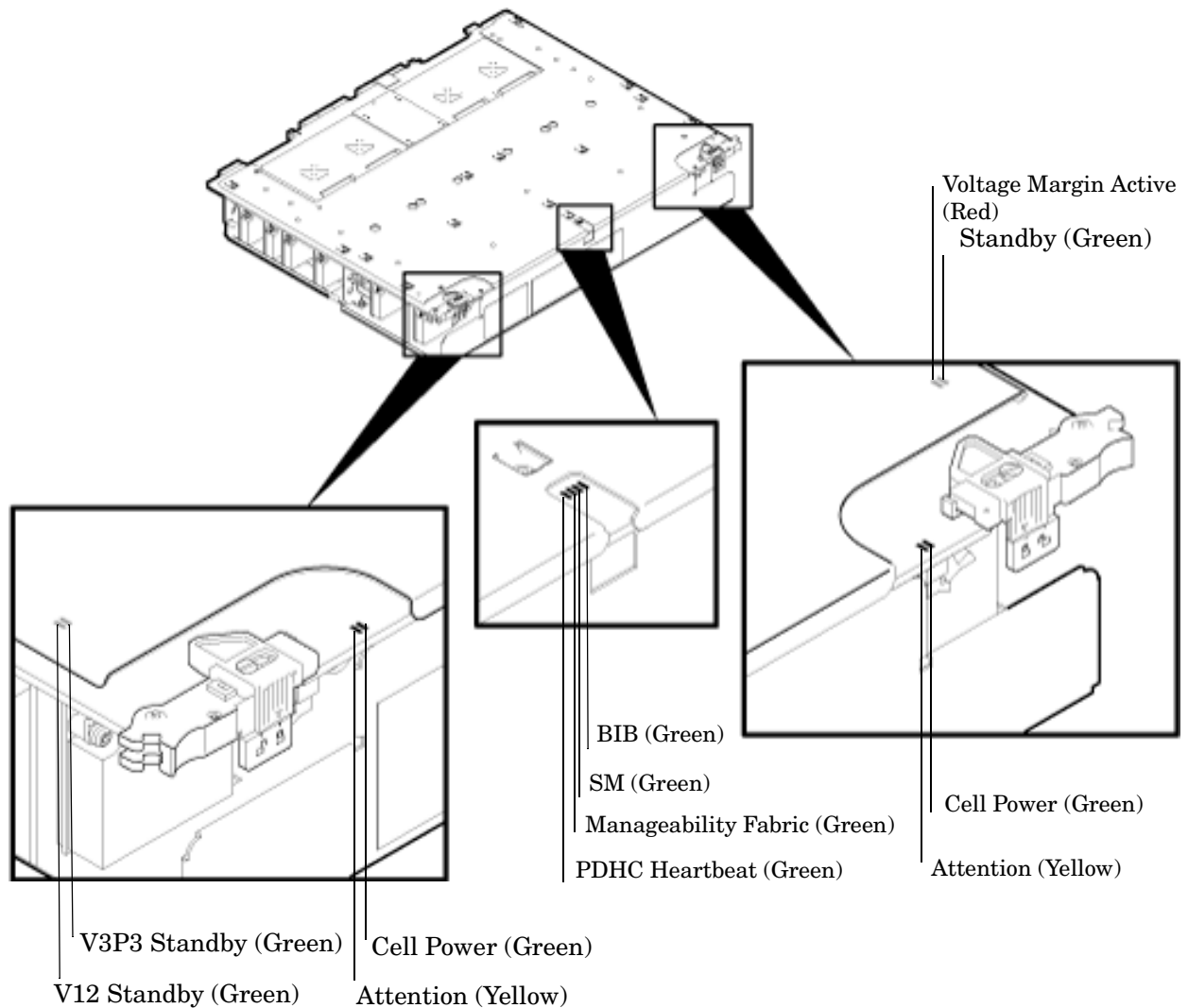

Table 5-5 Cell Board OL* LED Indicators

Location	LED	Driven by	State	Description
On cell board (located in the server cabinet)	Power	Cell LPM	On Green	3.3 V Standby and Cell_Power_Good
			Off	3.3 V Standby off, or 3.3 V Standby on and no Cell_Power_Good
	Attention	MP via GPM	Flash Yellow	Safe to remove the cell board from the system

PCI OL* Card Divider LEDs

The PCI-X OL* card LEDs are located on each of the 16 PCI-X slot dividers in the PCI-X card cage assembly area. The green power LED indicates whether power is supplied to the card slot. The yellow attention LED states are defined in Table 5-6.

Figure 5-6 PCI OL* LED Locations

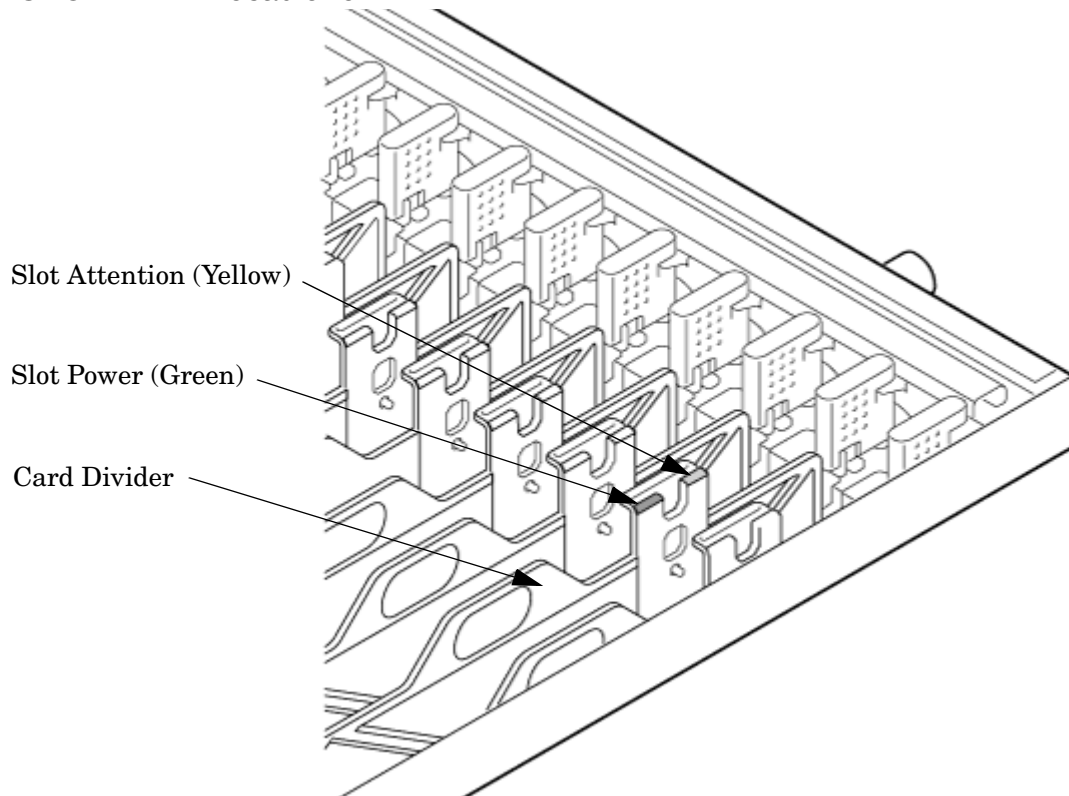

Table 5-6 OL* LED States

State	Power (Green)	Attention (Yellow)
Normal operation, slot power on	On	Off
Slot selected, slot power on	On	Flashing
Slot needs attention, slot power on	On	On
Slot available, slot power off	Off	Off
Ready for OL*, slot power off	Off	Flashing
Fault detected, slot power off	Off	On
Slot powering down or up	Flashing	Off

Core I/O LEDs

The core I/O LEDs are located on the bulkhead of the installed core I/O PCA. See Table 5-7 on page 168 to determine status and description. There is a DIP switch on the core I/O card that is used to select which MP firmware set (indicated by the MP SEL LED) is selected for loading. The DIP switch is only visible when the core I/O card is removed from the system and is located in the center of the PCA.

Figure 5-7 Core I/O Card Bulkhead LEDs

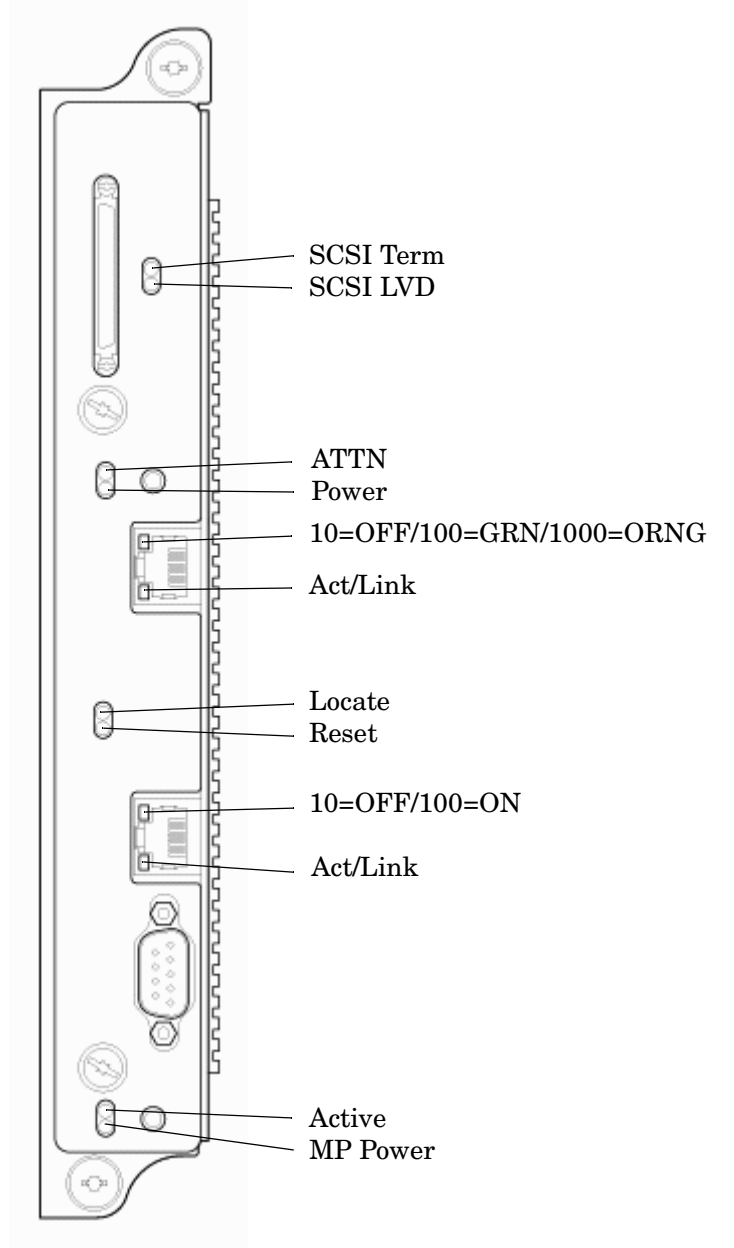

Table 5-7 Core I/O LEDs

LED (as silk-screened on the bulkhead)	State	Description
SCSI TRM	On Green	SCSI termpower is on
SCSI LVD	On Green	SCSI LVD mode (on = LVD, off = SE)
ATTN	On Yellow	PCI attention
PWR	On Green	I/O power on
SYS LAN 10 BT	On Green	SYS LAN in 10 BT mode
SYS LAN 100 BT	On Green	SYS LAN in 100 BT mode
SYS LAN 1Gb	On Green	SYS LAN in 1Gb mode
SYS LAN ACT	On Green	Indicates SYS LAN activity
SYS LAN LINK	On Green	SYS LAN link is ok
Locate	On Blue	Locater LED
Reset	On Red	Indicates that the MP is being reset
MP LAN 10 BT	On Green	MP LAN in 10 BT mode
MP LAN 100 BT	On Green	MP LAN in 100 BT mode
MP LAN ACT	On Green	Indicates MP LAN activity
MP LAN LINK	On Green	MP LAN link is OK
Active	On Green	This core I/O is managing the system
MP Power	On Green	Indicates standby power is on

Core I/O Buttons

There are two recessed buttons on the back of the core I/O card, as explained in Table 5-8.

Figure 5-8 Core I/O Button Location

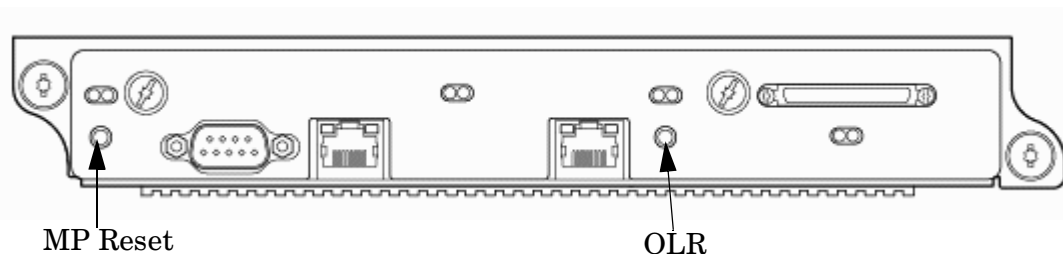



Table 5-8 Core I/O Buttons

Button Identification (as silk-screened on the bulkhead)	Location	Function
MP RESET	To the far left side of the core I/O card	Resets the MP NOTE: If the MP RESET button is held for longer than five seconds, it will clear the MP password and reset the LAN, RS-232 (serial port), and modem port parameters to their default values. LAN Default Parameters <ul style="list-style-type: none"> • IP Address - 192.168.1.1 • Subnet mask - 255.255.255.0 • Default gateway - 192.168.1.1 • Hostname - gsp0 RS-232 (Serial Port) Default Parameters <ul style="list-style-type: none"> • 9600 baud • 8 bits • No parity Remote/Modem Port Parameters <ul style="list-style-type: none"> • Disabled
OLR (Symbol next to button is shown below) 	To the far right side of the core I/O card	Request OL* for this core I/O slot NOTE: The OLR function is not enabled for the core I/O card.

Disk Drive LEDs

There are two tri-color LED on each disk drive.

Figure 5-9 Disk Drive LED Location

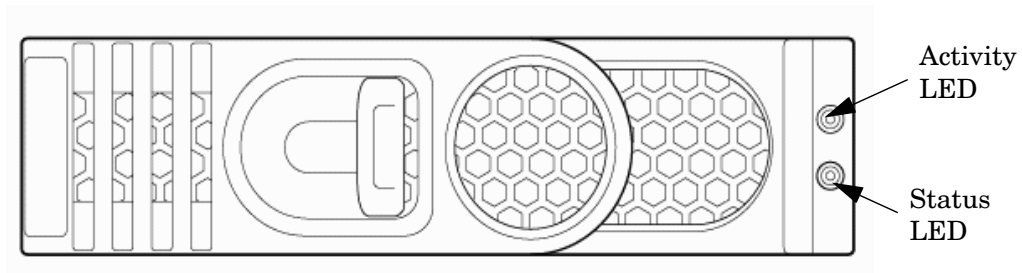

Table 5-9 Disk Drive LEDs

Activity LED	Status LED	Flash Rate	Description
Off	Green	Steady	Normal operation, power applied
Green	Off	Steady	Green stays on during foreground drive self-test
Green	Off	Flutter at rate of activity	I/O Disk activity
Off	Yellow	Flashing at 1Hz or 2 Hz	Predictive failure, needs immediate investigation
Off	Yellow	Flashing at 0.5Hz or 1Hz	Operator inducing manually
Off	Yellow	Steady	Module fault, critical
Off	Off	LEDs off	Unit not powered or installed

Interlock Switches

There are three interlock switches located in the server. Both side covers and the top cover have an interlock switch located underneath each cover.

- **Side Covers**—If either side cover is removed while the system is powered on, the system fans on the front and rear increase in speed to ensure adequate cooling. An event code is generated to indicate a side cover was removed.
- **Top Cover**—If the top cover is removed while the system power is on, the PCI-X card cage assembly I/O fan speed will not change. An event code is generated to indicate the top cover was removed.

Server Management Subsystem Hardware Overview

Server management for the servers is provided by the MP on the core I/O board. The server management hardware is powered by standby power that is available whenever the server is plugged into primary AC power. This allows service access even if the DC power to the server is switched off.

The management processor communicates with the server subsystems, sensors, and platform dependent code (PDC) by internal buses. It also communicates with the operating console by virtual universal asynchronous receiver-transmitters (UARTs) on the cell board.

Connection to the management processor is by way of two I/O paths:

- An RS-232 port for a local terminal
- A 10/100 baseT LAN port (Web console)

NOTE There is no modem support for MP access.

When the server is configured with one core I/O board, that board must be in slot 0, since the master management processor is always the MP on the core I/O board in slot 0.

When the server is configured for two partitions, it must contain two core I/O boards, one for each partition. It will also contain two MPs. In this case, the MP in slot 0 is the master MP and provides all of the server management functions. All external connections to the MP must be to the master MP in slot 0. The slave MP ports will be disabled.

Booting HP-UX with a failed core I/O card is possible, as the console UARTs are located on the cell board.

The server configuration may not be changed without the MP.

In the event of a master MP failure, the slave MP automatically becomes the master MP, allowing continued access to the manageability subsystem.

Server Management Overview

Server management consists of four basic functional groups:

- Chassis management
- Chassis logging
- Console and session redirection
- Service access

Chassis Management

Chassis management consists of control and sensing the state of the server subsystems:

- Control and sensing of bulk power
- Control and sensing of DC-to-DC converters
- Control and sensing of fans
- Control of the front panel LEDs
- Sensing temperature
- Sensing of the power switch
- Sensing chassis intrusion
- Reading FRU PROMS

Chassis Logging

Chassis logging consists of maintaining logs of chassis codes:

- Boot codes
- Activity codes
- Error codes

Console and Session Redirection

Console and session redirection allows the console and session terminals to be connected over RS-232, a modem, or a LAN connection (Web console).

Service Access

Service access allows access to and control of server state. Service access is secured by a password. Service access functions include:

- Access to chassis logs
- Configuration of partitions
- Control for online addition and replacement
- Access to the virtual front panel
- Transfer of control and reset

Server Management Behavior

This section describes how the system responds to over-temperature situations, how the firmware controls and monitors fans, and how it controls power to the server.

Thermal Monitoring

The manageability firmware is responsible for monitoring the ambient temperature in the server and taking appropriate action if this temperature becomes too high. To this end, the ambient temperature of the server is broken into four ranges: normal, overtemp low (OTL), overtemp medium (OTM), and overtemp high (OTH). Figure 5-10 shows the actions taken at each range transition. Actions for increasing temperatures are shown on the left; actions for decreasing temps are shown on the right.

Figure 5-10 Temperature States

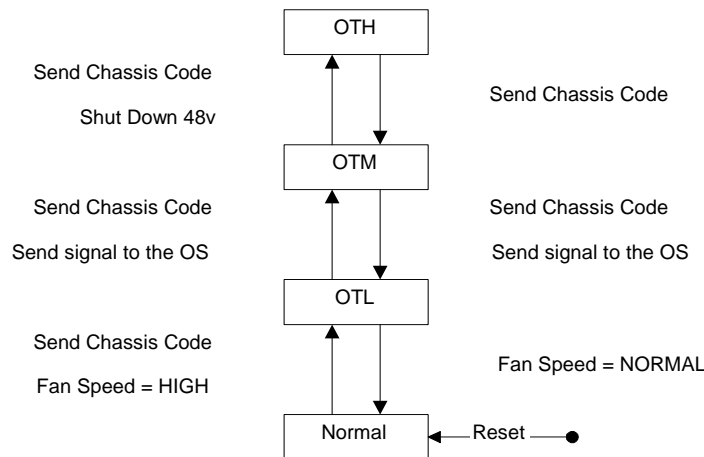

On large temperature swings, the server will transition through all states in order. It may go to the following state immediately, but each of the preceding actions will occur. If the temperature reaches the highest range, the server will be shut down immediately by the manageability firmware.

Fan Control

There are three sets of fans in the system: those on the I/O bay, the front and rear fans that are connected to the main backplane, and those on the cell boards. The front fans are run off of standby power, and will be running any time AC input power is supplied to the server. All of the fans turn on when 48 V power is supplied to the system.

As shown Figure 5-10, the fan behavior is related to the temperature state. The fans will be set to high speed when the ambient temperature is anywhere above the normal operating range. The front and rear fans will be set to high speed any time a chassis intrusion switch is triggered when removing a side cover.

Altimeter Circuit

The PCI-X backplane contains an altimeter circuit. This circuit is used to adjust the chassis fan speeds for the operating altitude at power on and during MP initialization. The chassis fans consist of the nine front fans, the twelve rear fans, and the six PCI-X I/O assembly fans. If an altimeter failure is detected, the information is logged as an Event ID then propagated to the OS level to be picked up by monitoring diagnostics.

The altimeter circuit is checked at power on by the MP. If an expected value is returned from the altimeter circuit, the altimeter is determined good. The altimeter reading is then set in non-volatile random access memory (NVRAM) on board the core I/O card. If the value is ever lost like for a core I/O replacement, the NVRAM will be updated at next boot provided the altimeter is functioning normally. If the altimeter has failed, and the stable storage value has been lost because of a core I/O failure or replacement, the MP will adjust the fan speeds for sea level operation.

NOTE Fans driven to a high RPM in dense air cannot maintain expected RPM and will be considered bad by the MP leading to a “False Fan Failure” condition.

Power Control

If active, the manageability firmware is responsible for monitoring the power switch on the front panel. Setting this switch to the ON position is a signal to the MP to turn on 48 V DC power to the server. The PE command can also be used to send this signal. This signal does not always generate a transition to the powered state. The following conditions prevent the manageability firmware from applying 48 V DC power to the server:

- Insufficient number of active bulk power supplies
- Insufficient number of I/O fans
- Insufficient number of main fans
- Ambient temperature is in an OVERTEMP HIGH condition

Unless one of the following conditions occurs, 48 V DC power to the server is maintained:

- A main fan failure causes there to be an insufficient number of main fans.
- A I/O fan failure causes there to be an insufficient number of I/O fans.
- Ambient temperature reaches an OVERTEMP HIGH condition.
- The front panel power switch is turned OFF.
- The PE command is issued to the manageability firmware to turn off power to the server cabinet.

Updating Firmware

The following sections describe how to update firmware using either HP Firmware Manager (HP FM) or FTP.

Firmware Manager

You can update firmware by using the HP Firmware Manager (HP FM). HP FM is a set of tools for updating firmware on an Integrity or PA-RISC system. HP FM is packaged with firmware and distributed through the web.

HP FM provides two methods of updating firmware. The method to use depends on whether or not the operating system is running on the target system:

- **HP OS–Initiated Firmware Manager (HP OSIFM)** — Use HP OSIFM if the HP-UX, Linux, or Windows operating system is running on the target system. HP OSIFM provides a firmware package in a patch or product file for HP-UX and a Smart Component for Windows and Linux. You download the patch, product, or Smart Component to a system, and then use the operating system to update the firmware.
- **HP Offline Firmware Manager (HP OFM)** — Use HP OFM if the operating system is not running on the target system, or to update the firmware for a device in the boot path. HP OFM provides a firmware package as an .ISO image that you download to a system to create a CD. You then use the CD to boot the system and update the firmware. HP OFM is available only for Integrity systems.

For more procedures on downloading and updating firmware using FM, see the HP Firmware Managers User's Guide at: <http://docs.hp.com/en/hw.html>.

Using FTP to Update Firmware

The following section contains instructions for using FTP to update firmware.

- The user logs in to the server console through the LAN, local serial, or remote serial locations.
- The user types the `FW` command to start the firmware update.

NOTE The LAN configuration for the server must be set for the FTP connection to function correctly regardless of whether the console LAN, local serial, or other connection is used to issue the `FW` command.

FW – Firmware Update

- Access Level: Administrator
- Scope: Complex
- Description: This command prompts the user for the location of the firmware software and the FLASH handle (from a list) which represents all upgradeable entities.

Figure 5-11 illustrates the output and questions requiring responses. After the user replies `y` to the confirmation request, the firmware update makes the connection to the FTP server at the IP address given using the user and password details supplied. The appropriate files will be downloaded and burned into the selected flash memories. Note that the firmware update validates the image to determine that the image name supplied is that of a valid image type before burning the image into the flash memory.

CAUTION Instructions for updating the firmware are contained in the firmware release notes for each version of firmware. The procedure should be followed exactly for each firmware update otherwise the system could be left in an unbootable state. Figure 5-11 should not be used as an upgrade procedure and is provided only as an example.

Figure 5-11 Firmware Update Command Example

```
Current Server Settings:
  Server           : 15.11.130.234
  FW Source Directory : kmix_pa_2.1D
  User Name        : fwupdate

Update firmware from this source? ([Y]/N) y

Enter password:   ERROR: Cannot connect to server!

Current Server Settings:
  Server           : 15.11.130.234
  FW Source Directory : kmix_pa_2.1D
  User Name        : fwupdate

Update firmware from this source? ([Y]/N)

Enter password:   ERROR: Cannot connect to server!
```

Possible Error Messages

- Could not ping host
- Could not validate cyclic redundancy check (CRC) of packet
- Could not find firmware update
- Invalid password

PDC Code CRU Reporting

The processor dependent code (PDC) interface defines the locations for the CRUs. These locations are denoted in the following figures to aid in physically locating the CRU when the diagnostics point to a specific CRU that has failed or may be failing in the near future.

Figure 5-12 Server Cabinet CRUs (Front View)

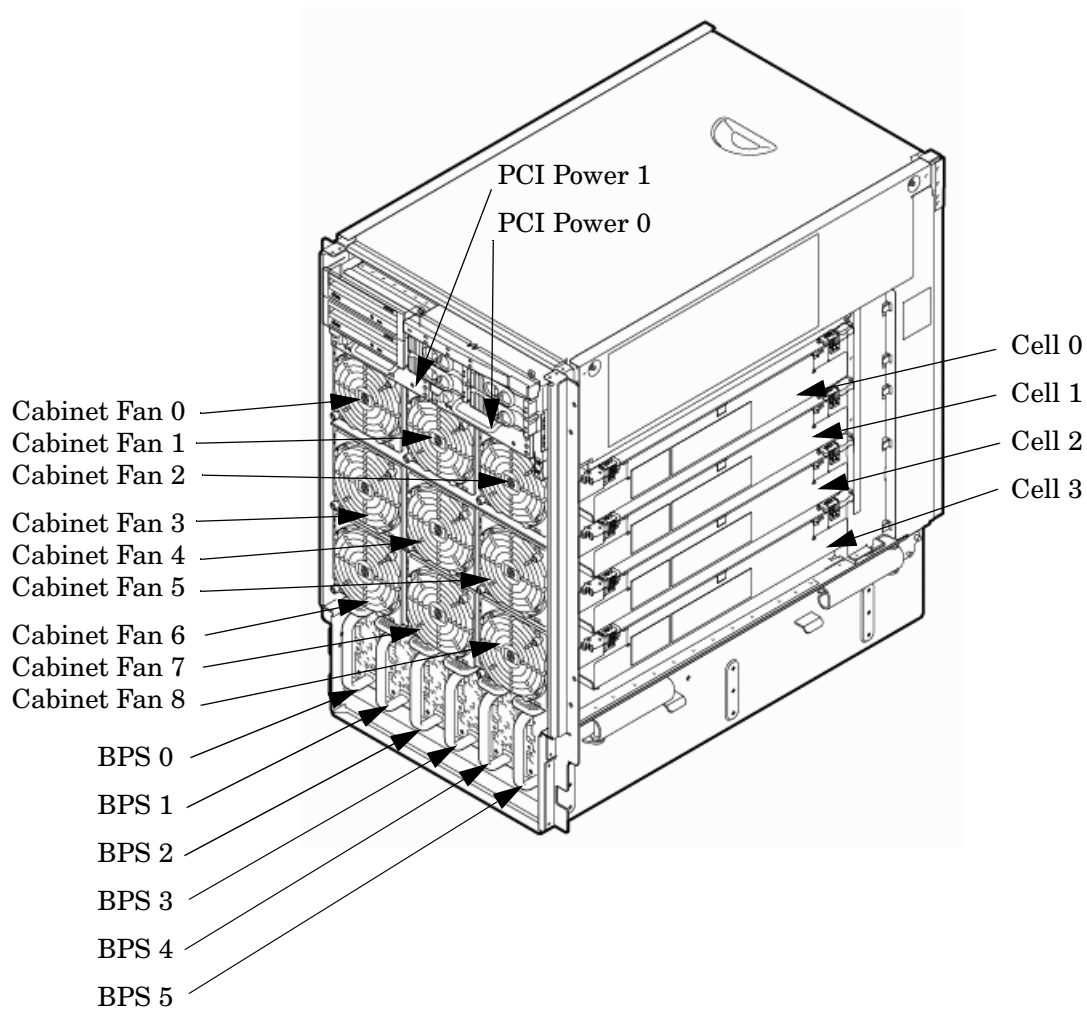
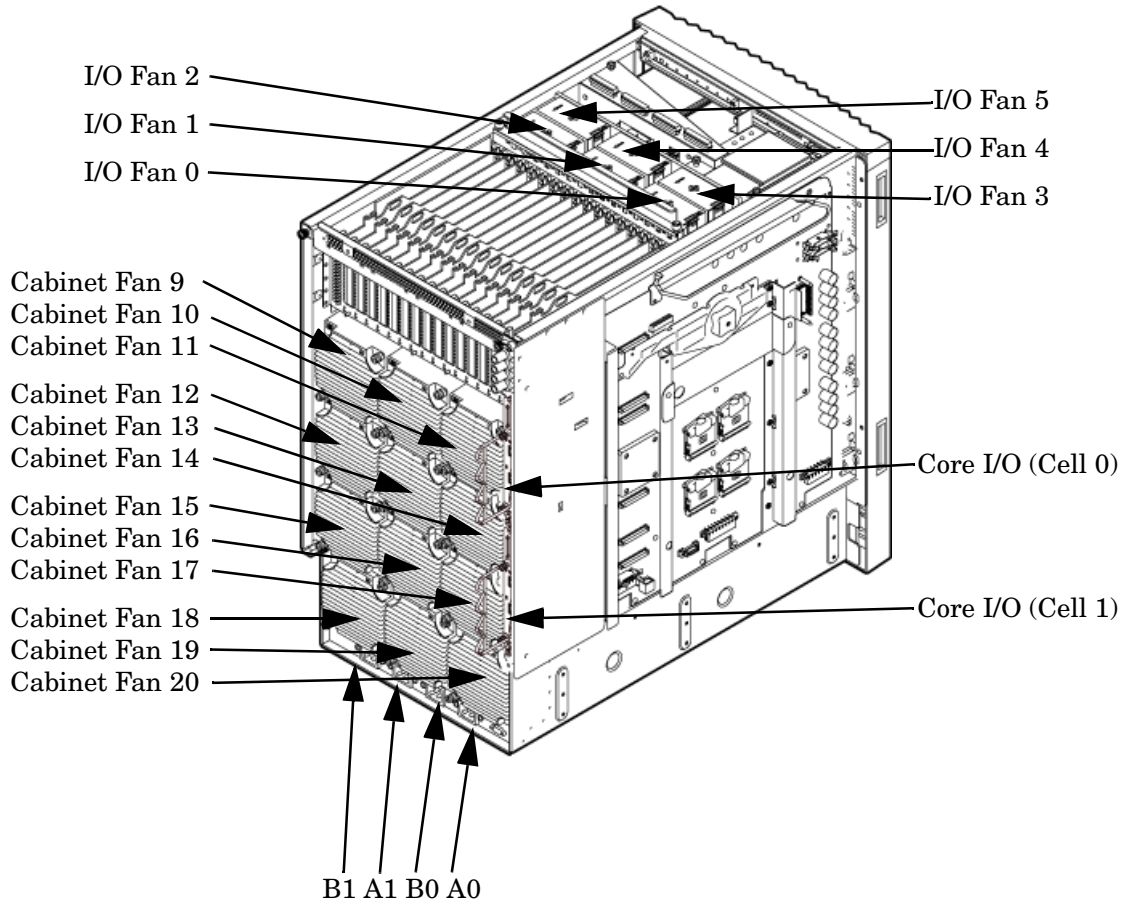

Figure 5-13 Server Cabinet CRUs (Rear View)



6 Removing and Replacing Components

This chapter provides a detailed description of the server field replaceable unit (CRU) removal and replacement procedures.

The procedures in this chapter are intended for use by trained and experienced HP service personnel only.

Customer Replaceable Units (CRUs)

The following section lists the different types of CRUs the server supports.

Hot-Plug CRUs

A CRU is defined as hot-plug if it can be removed from the chassis while the system remains operational, but requires software intervention before it is removed.

The following are remove and replace procedures for hot-plug CRUs:

- Removing and Replacing a Disk Drive
- Removing and Replacing a PCI Card

Hot-Swap CRUs

A CRU is hot-swap if it can be removed from the chassis while the server remains operational and requires no software intervention before it is removed.

The following list identifies procedures for removing and replacing the hot-swap CRUs in the server.

- Removing and Replacing the PCI Power Supply
- Removing and Replacing the Front Smart Fan Assembly
- Removing and Replacing the Rear Smart Fan Assembly
- Removing and Replacing a Bulk Power Supply (BPS)

Safety and Environmental Considerations

WARNING Before proceeding with any installation, maintenance, or service on a system that requires physical contact with electrical or electronic components, be sure that either power is removed or safety precautions are followed to protect against electric shock and equipment damage. Observe all WARNING and CAUTION labels on equipment. All installation and service work must be done by qualified personnel.

WARNING Before proceeding with any installation, maintenance, or service on a system that requires physical contact with electrical or electronic components, be sure that either power is removed or safety precautions are followed to protect against electric shock and equipment damage. Observe all WARNING and CAUTION labels on equipment. All installation and service work must be done by qualified personnel.

Communications Interference

HP system compliance tests are conducted with HP supported peripheral devices and shielded cables, such as those received with the system. The system meets interference requirements of all countries in which it is sold. These requirements provide reasonable protection against interference with radio and television communications.

Installing and using the system in strict accordance with HP instructions minimizes the chances that the system will cause radio or television interference. However, HP does not guarantee that the system will not interfere with radio and television reception.

Take these precautions:

- Use only shielded cables.
- Install and route the cables according to the instructions provided.
- Ensure that all cable connector screws are firmly tightened.
- Use only HP supported peripheral devices.
- Ensure that all panels and cover plates are in place and secure before system operation.

Electrostatic Discharge

HP systems and peripherals contain assemblies and components that are sensitive to electrostatic discharge (ESD). Carefully observe the precautions and recommended procedures in this document to prevent component damage from static electricity.

CAUTION Connect to ground with a wrist strap. You can connect to any grounded metal assembly in the cabinet. Both you and the electronic devices must be grounded to avoid static discharges that can cause damage.

Take these precautions:

Safety and Environmental Considerations

- Prepare an ESD-safe work surface large enough to accommodate the various assemblies handled during the upgrade. Use a grounding mat and an anti-static wrist strap, such as those included in the ESD Field Service Kit (9300-1609).
- The anti-static bag cannot function as a static dissipating mat. Do not use the anti-static bag for any other purpose than to enclose a product.
- Treat all assemblies, components, and interface connections as static-sensitive.
- When unpacking cards, interfaces, and other accessories that are packaged separately from the system, keep the accessories in the conductive plastic bags until you are ready to install them.
- Avoid working in carpeted areas, and keep body movement to a minimum while installing accessories.

Powering Off Hardware Components and Powering On the Server

When you remove and replace hardware, you might need to power off hardware components as part of the remove and replace procedure.

This section gives details on how to power the hardware components off and on.

Powering Off Hardware Components

To power off individual components or the entire cabinet:

Step 1. Log in to the management processor (MP) of the server.

Step 2. If the component you will power off is assigned to an nPartition, then use the Virtual Front Panel (VFP) to view the current boot state of the nPartition.

Shut down HP-UX on the nPartition down before you power off any of the hardware assigned to the nPartition. Refer to Chapter 4 “Operating System Boot and Shutdown.”

When you are certain the nPartition is not running HP-UX, you can power off components that belong to the nPartition.

Refer to Chapter 4, “Operating System Boot and Shutdown” for details on determining the nPartition boot state and shutting down HP-UX.

Step 3. Access the MP Command menu.

From the MP Main Menu, enter `CM` to access the Command menu.

Step 4. Use the MP Command Menu `PS` command to check details about the hardware component you plan to power off.

The `PS` command enables you to check the status of the cabinet, system backplane, MP core I/O, PCI power domains—or bricks—in the I/O card cage and cells.

Step 5. Use the MP Command Menu `PE` command to power off the hardware component.

Using the `PE` command, you can power on or off the cabinet (including all cells and I/O in the cabinet), individual cells along with their associated I/O domain, or PCI power domains (bricks).

Using the Command Menu `PE` command to manage cabinet power is equivalent to using the front panel power switch.

IMPORTANT Because of power redundancy capabilities, it is important to plug each power cord into its proper receptacle. Label each power cord to indicate its correct receptacle.

WARNING Ensure that the cabinet power has been turned off before disconnecting any power cords.

Step 6. To disable *all power* in the entire cabinet, disconnect all power cords to disable all housekeeping power.

Step 7. Perform the hardware removal and replacement procedure for the powered-off component.

Powering On the System

To power on the system after a repair:

- Step 1.** If needed, reconnect all power cords to the appropriate receptacles and power on the system.
- Step 2.** Use the MP Command Menu `PE` command to power on the hardware component that was powered off and replaced.
- Step 3.** Use the `PS` command to verify that power is enabled to the newly replaced part. For example: Enter `C` from within the `PS` command to select cell.

If power is absent from the part, enter the `PE` command and select `T` to power on the entire cabinet.

NOTE You may need to allow time for some components to complete a power on self-test (POST) before a complete status is available.

- Step 4.** Reboot each nPartition. Refer to Chapter 4 “Operating System Boot and Shutdown”.
- Step 5.** Verify system functionality by using the Online Diagnostic Support Tools Manager (STM) exerciser.

Removing and Replacing Covers

It is necessary to remove one or more of the covers (Figure 6-1) to access many of the CRUs within the server chassis.

CAUTION Observe all electrostatic discharge (ESD) safety precautions before attempting these procedures. Failure to follow ESD safety precautions can result in damage to the server.

Figure 6-1 Cover Locations

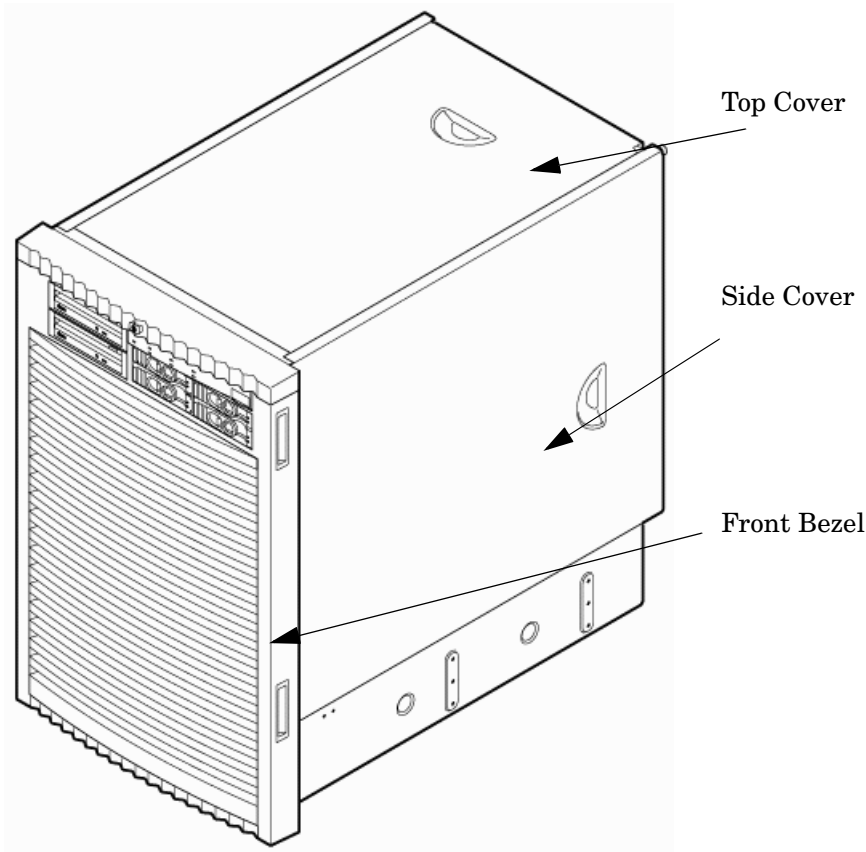

Removing the Top Cover

- Step 1.** Connect to ground with a wrist strap. Refer to “Electrostatic Discharge” on page 182 for more information.
- Step 2.** Loosen the retaining screws securing the cover to the chassis. Refer to Figure 6-2.
- Step 3.** Slide the cover toward the rear of the chassis.
- Step 4.** Lift the cover up and away from the chassis.

Step 5. Place the cover in a safe location.

Figure 6-2 **Top Cover Removed**

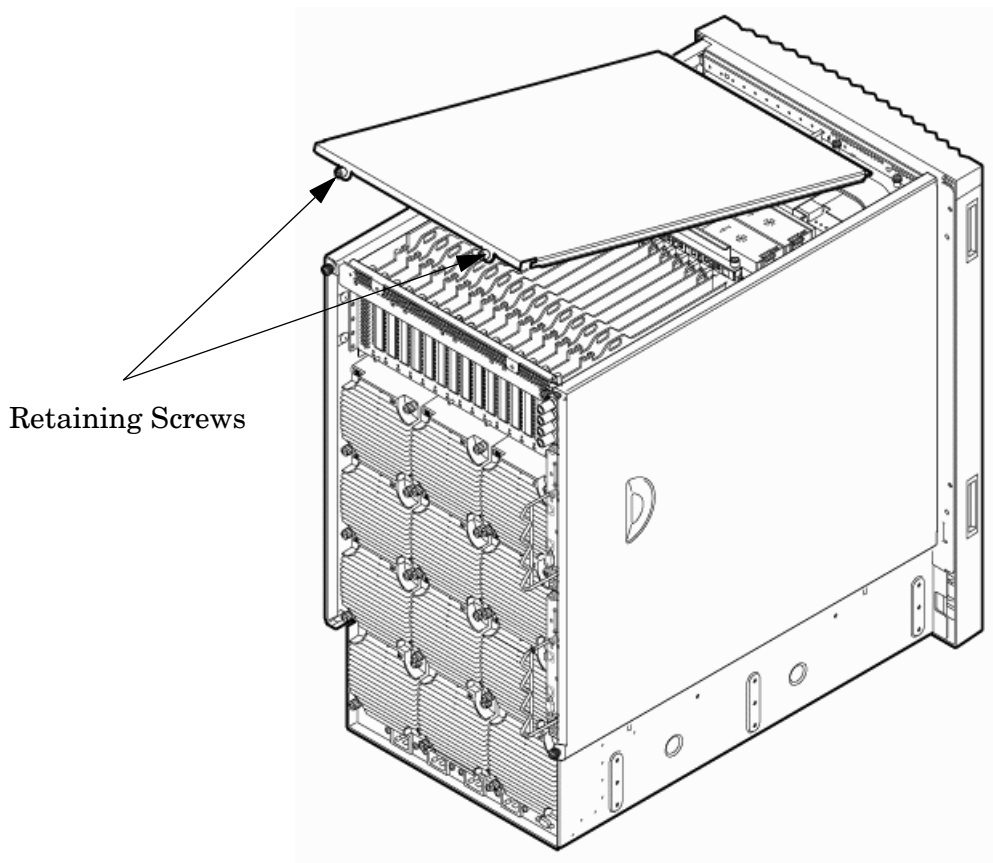

Replacing the Top Cover

Step 1. Orient the cover on the top of the chassis.

NOTE Carefully seat the cover to avoid damage to the intrusion switch.

Step 2. Slide the cover into position using a slow, firm pressure to properly seat the cover.

Step 3. Tighten the blue retaining screws securing the cover to the chassis.

Removing the Side Cover

Step 1. Connect to ground with a wrist strap. Refer to “Electrostatic Discharge” on page 182 for more information.

Step 2. Loosen the blue retaining screw securing the cover to the chassis. Refer to Figure 6-3.

Figure 6-3Side Cover Removal Detail

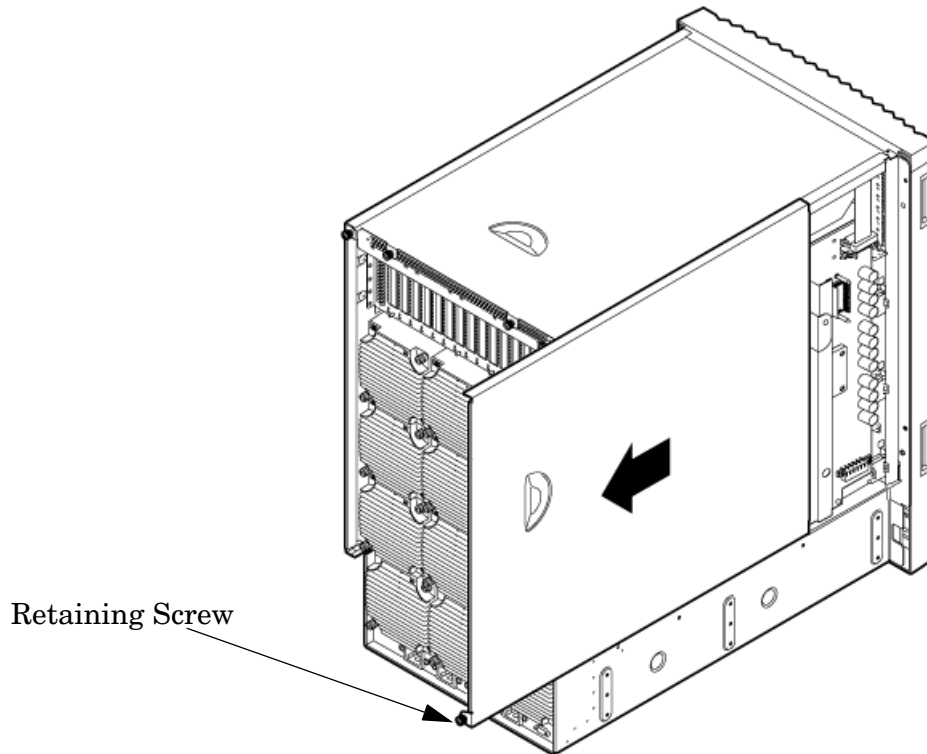

Step 3. Slide the cover from the chassis toward the rear of the system.

Step 4. Place the cover in a safe location.

Replacing the Side Cover

Step 1. Orient the cover on the side of the chassis.

Step 2. Slide the cover into position using a slow, firm pressure to properly seat the cover.

Step 3. Tighten the blue retaining screw securing the cover to the chassis.

Removing and Replacing the Front Bezel

To remove the front bezel:

From the front of the server, grasp both sides of the bezel and pull firmly toward you (Figure 6-4). The catches will release and the bezel will pull free.

Figure 6-4 Bezel Removal and Replacement

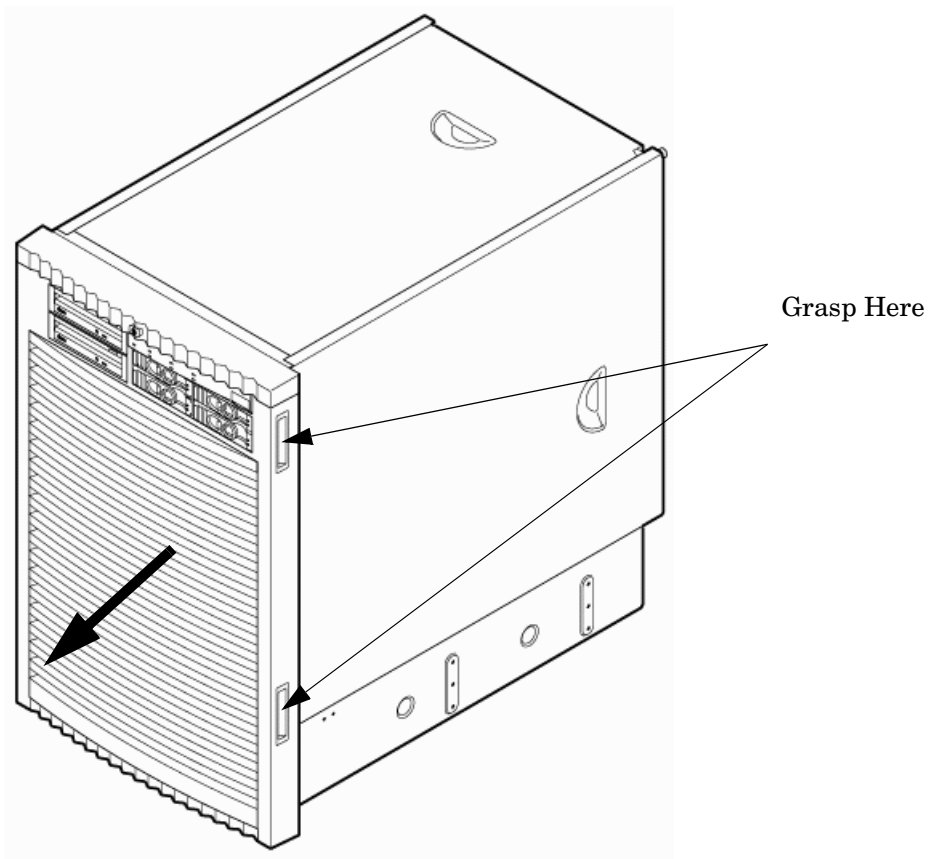

Replacing the Front Bezel

- Step 1.** If you are replacing the bezel, visually inspect the replacement part for the proper part number.
- Step 2.** From the front of the server, grasp both sides of the bezel and push toward the server. The catches will secure the bezel to the chassis.

Removing and Replacing the Front Smart Fan Assembly

The front smart fan assembly is located in the front of the chassis (Figure 6-5). The fan assembly is a hot-swap component. Refer to “Hot-Swap CRUs” on page 181 for a list and description of hot-swap CRUs.

Figure 6-5 Front Smart Fan Assembly Location

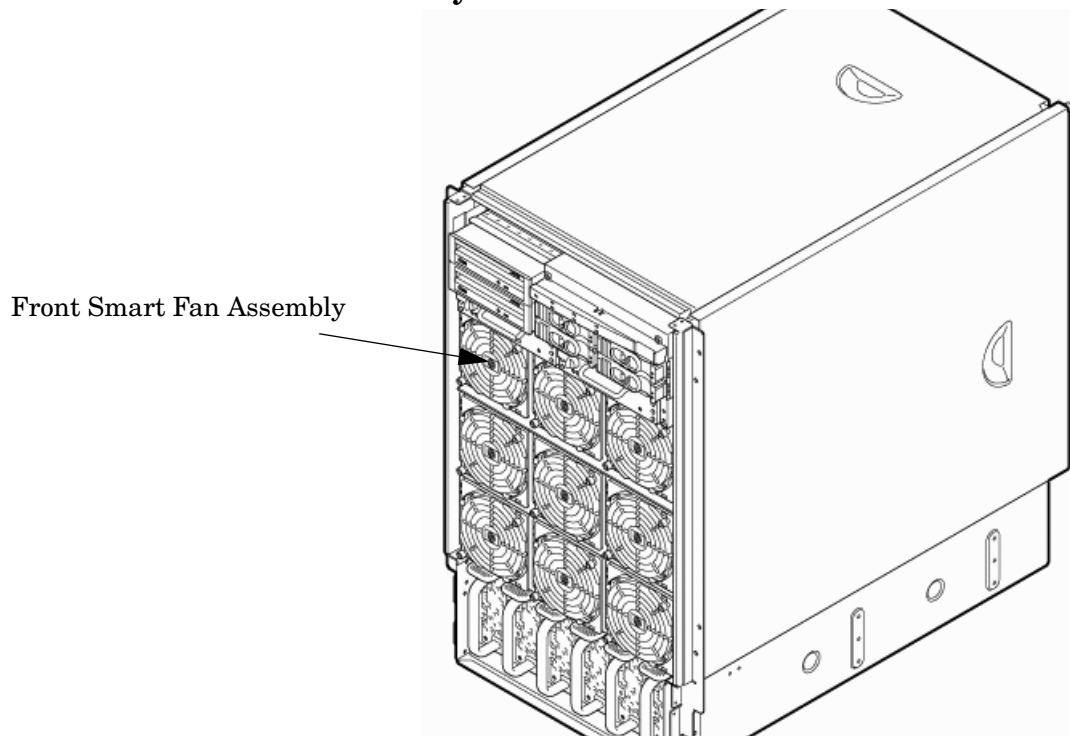

Removing the Front Smart Fan Assembly

Step 1. Remove the front bezel.

Step 2. Identify the failed fan assembly. Table 6-1 defines the fan LED states.

Table 6-1 Smart Fan Assembly LED States

LED State	Meaning
Green	Fan is at speed and in sync or not at speed less than 12 seconds.
Flash Yellow	Fan is not keeping up with speed/sync pulse for longer than 12 seconds.
Red	Fan failed, stalled or has run slow or fast for longer than 12 seconds.
Off	Fan is not present, no power is applied to fan, or the fan has failed.

Figure 6-6 Front Fan Removal

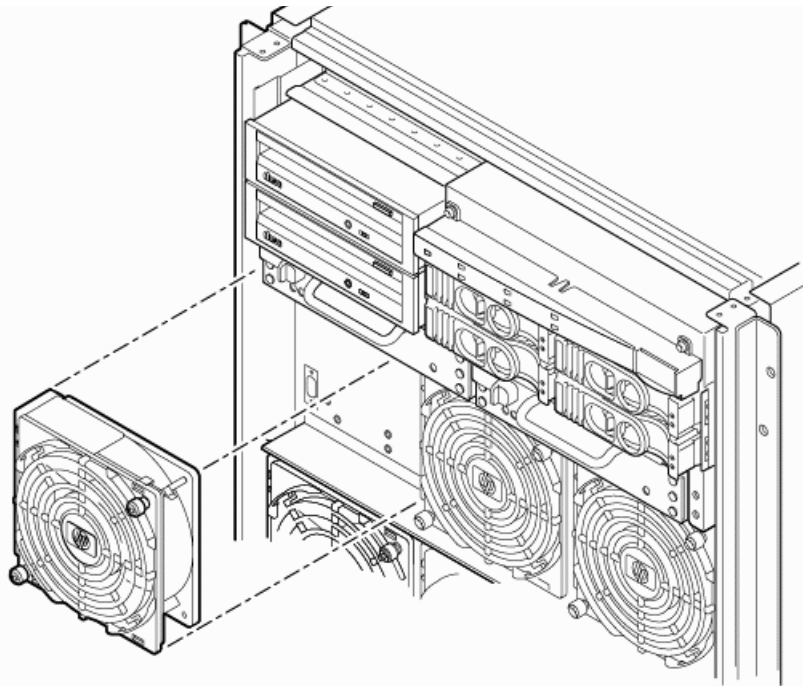

Step 3. Loosen the two thumb screws securing the fan to the chassis.

Step 4. Slide the fan from the chassis.

Replacing the Front Smart Fan Assembly

Step 1. Position the fan assembly in the chassis.

Step 2. Tighten the two thumb screws to secure the fan to the chassis.

Step 3. Check the fan status LED. It should be Green. Refer to Table 6-1 for LED definitions.

Step 4. Replace the front bezel.

Removing and Replacing the Rear Smart Fan Assembly

The rear smart fan assembly is located in the rear of the chassis (Figure 6-7). The fan assembly is a hot-swap component. Refer to “Hot-Swap CRUs” on page 181 for a list and description of hot-swap CRUs.

Figure 6-7 Rear Smart Fan Assembly Location

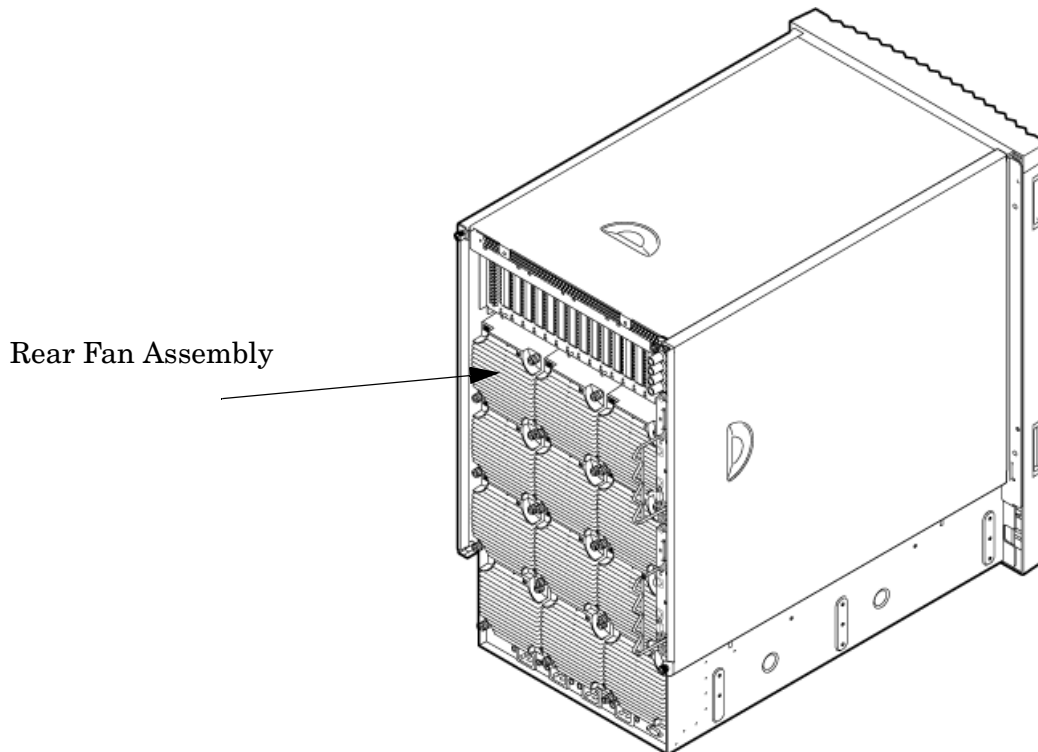

Removing the Rear Smart Fan Assembly

Step 1. Identify the failed fan assembly. Table 6-1 defines the fan LED states.

Step 2. Loosen the two thumb screws securing the fan to the chassis.

Step 3. Slide the fan from the chassis (Figure 6-8).

Figure 6-8Rear Fan Detail

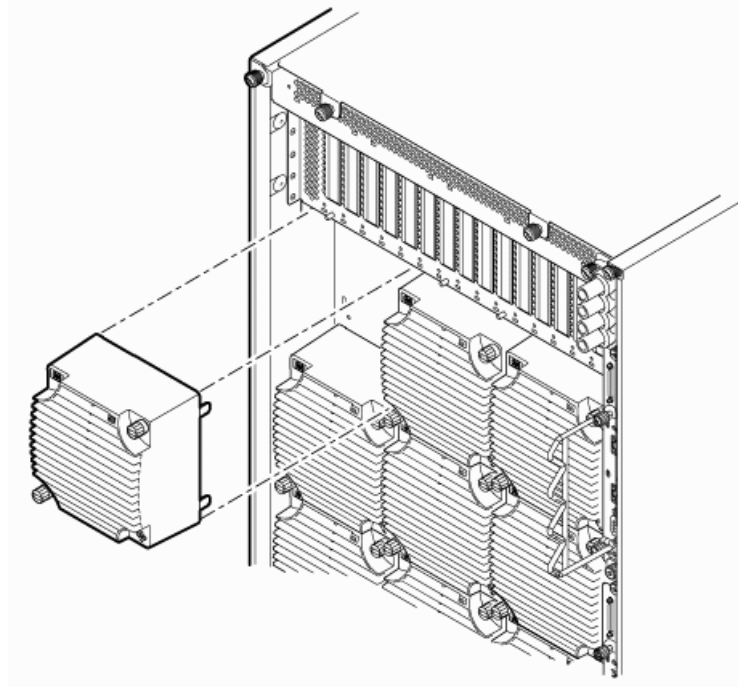

Replacing the Rear Smart Fan Assembly

Step 1. Position the fan assembly in the chassis.

Step 2. Slide the fan into the connector.

Step 3. Tighten the two thumb screws to secure the fan to the chassis.

Step 4. The LED should be Green. Refer to Table 6-1 for a listing of LED definitions.

Removing and Replacing a Disk Drive

The disk drive is located in the front of the chassis. Internal disk drives are hot-plug components. Refer to “Hot-Plug CRUs” on page 181 for a list and description of hot-plug CRUs.

Figure 6-9 **Disk Drive Location**

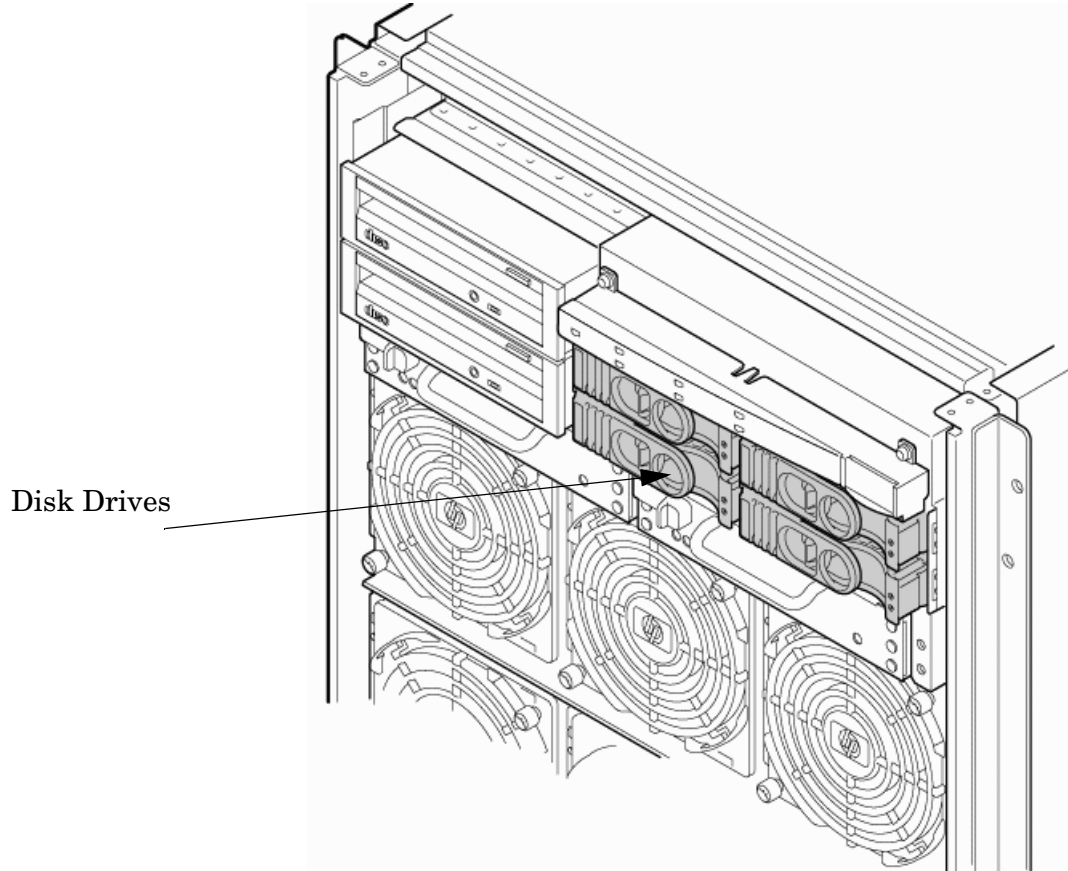

Removing the Disk Drive

- Step 1.** Disengage the front locking latch on the disk drive by pushing the release tab to the right and the latch lever to the left.

Step 2. Pull forward on the front locking latch and carefully slide the disk drive from the chassis (Figure 6-10),

Figure 6-10 **Disk Drive Detail**

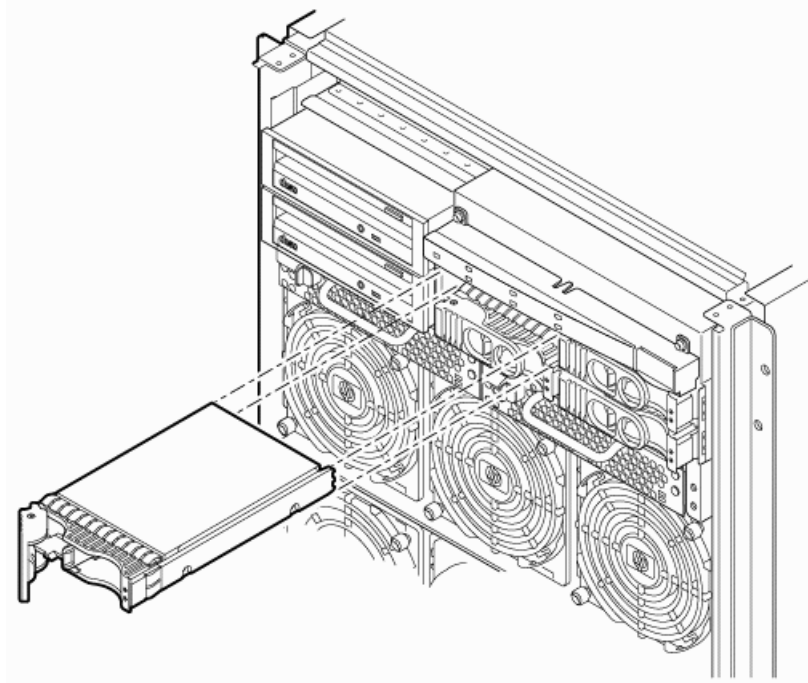

Replacing the Disk Drive

Step 1. Sometimes `diskinfo` and `ioscan` will display cached data. Running `diskinfo` on the device without a disk installed clears the cached data. Enter either of the following commands. For the `diskinfo` command, replace `x` with actual values.

- `#diskinfo -v /dev/rdisk/cxtxdx`
- `#ioscan -f`

Step 2. Be sure the front locking latch is open, then carefully position the disk drive in the chassis.

Step 3. Slide the disk drive into the chassis; use a slow, firm pressure properly seat the connection.

Step 4. Rotate the front locking latch inward, until the release tab locks into place, to secure the disk drive in the chassis.

Step 5. Spin up the disk by entering either of the following commands:

- `#diskinfo -v /dev/rdisk/cxtxdx`
- `#ioscan -f`

Removing and Replacing a Removable Media Drive

A removable media drive can be a DVD drive or a DDS-4 tape drive located in the front of the chassis (Figure 6-11). You must power off the system before attempting to remove or replace this CRU. Refer to “Powering Off Hardware Components and Powering On the Server” on page 184 and Chapter 4 “Operating System Boot and Shutdown” for more information.

Figure 6-11 Removable Media Drive Location

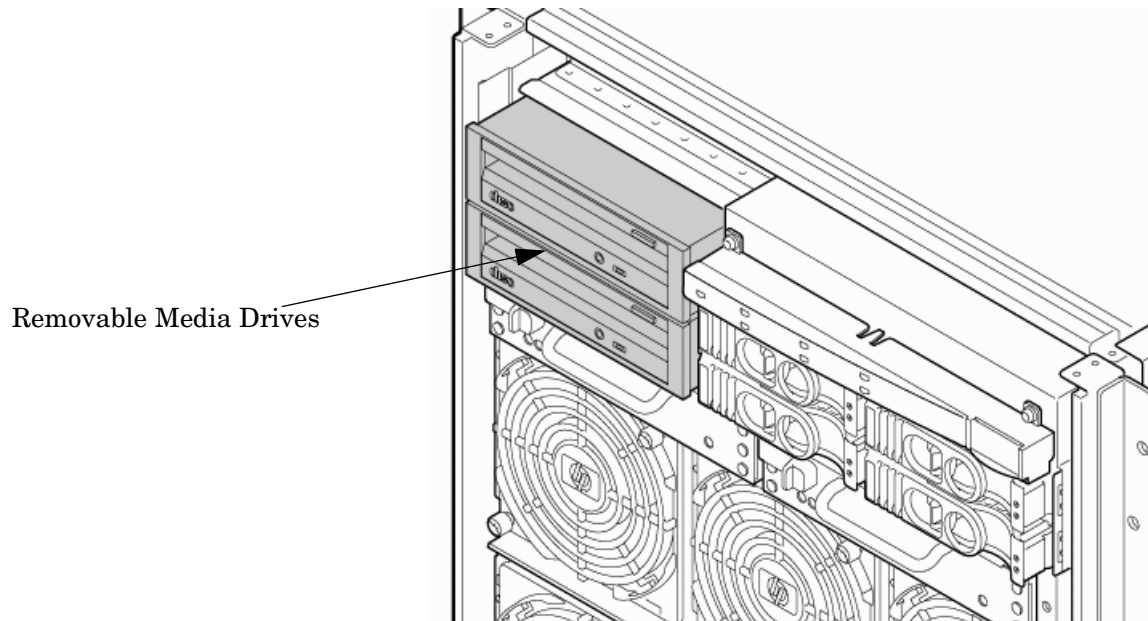

Removing the Removable Media Drive

NOTE When removing the bottom drive, remove the top drive first.

- Step 1.** Identify the failed removable media drive.
- Step 2.** Turn off the power to the server.
- Step 3.** Connect to ground with a wrist strap. Refer to “Electrostatic Discharge” on page 182 for more information.
- Step 4.** Remove the front bezel.
- Step 5.** Push the front locking tab inward to detach the drive from the chassis (Figure 6-12).
- Step 6.** Pull the drive out of the chassis. to expose the rear connectors.
- Step 7.** Unhook the cables from the rear of the drive.
- Step 8.** Slide the drive from the chassis.

Step 9. Remove the rails and clips from the drive.

Figure 6-12 Removable Media Drive Detail

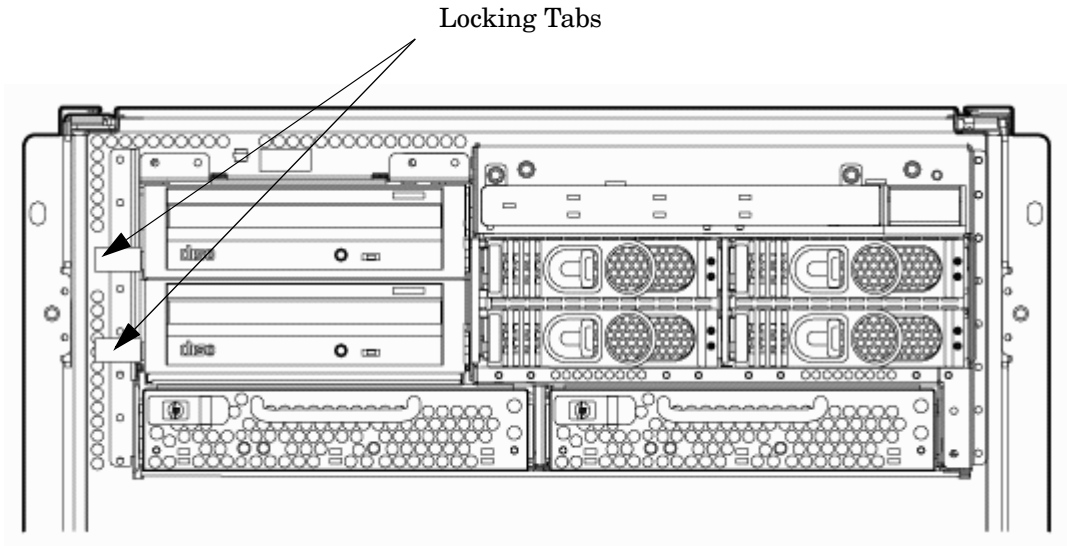

Replacing the Removable Media Drive

NOTE If applicable, install the bottom drive before installing the top drive.

- Step 1.** Attach the rails and clips to the drive.
- Step 2.** Connect the cables to the rear of the drive.
- Step 3.** Position the drive in the chassis.
- Step 4.** Turn the power on to the server.
- Step 5.** Verify operation of the drive. Enter the `SEARch` or `INFO` command at the EFI Shell to ensure that the system recognizes the drive.

Removing and Replacing a PCI Card

The PCI cards are located in the rear of the chassis in the PCI card cage (Figure 6-13). PCI cards are hot-plug components. Refer to “Hot-Plug CRUs” on page 181 for a list and description of hot-plug CRUs.

IMPORTANT Complete information regarding OL* for I/O cards is on the Web at:

<http://docs.hp.com>.

Refer to the *Interface Card OL* Support Guide* for details. It is strongly recommended that you obtain a copy of this document and refer to it before beginning the removal and replacement of PCI cards.

Figure 6-13 PCI Card Location

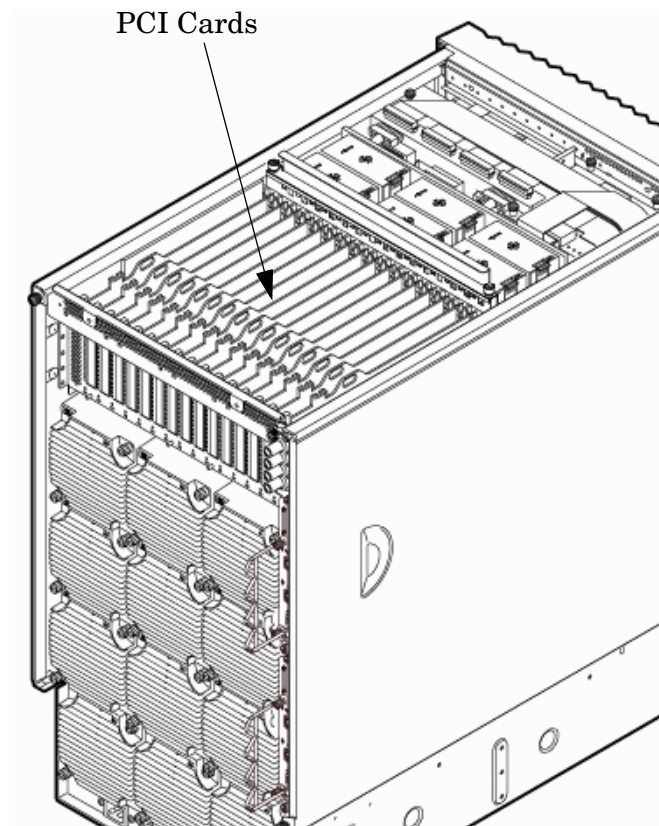

Removing the PCI Card

PCI I/O OL* Card Methods

Following are three methods for performing OL* operations on PCI I/O cards.

- pdweb The Peripheral Device Tool (pdweb) Web-based method of performing OL*.
- olrad The command line method of performing OL*.

Attention button

The hardware system slot-based method of performing OL*.

This procedure describes how to perform an online replacement of a PCI card using the attention button for cards whose drivers support online addition or replacement (OLAR). The attention button is also referred to as the doorbell.

The following are prerequisites for this procedure:

- The replacement card uses the same drivers and is of the same type as the card being installed.
- The green power LED is steady **ON**.
- The yellow attention LED is steady **OFF** or is blinking if a user has requested the slot location.
- Run the `olrad -q` command to determine the status of all the PCI I/O slots.

Step 1. Remove the top cover. Refer to “Removing and Replacing Covers” on page 186 for the procedure.

Step 2. Press the attention button. Refer to Figure 6-14.

The green power LED will start to blink and then turn steady **OFF**. If the green power LED does not go **OFF**, then check the `hotplugd` daemon log file (default: `/var/adm/hotplugd.log`) for errors. Do not proceed further.

NOTE

If the attention button is pressed a second time during the first 5 seconds while the green LED is blinking, the operation is cancelled and power to the slot remains on.

Figure 6-14 PCI I/O Slot Details

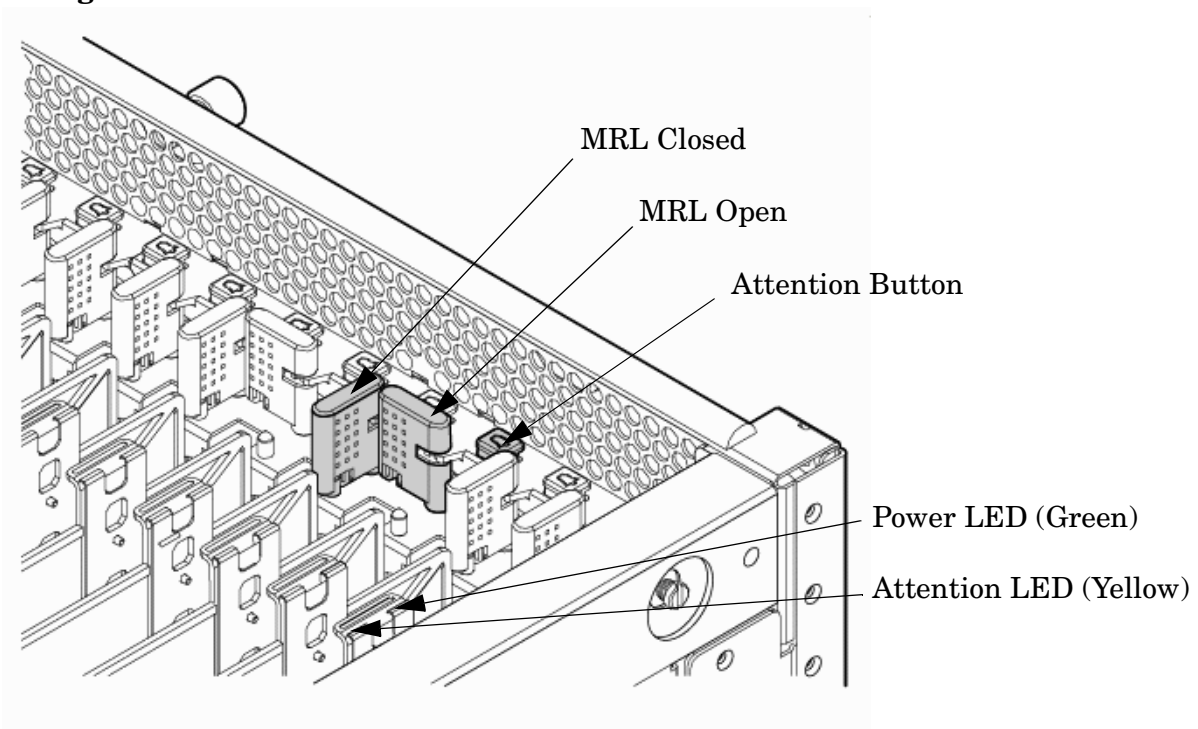

Step 3. Label and remove the cables connected to the PCI card to be removed.

Step 4. Flip the PCI MRL for the card slot to the open position.

Step 5. Firmly pull up on the tabs on the PCI card separator.

Step 6. Remove the card from the PCI slot.

Replacing the PCI Card

Step 1. Install the new replacement PCI card in the slot.

NOTE	Online addition using the attention button does not perform the pre-add sequence of <code>olrad</code> which uses the <code>olrad -a</code> command.
-------------	------------------------------------------------------------------------------------------------------------------------------------------------------

Step 2. Flip the PCI MRL for the card slot to the closed position.

Step 3. Connect all cables to the replacement PCI card.

Step 4. Press the attention button.

The green power LED will start to blink.

Step 5. Wait for the green power LED to stop blinking and turn solid green.

Step 6. Check for errors in the `hotplugd` daemon log file (default: `/var/adm/hotplugd.log`).

Step 7. Replace the top cover. Refer to “Replacing the Top Cover” on page 187.

The critical resource analysis (CRA) performed while during a replace action initiated by the attention button is very restrictive and the action will not complete—it will fail—to protect critical resources from being impacted. For finer control over CRA actions use `pdweb` or the `olrad` command. Refer to the *Interface Card OL* Support Guide* located on the Web at <http://docs.hp.com> for details.

Option ROM

To enable faster booting, system firmware does not auto-scan PCI devices with an Option ROM. In order to enable booting from a PCI connected device with an Option ROM, you must add this device to the table of boot devices as follows:

Step 1. Install the I/O card into the chassis.

Step 2. Boot the server to the EFI Shell.

Step 3. Execute the EFI search command.

To add a single card:

```
#search cell pci_slot#
```

To add all cards:

```
search all
```

Step 4. Execute the following EFI command to scan devices on the server:

```
map -r
```

Step 5. Enter the Boot Manager by executing the following command:

```
#exit
```

Step 6. From the EFI Boot Manager Menu, select Boot Option Maintenance Menu and then from the Main Menu, select Add a Boot Option. Now add the device as a new boot device.

Updating Option ROMs

The Option ROM on a PCI I/O card can be “flashed,” or updated. The procedure to flash an I/O card follows.

Step 1. Install the I/O card into the chassis.

Step 2. Boot the server to the EFI Shell.

Step 3. Execute the EFI search command.

To add a single card:

```
search cell pci_slot #
```

To add all cards:

```
search all
```

Step 4. Execute the following EFI command:

```
map -r
```

NOTE Each I/O card type and firmware image update may require a different flash utility and procedure. Follow the instructions in the `.txt` file included with the latest HP IPF Offline Diagnostic & Utilities CD.

Step 5. Load the HP IPF Offline Diagnostic & Utilities CD.

The CD will contain the flash utility for IO each card type, firmware images, and a `.txt` file that will include instructions and information about updating the firmware images.

Removing and Replacing a PCI Smart Fan Assembly

The PCI smart fan assembly is located in front of the PCI card cage (Figure 6-15). The fan assembly is a hot-swap component. Refer to “Hot-Swap CRUs” on page 181 for a list and description of hot-swap CRUs.

Figure 6-15 PCI Smart Fan Assembly Location

Top View

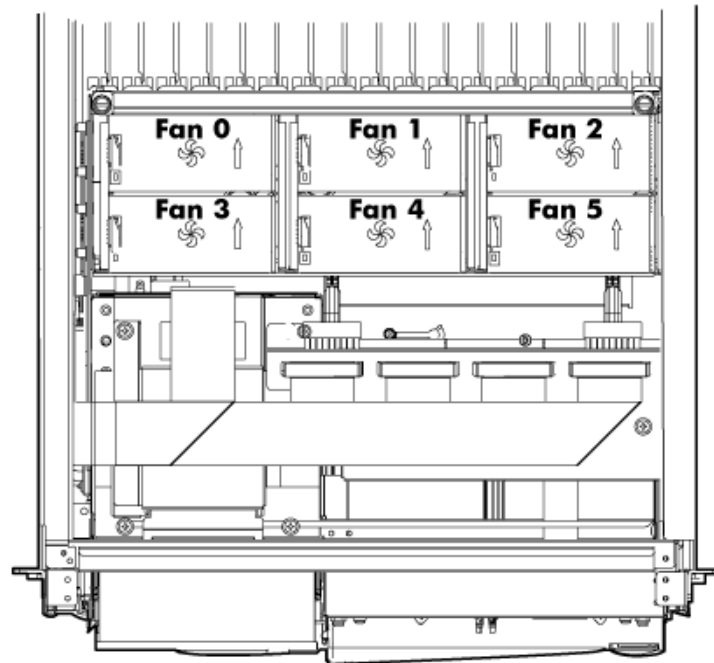

Front of Server

Preliminary Procedures

Complete these procedures before removing the PCI smart fan assembly.

Step 1. Connect to ground with a wrist strap. Refer to “Electrostatic Discharge” on page 182 for more information.

Step 2. Remove the top cover. See “Removing and Replacing Covers” on page 186.

Step 3. Identify the failed fan assembly. Table 6-2 defines the fan LED states.

Table 6-2 Smart Fan Assembly LED Indications

LED State	Meaning
Green	Fan is at speed and in sync or not at speed less than 12 seconds.
Flash Yellow	Fan is not keeping up with speed/sync pulse for longer than 12 seconds.

Table 6-2 Smart Fan Assembly LED Indications (Continued)

LED State	Meaning
Red	Fan failed, stalled or has run slow or fast for longer than 12 seconds.
Off	Fan is not present, no power is applied to fan, or the fan has failed.

Removing the PCI Smart Fan Assembly

- Step 1.** Securely grasp the two tabs on the fan assembly (Figure 6-16).
- Step 2.** Slide the fan upward from the chassis.

Figure 6-16 PCI Smart Fan Assembly Detail

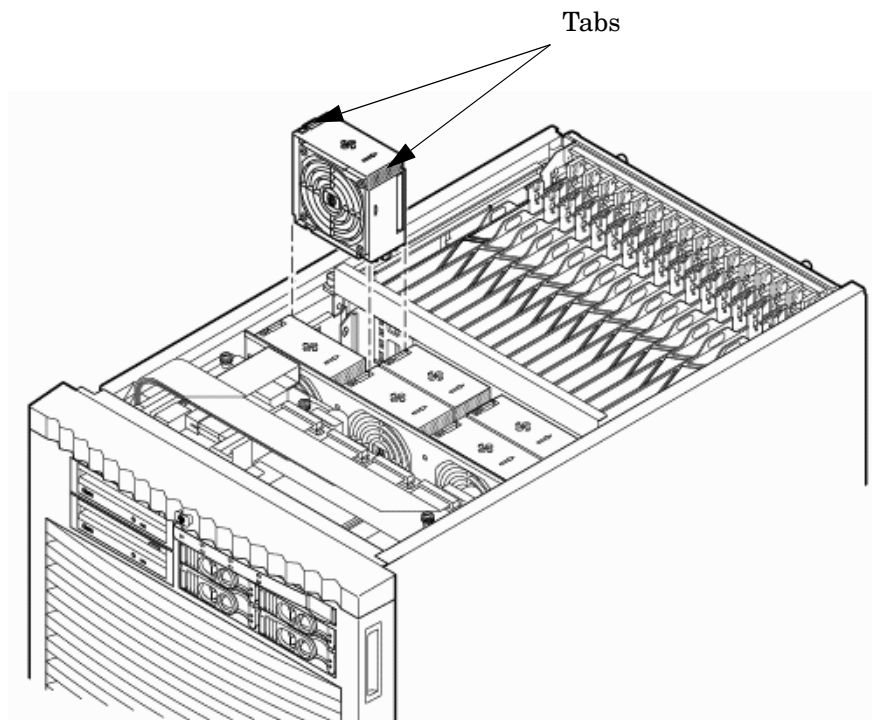

Replacing the PCI Smart Fan Assembly

- Step 1.** Position the fan assembly in the chassis.
- Step 2.** The fan easily slides into the chassis; apply a slow, firm pressure to properly seat the connection.

The fan status LED should be GREEN.

- Step 3.** Replace the top cover. Refer to “Removing and Replacing Covers” on page 186.

Removing and Replacing a PCI Power Supply

The PCI-X power supply is located in the front of the chassis. See Figure 6-17. The power subsystem has N+1 redundancy when both power supplies are installed. It is not necessary to power down the PCI domain to replace a failed PCI power supply.

Figure 6-17 PCI Power Supply Location

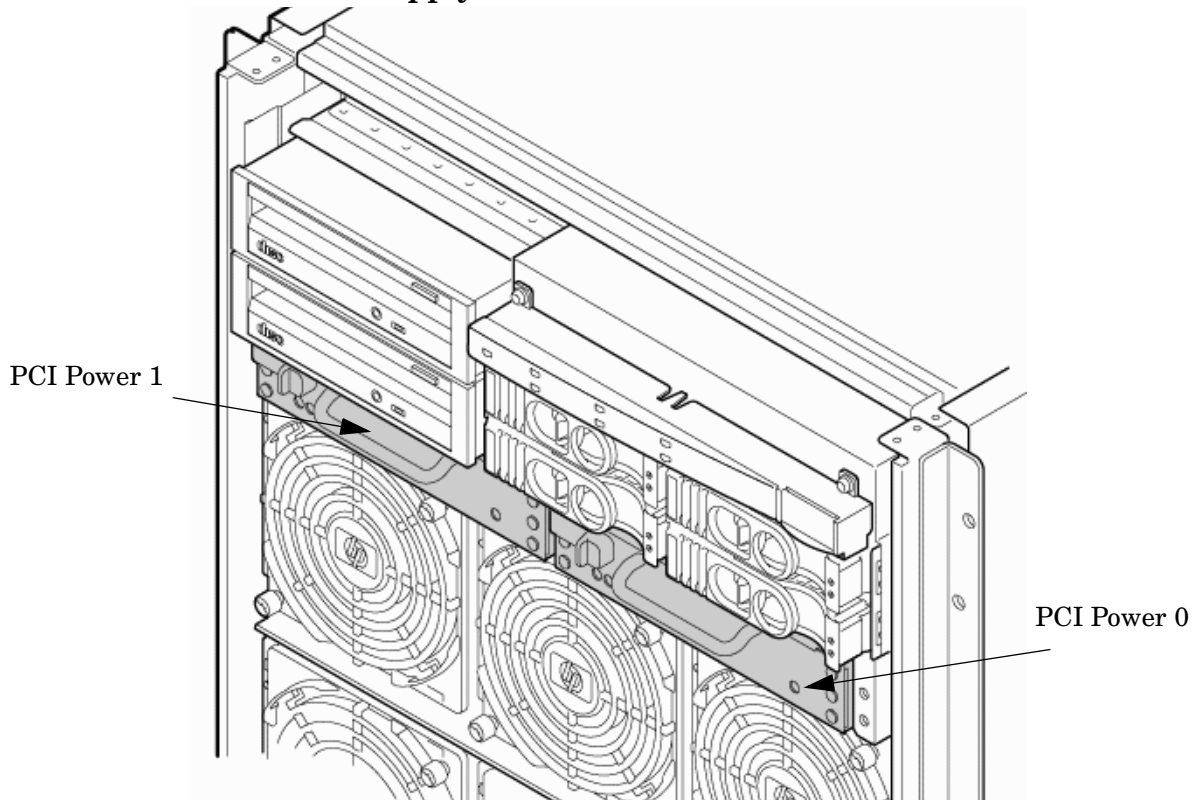

Preliminary Procedures

Complete these procedures before removing the PCI power supply.

- Step 1.** Connect to ground with a wrist strap. Refer to “Electrostatic Discharge” on page 182 for more information.
- Step 2.** Remove the front bezel. Refer to “Removing and Replacing the Front Bezel” on page 189.
- Step 3.** Identify the failed power supply. Table 6-3 identifies the meaning of the PCI power supply LED state.
- Step 4.** Visually inspect the replacement part for proper part number and revision.

Table 6-3 PCI-X Power Supply LEDs

LED	Driven By	State	Description
Power	Each supply	Green	All output voltages generated by the power supply are within limits.
		Off	Power to entire system has been removed.
Fault	Each supply	Flash Yellow	The temperature within the power supply is above the lower threshold.
		On Yellow	The temperature of the power supply is approaching the thermal limit.
		Flash Red	Power supply has shut down due to an over temperature condition, a failure to regulate the power within expected limits, or a current-limit condition.
		Off	Normal operation.

Removing the PCI Power Supply

- Step 1.** Securely grasp the handle on the front of the power supply.
- Step 2.** Firmly depress the securing thumb latch.

Step 3. Slide the module from the chassis. Refer to Figure 6-18.

Figure 6-18 PCI Power Supply Detail

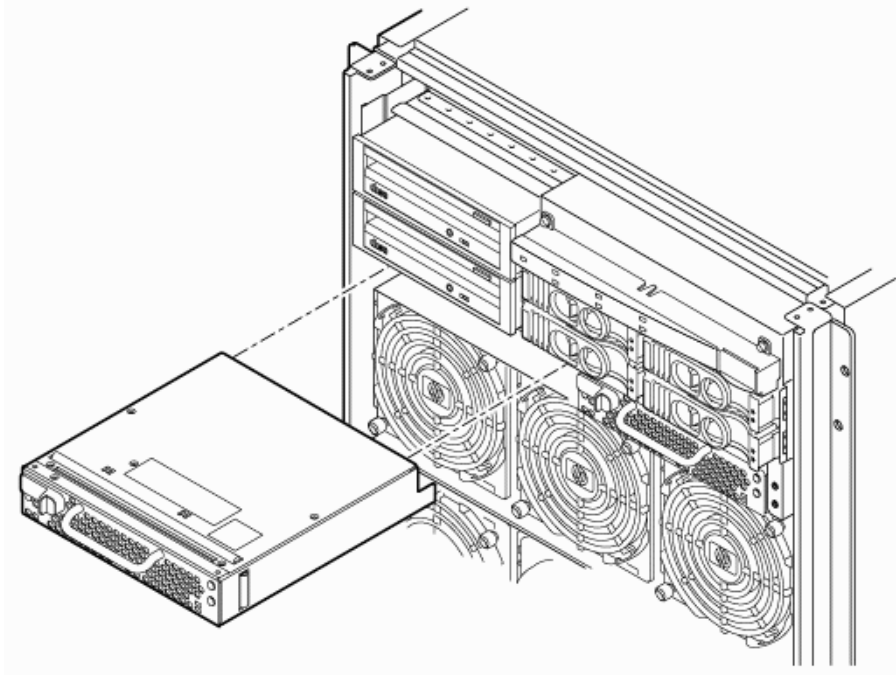

Replacing the PCI Power Supply

Step 1. Slide the power supply in the chassis until the thumb latch clicks into the locked position.

Step 2. The module easily slides into the chassis; apply a slow, firm pressure to properly seat the connection.

Step 3. Verify the status of the power supply LEDs. Green LED should be **ON** and the fault LED should be **OFF**.

Removing and Replacing a Bulk Power Supply (BPS)

The bulk power supply (BPS) is located in the front of the chassis (Figure 6-19). The BPS is a hot-swap component. Refer to “Hot-Swap CRUs” on page 181 for a list and description of hot-swap CRUs.

Cell Board Power Requirements

The number of cell boards installed will determine the minimum number of bulk power supplies (BPS) required to support them.

A minimum of two BPS are required to support a single cell board installed in the server. This is not a N+1 configuration. See Table 6-4 for N+1 configurations of multiple cell boards.

The server can accommodate a total of six BPSs. N+1 capability provides one additional bulk power supply to fail over to. If one BPS fails, adequate power is supplied to the cell boards to keep the server partitions operational. Replace the failed BPS promptly to restore N+1 functionality.

Table 6-4 N+1 BPS-to-Cell Board Configuration

Number of Cell Boards Installed in the Server	Number of Operational BPS Installed to Maintain N+1 Functionality
1	3
2	4
3	5
4	6

The power distribution for the bulk power supplies follows:

- A0 input provides power to BPS 0, BPS 1, and BPS 2
- A1 input provides power to BPS 3, BPS 4, and BPS 5
- B0 input provides power to BPS 0, BPS 1, and BPS 2

- B1 input provides power to BPS 3, BPS 4, and BPS 5

Figure 6-19 BPS Location (Front Bezel Removed)

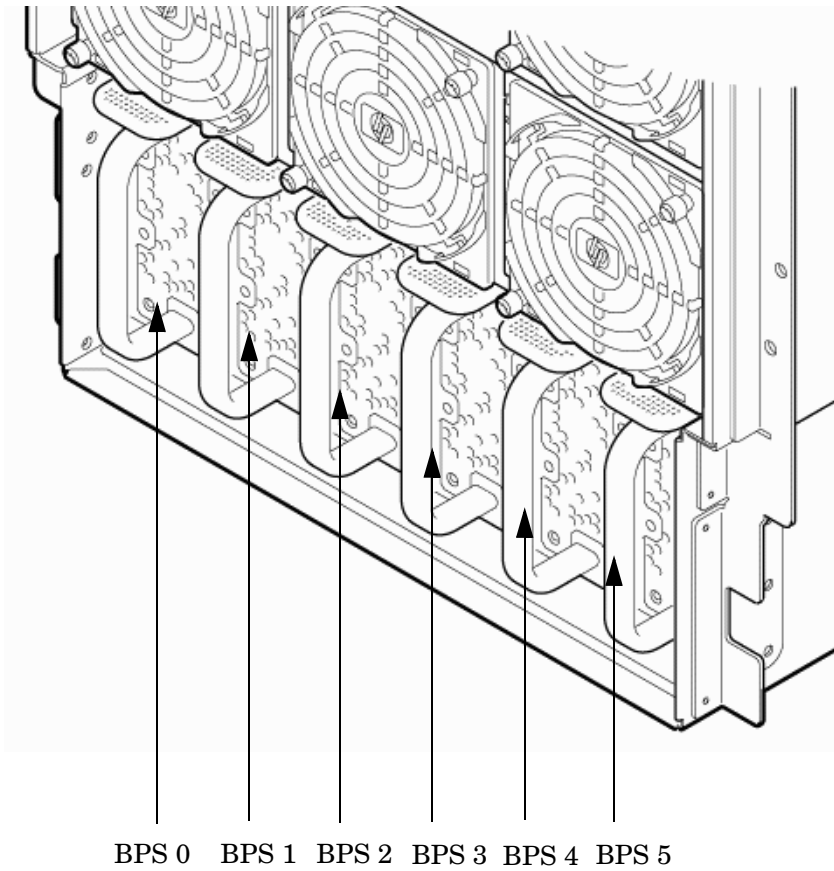

Removing the BPS

Step 1. Remove the front bezel.

Step 2. Isolate the failing BPS. Table 6-5 defines the states of the single multicolored LED on the BPS.

Table 6-5 BPS LED Definitions

LED State	Description
Blink Green	BPS in standby state and no faults or warnings are present.
Green	BPS in run state (48 volt output enabled) and no faults or warnings are present.
Blink Yellow	BPS in standby or run state and warnings are present but no faults.
Yellow	BPS in standby state, and recoverable faults are present but no non-recoverable faults.
Blink RED	BPS state may be unknown, nonrecoverable faults are present.
Red	This LED state is not used.
Off	BPS fault or failure (unless AC power is not connected to server).

Step 3. Depress the release latch on the upper front center portion of the BPS. See Figure 6-20 on page 210.

Step 4. Slide the BPS forward using the handle to remove it from the chassis.

Figure 6-20 BPS Detail

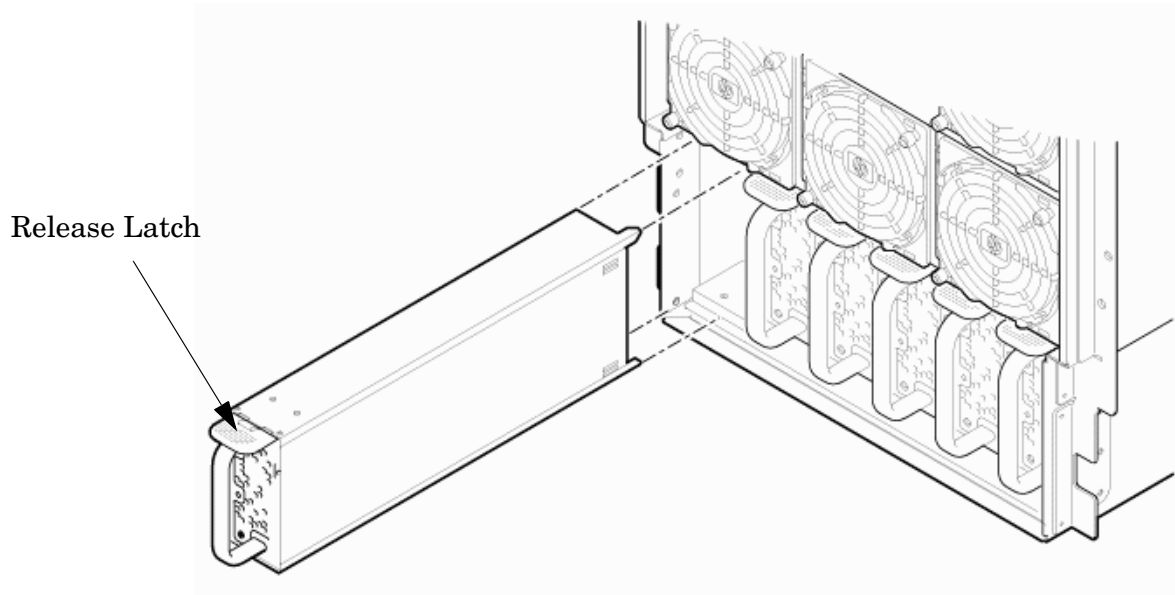

Replacing the BPS

Step 1. Grip the handle with one hand while supporting the rear of the BPS in the other hand.

NOTE The BPS easily slides into the chassis; apply a slow, firm pressure to properly seat the connection.

Step 2. Slide the power supply into the slot until it is fully seated.

When seated, the release latch will click and lock into place.

Step 3. Note status of the BPS LED. The LED should be green.

NOTE When a BPS fails and is replaced on line, the PS command will sometimes display the cached status data of the BPS. Use the `CM>DE` command to verify the actual state of the BPS.

Step 4. Replace the front bezel.

A Replaceable Parts

This appendix contains the server CRU list. For a more updated list of part numbers, go to the HP Part Surfer web site at:

<http://www.partsurfer.hp.com>

Replaceable Parts List

Table A-1 Server CRU Descriptions and Part Numbers

CRU DESCRIPTION	Replacement P/N	Exchange P/N
POWER CORDS AND CABLES		
Jumper UPS-PDU 2.5m C19/C20	8120-6884	None
Pwr Crd, C19/unterminated intl-Europe	8120-6895	None
Pwr Crd, C19/IEC-309 L6-20 4.5 m BLACK CA Ay	8120-6897	None
Pwr Crd, C19/L6-20 4.5 m BLACK C	8120-6903	None
Pwr Crd, Jumper UPS-PDU 4.5 m C19/C20	8120-6961	None
Pwr Crd, C19/GB 1002 4.5m Black CA Ay	8121-0070	None
MASS STORAGE DEVICES		
36 GB ultra 320 15K RPM SCSI Disk	AB420-2101A	AB420-69001
73 GB Ultra 320 15K RPM SCSI Disk	AB421-2101A	AB421-69001
146 GB ultra 320 10K RPM SCSI Disk	AB422-2101A	AB422-69001
300 GB ultra 320 10K RPM SCSI Disk	AB423-2101A	AB423-69001
Removable DAT 72Gb (DDS4)	DW009-67201	DW009-69201
DVD +RW Drive	AB351-67002	None
FANS		
Assy. Smart Fan Front	A6093-67017	None
Assy, Smart Fan Rear	A6093-67018	None
Assy, Smart Fan PCI C/C	A6752-67030	None
POWER		
PCI-X N+1 Power Module	0950-4637	None
AC Power Supply (BPS)	0950-3794	A6093-69021
OTHER COMPONENTS		
Nameplate, rx8640	AB297-2111A	None
Nameplate, rp8440	A9958-3401A	None
Filler, Internal Disk (Carbon)	A6198-60003	None
Box, DVD Filler (Carbon)	A6912-00014	None
Assy, Bezel, No NamePlate (Graphite)	A6912-04009	None

Table A-1 Server CRU Descriptions and Part Numbers (Continued)

CRU DESCRIPTION	Replacement P/N	Exchange P/N
Snap, Bezel Attach	C2786-40002	None
KITS		
Removable Media Rail Kit	A6752-67011	None

B MP Commands

This appendix contains a list of the server management commands.

Server Management Commands

Table B-1 lists the server management commands.

Table B-1 Management Commands

Command	Description
BO	Boot a partition
DF	Display FRU Information of an Entity
MA	Return to Main Menu
OSP	Obsolete
PE	Power entities on or off
RE	Reset entity
RR	Reset partition for reconfiguration
RS	Reset a partition
SYSREV	Returns all System Revisions
TC	Send a TOC signal to a partition
TE	Broadcast a message to all users of the MP command handler
WHO	Display list of MP connected users
LOC	Display and Set Locator LED status

Table B-2 lists the server status commands

Table B-2 Status Commands

Command	Description
CP	Display partition cell assignments
HE	Display the list of available commands
LS	Display LAN connected console status
PS	Display detailed power and hardware configuration status

Table B-3 lists the server system and access configuration commands

Table B-3 System and Access Configuration Commands

Command	Description
CC	Initiate a Complex Configuration
CG	Generate ssl key pair and self signed certificate

Table B-3 System and Access Configuration Commands (Continued)

CP	Display partition cell assignments
DATE	Set the time and date
DC	Reset parameters to default configuration
DE	Display entity status
DI	Disconnect Remote or LAN console
DFW	Duplicate firmware
DU	Display devices on bus
FW	Obsolete. FW is now available at the MP Main Menu.
ID	Change certain stable complex configuration profile fields
IF	Display network interface information
IT	Modify command interface inactivity timeout
LC	Configure LAN connections
LS	Display LAN connected console status
PD	Modify default Partition for this login session
PWRGRD	Allows user to configure the power grid
PARPERM	Enable/Disable interpartition security
RL	Re-key complex profile lock
RU	Reset MP bus device
SA	Display and set MP remote access
SO	Configure security options and access control
UPS	Set parameters for ups monitoring via snmp
SNMP	Set SNMP daemon parameters
XD	MP Diagnostic and reboot

C Templates

This appendix contains blank floor plan grids and equipment templates. Combine the necessary number of floor plan grid sheets to create a scaled version of the computer room floor plan.

Figure C-1 illustrates the overall dimensions required for the servers.

Figure C-1 Server Space Requirements

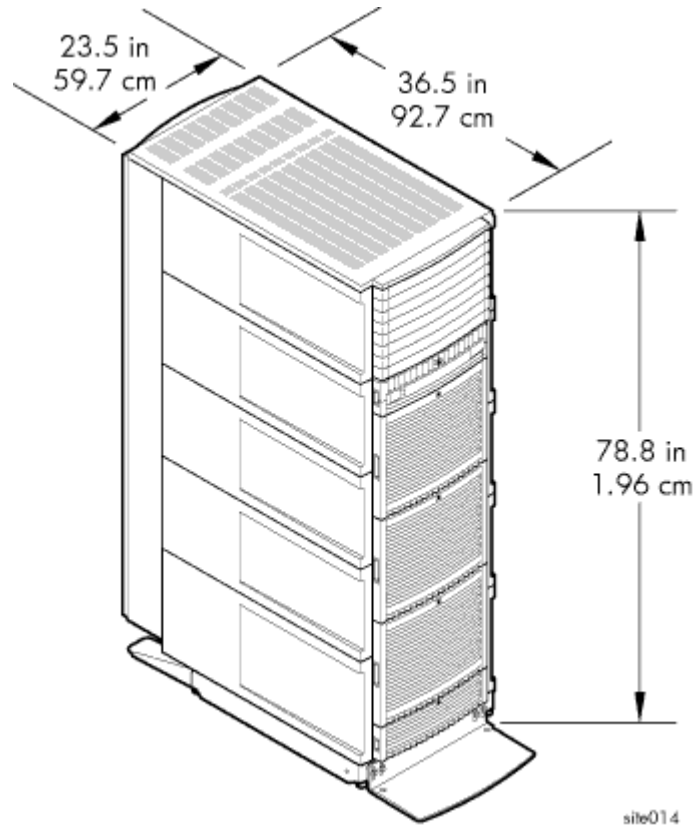

Equipment Footprint Templates

Equipment footprint templates are drawn to the same scale as the floor plan grid (1/4 inch = 1 foot). These templates show basic equipment dimensions and space requirements for servicing. Refer to Figure C-2 on page 223.

The service areas shown on the template drawings are lightly shaded.

Use the equipment templates with the floor plan grid to define the location of the equipment that will be installed in your computer room.

NOTE Photocopying typically changes the scale of drawings copied. If you copy any templates, then you must also copy all templates and floor plan grids.

Computer Room Layout Plan

Use the following procedure to create a computer room layout plan:

- Step 1.** Remove several copies of the floor plan grid (Figure C-3).
- Step 2.** Cut and join them together (as necessary) to create a scale model floor plan of your computer room.
- Step 3.** Remove a copy of each applicable equipment footprint template (Figure C-2).
- Step 4.** Cut out each template selected in step 3; then place it on the floor plan grid created in step 2.
- Step 5.** Position pieces until you obtain the desired layout, then fasten the pieces to the grid. Mark locations of computer room doors, air-conditioning floor vents, utility outlets, and so on.

NOTE Attach a reduced copy of the completed floor plan to the site survey. HP installation specialists use this floor plan during equipment installation.

Figure C-2 Server Cabinet Template

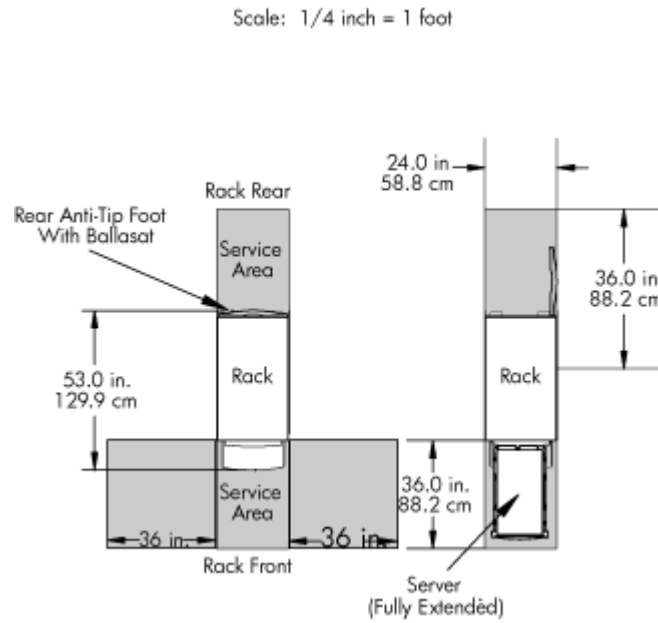

Figure C-3 Planning Grid

Scale: 1/4 inch = 1 foot

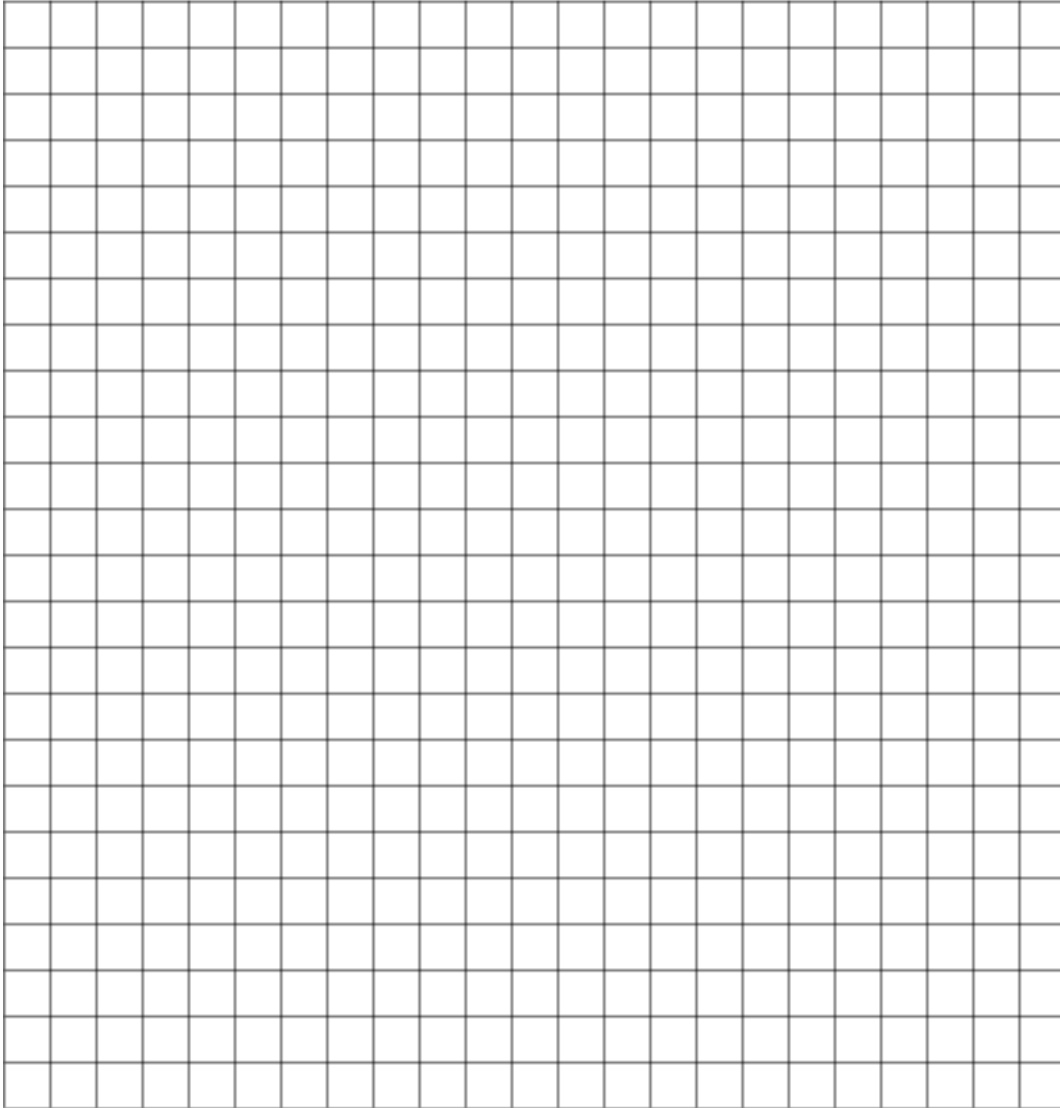
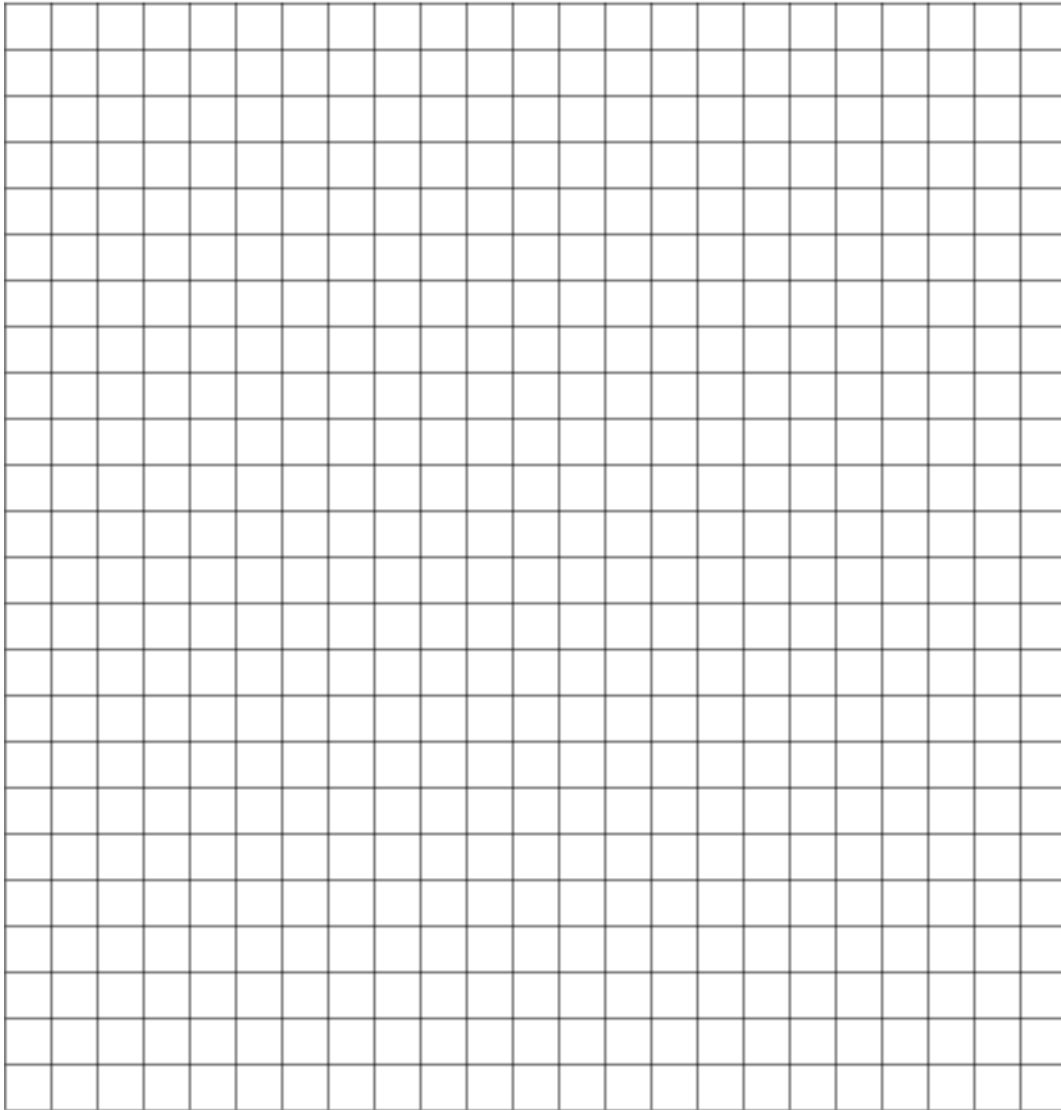

Figure C-4 Planning Grid

Scale: 1/4 inch = 1 foot



A

- ac power
 - input, 98
 - voltage check, 97
- AC power inputs
 - A0, 98
 - A1, 98
 - B0, 98
 - B1, 98
- AC power specifications, 45
- access
 - commands, 217
- administrator, 175
- air ducts, 54
 - illustrated, 54
- AR, 217
- ASIC, 21

B

- backplane
 - mass storage, 41, 43
 - system, 39, 41, 43, 51
- BO, 217
- BPS (Bulk Power Supply), 106
- Bulk Power Supplies
 - BPS, 99, 207

C

- CA, 217
- cable, 157
- cards
 - core I/O, 171
- CC, 217
- cell board, 38, 43, 51, 100, 113, 164, 207
 - verifying presence, 112
- cell controller, 21
- chassis
 - login, 172
 - management, 172
- checklist
 - installation, 116
- circuit breaker, 45
- cm (Command Menu) command, 112
- co (Console) command, 114
- command, 217
 - cm (Command Menu), 112
 - co (Console), 114
 - CTRL-B, 114
 - di (Display), 115
 - du (display MP bus topology), 112
 - lc (LAN configuration), 109
 - ls (LAN status), 109
 - PE, 185
 - pwrgrd (Power Grid), 113
 - scsi default, 185
 - ser, 185
 - T, 185
 - vfp (Virtual Front Panel), 113
- communications interference, 182
- component

- power requirements, 46
- computer room layout plan, 222
- computer system
 - air ducts, 54
- configuration, 171
- console, 171
 - redirection, 172
- controls, 26
- cooling, 51
- core I/O, 21, 41
- core I/O card, 171
- CP, 217

D

- DAT, 21
- DATE, 217
- DC, 217
- DF, 217
- DI, 217
- di (Display) command, 115
- dimensions and weights, 43
- DIMMs, 29
 - memory, 29
- disk
 - internal, 41, 79, 103
- disk drive, 21
- DL, 217
- du (display MP bus topology) command, 112
- DVD/CD, 21

E

- EL, 217
- electrical specifications, 45
- electrostatic discharge, 182
- environmental considerations, 182
- environmental specifications, 49
- equipment footprint templates, 221
- ER, 217
- error, 157
- error message, 176
- ESD precautions
 - ESD kit, part number, 183

F

- facility guidelines
 - computer room layout, 222
 - equipment footprint templates, 221
- fan
 - control, 173
- fans, 21
- fault, 158
- field replaceable unit (FRU)
 - FRU, 181
- firmware, 175
- firmware update, 176
- flash memory, 175
- front panel, 26
- FW, 217

G

- gateway address, 109

Index

getty, 171
grounding, 45

H

HE, 217
high availability (HA), 171
hot-plug
 defined, 181
hot-swap
 defined, 181
housekeeping power, 105
HP-UX, 171
humidity, 49

I

I/O bay, 173
I/O Subsystem, 37, 38
iCOD
 definition, 116
 email requirements, 116
ID, 217
IF, 217
initial observations
 interval one, 100
 interval three, 100
 interval two, 100
inspecting for damage, 57
installation
 checklist, 116
 warranty, 57
installation problems, 157
interference, 182
IP address
 default, 108
 lc Comand Screen, 109
IT, 217

L

LAN, 171, 175
LAN status, 109
LC, 217
lc (LAN configuration) command, 109
LED, 158
 Attention, 106
 Bulk Power Supply, 106
 management processor, 26
 MP Present, 106
 remote port, 26
 Standby Power, 106
 traffic light, 26
login name
 MP, 107
LS, 217
ls (LAN Status) command, 109

M

MA, 217
MAC address, 109
management hardware, 171
management LAN, 175

Management Processor (MP), 103
management processor (MP), 171
 failure, 171
mass storage backplane, 41, 43
memory, 21
 subsystem, 28
monitoring, 173
MP
 login name, 107
 password, 107
MP (Management Processor)
 logging in, 105
 powering on, 105
MP core I/O, 34, 79
MP network name, 109
MP/SCSI, 103
MR, 217
MS, 217

N

N+1, 21
N+1 capability, 100, 207
ND, 217
no power, 157
noise emission specifications, 53
null modem cable
 connectivity, 104
 part number, 104

O

operating environment, 49
OTH, 173
OTL, 173
OTM, 173
overtemp, 173

P

password
 MP, 107
PCI, 21
PD, 217
PDC
 Processor Dependent Code, 114
PE, 217
Platform Dependent Code (PDC), 171
POST, 158
power, 185
 applying cabinet, 113
 cabinet switch, 114
 control, 173
 housekeeping, 105, 113
 plugs, 21
 problems, 157
 requirement, 21
 sources, 98
power cords, 45
power requirements
 component, 46
power supplies, 21
processor
 service, 21

Processor Dependent Code
 PDC, 114
processors, 21
PS, 217
PWRGRD, 217
pwrgrd (Power Grid) command, 113

R

rank, 31
RE, 217
Reflection 1, 104, 113
RL, 217
RR, 217
RS, 217
RS-232, 171
RU, 217

S

safety considerations, 182
serial display device
 connecting, 103, 104
 recommended windows, 113
 setting parameters, 103
server, 171
 block diagram, 22
 computer room layout, 222
 configuration, 171
 front panel, 26
 management, 171
 management commands, 217
 management overview, 172
 status commands, 217
service access, 172
service processor, 21, 171
session redirection, 172
SO, 217
space requirements
 computer room layout, 222
 equipment footprint templates, 221
Standby power LED, 26
status LEDs, 26
subnet mask, 109
SYSREV, 217
system
 commands, 217
 configuration, 171
 power on, 185
system backplane, 39, 41, 43, 51
system configuration, verifying, 115

T

TC, 217
TE, 217
temperature, 49, 173
 states, 173
troubleshooting, 157
 fault LED, 158
 self test, 158
turbocoolers, 21

U

unpacking
 inspecting for damage, 57
update firmware, 175, 176

V

verifying system configuration, 115
voltage check, 97

W

warranty, 57
web console, 171
WHO, 217
wrist strap, 183

X

XD, 217